

BS EN ISO 3690:2012



BSI Standards Publication

Welding and allied processes — Determination of hydrogen content in arc weld metal (ISO 3690:2012)

bsi.

...making excellence a habit.™

National foreword

This British Standard is the UK implementation of EN ISO 3690:2012. It supersedes BS EN ISO 3690:2001 which is withdrawn.

The UK participation in its preparation was entrusted to Technical Committee WEE/39, Welding consumables.

A list of organizations represented on this committee can be obtained on request to its secretary.

This publication does not purport to include all the necessary provisions of a contract. Users are responsible for its correct application.

© The British Standards Institution 2012. Published by BSI Standards Limited 2012

ISBN 978 0 580 59123 5

ICS 25.160.40; 77.080.20

Compliance with a British Standard cannot confer immunity from legal obligations.

This British Standard was published under the authority of the Standards Policy and Strategy Committee on 30 April 2012.

Amendments issued since publication

Date	Text affected
------	---------------

English Version

Welding and allied processes - Determination of hydrogen content in arc weld metal (ISO 3690:2012)

Soudage et techniques connexes - Détermination de la teneur en hydrogène dans le métal fondu pour le soudage à l'arc (ISO 3690:2012)

Schweißen und verwandte Prozesse - Bestimmen des Wasserstoffgehaltes im Lichtbogenschweißgut (ISO 3690:2012)

This European Standard was approved by CEN on 2 March 2012.

CEN members are bound to comply with the CEN/CENELEC Internal Regulations which stipulate the conditions for giving this European Standard the status of a national standard without any alteration. Up-to-date lists and bibliographical references concerning such national standards may be obtained on application to the CEN-CENELEC Management Centre or to any CEN member.

This European Standard exists in three official versions (English, French, German). A version in any other language made by translation under the responsibility of a CEN member into its own language and notified to the CEN-CENELEC Management Centre has the same status as the official versions.

CEN members are the national standards bodies of Austria, Belgium, Bulgaria, Croatia, Cyprus, Czech Republic, Denmark, Estonia, Finland, France, Germany, Greece, Hungary, Iceland, Ireland, Italy, Latvia, Lithuania, Luxembourg, Malta, Netherlands, Norway, Poland, Portugal, Romania, Slovakia, Slovenia, Spain, Sweden, Switzerland, Turkey and United Kingdom.



EUROPEAN COMMITTEE FOR STANDARDIZATION
COMITÉ EUROPÉEN DE NORMALISATION
EUROPÄISCHES KOMITEE FÜR NORMUNG

Management Centre: Avenue Marnix 17, B-1000 Brussels

Foreword

This document (EN ISO 3690:2012) has been prepared by IIW “International Institute of Welding” in collaboration with Technical Committee CEN/TC 121 “Welding” the secretariat of which is held by DIN.

This European Standard shall be given the status of a national standard, either by publication of an identical text or by endorsement, at the latest by September 2012, and conflicting national standards shall be withdrawn at the latest by September 2012.

Attention is drawn to the possibility that some of the elements of this document may be the subject of patent rights. CEN [and/or CENELEC] shall not be held responsible for identifying any or all such patent rights.

This document supersedes EN ISO 3690:2000.

According to the CEN/CENELEC Internal Regulations, the national standards organizations of the following countries are bound to implement this European Standard: Austria, Belgium, Bulgaria, Croatia, Cyprus, Czech Republic, Denmark, Estonia, Finland, France, Germany, Greece, Hungary, Iceland, Ireland, Italy, Latvia, Lithuania, Luxembourg, Malta, Netherlands, Norway, Poland, Portugal, Romania, Slovakia, Slovenia, Spain, Sweden, Switzerland, Turkey and the United Kingdom.

Endorsement notice

The text of ISO 3690:2012 has been approved by CEN as a EN ISO 3690:2012 without any modification.

Contents

Page

Foreword	iv
1 Scope	1
2 Normative references	1
3 Principle	1
4 Test procedures	2
4.1 Production of weld specimens	2
4.2 Welding procedures for the production of weld specimens	5
4.3 Measurement of hydrogen in the test weld	13
4.4 Measurement of total hydrogen content in the weld metal — Rapid methods	19
4.5 Rounding procedure	19
Annex A (informative) Recommendations and restrictions in regard to older methods of measurement using mercury	20
Annex B (informative) Recommendations and restrictions in regard to older methods of measurement using glycerin	21
Annex C (informative) Accuracy and reproducibility	22
Bibliography	23

Foreword

ISO (the International Organization for Standardization) is a worldwide federation of national standards bodies (ISO member bodies). The work of preparing International Standards is normally carried out through ISO technical committees. Each member body interested in a subject for which a technical committee has been established has the right to be represented on that committee. International organizations, governmental and non-governmental, in liaison with ISO, also take part in the work. ISO collaborates closely with the International Electrotechnical Commission (IEC) on all matters of electrotechnical standardization.

International Standards are drafted in accordance with the rules given in the ISO/IEC Directives, Part 2.

The main task of technical committees is to prepare International Standards. Draft International Standards adopted by the technical committees are circulated to the member bodies for voting. Publication as an International Standard requires approval by at least 75 % of the member bodies casting a vote.

Attention is drawn to the possibility that some of the elements of this document may be the subject of patent rights. ISO shall not be held responsible for identifying any or all such patent rights.

ISO 3690 was prepared by International Institute of Welding, Commission II, *Arc welding and filler metals*, recognized as an international standardizing body in the field of welding in accordance with Council Resolution 42/1999, in collaboration with Technical Committee ISO/TC 44, *Welding and allied processes*, Subcommittee SC 3, *Welding consumables*.

This third edition cancels and replaces the second edition (ISO 3690:2000), which has been technically revised.

Requests for official interpretations of any aspect of this International Standard should be directed to the ISO Central Secretariat, who will forward them to the IIW Secretariat for an official response.

Welding and allied processes — Determination of hydrogen content in arc weld metal

1 Scope

This International Standard specifies the sampling and analytical procedure for the determination of diffusible hydrogen in martensitic, bainitic, and ferritic steel weld metal arising from the welding of such steels using arc welding processes with filler metal.

The techniques specified in this International Standard include collection of diffusible hydrogen via displacement of mercury or collection into a headspace filled with an inert gas such as argon. The amount of hydrogen collected is determined by measuring the displaced volume in the former and by, for example, thermal conductivity in the latter.

The temperature for collection of diffusible hydrogen is controlled to avoid thermal activation of non-diffusible hydrogen.

2 Normative references

The following referenced documents are indispensable for the application of this document. For dated references, only the edition cited applies. For undated references, the latest edition of the referenced document (including any amendments) applies.

ISO 14175, *Welding consumables — Gases and gas mixtures for fusion welding and allied processes*

ISO/TR 17671-1, *Welding — Recommendations for welding of metallic materials — Part 1: General guidance for arc welding*

ISO 80000-1, *Quantities and units — Part 1: General*

3 Principle

Filler material is deposited on to a standard test coupon in a manner that ensures control of pertinent variables to produce a representative specimen for analysis. Subsequent storage and handling of the specimen is controlled to prevent premature loss of hydrogen. Finally, the specimen is transferred to a gas collection apparatus (mercury method) or to a suitable vessel filled with an inert gas (thermal conductivity method) and held for a period of time at a temperature sufficient to quantitatively release the diffusible hydrogen into an evacuated gas burette or into the inert gas headspace, respectively. The amount of hydrogen collected is determined by measuring the displaced volume (mercury method) or by thermal conductivity. Finally, quantification of the mass of deposited metal or volume of fused weld metal enables calculations of diffusible hydrogen in deposited metal, H_D , or diffusible hydrogen in fused weld metal, H_F , to be made.

4 Test procedures

4.1 Production of weld specimens

4.1.1 Summary

The welding consumable to be tested is used to deposit a single weld bead, which is rapidly quenched and subsequently stored at $-78\text{ }^{\circ}\text{C}$ or lower until analysis. Cleaning and slag removal are performed on the chilled specimen.

4.1.2 Welding fixture

An example of a suitable welding fixture to provide uniform test pieces for the welding processes specified in 4.2 is shown in Figure 1. It is designed to hold the uniform test pieces securely in alignment during welding and, in particular, to ensure that unclamping upon completion of welding can be carried out in a single operation according to the conditions specified in 4.1.4 c). The surface temperature of the fixture shall be between ambient and $25\text{ }^{\circ}\text{C}$ above ambient at the start of each test weld. The fixture may be water cooled to decrease the cycle time. The temperature of the cooling water shall be controlled to prevent condensation of water on the surface of the fixture between test welds.

For all welding processes, the test piece assembly is clamped in the welding fixture using annealed copper foil as shown in Figure 1. The foil may be annealed repeatedly and quenched in water after each annealing. Oxide scale after annealing is removed by pickling with dilute nitric acid (10 % by volume) followed by washing with distilled water and drying.

Dimensions in millimetres

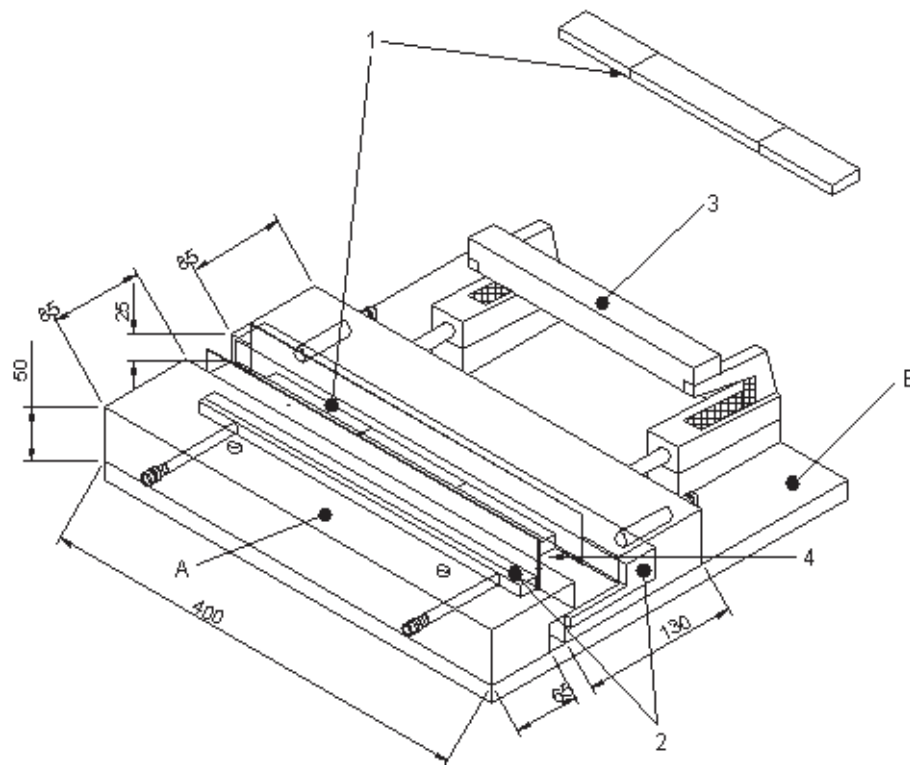

Key

- 1 test piece assembly per Figure 2
- 2 water cooling jacket (if necessary)
- 3 lever clamp
- 4 copper foil inserts (1 mm × 15 mm min. × 300 mm)
- A copper
- B carbon steel

Figure 1 — Example of a suitable welding fixture and test piece assembly for weld deposits

4.1.3 Test piece assemblies

The test piece assembly shall be prepared from plain carbon non-rimming steel with a carbon content of not more than 0,18 % by mass and a sulfur content of not more than 0,02 % by mass. The assembly shall conform to the dimensions shown in Figure 2 for assembly A, assembly B, or assembly C, with a tolerance of $\pm 0,25$ mm on all dimensions except the length of the run-on and run-off pieces. The lengths shown in Figure 2 for the run-on and the run-off piece represent minimum values.

All surfaces shall be finished at right angles to ensure good contact between adjacent pieces during the welding operation. Each test piece assembly may be finished with one operation on a surface grinder so as to ensure a uniform width, or closer dimensional control may be exercised to obtain proper clamping. See 4.1.4 d) for evidence of proper clamping.

The centre test piece shall be numbered by engraving or stamping on the opposite side of that used for welding. The entire test piece assembly shall be degassed at $650\text{ °C} \pm 10\text{ °C}$ for 1 h and cooled in either a dry inert gas atmosphere or a vacuum. Alternatively, the test piece assembly may be degassed and cooled in air if the surface oxide layer is removed prior to testing. Degassed test piece assemblies shall be stored in a desiccator or under other suitable conditions to prevent oxidation of the test pieces. After numbering and removal of oxide, the mass, m_1 , of each centre test piece shall be determined to the nearest 0,1 g for assembly A or to the nearest 0,01 g for assembly B or assembly C.

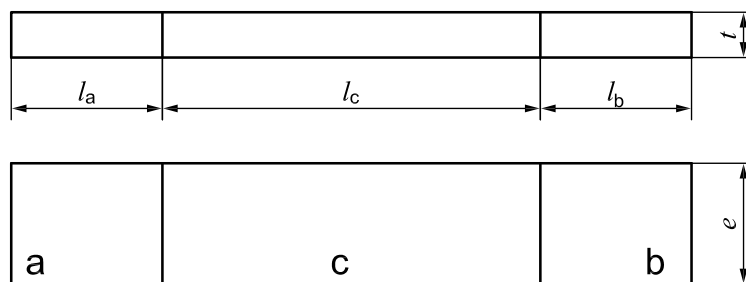

Key

- a run-on piece of length l_a
- b run-off piece of length l_b
- c centre test piece of length l_c
- e test piece width
- t test piece thickness

Dimensions in millimetres

Test assembly	l_a and l_b	l_c	e	t
A ^a	≥25 (50)	80	25	12
B	≥25 (50)	30	15	10
C	≥50	15	30	10
$l_a \geq 25$ mm and $l_b \geq 25$ mm: manual metal arc welding				
$l_a \geq 50$ mm and $l_b \geq 50$ mm: other welding processes				
^a Comparable to the specimen geometry according to AWS A4.3-93 ^[5] .				

Figure 2 — Dimensions of the weld test assembly

4.1.4 Welding and test piece storage

The temperature of the welding fixture before each weld is made shall be ambient or not more than 25 °C above ambient. If difficulty is caused by condensation of water on the fixture and test piece assembly, it is necessary to use cooling water thermostatically controlled to ambient temperature or as much as 25 °C higher. Using the welding process as specified in 4.2, and parameters appropriate to the type of investigation, a single weld bead shall be made on the test piece assembly that is clamped in the welding fixture as shown in Figure 1.

The test piece assembly shall be cleaned in acetone prior to being clamped into the welding fixture. Copper foil strips, as shown in Figure 1, shall be used to facilitate thermal transfer and prevent erosion of the fixture.

The welding procedure is specified in steps a) to f).

- a) Welding shall be initiated on the run-on piece at a point sufficiently distant from the centre test piece such that a stable arc and a stable deposit shape are achieved before reaching the centre test piece.
- b) Welding shall be terminated when the trailing edge of the crater is on the run-off piece but shall not exceed a distance of 25 mm from the centre test piece.
- c) After extinction of the arc, the clamp shall be released and the test piece assembly removed and immersed at $4 \text{ s} \pm 1 \text{ s}$ in an ice water bath. After $20 \text{ s} \pm 2 \text{ s}$, the test piece assembly shall be transferred and completely immersed in a low-temperature bath containing, for example, methanol and solid carbon

dioxide, denatured alcohol and solid carbon dioxide or liquid nitrogen. After removal of the specimen from the ice water, ice shall still be present in the bath.

- d) After a minimum of 2 min, the test assembly may be removed from the low temperature bath for cleaning and inspection. All slag and welding fume residue shall be removed by steel wire brushing. The run-on and run-off pieces shall be broken off from the centre test piece. The underside of this piece shall be examined to assess the uniformity and extent of heat tinting. Properly aligned and clamped test assemblies shall show parallel and uniform heat tinting of the underside of the centre test piece. Dark oxidation shall not extend to the edges of the underside of the centre test piece. If this entire operation is not completed within 60 s, the centre test piece shall be returned to the low temperature bath for a minimum of 2 min before completing these steps.
- e) Centre test pieces may be stored at $-78\text{ }^{\circ}\text{C}$ or lower in a methanol and solid carbon dioxide or denatured alcohol and solid carbon dioxide bath for a period of up to 72 h or at $-196\text{ }^{\circ}\text{C}$ in liquid nitrogen for a period of up to 21 days before analysis.
- f) For purposes of classifying welding consumables, during welding of the test assembly, the ambient absolute humidity shall be at least 3 g of water vapour per 1 000 g of dry air. (This corresponds to $20\text{ }^{\circ}\text{C}$ and 20 % relative humidity.) When the relative humidity, measured using a sling hygrometer or other calibrated device, equals or exceeds this condition, the test shall be acceptable as demonstrating compliance with the requirements of this International Standard provided the actual test results satisfy the diffusible hydrogen requirements of the applicable consumable classification standard. (The measurement of relative humidity can be easily converted to absolute humidity and reported as such.)

4.1.5 Recording of data

All relevant welding data, as shown on the data sheets, shall be recorded on the appropriate weld data sheet. Reference should be made to the suggested report forms for each welding process data sheet (see Tables 1, 2, and 3). Ambient conditions of temperature and humidity at the time of welding shall also be recorded and absolute humidity reported with the analytical results.

4.2 Welding procedures for the production of weld specimens

4.2.1 Summary

The operating parameters of the welding process under investigation shall be defined to produce a single weld bead on a test piece assembly as specified in 4.1. See 4.2.2 to 4.2.4 for specifications of the procedures for different welding processes.

4.2.2 Manual metal arc welding

4.2.2.1 Electrodes

The covered electrode to be tested shall be used in one of the ways a) or b).

- a) For purposes of classification, the electrode and the method of deposition of the weld shall be as specified in the standard with which the electrode complies.
- b) For purposes of investigation, the electrode and welding parameters shall be those given in the specific welding procedure. If no procedure has been given, then a current that is 90 % of the maximum suggested by the manufacturer shall be used.

When a predrying treatment is required, the time and temperature specified by the consumable manufacturer shall be used. If a range is given by the manufacturer, e.g. $300\text{ }^{\circ}\text{C}$ to $350\text{ }^{\circ}\text{C}$, then the average shall be used and reported.

Electrodes with cracked or broken coatings shall not be used. Electrodes to be tested in the as-received condition shall be taken from a freshly opened undamaged package. During any drying treatment, the

electrodes shall not touch each other or the side of the oven. During any drying operation, a calibrated oven shall be used and the electrodes shall spend the full specified time at the drying temperature. Only electrodes under test shall be placed in the oven during this time. When the drying operation is complete, the electrode shall be cooled to ambient temperature in a container, e.g. a dried borosilicate glass tube sealed with a rubber bung. The electrode shall be used as soon as possible after it reaches ambient temperature, but not more than 1 h after removal from the oven unless securely sealed. Any electrodes removed from the drying oven and not then used shall not be redried and subsequently used for the test.

When electrodes are to be tested in the as-received condition from a hermetically sealed container, the electrodes shall be protected from moisture pickup once the seal is broken, until each can be welded. Some sealed containers are resealable. In such a case, each test electrode can be withdrawn individually and the container resealed while the withdrawn electrode is welded. If the container is not resealable, then all of the test electrodes shall be withdrawn when the seal is broken, and each electrode shall be individually placed in a dried borosilicate glass tube sealed with a rubber bung until the electrode is to be used for test.

4.2.2.2 Making the test welds

A copper fixture, such as that shown in Figure 1, shall be used for the alignment and clamping of the test piece assembly. The fixture may incorporate water cooling channels in order to achieve a faster throughput of test pieces. Either test piece assembly A or assembly B may be used.

If the classification standard is silent on this matter, the following shall apply. The classification of covered electrodes is carried out using 4 mm diameter electrodes. In this case, the welding current shall be 15 A less than the maximum or 90 % of the maximum stated by the manufacturer, being maintained within a tolerance of ± 10 A. For an electrode with a diameter of 4 mm, the speed of welding shall be adjusted to produce an 8 g minimum weld deposit on the centre test piece assembly A or a 3 g minimum weld deposit on the centre test assembly B, which is usually accomplished with an electrode consumption of between 1,2 cm and 1,3 cm per centimetre of weld. Record welding parameters and calculate heat input in accordance with ISO/TR 17671-1. For all consumable diameters other than the 4 mm specified above, the weld deposit sample mass shall be representative of good welding practice and appropriate for the diameter and process applied; no minimum weld deposit sample mass is specified.

Three or more test welds shall be made on three or more test piece assemblies using a new electrode for each weld. The deposit shall be made, without weaving, along the centre line of the test piece assembly, as shown in Figure 1. The lengths of the run-on and of the run-off pieces shall be 25 mm minimum. No burning off prior to testing shall be allowed. The run-on deposit length shall not exceed 25 mm. The time spent in deposition shall be noted. Welding shall be terminated when the trailing edge of the crater is on the run-off piece, but shall not exceed a distance of 25 mm from the centre test piece.

The method of using the welding fixture is specified in 4.1.4. When welding is completed, the weld specimen shall be quenched and stored as specified in 4.1.4, after which it shall be cleaned and analysed for hydrogen content as specified in 4.3.

At the time of welding, due to the influence of atmospheric moisture on the test results, for purposes of classifying covered electrodes, the arc length shall be maintained as short as possible consistent with maintaining a steady arc. For all purposes, the details listed in 4.2.2.3 shall be recorded.

4.2.2.3 Recording of welding data and results report form

The report sheet given in Table 1 provides full details of all the test variables that pertain to the test results.

Table 1 — Report form (diffusible hydrogen, manual metal arc)

Investigating laboratory:		Date:		
Investigator's name:				
Brand name & electrode maker:		Batch No.:		
Type of electrode:		Electrode designation:		
Diameter of electrode (mm):		Overall length of electrode (mm):		
Drying treatment: °C for h				
Electrode polarity (d.c. + ve, d.c. – ve or a.c.):				
Relative humidity % and temperature °C at the welding station during welding				
Hydrogen extraction temperature: °C				
Hydrogen extraction time: days h min				
Type of test piece assembly (A or B):				
Number of test piece:	1	2	3	
Voltage, V; a.c. or d.c.:				
Current, A:				
Welding time, s:				
Weld length, mm:				
Heat input, kJ/mm:				
Electrode length used, mm:				
Run-on length, mm:				
Mass of deposited metal on test piece, g:				
Test piece to crater distance, mm:				
Diffusible hydrogen				
	1	2	3	Average
a) H_D , ml/100 g of deposited metal:				
b) H_F , ppm of fused metal:				
Other test details not included above:				

4.2.3 Submerged arc welding

4.2.3.1 Electrode wire

The consumable solid or cored wire to be tested shall be used in one of the ways a) or b).

- a) For purposes of classification, the welding parameters shall be the same as those used in the preparation of the all-weld-metal test assembly for mechanical property determination using 4 mm electrode wire, with travel speed adjusted to provide a deposit mass on the centre test piece of 8 g minimum (assembly A) or 3 g minimum for the smaller centre test piece (assembly C), unless otherwise specified in the classification document. Test piece assembly B is not acceptable for submerged arc welds. For all consumable diameters other than the 4 mm specified above, the weld deposit sample mass shall be representative of good welding practice and appropriate for the diameter and process applied; no minimum weld deposit sample mass is specified.

- b) For purposes of investigation, the electrode wire and welding parameters shall be those given in the specific welding procedure. The use of a solid wire that has been degassed in a vacuum or inert gas at 650 °C for 1 h facilitates the investigation of the effect of welding parameters, and type of flux and its drying procedure, upon the hydrogen content of the weld.

The arc energy for making the weld is restricted to a maximum of 3 kJ/mm.

4.2.3.2 Flux

When drying is required, the flux shall be dried in one of the ways a) or b).

- a) For purposes of classification, drying shall be done in accordance with the requirements of the standard with which the flux complies. Any preconditioning or drying of the flux shall be reported when an "H" designator is affixed to the flux classification.
- b) For purposes of investigation, drying shall be done in accordance with the appropriate recommendations.

Approximately 1 kg of flux is required for three welds. Drying shall be done in an open container placed in a calibrated drying oven set at the correct temperature. Flux depth should be limited in order to ensure that the entire mass of flux reaches the required temperature.

The flux shall spend the full specified time at the drying temperature and other fluxes shall not be placed in the oven during this time. When the drying treatment is complete, the flux shall be cooled to ambient temperature and used immediately. Alternatively, the flux shall be cooled in a sealed container and stored until required for use. Used flux shall not be recycled.

4.2.3.3 Making the test welds

A copper fixture, such as that shown in Figure 1, shall be used for the alignment and clamping of the test piece assembly. The fixture may incorporate water cooling channels in order to achieve a faster throughput of test pieces. Either test piece assembly A or assembly C may be used.

The centre piece remains the same size as specified in 4.1.3, but is aligned with longer run-on and run-off pieces of 50 mm minimum. The preparation, degassing, and use of the test piece assembly are specified in 4.1.3. The flux is kept at a predetermined constant depth of 25 mm or as recommended by the manufacturer. One method of controlling flux depth is by levelling off along the top of the copper foil inserts shown in Figure 3. The flux depth of 25 mm or a different flux depth specified by the flux manufacturer, determines whether the dimension of the copper foil should be modified in order to achieve the specified flux depth. At the end of the copper foil, there shall be a suitable piece of copper foil to contain the flux.

Three or more test welds shall be made on different test piece assemblies. The deposit shall be along the centre line of the test piece assembly. The time spent in deposition shall be noted. The trailing end of the crater shall be entirely on the run-off piece, but no further than 25 mm from the centre test piece for submerged arc welding. No length for the run-on portion of the weld deposit is specified, but the length shall be sufficient to achieve arc and deposit stability before reaching the centre test piece.

After extinction of the arc, and without any delay, the test piece assembly shall be released from the fixture and the test piece quenched, cleaned, and stored as specified in 4.1.4.

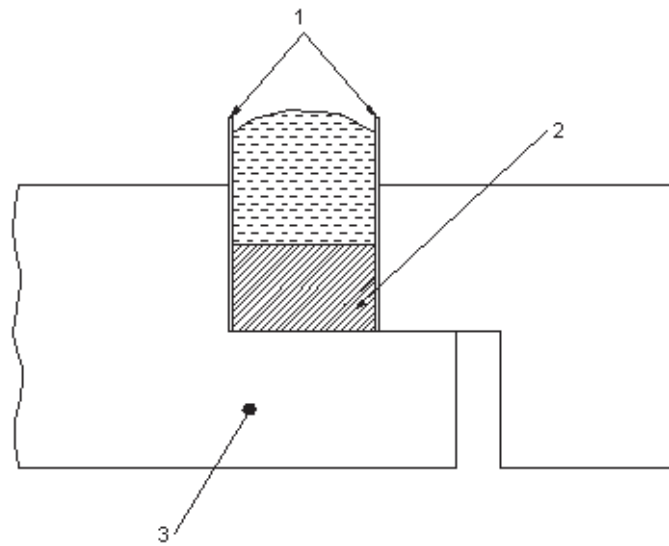

Key

- 1 1 mm copper foil, of dimensions 35 mm × 300 mm or 37 mm × 300 mm (for flux depth of 25 mm)
- 2 test piece assembly
- 3 welding fixture

Figure 3 — Example of the use of copper foil to maintain constant flux depth

4.2.3.4 Recording of welding data and results report form

The report sheet given in Table 2 provides full details of all the test variables that pertain to the test results.

Table 2 — Report form (diffusible hydrogen, submerged arc)

Investigating laboratory:	Date:			
Investigator's name:				
Electrode diameter, mm:	Electrode designation:			
	Flux designation:			
Brand name & electrode maker:	Batch No.:			
Brand name & flux maker:	Batch No.:			
Flux drying temperature and time:°C for h				
Electrode polarity (d.c. +ve, d.c. -ve or a.c.):				
Relative humidity% and temperature°C at the welding station during welding				
Hydrogen extraction temperature:°C				
Hydrogen extraction time:daysh.....min				
Type of test piece assembly (A or C):				
Number of test piece:	1	2	3	
Voltage, V; a.c. or d.c.:				
Current, A:				
Welding time, s:				
Weld length, mm:				
Welding speed, mm/s:				
Heat input, kJ/mm:				
Wire feed speed, mm/s:				
Contact tube distance, mm:				
Run-on length, mm:				
Mass of deposited metal on test piece, g:				
Test piece to crater distance, mm:				
Diffusible hydrogen				
	1	2	3	Average
a) H_D , ml/100 g of deposited metal:				
b) H_F , ppm of fused metal:				
Other test details not included above:				

4.2.4 Tubular cored electrode with or without gas shield and wire electrode with gas shield

4.2.4.1 Filler material

The filler material to be tested shall be used in one of the ways a) or b).

- a) For purposes of classification, the welding parameters shall be the same as those used in the preparation of the all-weld-metal test assembly for mechanical property determination using a 1,2 mm wire electrode, with travel speed adjusted to obtain a weld deposit mass on the centre test piece of 8 g minimum (assembly A) or 3 g minimum for the smaller centre test piece (assembly B), unless otherwise specified in the classification document. It is well established that diffusible hydrogen results from tubular cored electrodes are strongly affected by the electrode extension. Care shall be taken that the contact tip to work distance used for the diffusible hydrogen test is the same as that used in preparing the all-weld-metal test coupon for mechanical property determination. For all consumable diameters other than the 1,2 mm specified above, the weld deposit sample mass shall be representative of good welding practice and appropriate for the diameter and process applied; no minimum weld deposit sample mass is specified.
- b) For investigation purposes, the filler material and welding parameters shall be those given in the appropriate welding procedure. If a current range is given by the manufacturer, then the average shall be used.

4.2.4.2 Shielding gas

The shielding gas shall be of a welding grade as specified in ISO 14175. The shielding gas used and gas flow shall be in accordance with the appropriate recommendations. Details of the shielding gas composition and flow shall be recorded on the report form. For investigation purposes, it may sometimes be necessary to dry the shielding gas in order to remove moisture. If this is done, then the moisture content of the gas shall be measured and reported.

4.2.4.3 Making the test welds

A copper fixture such as that shown in Figure 1, shall be used for the alignment and clamping of the test piece assembly. The fixture may incorporate water-cooling channels in order to achieve a faster throughput of test pieces. Either test piece assembly A or assembly B may be used.

The run-on and run-off pieces of the test piece assemblies shall have a minimum length of 25 mm. The test piece assembly shall be clamped in the fixture using annealed copper foil as shown in Figure 1.

Three or more test welds shall be made on different test piece assemblies. The deposit shall be along the centre line of the test piece assembly and weld deposit masses shall be as specified in 4.2.4.1. The time spent in deposition shall be noted. The trailing end of the crater shall be on the run-off piece, but at a maximum distance of 25 mm from the centre test piece. No length for the run-on portion of the weld deposit is specified, but the length shall be sufficient to achieve arc and deposit stability before reaching the centre test piece.

After extinction of the arc and without any delay, the test piece assembly shall be released from the fixture and the test piece quenched, cleaned, and stored as specified in 4.1.4.

4.2.4.4 Recording of welding data and results report form

The report sheet given in Table 3 provides full details of all the test variables that pertain to the test results.

Table 3 — Report form (diffusible hydrogen, MIG, MAG, TIG or cored electrode)

Investigating laboratory:		Date:		
Investigator's name:				
Type of filler material:	Drying treatment: °C for h			
Filler material designation:		Gas cup i.d., mm:		
Brand name and electrode maker:	Batch No.:	Diameter of filler material, mm:		
Shielding gas:				
Shielding gas flow, l/min:				
Electrode polarity (d.c. + ve, d.c. -ve or a.c.):		Details of tungsten electrode, if any :		
		Make:		
Relative humidity % and temperature °C at the welding station during welding		Diameter, mm:		
Hydrogen extraction temperature: °C		Cone angle:		
Hydrogen extraction time: daysh min		Designation		
Type of test piece assembly (A or B):				
Number of test piece:	1	2	3	
Voltage, V; a.c. or d.c.:				
Current, A:				
Welding time, s:				
Weld length, mm:				
Welding speed, mm/s:				
Heat input, kJ/mm:				
Wire feed speed, mm/s:				
Contact tube distance, mm:				
Run-on length, mm:				
Mass of deposited metal on test piece, g:				
Test piece to crater distance, mm:				
Diffusible hydrogen				
	1	2	3	Average
a) H_D , ml/100 g of deposited metal:				
b) H_F , ppm of fused metal:				
Other test details not included above:				

4.3 Measurement of hydrogen in the test weld

The measurement method shall ensure that only diffusible hydrogen is released from the test specimen and is collected, and material-dependent activation of potential trapped hydrogen sources shall be avoided. Two methods of diffusible hydrogen analysis are specified in this International Standard, displacement of mercury and thermal conductivity detection.

4.3.1 Displacement of mercury method

The gas collection apparatus specified in this clause is known as a Y-tube and mercury shall be used as the collecting fluid. Other designs of collecting may be used, provided the same principles as for the Y-tube are used. The gas collection apparatus specified is for use with test centre piece assembly B or assembly C (see Figure 2).

4.3.1.1 Preparation of gas burette

The volume of mercury required to fill the size of a gas burette illustrated in Figure 4 is about 110 ml. The mercury shall be free of contaminants. The mercury shall be poured into the wide limb of the gas burette, the two-way vacuum stopcock shall be fitted and vacuum applied. Air shall be removed by laying the gas burette on a flat surface so as to allow an unrestricted application of the vacuum to the top of the capillary tube. The gas burette shall be slowly raised to the vertical position and air admitted to the wide limb by rotating the stopcock. It is important that there is no air bubble at the top of the capillary tube. If air is present, then the evacuation process shall be repeated until a final check confirms the absence of air. The vacuum stopcock shall be removed from the wide limb of the gas burette.

4.3.1.2 Test piece cleaning and handling

The centre test piece shall be cleaned by thorough brushing to remove all slag and oxide using a steel wire brush, in good condition, with intermittent periods of cooling (2 min minimum). Each interval spent outside the cooling bath during this operation shall not exceed 60 s [see also 4.1.4 d) and 4.1.4 e)].

4.3.1.3 Test piece loading

The following part of the procedure shall be carried out as quickly as possible, taking not more than approximately 2 min.

The test piece shall be removed from the storage coolant and raised to slightly above 0 °C. This can be conveniently achieved by immersing the test piece in water until the ice which forms initially has detached or melted.

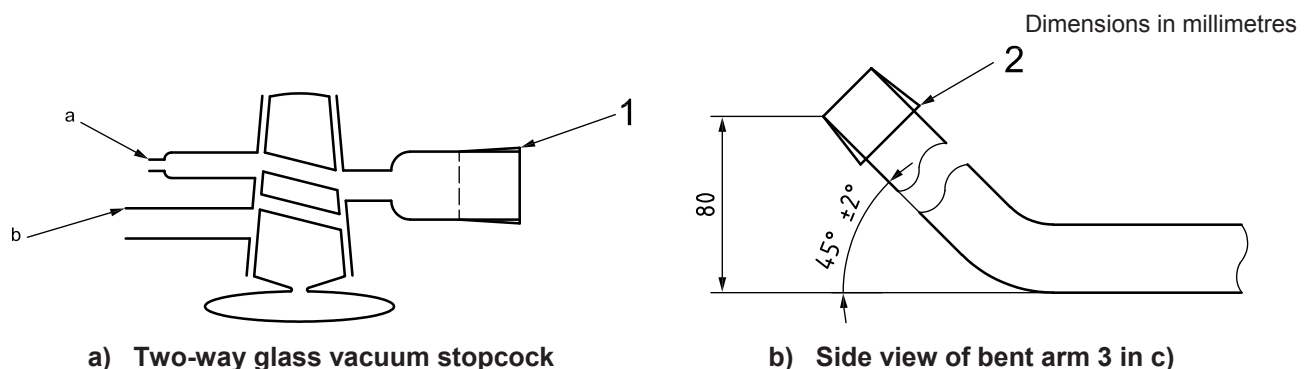
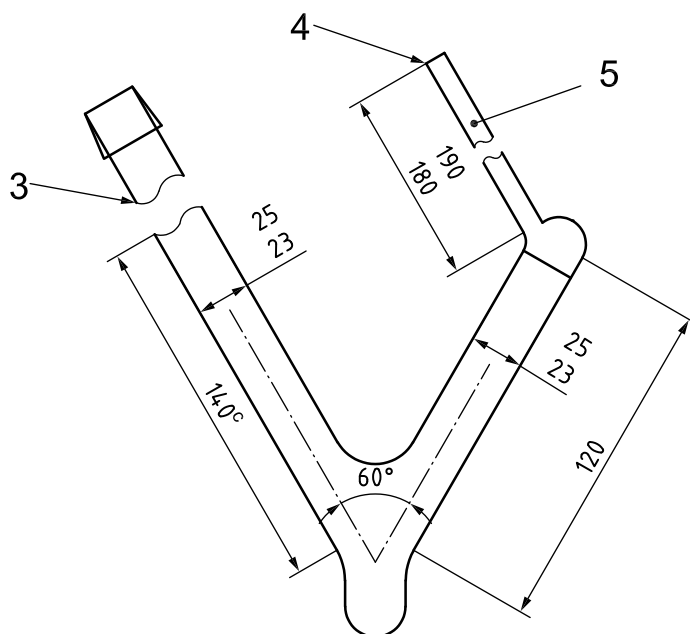

Figure 4 (continued)



c) Overall view of Y-tube

Key

- 1 29/32 socket
- 2 29/32 cone
- 3 Arm bent up 45° [see Figure 4 b)]
- 4 Seal (flat inside)
- 5 Precision bore tube

NOTE Not to scale.

- a To air.
- b To vacuum.
- c Straight portion before bend.

Figure 4 — Diffusible hydrogen collecting apparatus, Y tube

Following a rinse with acetone and drying in a jet of air, the test piece shall be transferred to the wide limb of the burette. The two-way vacuum stopcock shall be closed and the burette evacuated. Acetone and traces of condensed water evaporate from the surface of the test piece and are removed with the evacuated air. Using a magnet, the test piece shall be manoeuvred into position under the capillary tube by carefully lowering the burette towards the horizontal position until it just floats along the mercury surface. It is essential that care be taken to prevent air from entering the capillary tube when the burette is raised to the vertical position and air is admitted to the wide limb. The two-way stopcock shall be removed and the wide limb closed by means of a stopper or a glass cap, for example, to prevent the release of traces of mercury vapour.

Diffusible hydrogen is evolved from the test piece and collects in the capillary tube.

WARNING — Metallic mercury and mercury vapours are hazardous and can be absorbed into the body by inhalation, ingestion, or contact with the skin. All precautions involving the handling of mercury should be observed, which include but are not limited to the following:

- a) the diffusible hydrogen test apparatus should be located under a fume hood, and any steps involving the handling of mercury should be performed under a fume hood;
- b) the apparatus should be located on a tray or counter with a raised lip to contain any possible spills;

- c) plastic or rubber gloves should be used at all times when handling mercury or mercury-contaminated samples and equipment;
- d) any mercury spill should be cleaned up immediately.

4.3.1.4 Analytical procedure

The test piece shall be maintained at $25\text{ °C} \pm 5\text{ °C}$, until there is no increase in calculated hydrogen volume, corrected to standard temperature and pressure (STP), i.e. 0 °C and 760 mmHg^1 , on successive days. "No increase" can be understood as allowing for a change, over 24 h, of no more than 1 % of the total volume collected. The length of the hydrogen gas column and the head of mercury shall be measured using a cathetometer. Room temperature and atmospheric pressure shall be measured and recorded. The volume of hydrogen collected, corrected to STP, V , in millilitres, is given by the following equation:

$$V = \frac{273 \times (p - h)\pi r^2 C}{760 \times (273 + T) \times 1000} \quad (1)$$

where

- p is the atmospheric pressure, in millimetres of mercury;
- h is the differential head, in millimetres, of mercury between the two limbs of the Y-tube;
- r is the inside radius, in millimetres, of the capillary tube;
- C is the length, in millimetres, of the gas column above the mercury in millimetres;
- T is the room temperature, in degrees Celsius, at the time of hydrogen measurement.

When evolution has ceased, the test piece shall be removed from the apparatus and its final mass m_2 , in grams, shall be determined, to the nearest 0,01 g. All the relevant data shall be recorded.

4.3.2 Thermal conductivity detector method

In general, systems utilizing a thermal conductivity detector fall into one of two types: the first is hot carrier gas extraction where the specimen is heated at a relatively high temperature (up to 400 °C) and the diffusible hydrogen is evolved from the specimen and measured continuously. The second type is where the specimen is loaded into a suitable collection chamber that is heated at a relatively lower temperature (typically between 45 °C and 150 °C). Quantification of the hydrogen collected is performed as a separate step, typically utilizing a gas chromatography device.

It is not the objective of this International Standard to specify the several systems that are based on the thermal conductivity detector (TCD), e.g. gas chromatography or hot carrier gas extraction, that are available for the measurement of hydrogen in metals. However, it is important to note that any alternative system incorporating the facility for measuring the hydrogen in weld metal has to provide a proper correlation, in terms of accuracy and reproducibility. Particularly, the calibration procedures may be different for the individual measurement systems typically utilizing gas chromatography and a TCD. The manufacturer's instructions shall be followed for the gas extraction and thermal conductivity detection equipment. This device may be a gas chromatography device. This method is valid for the centre test piece assembly A, B or C.

4.3.2.1 Test piece cleaning and handling

The centre test piece shall be cleaned by thorough brushing to remove all slag and oxide using a steel wire brush, in good condition, with intermittent periods of cooling. The intervals spent outside the cooling bath during this operation shall not exceed 60 s [see also 4.1.4 d) and 4.1.4 e)].

1) $760\text{ mmHg} \equiv 101,325\text{ kPa}$.

4.3.2.2 Test piece loading

The centre test piece shall be removed from the methanol and solid carbon dioxide bath, denatured alcohol and solid carbon dioxide bath or liquid nitrogen bath and raised to slightly above 0 °C. This can be conveniently achieved by immersing the test piece in water until the ice which forms initially has detached or melted. The test piece shall be rinsed in acetone, dried in an air jet, and loaded into a suitable container for collection of hydrogen. The container shall be purged and filled with an inert gas such as argon and isolated from the atmosphere.

4.3.2.3 Measurement method by hot carrier gas extraction

Hydrogen extraction is accomplished in this procedure within a short period of time (rapid method). The manufacturer's instructions shall be followed to operate the equipment. After warming the specimen in accordance with 4.3.2.2, it shall be loaded into a suitable container for the collection of hydrogen. The test piece and container may be heated up to a maximum of 400 °C for measurement of the diffusible hydrogen content. Collection and measurement of the hydrogen occurs continuously until all of the diffusible hydrogen is quantified. Exceeding the degassing temperature of 400 °C can lead to an activation of further hydrogen traps, thus elevating the apparent diffusible hydrogen results.

4.3.2.4 Measurement method for collection and subsequent measurement of hydrogen

After warming the specimen per 4.3.2.2, it shall be loaded into a suitable container for the collection of hydrogen. The container shall be purged and filled with an inert gas such as argon and sealed to the atmosphere. The container shall be transferred to an oven or other suitable heating device for collection of hydrogen per the operating conditions specified in Table 4.

Upon completion of the heating and collection period, the container shall be cooled to room temperature and analysed for hydrogen. This can be accomplished by analysing either the entire quantity of hydrogen evolved from the test piece or an aliquot that can be apportioned to the entire quantity. A TCD shall be used to quantify the amount of hydrogen present in the outgas mixture.

Conversion of the measured value to give the hydrogen volume at STP, V_H , in millilitres, shall be made as follows:

$$V_H = \frac{273}{(273 + T)} \times \frac{pV}{760} \quad (2)$$

where

p is the pressure, in millimetres of mercury, of the measured hydrogen volume;

V is the measured volume, in millilitres, of hydrogen;

T is the temperature, in degrees Celsius, of the measured hydrogen volume.

The test piece shall be removed from the container, weighed, and the mass, m_2 , recorded to the nearest 0,1 g for assembly A centre pieces or to the nearest 0,01 g for assembly B or C centre test pieces.

Table 4 — Minimum holding time at a given temperature for complete hydrogen evolution

Minimum extraction time h	Temperature °C
0,35	400 ± 3
0,4	390 ± 3
0,5	360 ± 3
1	285 ± 3
2	225 ± 3
3	195 ± 3
4	175 ± 3
5	160 ± 3
6	150 ± 3
8	140 ± 3
10	125 ± 3
12	120 ± 3
14	115 ± 3
15	110 ± 3
18	100 ± 3
36	70 ± 3
64	50 ± 3
72	45 ± 3

4.3.3 Calibration

The calibration shall be carried out by supplying a known hydrogen volume to the carrier gas hot extraction system over the working area of interest. The analysis instruments should preferably incorporate different closed gas calibration units with different volumes. The apparatus shall be assembled and operated following the instructions of the manufacturer. Depending on the analysis instrument, a sufficiently long gas flow time shall be assured for stabilization prior to analysis. During normal instrument use, any existing calibration shall be checked by gas dosing before analysis is attempted. The instrument preparation procedure shall also be adhered to. Checks shall be made at the start and completion of a series of analyses in order to ensure that no drift has occurred in the instrument calibration. The interval between drift checks shall not exceed 4 h. The detector shall be calibrated over the appropriate range of hydrogen.

4.3.4 Linearity

The linearity of response of the instrument may be judged by using linear regression analysis to fit the calibration data and then calculating the correlation R^2 . Values of R^2 close to unity indicate a high degree of correlation.

The range of hydrogen contents to be measured ranges from 0,05 ml to significantly over 1 ml at STP, when the entire diffused volume of hydrogen gas is captured and analysed. The range of hydrogen contents to be measured is significantly less when analysis is based on methods utilizing a gas sample taken from the collection container. Hydrogen injection shall cover the applicable range in order to confirm linearity of response.

4.3.5 Calculation and expression of results

4.3.5.1 Diffusible hydrogen in deposited metal H_D

The volume at STP of diffusible hydrogen in deposited metal, H_D , in millilitres per 100 g, shall be calculated from the following equation:

$$H_D = V_{\text{STP}} \times \frac{100}{m_2 - m_1} \quad (3)$$

where

V_{STP} is the volume, in millilitres, of hydrogen gas at STP;

m_2 is the final mass, in grams, of the test piece with deposited metal;

m_1 is the initial mass, in grams, of the test piece.

4.3.5.2 Diffusible hydrogen in fused weld metal H_F

In order to assess the diffusible hydrogen content in a welded joint, it is necessary to determine the diffusible hydrogen in the fused weld metal. In the calculation of the diffusible hydrogen in fused weld metal, not only the deposited metal is considered, but also the fused portions of the base material.

Thus, in determining the fused weld metal, the respective total weld volume, and hence also the hydrogen pickup in the base material, is taken into account. In general, for a given test sample, H_F is of the order of 50 % of H_D .

If the hydrogen content is required in terms of concentration in the fused metal, it is necessary to measure the cross-sectional area of the fused metal and of the deposited metal. These shall be measured on the ends of the test piece by using an enlarged tracing or photograph, or an image-analysing microscope, and then averaging the results. Diffusible hydrogen in the fused weld, H_F , in parts per million by mass [ppm], shall be calculated from the following equation:

$$H_F = H_D \times 0,9 \times \frac{A_D}{A_F} \quad (4)$$

where

H_D is the diffusible hydrogen concentration, in millilitres per 100 g, in the deposited weld metal;

A_D is the average area of deposited weld metal;

A_F is the average area of fused metal.

4.3.6 Reporting of results

All data that are relevant to the interpretation of results shall be reported on the analysis data sheet given in Table 5 as appropriate for the method. The hydrogen concentration of each individual weld sample shall be calculated to one or two significant figures (as appropriate). For the purposes of this International Standard, the average value of the hydrogen concentration of triplicate welds, at a minimum, shall be calculated to the same number of significant figures and then rounded and reported to the nearest whole number for reporting in millilitres per 100 g.

The report forms given in Tables 1, 2, and 3 of this International Standard are used to report details of the welding consumable, the welding parameters, and test conditions for each set of triplicate welds. The results of the hydrogen measurements shall be recorded on the same forms.

Where applicable, rounding shall always be applied in one step. If there are two successive integral multiples equally near the given number, then the even integral multiple shall be selected as the rounded number.

Table 5 — Analysis data sheet

Date			
Method of diffusible hydrogen analysis:			
Hydrogen collection temperature: °C			
Hydrogen collection time: daysh			
Atmospheric pressure (recorded during measurement), p : mmHg			
Room temperature (recorded during measurement), T : °C			
Radius of capillary (Collection over mercury): mm			
Number of test piece:	1	2	3
Mass of centre test piece, m_1 , g:			
Mass of centre test piece plus weld, m_2 , g:			
Mass of deposited metal, $m_2 - m_1$, g:			
Average area of deposited metal, mm ²			
Average area of fused metal, mm ²			
Length of hydrogen gas column, C , mm:			
Head of mercury in capillary, h , mm:			

4.4 Measurement of total hydrogen content in the weld metal — Rapid methods

Specification of an elevated degassing temperature for the total hydrogen content (diffusible plus trapped) is only possible with knowledge of the activation energy of the hydrogen traps depending on the material to be investigated. For determination of the total hydrogen content, a melt extraction method can be applied.

Higher than 400 °C, analysis for total hydrogen, which includes residual hydrogen, can be achieved. The condition of the sample surface has a marked effect upon the measured hydrogen volume when methods involving heating above about 500 °C are used.

4.5 Rounding procedure

For purposes of the requirements of this International Standard, the actual test values obtained shall be subjected to the rounding rules of ISO 80000-1:2009, Annex B, Rule A. If the measured values are obtained by equipment calibrated in units other than those of this International Standard, the measured values shall be converted to the units of this International Standard before rounding. If an average value is to be compared to the requirements of this International Standard, rounding shall be done only after calculating the average.

Annex A (informative)

Recommendations and restrictions in regard to older methods of measurement using mercury

Older practices of hydrogen evolution for 72 h at approximately 20 °C are likely to result in appreciably less than complete hydrogen evolution, unless cleaning after welding is perfect. Only 67 % to 80 % of the total diffusible hydrogen may be collected. Therefore, consumables tested in accordance with this International Standard may be given a higher hydrogen classification than they would have been given under ISO 3690:1977 or DIN 8572-1^[3] 2), for example, without any change in the real product. The larger centre test piece specified in the current edition of this International Standard allows adequately reliable detection of still lower hydrogen levels, as well as better comparison to other standards such as AWS A4.3-93^[5].

2) Superseded by this International Standard.

Annex B (informative)

Recommendations and restrictions in regard to older methods of measurement using glycerin

Older practices of hydrogen evolution using glycerin are likely to result in appreciably less than complete hydrogen detection. Studies have shown that the use of glycerin as a collection medium results in severe lab-to-lab variation and inaccurate results. This is in part due to the absorption of oxygen, nitrogen, other gases, and water by the glycerin.

Annex C (informative)

Accuracy and reproducibility

C.1 General

If an alternative method other than displacement of mercury or thermal conductivity detection is used for diffusible hydrogen analysis, then the accuracy and reproducibility of the method shall be determined.

C.2 Accuracy

To assess the equivalence of the alternative method, a statistical comparison of preferably identical weld metal specimens is made. Ten specimens are arbitrarily divided into two groups. One group is analysed by the alternative method and the other group is analysed by either the mercury or thermal conductivity method. The accuracy of the alternative method shall be determined at several levels of hydrogen content. Ten identical specimens are required for each level of hydrogen. The accuracy of the alternative method is then judged by assessing the statistical significance of the difference in means of the two sets of results at each hydrogen level using the confidence interval approach. The following formula is used to calculate the confidence interval (CI) at the 95 % confidence level:

$$(\bar{x}_1 - \bar{x}_2) \pm 2,306 \sqrt{\frac{s_1^2}{5} + \frac{s_2^2}{5}} \quad (\text{C.1})$$

where

\bar{x}_1 is the mean of test pieces for the alternative method;

s_1 is the standard deviation of test pieces for the alternative method;

\bar{x}_2 is the mean of test pieces for the mercury or thermal conductivity method;

s_2 is the standard deviation of test pieces for the mercury or thermal conductivity method.

The confidence intervals for data from an international round robin test have been calculated for hydrogen at the nominal levels, in millilitres of H₂ per 100 g, of 0,5, 2, 4, 6, and 8. Using these calculated confidence intervals, an estimate of the range differences required to declare equivalence is $\pm 1,3$ at the 0,5 level and $\pm 2,9$ at the 2, 4, 6, and 8 levels.

C.3 Reproducibility

A series of repeat welds, analysed as indicated for the test on accuracy, also provides information on reproducibility.

Reproducibility is the consistency of replicate tests and is expressed by the standard deviation, s . A reproducibility index, $2s$, may be defined and in statistical terms 95 % of results would lie within a band $\bar{x} \pm 2s$, where \bar{x} is the mean value. A decrease in the numerical value of s implies an increase in reproducibility. The reproducibility index of the alternate method shall be equal to or less than the reproducibility index of the mercury or thermal conductivity method.

Bibliography

- [1] ISO 630 (all parts), *Structural steels*
- [2] ISO 2560, *Welding consumables — Covered electrodes for manual metal arc welding of non-alloy and fine grain steels — Classification*
- [3] DIN 8572-1, *Determination of diffusible hydrogen in weld metal — Manual arc welding*³⁾
- [4] Doc.IIS/IIW-452.74, Weld hydrogen levels and the definition of hydrogen controlled electrodes. *Weld. World* 1974, **12**(3–4), p. 69
- [5] AWS A4.3-93, *Standard methods for determination of the diffusible hydrogen content of martensitic, bainitic, and ferritic steel weld metal produced by arc welding*
- [6] VAN DER MEE, V. Effect of atmospheric storage conditions on weld metal diffusible hydrogen content of gas shielded cored wires (IIW document no. II-1437-01)
- [7] COE, F.R. Hydrogen measurements — Current trends versus forgotten facts (IIW document No. II-1079-86). *Metal Constr.* 1986, **18**, pp. 20-25

3) Superseded by this International Standard.

British Standards Institution (BSI)

BSI is the national body responsible for preparing British Standards and other standards-related publications, information and services.

BSI is incorporated by Royal Charter. British Standards and other standardization products are published by BSI Standards Limited.

About us

We bring together business, industry, government, consumers, innovators and others to shape their combined experience and expertise into standards-based solutions.

The knowledge embodied in our standards has been carefully assembled in a dependable format and refined through our open consultation process. Organizations of all sizes and across all sectors choose standards to help them achieve their goals.

Information on standards

We can provide you with the knowledge that your organization needs to succeed. Find out more about British Standards by visiting our website at bsigroup.com/standards or contacting our Customer Services team or Knowledge Centre.

Buying standards

You can buy and download PDF versions of BSI publications, including British and adopted European and international standards, through our website at bsigroup.com/shop, where hard copies can also be purchased.

If you need international and foreign standards from other Standards Development Organizations, hard copies can be ordered from our Customer Services team.

Subscriptions

Our range of subscription services are designed to make using standards easier for you. For further information on our subscription products go to bsigroup.com/subscriptions.

With **British Standards Online (BSOL)** you'll have instant access to over 55,000 British and adopted European and international standards from your desktop. It's available 24/7 and is refreshed daily so you'll always be up to date.

You can keep in touch with standards developments and receive substantial discounts on the purchase price of standards, both in single copy and subscription format, by becoming a **BSI Subscribing Member**.

PLUS is an updating service exclusive to BSI Subscribing Members. You will automatically receive the latest hard copy of your standards when they're revised or replaced.

To find out more about becoming a BSI Subscribing Member and the benefits of membership, please visit bsigroup.com/shop.

With a **Multi-User Network Licence (MUNL)** you are able to host standards publications on your intranet. Licences can cover as few or as many users as you wish. With updates supplied as soon as they're available, you can be sure your documentation is current. For further information, email bsmusales@bsigroup.com.

BSI Group Headquarters

389 Chiswick High Road London W4 4AL UK

Revisions

Our British Standards and other publications are updated by amendment or revision.

We continually improve the quality of our products and services to benefit your business. If you find an inaccuracy or ambiguity within a British Standard or other BSI publication please inform the Knowledge Centre.

Copyright

All the data, software and documentation set out in all British Standards and other BSI publications are the property of and copyrighted by BSI, or some person or entity that owns copyright in the information used (such as the international standardization bodies) and has formally licensed such information to BSI for commercial publication and use. Except as permitted under the Copyright, Designs and Patents Act 1988 no extract may be reproduced, stored in a retrieval system or transmitted in any form or by any means – electronic, photocopying, recording or otherwise – without prior written permission from BSI. Details and advice can be obtained from the Copyright & Licensing Department.

Useful Contacts:

Customer Services

Tel: +44 845 086 9001

Email (orders): orders@bsigroup.com

Email (enquiries): cservices@bsigroup.com

Subscriptions

Tel: +44 845 086 9001

Email: subscriptions@bsigroup.com

Knowledge Centre

Tel: +44 20 8996 7004

Email: knowledgecentre@bsigroup.com

Copyright & Licensing

Tel: +44 20 8996 7070

Email: copyright@bsigroup.com



...making excellence a habit.™