

BS EN ISO 3673-2:2012



BSI Standards Publication

## Plastics — Epoxy resins

Part 2: Preparation of test specimens and determination of properties of crosslinked epoxy resins (ISO 3673-2:2012)

**bsi.**

...making excellence a habit.™

**National foreword**

This British Standard is the UK implementation of EN ISO 3673-2:2012. It supersedes BS EN ISO 3673-2:2000 which is withdrawn.

The UK participation in its preparation was entrusted to Technical Committee PRI/42, Fibre reinforced thermosetting plastics and prepregs.

A list of organizations represented on this committee can be obtained on request to its secretary.

This publication does not purport to include all the necessary provisions of a contract. Users are responsible for its correct application.

© The British Standards Institution 2012. Published by BSI Standards Limited 2012

ISBN 978 0 580 74659 8

ICS 83.080.10

**Compliance with a British Standard cannot confer immunity from legal obligations.**

This British Standard was published under the authority of the Standards Policy and Strategy Committee on 31 August 2012.

**Amendments issued since publication**

Date	Text affected
------	---------------

---

English Version

## Plastics - Epoxy resins - Part 2: Preparation of test specimens and determination of properties of crosslinked epoxy resins (ISO 3673-2:2012)

Plastiques - Résines époxydes - Partie 2: Préparation des éprouvettes et détermination des propriétés des résines époxydes réticulées (ISO 3673-2:2012)

Kunststoffe - Epoxidharze - Teil 2: Herstellung von Probekörpern und Bestimmung von Eigenschaften von vernetzten Epoxidharzen (ISO 3673-2:2012)

This European Standard was approved by CEN on 14 July 2012.

CEN members are bound to comply with the CEN/CENELEC Internal Regulations which stipulate the conditions for giving this European Standard the status of a national standard without any alteration. Up-to-date lists and bibliographical references concerning such national standards may be obtained on application to the CEN-CENELEC Management Centre or to any CEN member.

This European Standard exists in three official versions (English, French, German). A version in any other language made by translation under the responsibility of a CEN member into its own language and notified to the CEN-CENELEC Management Centre has the same status as the official versions.

CEN members are the national standards bodies of Austria, Belgium, Bulgaria, Croatia, Cyprus, Czech Republic, Denmark, Estonia, Finland, Former Yugoslav Republic of Macedonia, France, Germany, Greece, Hungary, Iceland, Ireland, Italy, Latvia, Lithuania, Luxembourg, Malta, Netherlands, Norway, Poland, Portugal, Romania, Slovakia, Slovenia, Spain, Sweden, Switzerland, Turkey and United Kingdom.



EUROPEAN COMMITTEE FOR STANDARDIZATION  
COMITÉ EUROPÉEN DE NORMALISATION  
EUROPÄISCHES KOMITEE FÜR NORMUNG

Management Centre: Avenue Marnix 17, B-1000 Brussels

## Foreword

This document (EN ISO 3673-2:2012) has been prepared by Technical Committee ISO/TC 61 "Plastics" in collaboration with Technical Committee CEN/TC 249 "Plastics", the secretariat of which is held by NBN.

This European Standard shall be given the status of a national standard, either by publication of an identical text or by endorsement, at the latest by January 2013, and conflicting national standards shall be withdrawn at the latest by January 2013.

Attention is drawn to the possibility that some of the elements of this document may be the subject of patent rights. CEN [and/or CENELEC] shall not be held responsible for identifying any or all such patent rights.

This document supersedes EN ISO 3673-2:1999.

According to the CEN/CENELEC Internal Regulations, the national standards organizations of the following countries are bound to implement this European Standard: Austria, Belgium, Bulgaria, Croatia, Cyprus, Czech Republic, Denmark, Estonia, Finland, Former Yugoslav Republic of Macedonia, France, Germany, Greece, Hungary, Iceland, Ireland, Italy, Latvia, Lithuania, Luxembourg, Malta, Netherlands, Norway, Poland, Portugal, Romania, Slovakia, Slovenia, Spain, Sweden, Switzerland, Turkey and the United Kingdom.

### Endorsement notice

The text of ISO 3673-2:2012 has been approved by CEN as a EN ISO 3673-2:2012 without any modification.

# Contents

Page

Foreword .....	iv
<b>1</b> <b>Scope</b> .....	<b>1</b>
<b>2</b> <b>Normative references</b> .....	<b>1</b>
<b>3</b> <b>Preparation of test specimens</b> .....	<b>2</b>
<b>3.1</b> <b>General</b> .....	<b>2</b>
<b>3.2</b> <b>Pretreatment of materials</b> .....	<b>2</b>
<b>3.3</b> <b>Preparation of test sheets</b> .....	<b>2</b>
<b>3.4</b> <b>Cutting out test specimens</b> .....	<b>4</b>
<b>3.5</b> <b>Conditioning test specimens</b> .....	<b>4</b>
<b>4</b> <b>Determination of properties</b> .....	<b>4</b>
Bibliography .....	<b>6</b>

## Foreword

ISO (the International Organization for Standardization) is a worldwide federation of national standards bodies (ISO member bodies). The work of preparing International Standards is normally carried out through ISO technical committees. Each member body interested in a subject for which a technical committee has been established has the right to be represented on that committee. International organizations, governmental and non-governmental, in liaison with ISO, also take part in the work. ISO collaborates closely with the International Electrotechnical Commission (IEC) on all matters of electrotechnical standardization.

International Standards are drafted in accordance with the rules given in the ISO/IEC Directives, Part 2.

The main task of technical committees is to prepare International Standards. Draft International Standards adopted by the technical committees are circulated to the member bodies for voting. Publication as an International Standard requires approval by at least 75 % of the member bodies casting a vote.

Attention is drawn to the possibility that some of the elements of this document may be the subject of patent rights. ISO shall not be held responsible for identifying any or all such patent rights.

ISO 3673-2 was prepared by Technical Committee ISO/TC 61, *Plastics*, Subcommittee SC 12, *Thermosetting materials*.

This third edition cancels and replaces the second edition (ISO 3673-2:2007), which has been revised to make it clear that it applies only to crosslinked epoxy resins.

ISO 3673 consists of the following parts, under the general title *Plastics — Epoxy resins*:

- *Part 1: Designation*
- *Part 2: Preparation of test specimens and determination of properties of crosslinked epoxy resins*

# Plastics — Epoxy resins —

## Part 2:

# Preparation of test specimens and determination of properties of crosslinked epoxy resins

**SAFETY STATEMENT** — Persons using this document should be familiar with normal laboratory practice, if applicable. This document does not purport to address all of the safety concerns, if any, associated with its use. It is the responsibility of the user to establish appropriate safety and health practices and to ensure compliance with any regulatory requirements.

## 1 Scope

This part of ISO 3673 specifies the methods of preparation of test specimens and the test methods to be used in determining the properties of crosslinked epoxy resins. The properties determined have been selected from the general test methods in ISO 10350-1:2007.

Test methods for the determination of the properties of non-crosslinked epoxy resins are not included in this part of ISO 3673.

NOTE Test methods for non-crosslinked epoxy resins are specified in ISO 18280.

In order to obtain reproducible and comparable test results, it is necessary to use the test methods, sample preparation and conditioning, and specimen dimensions specified herein. Values determined will not necessarily be identical to those obtained using test specimens of different dimensions or prepared using different procedures.

Other standards exist concerning the determination of properties and preparation of test specimens for epoxy-based products, to which reference will be made, if required.

## 2 Normative references

The following referenced documents are indispensable for the application of this document. For dated references, only the edition cited applies. For undated references, the latest edition of the referenced document (including any amendments) applies.

ISO 62, *Plastics — Determination of water absorption*

ISO 75-2, *Plastics — Determination of temperature of deflection under load — Part 2: Plastics and ebonite*

ISO 178, *Plastics — Determination of flexural properties*

ISO 179-1, *Plastics — Determination of Charpy impact properties — Part 1: Non-instrumented impact test*

ISO 179-2, *Plastics — Determination of Charpy impact properties — Part 2: Instrumented impact test*

ISO 527-2, *Plastics — Determination of tensile properties — Part 2: Test conditions for moulding and extrusion plastics*

ISO 2577, *Plastics — Thermosetting moulding materials — Determination of shrinkage*

ISO 2818, *Plastics — Preparation of test specimens by machining*

ISO 3167, *Plastics — Multipurpose test specimens*

ISO 4589-2, *Plastics — Determination of burning behaviour by oxygen index — Part 2: Ambient-temperature test*

ISO 10350-1:2007, *Plastics — Acquisition and presentation of comparable single-point data — Part 1: Moulding materials*

ISO 11357-2, *Plastics — Differential scanning calorimetry (DSC) — Part 2: Determination of glass transition temperature*

ISO 11359-2, *Plastics — Thermomechanical analysis (TMA) — Part 2: Determination of coefficient of linear thermal expansion and glass transition temperature*

IEC 60093, *Methods of test for volume resistivity and surface resistivity of solid electrical insulating materials*

IEC 60112, *Method for the determination of the proof and the comparative tracking indices of solid insulating materials*

IEC 60243-1, *Electrical strength of insulating materials — Test methods — Part 1: Tests at power frequencies*

IEC 60250, *Recommended methods for the determination of the permittivity and dielectric dissipation factor of electrical insulating materials at power, audio and radio frequencies including metre wavelengths*

IEC 60296, *Fluids for electrotechnical applications — Unused mineral insulating oils for transformers and switchgear*

IEC 60695-11-10, *Fire hazard testing — Part 11-10: Test flames — 50 W horizontal and vertical flame test methods*

IEC 60695-11-20, *Fire hazard testing — Part 11-20: Test flames — 500 W flame test methods*

### 3 Preparation of test specimens

#### 3.1 General

This procedure is used only for the determination of crosslinked-resin properties.

It is essential that specimens are always prepared by the same procedure, using the same processing conditions. The specimens on which the properties are measured shall be cut from sheets of crosslinked resin, produced by a casting process. In view of the numerous possible fields of application for epoxy resins, the choice was made to prepare test specimens from resins not containing any filler or reinforcement in order to obtain the intrinsic properties of the crosslinked polymer, free of structural additives.

Sheets of thermosetting resin shall be manufactured at 2 mm, 3 mm and 4 mm thickness, as required, for the tests in Table 1. A sufficient number shall be produced to determine those properties required.

#### 3.2 Pretreatment of materials

Before casting, no treatment of the epoxy resin sample is normally necessary. If a pretreatment is required, this shall be in accordance with the manufacturer's recommendations.

#### 3.3 Preparation of test sheets

##### 3.3.1 Apparatus

**3.3.1.1 Two glass plates or two polished stainless-steel plates**, each having a thickness of 6 mm and approximate dimensions of 300 mm × 350 mm.

Other materials, such as silicone, may also be used.

**3.3.1.2 Shims**, having a thickness of 2 mm, 3 mm and 4 mm.

**3.3.1.3 Silicone or latex joint**, having a diameter of 5 mm.

**3.3.1.4 Device for clamping and holding the plates.**



**3.3.1.5 Device for removing air bubbles from the reaction mixture** (see 3.3.3.4), preferably a centrifuge, or a vacuum dessicator allowing the plate/joint/shim assembly to be put under a static vacuum.

**3.3.1.6 Stirrer**, for mixing the resin and crosslinking agent (e.g. a glass rod).

**3.3.1.7 Glass beaker**, capacity 500 ml.

**3.3.1.8 Laboratory balance**, accurate to 0,1 g.

**3.3.1.9 Laboratory oven**, set at the temperature chosen for carrying out the post-treatment of the epoxy resin.

### 3.3.2 Reagents

**3.3.2.1 Crosslinking agent**, specific to epoxy resins (e.g. methyltetrahydrophthalic anhydride) (see warning in 3.3.3.5).

**3.3.2.2 Crosslinking accelerator**, e.g. 2,4,6-tris(dimethylaminomethyl)phenol or *N,N*-dimethyl-benzylamine.

**3.3.2.3 External release agent**, which does not modify the properties of the crosslinked resin.

### 3.3.3 Procedure

**3.3.3.1** Coat the plates (3.3.1.1) with a thin layer of release agent (3.3.2.3). Polish them until they shine in order to ensure that the crosslinked-resin sheet produced has a high-quality surface finish.

**3.3.3.2** Arrange the silicone or latex joint (3.3.1.3) and the selected shim (2 mm, 3 mm or 4 mm) (3.3.1.2) between the two plates as shown in Figure 1. Clamp the assembly with a suitable clamp (3.3.1.4) and position vertically.

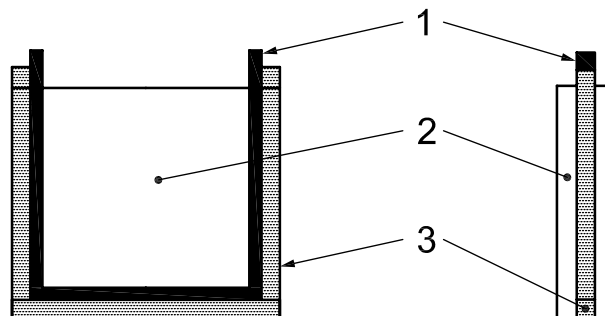

#### Key

- 1 joint
- 2 glass or steel plates
- 3 shims

**Figure 1 — Apparatus for preparing test sheets**

**3.3.3.3** Using a laboratory balance (3.3.1.8), weigh the following reagents into a glass beaker (3.3.1.7):

- 100 g of epoxy resin;
  - methyltetrahydrophthalic anhydride at an anhydride/epoxy equivalent ratio of 0,9/1;
  - 0,5 phr (parts per hundred parts of epoxy resin, by mass) of 2,4,6-tris(dimethylaminomethyl)phenol;
- or
- 2 phr (parts per hundred parts of epoxy resin, by mass) of *N,N*-dimethylbenzylamine.

Using the stirrer (3.3.1.6), mix until homogeneous, avoiding the introduction of air bubbles as much as possible.

**3.3.3.4** Remove any air bubbles from the mixture using the centrifuge (see 3.3.1.5), then carefully pour the mixture into the plate/joint/shim assembly without trapping any air bubbles in the resin. In the absence of a centrifuge, once the assembly is filled with the reactant mixture, place it vertically in a vacuum desiccator (see 3.3.1.5) and apply a static vacuum for the time required to remove all air bubbles.

When the viscosity of the mixture is high, air bubbles can be removed at an elevated temperature (e.g. 100 °C). In this case, the amount of accelerator has to be decreased. For example, use 0,25 phr of 2,4,6-tris(dimethylaminomethyl)phenol or 1 phr of *N,N*-dimethylbenzylamine.

**3.3.3.5** Maintain the assembly in the vertical position while crosslinking in the laboratory oven (3.3.1.9). If using methyltetrahydrophthalic anhydride with 2,4,6-tris(dimethylaminomethyl)phenol or *N,N*-dimethylbenzylamine for crosslinking, carry out the heat treatment for 2 h at 100 °C followed by 15 h at 150 °C.

**WARNING — Fumes from the crosslinking agent (methyltetrahydrophthalic anhydride) irritate the respiratory system and skin. Use ventilation and wear protective masks, gloves and goggles.**

## 3.4 Cutting out test specimens

Cut test specimens from the prepared sheets (thickness 2 mm, 3 mm or 4 mm) in accordance with ISO 2818.

## 3.5 Conditioning test specimens

Unless otherwise specified, condition the test specimens for at least 16 h at 23 °C ± 2 °C and (50 ± 5) % relative humidity prior to determining the properties in Table 1.

## 4 Determination of properties

**4.1** Properties are presented in Table 1.

**4.2** In the determination of intrinsic properties, the presentation of results, the standards, and the supplementary instructions and notes given in ISO 10350-1:2007 shall be applied. All the tests shall be carried out at 23 °C ± 2 °C and 50 % ± 5 % relative humidity unless specifically stated otherwise in Table 1. Table 1 is taken from ISO 10350-1:2007 and the properties listed are those which are appropriate to epoxy-based products. These properties are those considered useful for comparisons of data generated for different thermosets and thermoplastics.

Table 1 — Intrinsic properties and test conditions

	Property	Symbol	Standard	Specimen type (dimensions in mm)	Unit	Test conditions and supplementary instructions	
<b>1</b>	<b>Rheological properties</b>						
1.1	Moulding shrinkage of thermosetting polymers	$S_{Mp}$	ISO 2577	See ISO 2577	%	Parallel	
1.2		$S_{Mn}$				Normal	
<b>2</b>	<b>Mechanical properties</b>						
2.1	Tensile modulus	$E_t$	ISO 527-2	ISO 3167, type A	MPa	Test speed 1 mm/min	
2.2	Stress at break	$\sigma_B$			MPa	Failure without yielding $\sigma_B \leq 10\%$ : test speed 5 mm/min $\sigma_B > 10\%$ : test speed 50 mm/min	
2.3	Strain at break	$\epsilon_B$			%		
2.4	Flexural modulus	$E_f$	ISO 178	80 × 10 × 4	MPa	Test speed 2 mm/min Optional extra information for brittle materials	
2.5	Flexural strength	$\sigma_{fM}$					
2.6	Charpy impact strength	$a_{cU}$					
2.7	Charpy notched impact strength	$a_{cA}$	or ISO 179 2	Machined type A V-notch, $r = 0,25$			
<b>3</b>	<b>Thermal properties</b>						
3.1	Glass transition temperature	$T_g$	ISO 11357-2	Moulding compound	°C	Record midpoint temperature Use 10 °C/min	
3.2	Temperature of deflection under load	$T_f 1,8$	ISO 75-2	80 × 10 × 4	°C	1,80	Maximum surface stress (MPa)
3.3		$T_f 8,0$				8,0	
3.4	Coefficient of linear thermal expansion	$\alpha_p$	ISO 11359-2	Prepared from ISO 3167	°C <sup>-1</sup>	Parallel	Record secant value over the temperature range 23 °C to 55 °C
		$\alpha_n$				Transverse	
3.5	Burning behaviour	B50/3	IEC 60695-11-10	125 × 13 × 3		Record one of the classifications V-0, V-1, V-2, HB40 or HB75	
		B50/h		Greater thickness $h$			
3.6		B500/3	IEC 60695-11-20	≥ 150 × ≥ 150 × 3		Record classification 5VA, 5VB or N	
		B500/h		Greater thickness $h$			
3.7	Oxygen index	OI	ISO 4589-2	80 × 10 × 4	%	Use procedure A (top surface ignition)	
<b>4</b>	<b>Electrical properties</b>						
4.1	Relative permittivity	$\epsilon_r 100$	IEC 60250	≥ 60 × ≥ 60 × 2		100 Hz	Compensate for electrode edge effects
		$\epsilon_r 1M$				1 MHz	
4.2	Dissipation factor	$\tan \delta 100$				100 Hz	
		$\tan \delta 1M$				1 MHz	
4.3	Volume resistivity	$\rho_e$	IEC 60093	≥ 60 × ≥ 60 × 2	Ω·m	1-minute value	
4.4	Surface resistivity	$\delta_e$			Ω	Voltage 500 V	Use contacting line electrodes 1 mm to 2 mm wide, 50 mm long and 5 mm apart
4.5	Electric strength	$E_{B1}$	IEC 60243-1	≥ 60 × ≥ 60 × 1	kV/mm	Use 20-mm-diameter spherical electrodes. Immerse in transformer oil in accordance with IEC 60296. Use a voltage application rate of 2 kV/s.	
		$E_{B2}$		≥ 60 × ≥ 60 × 2			
4.6	Comparative tracking index	CTI	IEC 60112	≥ 20 × ≥ 20 × 4		Use solution A	
<b>5</b>	<b>Other properties</b>						
5.1	Water absorption	$W_W$	ISO 62	Thickness ≥ 1	%	Saturation value in water at 23 °C	
		$W_H$				Equilibrium value at 23 °C, 50 % RH	

## Bibliography

- [1] ISO 18280, *Plastics — Epoxy resins — Test methods*







# British Standards Institution (BSI)

BSI is the national body responsible for preparing British Standards and other standards-related publications, information and services.

BSI is incorporated by Royal Charter. British Standards and other standardization products are published by BSI Standards Limited.

## About us

We bring together business, industry, government, consumers, innovators and others to shape their combined experience and expertise into standards-based solutions.

The knowledge embodied in our standards has been carefully assembled in a dependable format and refined through our open consultation process. Organizations of all sizes and across all sectors choose standards to help them achieve their goals.

## Information on standards

We can provide you with the knowledge that your organization needs to succeed. Find out more about British Standards by visiting our website at [bsigroup.com/standards](http://bsigroup.com/standards) or contacting our Customer Services team or Knowledge Centre.

## Buying standards

You can buy and download PDF versions of BSI publications, including British and adopted European and international standards, through our website at [bsigroup.com/shop](http://bsigroup.com/shop), where hard copies can also be purchased.

If you need international and foreign standards from other Standards Development Organizations, hard copies can be ordered from our Customer Services team.

## Subscriptions

Our range of subscription services are designed to make using standards easier for you. For further information on our subscription products go to [bsigroup.com/subscriptions](http://bsigroup.com/subscriptions).

With **British Standards Online (BSOL)** you'll have instant access to over 55,000 British and adopted European and international standards from your desktop. It's available 24/7 and is refreshed daily so you'll always be up to date.

You can keep in touch with standards developments and receive substantial discounts on the purchase price of standards, both in single copy and subscription format, by becoming a **BSI Subscribing Member**.

**PLUS** is an updating service exclusive to BSI Subscribing Members. You will automatically receive the latest hard copy of your standards when they're revised or replaced.

To find out more about becoming a BSI Subscribing Member and the benefits of membership, please visit [bsigroup.com/shop](http://bsigroup.com/shop).

With a **Multi-User Network Licence (MUNL)** you are able to host standards publications on your intranet. Licences can cover as few or as many users as you wish. With updates supplied as soon as they're available, you can be sure your documentation is current. For further information, email [bsmusales@bsigroup.com](mailto:bsmusales@bsigroup.com).

## BSI Group Headquarters

389 Chiswick High Road London W4 4AL UK

## Revisions

Our British Standards and other publications are updated by amendment or revision.

We continually improve the quality of our products and services to benefit your business. If you find an inaccuracy or ambiguity within a British Standard or other BSI publication please inform the Knowledge Centre.

## Copyright

All the data, software and documentation set out in all British Standards and other BSI publications are the property of and copyrighted by BSI, or some person or entity that owns copyright in the information used (such as the international standardization bodies) and has formally licensed such information to BSI for commercial publication and use. Except as permitted under the Copyright, Designs and Patents Act 1988 no extract may be reproduced, stored in a retrieval system or transmitted in any form or by any means – electronic, photocopying, recording or otherwise – without prior written permission from BSI. Details and advice can be obtained from the Copyright & Licensing Department.

## Useful Contacts:

### Customer Services

**Tel:** +44 845 086 9001

**Email (orders):** [orders@bsigroup.com](mailto:orders@bsigroup.com)

**Email (enquiries):** [cservices@bsigroup.com](mailto:cservices@bsigroup.com)

### Subscriptions

**Tel:** +44 845 086 9001

**Email:** [subscriptions@bsigroup.com](mailto:subscriptions@bsigroup.com)

### Knowledge Centre

**Tel:** +44 20 8996 7004

**Email:** [knowledgecentre@bsigroup.com](mailto:knowledgecentre@bsigroup.com)

### Copyright & Licensing

**Tel:** +44 20 8996 7070

**Email:** [copyright@bsigroup.com](mailto:copyright@bsigroup.com)



...making excellence a habit.™