

BS EN ISO 3380:2015



BSI Standards Publication

**Leather — Physical and  
mechanical tests —  
Determination of shrinkage  
temperature up to 100° C**

**bsi.**

...making excellence a habit.™

**National foreword**

This British Standard is the UK implementation of EN ISO 3380:2015. It supersedes BS EN ISO 3380:2002 which is withdrawn.

The UK participation in its preparation was entrusted to Technical Committee TCI/69, Footwear, leather and coated fabrics.

A list of organizations represented on this committee can be obtained on request to its secretary.

This publication does not purport to include all the necessary provisions of a contract. Users are responsible for its correct application.

© The British Standards Institution 2015.  
Published by BSI Standards Limited 2015

ISBN 978 0 580 78780 5

ICS 59.140.30

**Compliance with a British Standard cannot confer immunity from legal obligations.**

This British Standard was published under the authority of the Standards Policy and Strategy Committee on 30 September 2015.

**Amendments/corrigenda issued since publication**

Date	Text affected
------	---------------

---

EUROPEAN STANDARD

**EN ISO 3380**

NORME EUROPÉENNE

EUROPÄISCHE NORM

September 2015

ICS 59.140.30

Supersedes EN ISO 3380:2002

English Version

## Leather - Physical and mechanical tests - Determination of shrinkage temperature up to 100 °C (ISO 3380:2015)

Cuir - Essais physiques et mécaniques - Détermination de la température de rétrécissement jusqu'à 100 °C (ISO 3380:2015)

Leder - Physikalische und mechanische Prüfungen - Bestimmung der Schrumpfungstemperatur bis 100 °C (ISO 3380:2015)

This European Standard was approved by CEN on 8 August 2015.

CEN members are bound to comply with the CEN/CENELEC Internal Regulations which stipulate the conditions for giving this European Standard the status of a national standard without any alteration. Up-to-date lists and bibliographical references concerning such national standards may be obtained on application to the CEN-CENELEC Management Centre or to any CEN member.

This European Standard exists in three official versions (English, French, German). A version in any other language made by translation under the responsibility of a CEN member into its own language and notified to the CEN-CENELEC Management Centre has the same status as the official versions.

CEN members are the national standards bodies of Austria, Belgium, Bulgaria, Croatia, Cyprus, Czech Republic, Denmark, Estonia, Finland, Former Yugoslav Republic of Macedonia, France, Germany, Greece, Hungary, Iceland, Ireland, Italy, Latvia, Lithuania, Luxembourg, Malta, Netherlands, Norway, Poland, Portugal, Romania, Slovakia, Slovenia, Spain, Sweden, Switzerland, Turkey and United Kingdom.



EUROPEAN COMMITTEE FOR STANDARDIZATION  
COMITÉ EUROPÉEN DE NORMALISATION  
EUROPÄISCHES KOMITEE FÜR NORMUNG

**CEN-CENELEC Management Centre: Avenue Marnix 17, B-1000 Brussels**

## European foreword

This document (EN ISO 3380:2015) has been prepared by Technical Committee CEN/TC 289 “Leather”, the secretariat of which is held by UNI, in collaboration with Technical Committee IULTCS “International Union of Leather Technologists and Chemists Societies”.

This European Standard shall be given the status of a national standard, either by publication of an identical text or by endorsement, at the latest by March 2016, and conflicting national standards shall be withdrawn at the latest by March 2016.

This document supersedes EN ISO 3380:2002.

Attention is drawn to the possibility that some of the elements of this document may be the subject of patent rights. CEN [and/or CENELEC] shall not be held responsible for identifying any or all such patent rights.

According to the CEN-CENELEC Internal Regulations, the national standards organizations of the following countries are bound to implement this European Standard: Austria, Belgium, Bulgaria, Croatia, Cyprus, Czech Republic, Denmark, Estonia, Finland, Former Yugoslav Republic of Macedonia, France, Germany, Greece, Hungary, Iceland, Ireland, Italy, Latvia, Lithuania, Luxembourg, Malta, Netherlands, Norway, Poland, Portugal, Romania, Slovakia, Slovenia, Spain, Sweden, Switzerland, Turkey and the United Kingdom.

### Endorsement notice

The text of ISO 3380:2015 has been approved by CEN as EN ISO 3380:2015 without any modification.

# Contents

	Page
Foreword .....	iv
<b>1 Scope .....</b>	<b>1</b>
<b>2 Normative references .....</b>	<b>1</b>
<b>3 Principle .....</b>	<b>1</b>
<b>4 Apparatus .....</b>	<b>1</b>
<b>5 Sampling and sample preparation .....</b>	<b>2</b>
<b>6 Procedure .....</b>	<b>3</b>
<b>7 Test report .....</b>	<b>3</b>
<b>Annex A (informative) Sources of test apparatus .....</b>	<b>4</b>

## Foreword

ISO (the International Organization for Standardization) is a worldwide federation of national standards bodies (ISO member bodies). The work of preparing International Standards is normally carried out through ISO technical committees. Each member body interested in a subject for which a technical committee has been established has the right to be represented on that committee. International organizations, governmental and non-governmental, in liaison with ISO, also take part in the work. ISO collaborates closely with the International Electrotechnical Commission (IEC) on all matters of electrotechnical standardization.

The procedures used to develop this document and those intended for its further maintenance are described in the ISO/IEC Directives, Part 1. In particular the different approval criteria needed for the different types of ISO documents should be noted. This document was drafted in accordance with the editorial rules of the ISO/IEC Directives, Part 2 ([www.iso.org/directives](http://www.iso.org/directives)).

Attention is drawn to the possibility that some of the elements of this document may be the subject of patent rights. ISO shall not be held responsible for identifying any or all such patent rights. Details of any patent rights identified during the development of the document will be in the Introduction and/or on the ISO list of patent declarations received (see [www.iso.org/patents](http://www.iso.org/patents)).

Any trade name used in this document is information given for the convenience of users and does not constitute an endorsement.

For an explanation on the meaning of ISO specific terms and expressions related to conformity assessment, as well as information about ISO's adherence to the WTO principles in the Technical Barriers to Trade (TBT) see the following URL: [Foreword - Supplementary information](#).

ISO 3380 was prepared by the Physical Test Commission of the International Union of Leather Technologists and Chemists Societies (IUP Commission, IULTCS) in collaboration with the European Committee for Standardization (CEN) Technical Committee CEN/TC 289, *Leather*, the secretariat of which is held by UNI, in accordance with the Agreement on technical cooperation between ISO and CEN (Vienna Agreement). It is based on IUP 16 originally published in J. Soc. Leather Trades Chemists 47, p. 122, (1963) and an updated version published in J. Soc. Leather Tech. Chem. 84, p. 359, (2000).

IULTCS, originally formed in 1897, is a world-wide organization of professional leather societies to further the advancement of leather science and technology. IULTCS has three Commissions, which are responsible for establishing international methods for the sampling and testing of leather. ISO recognizes IULTCS as an international standardizing body for the preparation of test methods for leather.

This third edition cancels and replaces the second edition (ISO 3380:2002), [6.5](#) of which has been technically revised.

# Leather — Physical and mechanical tests — Determination of shrinkage temperature up to 100 °C

## 1 Scope

This International Standard specifies a method for determination of the shrinkage temperature of leather up to 100 °C. It is applicable to all leathers.

## 2 Normative references

The following documents, in whole or in part, are normatively referenced in this document and are indispensable for its application. For dated references, only the edition cited applies. For undated references, the latest edition of the referenced document (including any amendments) applies.

ISO 2418, *Leather — Chemical, physical and mechanical and fastness tests — Sampling location*

ISO 2589, *Leather — Physical and mechanical tests — Determination of thickness*

ISO 3696, *Water for analytical laboratory use — Specification and test methods*

## 3 Principle

The test piece is heated at a specified rate in water until a sudden shrinkage occurs.

## 4 Apparatus

**4.1** Schematic layout of a suitable instrument is shown in [Figure 1](#). The instrument should include the following parts.

**4.1.1 Vessel**, minimum volume of 500 ml and minimum working depth of 110 mm. The vessel may be pressurized to operate at temperatures in excess of 100 °C.

**4.1.2 Fixed test piece holder**, for example, a pin or clip, 30 mm ± 5 mm above the base of the vessel.

**4.1.3 Moveable test piece holder**, for example, a hook or clip. One end is attached to the top of the test piece. The other end is attached to a thread which passes over a pulley and terminates in a mass 3 g heavier than the moveable holder.

**4.1.4 Pointer**, with means of monitoring its movement. In the instrument shown, the relative dimensions of the pulley and pointer shall be such that any movement of the moveable holder ([4.1.3](#)) is magnified by a factor of at least five.

**4.1.5 Temperature measuring device**, graduated to 1 °C and shown to be accurate to ±0,5 °C with the sensor placed close to the centre of the test piece and a working range suitable for the sample under test.

**4.1.6 Distilled or de-ionized water**, conforming to the requirements grade 3 of ISO 3696.

**4.1.7 Heater**, capable of heating the vessel filled to its working depth with distilled or de-ionized water at a rate of 2 °C/min ± 0,2 °C/min.

**4.1.8 Stirrer**, capable of sufficiently agitating the water in the vessel such that the temperatures at the top and bottom of the test piece do not differ by more than 1 °C.

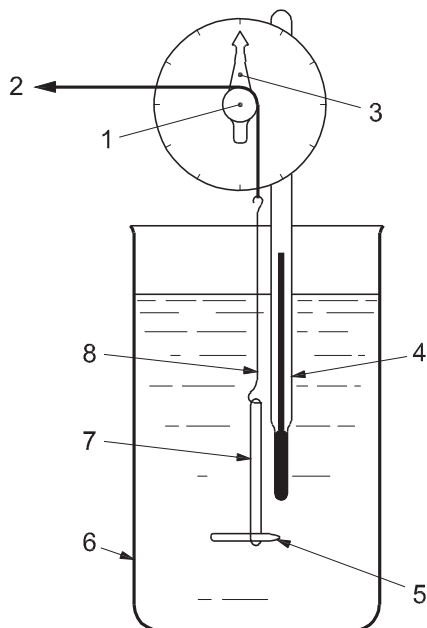

**Key**

- |   |  |   |                           |
|---|--|---|---------------------------|
| 1 | pulley   | 5 | fixed test piece holder   |
| 2 | 3 g force  | 6 | vessel                    |
| 3 | pointer  | 7 | test piece                |
| 4 | temperature measuring device (thermometer shown) | 8 | movable test piece holder |

**Figure 1 — Shrinkage temperature apparatus (schematic)**

**4.2 Thickness gauge**, conforming to the requirements of ISO 2589.

**4.3 Desiccator** or other vessel which can be evacuated.

**4.4 Vacuum pump**, capable of reducing the absolute pressure in the desiccator to less than 4 kPa within 2 min.

**4.5 Glass test tube**, with internal diameter of  $10 \text{ mm} \pm 2 \text{ mm}$  and minimum height of 100 mm.

## 5 Sampling and sample preparation

**5.1** Sample in accordance with ISO 2418.

**5.2** Determine the thickness of the sample in accordance with ISO 2589.

**5.3** Cut rectangular test pieces  $50 \text{ mm} \pm 2 \text{ mm} \times 3,0 \text{ mm} \pm 0,2 \text{ mm}$  if the thickness of the sample is 3 mm or less. If the thickness is greater than 3 mm, cut rectangular test pieces  $50 \text{ mm} \pm 2 \text{ mm} \times 2,0 \text{ mm} \pm 0,2 \text{ mm}$ . Prepare two samples parallel to the backbone and two samples perpendicular to the backbone.

**NOTE 1** If there is a requirement for more than two hides or skins to be tested in one batch, then only one sample in each direction needs to be taken from each hide or skin, provided that the overall total is not less than four test pieces in each direction.



NOTE 2 There is no requirement to condition the sample for this test or to carry out the test under standard conditions.

NOTE 3 Other dimensions are used if it is shown that they do not affect the results.

## 6 Procedure

For dry test samples, carry out [6.1](#) to [6.3](#). For wet test samples, omit [6.1](#) to [6.3](#).

**6.1** Put 5,5 ml ± 0,5 ml distilled or de-ionized water into the glass tube ([4.5](#)) and immerse the test piece in it, using a glass rod to keep in immersed, if necessary.

**6.2** Stand the tube in the desiccator ([4.3](#)), supporting it in an upright position, if necessary. Evacuate the desiccator and maintain the absolute pressure in it below 4 kPa for 1 min to 2 min.

**6.3** Allow air to enter the desiccator and keep the test piece immersed for a minimum of 1 h and a maximum of 6 h.

**6.4** Attach an end of the test piece to the fixed test piece holder ([4.1.2](#)) and the other end to the moveable holder ([4.1.3](#)). Adjust the thread, pulley, and mass so that the test piece is held under the tension of the mass.

**6.5** Place sufficient distilled or de-ionized water of (20 ± 2) °C into the vessel ([4.1.1](#)) to give a depth of at least 30 mm over the top of the test piece. If the shrinkage temperature of the test piece is known, then use water with a temperature at least 10 °C below the expected shrinkage temperature. In such a case, it is essential to allow 5 min for a temperature adjustment of the leather sample.

**6.6** Heat the water and maintain the rate of temperature rise at 2 °C/min ± 0,2 °C/min.

**6.7** At 30 s intervals, note the temperature and the corresponding position of the pointer. Continue the observation until the test piece shrinks considerably (see [6.8](#)), the water boils vigorously, or the desired temperature is reached. If the water boils, record the temperature.

**6.8** Inspect the results or plot pointer position against temperature to find the temperature corresponding to the movement of the pointer which is equivalent to a shrinkage of the test piece of 0,3 % from its maximum length. Record the temperature as the shrinkage temperature.

**6.9** If the shrinkage temperature determined in [6.8](#) is not at least 5 °C higher than the temperature of the water originally placed in the vessel, discard the result and repeat [6.1](#) to [6.8](#) using water at a lower initial temperature.

## 7 Test report

The test report shall include the following:

- a) reference to this International Standard, i.e. ISO 3380;
- b) mean shrinkage temperature in each direction as obtained in [6.8](#) or quoted as greater than the final temperature reached in [6.7](#);
- c) any deviations from the method specified in this International Standard;
- d) full details for identification of the sample and any deviations from ISO 2418 with respect to sampling.

## **Annex A** **(informative)**

### **Sources of test apparatus**

Examples of suitable products available commercially are given below. This information is given for the convenience of users of this International Standard and does not constitute an endorsement by ISO of these products.

The apparatus is manufactured, for example, by the following:

- SATRA Technology Centre, Wyndham Way, Telford Way, Kettering, Northamptonshire NN16 8SD, England;
- Giuliani Apparecchi Scientifici, via Centrallo, 68/18, I-1056 Torino, Italy;
- SODEMAT, 29 rue Jean Moulin, ZA Coulmet, F-10450 Breviandes, France;
- Muver - Francisco Muñoz Irlles, Avda Hispanoamerica 42, E-03610 Petrer (Alicante), Spain.







# British Standards Institution (BSI)

BSI is the national body responsible for preparing British Standards and other standards-related publications, information and services.

BSI is incorporated by Royal Charter. British Standards and other standardization products are published by BSI Standards Limited.

## About us

We bring together business, industry, government, consumers, innovators and others to shape their combined experience and expertise into standards-based solutions.

The knowledge embodied in our standards has been carefully assembled in a dependable format and refined through our open consultation process. Organizations of all sizes and across all sectors choose standards to help them achieve their goals.

## Information on standards

We can provide you with the knowledge that your organization needs to succeed. Find out more about British Standards by visiting our website at [bsigroup.com/standards](http://bsigroup.com/standards) or contacting our Customer Services team or Knowledge Centre.

## Buying standards

You can buy and download PDF versions of BSI publications, including British and adopted European and international standards, through our website at [bsigroup.com/shop](http://bsigroup.com/shop), where hard copies can also be purchased.

If you need international and foreign standards from other Standards Development Organizations, hard copies can be ordered from our Customer Services team.

## Subscriptions

Our range of subscription services are designed to make using standards easier for you. For further information on our subscription products go to [bsigroup.com/subscriptions](http://bsigroup.com/subscriptions).

With **British Standards Online (BSOL)** you'll have instant access to over 55,000 British and adopted European and international standards from your desktop. It's available 24/7 and is refreshed daily so you'll always be up to date.

You can keep in touch with standards developments and receive substantial discounts on the purchase price of standards, both in single copy and subscription format, by becoming a **BSI Subscribing Member**.

**PLUS** is an updating service exclusive to BSI Subscribing Members. You will automatically receive the latest hard copy of your standards when they're revised or replaced.

To find out more about becoming a BSI Subscribing Member and the benefits of membership, please visit [bsigroup.com/shop](http://bsigroup.com/shop).

With a **Multi-User Network Licence (MUNL)** you are able to host standards publications on your intranet. Licences can cover as few or as many users as you wish. With updates supplied as soon as they're available, you can be sure your documentation is current. For further information, email [bsmusales@bsigroup.com](mailto:bsmusales@bsigroup.com).

## BSI Group Headquarters

389 Chiswick High Road London W4 4AL UK

## Revisions

Our British Standards and other publications are updated by amendment or revision.

We continually improve the quality of our products and services to benefit your business. If you find an inaccuracy or ambiguity within a British Standard or other BSI publication please inform the Knowledge Centre.

## Copyright

All the data, software and documentation set out in all British Standards and other BSI publications are the property of and copyrighted by BSI, or some person or entity that owns copyright in the information used (such as the international standardization bodies) and has formally licensed such information to BSI for commercial publication and use. Except as permitted under the Copyright, Designs and Patents Act 1988 no extract may be reproduced, stored in a retrieval system or transmitted in any form or by any means – electronic, photocopying, recording or otherwise – without prior written permission from BSI. Details and advice can be obtained from the Copyright & Licensing Department.

## Useful Contacts:

### Customer Services

**Tel:** +44 845 086 9001

**Email (orders):** [orders@bsigroup.com](mailto:orders@bsigroup.com)

**Email (enquiries):** [cservices@bsigroup.com](mailto:cservices@bsigroup.com)

### Subscriptions

**Tel:** +44 845 086 9001

**Email:** [subscriptions@bsigroup.com](mailto:subscriptions@bsigroup.com)

### Knowledge Centre

**Tel:** +44 20 8996 7004

**Email:** [knowledgecentre@bsigroup.com](mailto:knowledgecentre@bsigroup.com)

### Copyright & Licensing

**Tel:** +44 20 8996 7070

**Email:** [copyright@bsigroup.com](mailto:copyright@bsigroup.com)



...making excellence a habit.™