

BS EN ISO 3379:2015



BSI Standards Publication

# Leather — Determination of distension and strength of surface (Ball burst method)

**bsi.**

...making excellence a habit.™

### **National foreword**

This British Standard is the UK implementation of EN ISO 3379:2015.

The UK participation in its preparation was entrusted to Technical Committee TCI/69, Footwear, leather and coated fabrics.

A list of organizations represented on this committee can be obtained on request to its secretary.

This publication does not purport to include all the necessary provisions of a contract. Users are responsible for its correct application.

© The British Standards Institution 2015.  
Published by BSI Standards Limited 2015

ISBN 978 0 580 83032 7

ICS 59.140.30

**Compliance with a British Standard cannot confer immunity from legal obligations.**

This British Standard was published under the authority of the Standards Policy and Strategy Committee on 30 September 2015.

### **Amendments/corrigenda issued since publication**

Date	Text affected
------	---------------

---

EUROPEAN STANDARD

**EN ISO 3379**

NORME EUROPÉENNE

EUROPÄISCHE NORM

September 2015

---

ICS 59.140.30

English Version

## Leather - Determination of distension and strength of surface (Ball burst method) (ISO 3379:2015)

Cuir - Détermination de l'extension et de la résistance à la traction de la surface (méthode de la bille) (ISO 3379:2015)

Leder - Bestimmung der Narbendehnfähigkeit und -bruchkraft (Lastometer-Methode) (ISO 3379:2015)

This European Standard was approved by CEN on 8 August 2015.

CEN members are bound to comply with the CEN/CENELEC Internal Regulations which stipulate the conditions for giving this European Standard the status of a national standard without any alteration. Up-to-date lists and bibliographical references concerning such national standards may be obtained on application to the CEN-CENELEC Management Centre or to any CEN member.

This European Standard exists in three official versions (English, French, German). A version in any other language made by translation under the responsibility of a CEN member into its own language and notified to the CEN-CENELEC Management Centre has the same status as the official versions.

CEN members are the national standards bodies of Austria, Belgium, Bulgaria, Croatia, Cyprus, Czech Republic, Denmark, Estonia, Finland, Former Yugoslav Republic of Macedonia, France, Germany, Greece, Hungary, Iceland, Ireland, Italy, Latvia, Lithuania, Luxembourg, Malta, Netherlands, Norway, Poland, Portugal, Romania, Slovakia, Slovenia, Spain, Sweden, Switzerland, Turkey and United Kingdom.



EUROPEAN COMMITTEE FOR STANDARDIZATION  
COMITÉ EUROPÉEN DE NORMALISATION  
EUROPÄISCHES KOMITEE FÜR NORMUNG

**CEN-CENELEC Management Centre: Avenue Marnix 17, B-1000 Brussels**

## European foreword

This document (EN ISO 3379:2015) has been prepared by Technical Committee CEN/TC 289 “Leather”, the secretariat of which is held by UNI, in collaboration with Technical Committee IULTCS “International Union of Leather Technologists and Chemists Societies”.

This European Standard shall be given the status of a national standard, either by publication of an identical text or by endorsement, at the latest by March 2016, and conflicting national standards shall be withdrawn at the latest by March 2016.

Attention is drawn to the possibility that some of the elements of this document may be the subject of patent rights. CEN [and/or CENELEC] shall not be held responsible for identifying any or all such patent rights.

According to the CEN-CENELEC Internal Regulations, the national standards organizations of the following countries are bound to implement this European Standard: Austria, Belgium, Bulgaria, Croatia, Cyprus, Czech Republic, Denmark, Estonia, Finland, Former Yugoslav Republic of Macedonia, France, Germany, Greece, Hungary, Iceland, Ireland, Italy, Latvia, Lithuania, Luxembourg, Malta, Netherlands, Norway, Poland, Portugal, Romania, Slovakia, Slovenia, Spain, Sweden, Switzerland, Turkey and the United Kingdom.

### Endorsement notice

The text of ISO 3379:2015 has been approved by CEN as EN ISO 3379:2015 without any modification.

# Contents

	Page
Foreword .....	iv
<b>1 Scope .....</b>	<b>1</b>
<b>2 Normative references .....</b>	<b>1</b>
<b>3 Terms and definitions .....</b>	<b>1</b>
<b>4 Principle .....</b>	<b>1</b>
<b>5 Apparatus and material .....</b>	<b>2</b>
<b>6 Sampling and sample preparation .....</b>	<b>3</b>
<b>7 Procedure .....</b>	<b>3</b>
<b>8 Test report .....</b>	<b>4</b>
<b>Annex A (informative) Sources of apparatus .....</b>	<b>5</b>

## Foreword

ISO (the International Organization for Standardization) is a worldwide federation of national standards bodies (ISO member bodies). The work of preparing International Standards is normally carried out through ISO technical committees. Each member body interested in a subject for which a technical committee has been established has the right to be represented on that committee. International organizations, governmental and non-governmental, in liaison with ISO, also take part in the work. ISO collaborates closely with the International Electrotechnical Commission (IEC) on all matters of electrotechnical standardization.

The procedures used to develop this document and those intended for its further maintenance are described in the ISO/IEC Directives, Part 1. In particular the different approval criteria needed for the different types of ISO documents should be noted. This document was drafted in accordance with the editorial rules of the ISO/IEC Directives, Part 2 ([www.iso.org/directives](http://www.iso.org/directives)).

Attention is drawn to the possibility that some of the elements of this document may be the subject of patent rights. ISO shall not be held responsible for identifying any or all such patent rights. Details of any patent rights identified during the development of the document will be in the Introduction and/or on the ISO list of patent declarations received (see [www.iso.org/patents](http://www.iso.org/patents)).

Any trade name used in this document is information given for the convenience of users and does not constitute an endorsement.

For an explanation on the meaning of ISO specific terms and expressions related to conformity assessment, as well as information about ISO's adherence to the WTO principles in the Technical Barriers to Trade (TBT) see the following URL: [Foreword - Supplementary information](#).

ISO 3379 was prepared by the Physical Test Commission of the International Union of Leather Technologists and Chemists Societies (IUP Commission, IULTCS) in collaboration with the European Committee for Standardization (CEN) Technical Committee CEN/TC 289, *Leather*, the secretariat of which is held by UNI, in accordance with the Agreement on technical cooperation between ISO and CEN (Vienna Agreement).

IULTCS, originally formed in 1897, is a world-wide organization of professional leather societies to further the advancement of leather science and technology. IULTCS has three Commissions, which are responsible for establishing international methods for the sampling and testing of leather. ISO recognizes IULTCS as an international standardizing body for the preparation of test methods for leather.

This second edition cancels and replaces the first edition (ISO 3379:1976), which has been technically revised.

# Leather — Determination of distension and strength of surface (Ball burst method)

## 1 Scope

This International Standard specifies a test method for the determination of distension and strength of the leather grain or finished surface. This method is applicable to all flexible leathers and it is particularly suitable to determine the lastability of leathers for footwear uppers.

## 2 Normative references

The following documents, in whole or in part, are normatively referenced in this document and are indispensable for its application. For dated references, only the edition cited applies. For undated references, the latest edition of the referenced document (including any amendments) applies.

ISO 2418, *Leather — Chemical, physical and mechanical and fastness tests — Sampling location*

ISO 2419, *Leather — Physical and mechanical tests — Sample preparation and conditioning*

ISO 2589, *Leather — Physical and mechanical tests — Determination of thickness*

## 3 Terms and definitions

For the purposes of this document, the following terms and definitions apply.

### 3.1

#### **wearing surface**

exposed or visible face of the leather when used in its intended application

Note 1 to entry: The wearing surface is usually the grain side of leather, however, the wearing surface of some leathers may be otherwise dressed or finished, e.g. patent leather.

### 3.2

#### **reverse side**

opposite side to the wearing surface

Note 1 to entry: The reverse side is usually the flesh side of leather.

### 3.3

#### **cracking**

small surface splits or tears less than approximately 0,5 mm

### 3.4

#### **bursting**

complete rupture of the full thickness of the test piece

## 4 Principle

A circular test piece is clamped around its edge and is gradually distended by forcing a steel metal ball, attached to the end of a plunger, against the centre of the test piece on the reverse side. At certain distension, measured in terms of distance travelled by the plunger, cracks appear on the wearing surface of the test piece or it sustains other permanent physical damage; this distension is recorded as the cracking point or first damage. At a higher distension, the material usually bursts and this distension may also be recorded.

## 5 Apparatus and material

5.1 **Test machine**, incorporating the following (see [Figure 1](#)).

5.1.1 **Clamp**, for holding securely the test piece around its edge, leaving a central circular aperture of diameter  $25,0 \text{ mm} \pm 0,5 \text{ mm}$ . The design of the clamping system of the machine shall ensure that the test piece does not slip during the test and shall neither stretch nor compress the central area of the test piece as it is clamped.

NOTE To ensure that the test piece does not slip in the clamp during the test, it might be necessary to add some interlocking profile, serrations, or other mechanical intervention to the face of the top and bottom clamps.

5.1.2 **Moveable plunger**, with a hemispherical end, nominal diameter  $6,25 \text{ mm} \pm 0,05 \text{ mm}$ .

5.1.3 **Means of moving the plunger**, without rotation, against the centre of the test piece and in a direction normal to the plane occupied by the test piece when it is clamped, at a speed of  $0,20 \text{ mm/s} \pm 0,05 \text{ mm/s}$ .

5.1.4 **Means of monitoring and recording distension** of the leather, or travel of the plunger from zero, in a direction normal to the plane occupied by the test piece with an accuracy of  $\pm 0,05 \text{ mm}$ .

5.1.5 **Means of monitoring and recording the force** on the plunger with an accuracy of  $\pm 10 \text{ N}$ .

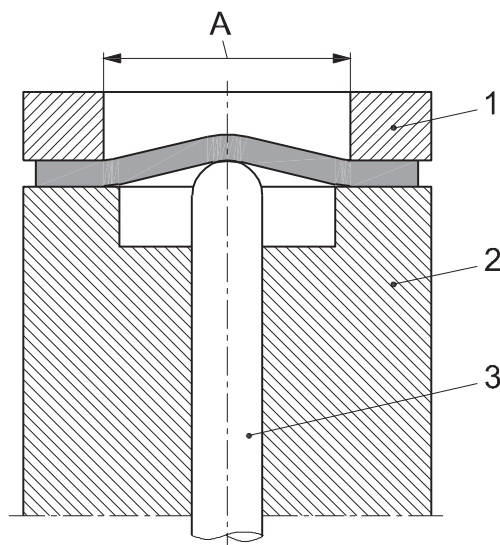

### Key

- 1 top clamp
- 2 bottom clamp
- 3 plunger with hemispherical end
- A aperture diameter (25,0 mm)

**Figure 1 — Clamp and plunger**

5.2 **Press knife**, as specified in ISO 2419, capable of cutting a circular test piece in one operation with suitable dimensions to be firmly clamped in the test machine.

5.3 **Thickness gauge**, as specified in ISO 2589.



## 6 Sampling and sample preparation

6.1 Condition the leather sample in accordance with ISO 2419.

6.2 Sample in accordance with ISO 2418. Using the press knife (5.2), cut at least three test pieces in accordance with ISO 2419.

NOTE If there is a requirement for more than two hides or skins to be tested in one batch, then only one test piece needs to be taken from each hide or skin, provided that the overall total is not less than three test pieces.

6.3 Measure the thickness of the test pieces in accordance with ISO 2589.

## 7 Procedure

7.1 Ensure that the test machine is set with the central plunger retracted to zero or minimum distension. If it has a maximum force indicator, set it to zero.

NOTE “Zero” distension is set by placing a circular, rigid, and flat material in the apparatus in place of the test piece.

7.2 Clamp the conditioned test piece into the test machine so that the ball-ended plunger acts on the reverse side of the test piece and the test piece is flat.

7.3 Increase the distension at a rate of  $0,20 \text{ mm/s} \pm 0,05 \text{ mm/s}$  and watch the grain or finished surface for the occurrence of a crack or first damage on the surface.

7.4 When a crack or first damage occurs, record the distension in millimetre to the nearest 0,1 mm and the force in newton to the nearest 10 N. If burst is required, continue the distension with the minimum of delay.

Patent leather is a special case because often, the grain of the leather cracks before the patent surface film. Particular care is therefore required when observing patent leather test pieces. Two indications of the grain cracking are a small shallow depression in the surface of the film above the crack and a momentary drop in the force on the plunger. If the patent film cracks, this shall also be regarded as a “grain crack” whether or not a crack in the grain is visible.

NOTE For some leathers, it is possible to determine grain or finish cracking of the wearing surface by analysing the force-displacement curve. When cracking occurs, there is a sudden decrease in the load, to be considered only as a confirmation of the visual assessment.

7.5 If the test piece does not crack before bursting, report the values of distension and load at burst.

If the test piece does not burst when the maximum force or distension is reached, record the displacement and report the result as “more than maximum distension” or “more than maximum load” (e.g.  $>15 \text{ mm}$  or  $>800 \text{ N}$ ).

NOTE If there is a pause during the distension of a test piece, relaxation of stresses in it occurs and the force reading tends to fall. Therefore, the test is ideally continuous with no delays, but, if necessary, any delay during distension between cracking and burst is less than 15 s.

7.6 Retract the plunger, remove the test specimen, and inspect the marks left by the clamps on the wearing surface of the specimen. If there are signs of slippage having occurred during the test, for example, evident by blurring of clamping rings or of tearing of the clamped edges, reject the results and repeat the procedure 7.1 to 7.6 with a new specimen.

7.7 Repeat 7.1 to 7.6 for other test pieces.

## 8 Test report

The test report shall include the following:

- a) reference to this International Standard, i.e. ISO 3379;
- b) full details for identification of the sample, including any specific reference if known, and the thickness of the leather in millimetre (mm);
- c) mean distension at crack in millimetre (mm) to the nearest 0,1 mm; if the test piece does not crack before bursting, report the values of distension at burst;
- d) mean force at crack in newton (N) to the nearest 10 N; if the test piece does not crack before bursting, report the values of load at burst;
- e) mean distension at burst in millimetre (mm) to the nearest 0,1 mm, if required;
- f) mean force at burst in newton (N) to the nearest 10 N, if required;
- g) standard atmosphere used for conditioning and testing, as given in ISO 2419;
- h) any deviations from the method specified in this International Standard.

## Annex A (informative)

### Sources of apparatus

Examples of sources of suitable apparatus available commercially are given below. This information is given for the convenience of users of this International Standard and does not constitute an endorsement by ISO or CEN of these products:

- SATRA Technology Centre, Wyndham Way, Telford Way, Kettering, Northants, NN16 8SD England, [www.satra.co.uk](http://www.satra.co.uk)
- Giuliani Apparecchi Scientifici, via Centrallo, 68/18, I-10156 Torino, Italy, [www.giuliani.it](http://www.giuliani.it)
- Muver - Francisco Muñoz Irlas, Avda Hispanoamerica 42, E-03610 Petrer (Alicante), Spain, [www.muver.com](http://www.muver.com)
- SODEMAT, 29 rue Jean Moulin, ZA Coulmet, F-10450 Breviandes, France
- ZIPOR - Equipamentos e Tecnologia Industrial, S.A. - Rua dos Açores, 278 - Zona Industrial nº 1 - 3700-018 S. João da Madeira - Portugal, [www.vipor.com](http://www.vipor.com)
- PFI, Test and Research Institute, Marie-Curie-Straße 19, D-66953 Pirmasens, Germany, [www.pfi-germany.de](http://www.pfi-germany.de)





# British Standards Institution (BSI)

BSI is the national body responsible for preparing British Standards and other standards-related publications, information and services.

BSI is incorporated by Royal Charter. British Standards and other standardization products are published by BSI Standards Limited.

## About us

We bring together business, industry, government, consumers, innovators and others to shape their combined experience and expertise into standards-based solutions.

The knowledge embodied in our standards has been carefully assembled in a dependable format and refined through our open consultation process. Organizations of all sizes and across all sectors choose standards to help them achieve their goals.

## Information on standards

We can provide you with the knowledge that your organization needs to succeed. Find out more about British Standards by visiting our website at [bsigroup.com/standards](http://bsigroup.com/standards) or contacting our Customer Services team or Knowledge Centre.

## Buying standards

You can buy and download PDF versions of BSI publications, including British and adopted European and international standards, through our website at [bsigroup.com/shop](http://bsigroup.com/shop), where hard copies can also be purchased.

If you need international and foreign standards from other Standards Development Organizations, hard copies can be ordered from our Customer Services team.

## Subscriptions

Our range of subscription services are designed to make using standards easier for you. For further information on our subscription products go to [bsigroup.com/subscriptions](http://bsigroup.com/subscriptions).

With **British Standards Online (BSOL)** you'll have instant access to over 55,000 British and adopted European and international standards from your desktop. It's available 24/7 and is refreshed daily so you'll always be up to date.

You can keep in touch with standards developments and receive substantial discounts on the purchase price of standards, both in single copy and subscription format, by becoming a **BSI Subscribing Member**.

**PLUS** is an updating service exclusive to BSI Subscribing Members. You will automatically receive the latest hard copy of your standards when they're revised or replaced.

To find out more about becoming a BSI Subscribing Member and the benefits of membership, please visit [bsigroup.com/shop](http://bsigroup.com/shop).

With a **Multi-User Network Licence (MUNL)** you are able to host standards publications on your intranet. Licences can cover as few or as many users as you wish. With updates supplied as soon as they're available, you can be sure your documentation is current. For further information, email [bsmusales@bsigroup.com](mailto:bsmusales@bsigroup.com).

## BSI Group Headquarters

389 Chiswick High Road London W4 4AL UK

## Revisions

Our British Standards and other publications are updated by amendment or revision.

We continually improve the quality of our products and services to benefit your business. If you find an inaccuracy or ambiguity within a British Standard or other BSI publication please inform the Knowledge Centre.

## Copyright

All the data, software and documentation set out in all British Standards and other BSI publications are the property of and copyrighted by BSI, or some person or entity that owns copyright in the information used (such as the international standardization bodies) and has formally licensed such information to BSI for commercial publication and use. Except as permitted under the Copyright, Designs and Patents Act 1988 no extract may be reproduced, stored in a retrieval system or transmitted in any form or by any means – electronic, photocopying, recording or otherwise – without prior written permission from BSI. Details and advice can be obtained from the Copyright & Licensing Department.

## Useful Contacts:

### Customer Services

**Tel:** +44 845 086 9001

**Email (orders):** [orders@bsigroup.com](mailto:orders@bsigroup.com)

**Email (enquiries):** [cservices@bsigroup.com](mailto:cservices@bsigroup.com)

### Subscriptions

**Tel:** +44 845 086 9001

**Email:** [subscriptions@bsigroup.com](mailto:subscriptions@bsigroup.com)

### Knowledge Centre

**Tel:** +44 20 8996 7004

**Email:** [knowledgecentre@bsigroup.com](mailto:knowledgecentre@bsigroup.com)

### Copyright & Licensing

**Tel:** +44 20 8996 7070

**Email:** [copyright@bsigroup.com](mailto:copyright@bsigroup.com)



...making excellence a habit.™