

BS EN ISO 2811-2:2011



BSI Standards Publication

Paints and varnishes — Determination of density

Part 2: Immersed body (plummet) method
(ISO 2811-2:2011)

bsi.

...making excellence a habit.™

National foreword

This British Standard is the UK implementation of EN ISO 2811-2:2011. It supersedes BS EN ISO 2811-2:2001 which is withdrawn.

The UK participation in its preparation was entrusted to Technical Committee STI/10, Test methods for paints.

A list of organizations represented on this committee can be obtained on request to its secretary.

This publication does not purport to include all the necessary provisions of a contract. Users are responsible for its correct application.

© BSI 2011

ISBN 978 0 580 66281 2

ICS 87.040

Compliance with a British Standard cannot confer immunity from legal obligations.

This British Standard was published under the authority of the Standards Policy and Strategy Committee on 31 March 2011.

Amendments issued since publication

Date	Text affected
------	---------------

English Version

**Paints and varnishes - Determination of density - Part 2:
Immersed body (plummet) method (ISO 2811-2:2011)**

Peintures et vernis - Détermination de la masse volumique
- Partie 2: Méthode par immersion d'un corps (plongeur)
(ISO 2811-2:2011)

Beschichtungsstoffe - Bestimmung der Dichte - Teil 2:
Tauchkörper-Verfahren (ISO 2811-2:2011)

This European Standard was approved by CEN on 19 February 2011.

CEN members are bound to comply with the CEN/CENELEC Internal Regulations which stipulate the conditions for giving this European Standard the status of a national standard without any alteration. Up-to-date lists and bibliographical references concerning such national standards may be obtained on application to the CEN-CENELEC Management Centre or to any CEN member.

This European Standard exists in three official versions (English, French, German). A version in any other language made by translation under the responsibility of a CEN member into its own language and notified to the CEN-CENELEC Management Centre has the same status as the official versions.

CEN members are the national standards bodies of Austria, Belgium, Bulgaria, Croatia, Cyprus, Czech Republic, Denmark, Estonia, Finland, France, Germany, Greece, Hungary, Iceland, Ireland, Italy, Latvia, Lithuania, Luxembourg, Malta, Netherlands, Norway, Poland, Portugal, Romania, Slovakia, Slovenia, Spain, Sweden, Switzerland and United Kingdom.



EUROPEAN COMMITTEE FOR STANDARDIZATION
COMITÉ EUROPÉEN DE NORMALISATION
EUROPÄISCHES KOMITEE FÜR NORMUNG

Management Centre: Avenue Marnix 17, B-1000 Brussels

Foreword

This document (EN ISO 2811-2:2011) has been prepared by Technical Committee ISO/TC 35 "Paints and varnishes" in collaboration with Technical Committee CEN/TC 139 "Paints and varnishes" the secretariat of which is held by DIN.

This European Standard shall be given the status of a national standard, either by publication of an identical text or by endorsement, at the latest by September 2011, and conflicting national standards shall be withdrawn at the latest by September 2011.

Attention is drawn to the possibility that some of the elements of this document may be the subject of patent rights. CEN [and/or CENELEC] shall not be held responsible for identifying any or all such patent rights.

This document supersedes EN ISO 2811-2:2001.

According to the CEN/CENELEC Internal Regulations, the national standards organizations of the following countries are bound to implement this European Standard: Austria, Belgium, Bulgaria, Croatia, Cyprus, Czech Republic, Denmark, Estonia, Finland, France, Germany, Greece, Hungary, Iceland, Ireland, Italy, Latvia, Lithuania, Luxembourg, Malta, Netherlands, Norway, Poland, Portugal, Romania, Slovakia, Slovenia, Spain, Sweden, Switzerland and the United Kingdom.

Endorsement notice

The text of ISO 2811-2:2011 has been approved by CEN as a EN ISO 2811-2:2011 without any modification.

Contents

Page

Foreword	iv
1 Scope	1
2 Normative references	1
3 Terms and definitions	1
4 Principle	1
5 Temperature	1
6 Apparatus	2
7 Sampling	3
8 Procedure	3
8.1 General	3
8.2 Determination	3
9 Calculation	4
10 Precision	5
10.1 General	5
10.2 Repeatability limit, r	5
10.3 Reproducibility limit, R	5
11 Test report	5
Annex A (informative) Example of a calibration method	7
Annex B (informative) Temperature variation	8

Foreword

ISO (the International Organization for Standardization) is a worldwide federation of national standards bodies (ISO member bodies). The work of preparing International Standards is normally carried out through ISO technical committees. Each member body interested in a subject for which a technical committee has been established has the right to be represented on that committee. International organizations, governmental and non-governmental, in liaison with ISO, also take part in the work. ISO collaborates closely with the International Electrotechnical Commission (IEC) on all matters of electrotechnical standardization.

International Standards are drafted in accordance with the rules given in the ISO/IEC Directives, Part 2.

The main task of technical committees is to prepare International Standards. Draft International Standards adopted by the technical committees are circulated to the member bodies for voting. Publication as an International Standard requires approval by at least 75 % of the member bodies casting a vote.

Attention is drawn to the possibility that some of the elements of this document may be the subject of patent rights. ISO shall not be held responsible for identifying any or all such patent rights.

ISO 2811-2 was prepared by Technical Committee ISO/TC 35, *Paints and varnishes*, Subcommittee SC 9, *General test methods for paints and varnishes*.

This second edition cancels and replaces the first edition (ISO 2811-2:1997), which has been technically revised.

The main changes are the following.

- a) The unit for the density has been changed from grams per millilitre to grams per cubic centimetre, because this is the more common SI unit.
- b) The determination in duplicate has been changed to a single determination.
- c) The information on calibration procedure has been changed to an example only and the status of Annex B has been changed from normative to informative.
- d) The precision data has been updated by an interlaboratory test.
- e) The normative references have been updated.

ISO 2811 consists of the following parts, under the general title *Paints and varnishes — Determination of density*:

- *Part 1: Pycnometer method*
- *Part 2: Immersed body (plummet) method*
- *Part 3: Oscillation method*
- *Part 4: Pressure cup method*

Paints and varnishes — Determination of density —

Part 2: Immersed body (plummet) method

1 Scope

This part of ISO 2811 specifies a method for determining the density of paints, varnishes and related products, using balls or other round bodies as immersion bodies (plummetts).

The method is limited to materials of low or medium viscosity, and is particularly suitable for production control.

2 Normative references

The following referenced documents are indispensable for the application of this document. For dated references, only the edition cited applies. For undated references, the latest edition of the referenced document (including any amendments) applies.

ISO 1513, *Paints and varnishes — Examination and preparation of test samples*

ISO 15528, *Paints, varnishes and raw materials for paints and varnishes — Sampling*

3 Terms and definitions

For the purposes of this document, the following terms and definitions apply.

3.1 density

ρ
mass divided by the volume of a portion of a material

NOTE It is expressed in grams per cubic centimetre.

4 Principle

The method is based on Archimedes' principle. A container is filled with the product under test and placed on the analytical balance. The plummet is attached to a tripod and is immersed in the product under test. The density is calculated from the balance readings before the plummet is immersed in the material under test and after it is immersed.

5 Temperature

The effect of temperature on density is highly significant with respect to filling properties, and varies with the type of product.

For international reference purposes, it is essential to standardize one test temperature, and $(23,0 \pm 0,5) ^\circ\text{C}$ is specified in this part of ISO 2811. However, it can be more convenient to carry out comparative testing at some other agreed temperature, for example $(20,0 \pm 0,5) ^\circ\text{C}$, as specified by relevant weights and measures legislation (see B.2).

The test sample and plummet shall be conditioned to the specified or agreed temperature, and it shall be ensured that the temperature variation does not exceed $0,5 ^\circ\text{C}$ during testing.

6 Apparatus

Ordinary laboratory apparatus and glassware, together with the following.

6.1 Plummet, of non-corrodible metal, e.g. copper-zinc alloy (brass), stainless steel or aluminium, as illustrated in Figure 1. The type illustrated is available with a volume of 10 cm^3 or 100 cm^3 .

Dimensions in millimetres

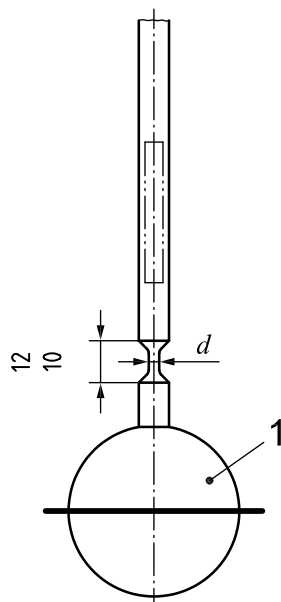

Key

- 1 volume 100 cm^3 or 10 cm^3 to the centre of the constriction in the stem
- d 3 mm for the 100 cm^3 plummet or 1 mm for the 10 cm^3 plummet

Figure 1 — Plummet

Each plummet shall be marked with its volume, the reference temperature and the surface tension and density of the reference liquid in the following form:

100 cm^3 $23 ^\circ\text{C}$ 25 mN/m $1,2 \text{ g/cm}^3$

6.2 Analytical balance, accurate to 10 mg.

6.3 Thermometer, accurate to $0,2 ^\circ\text{C}$ and graduated at intervals of $0,2 ^\circ\text{C}$ or finer.

6.4 Temperature-controlled chamber, capable of accommodating the balance, plummet and sample and maintaining them at the specified or agreed temperature (see Clause 5).

6.5 Tripod or other suitable device, for suspending the plummet and accurately adjusting its depth of immersion.

7 Sampling

Take a representative sample of the product under test, as described in ISO 15528. Examine and prepare the sample, as described in ISO 1513.

8 Procedure

8.1 General

Carry out a single determination on a fresh test sample.

The volume of the plummet shall be calibrated.

8.2 Determination

8.2.1 Selection of procedure

There are two procedures, one for all paints in general and one for those products containing fast-evaporating solvents.

8.2.2 Procedure A — For all paints in general

Ensure the plummet (6.1) is thoroughly clean before use. Place the plummet and the test sample next to the balance (6.2) in the temperature-controlled chamber (6.4) for approximately 30 min.

Place a sufficient volume of the test sample in a vessel of suitable size and capacity, e.g. 400 cm³ for a 100 cm³ plummet and 100 cm³ for a 10 cm³ plummet.

Using the thermometer (6.3), measure the temperature of the test sample. Check throughout the determination that the temperature of the chamber remains within the specified limits.

Place the vessel plus test sample on the balance and record the mass, m_1 (uncorrected for buoyancy), to the nearest 10 mg. Clamp the plummet onto the tripod (6.5) in such a way that it can be immersed in the sample without touching the sides of the vessel (see Figure 2).

Immerse the plummet in the sample until the surface of the liquid reaches the middle of the constriction in the plummet stem and record the mass, m_2 , to the nearest 10 mg.

NOTE If the balance is tared between weighings, mass $m_1 = 0$.

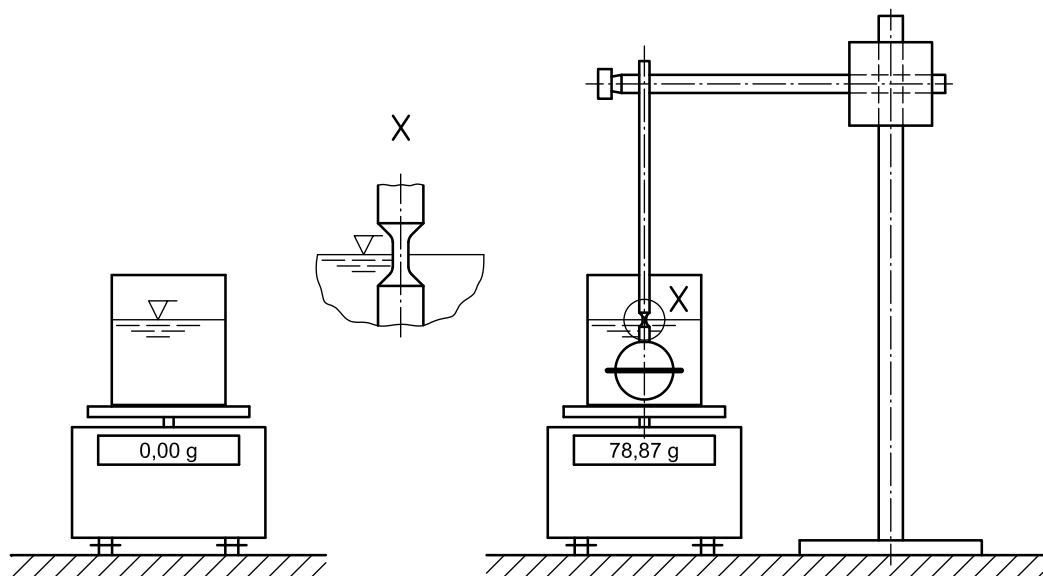

Figure 2 — Determination of density by the plummet method

8.2.3 Procedure B — For paints containing fast-evaporating solvents

Ensure that the plummet (6.1) is thoroughly clean before use. Place the plummet and the test sample next to the balance (6.2) in the temperature-controlled chamber (6.4) for approximately 30 min.

Using the thermometer (6.3), measure the temperature, t_T , of the test sample. Check throughout the determination that the temperature of the chamber remains within the specified limits.

Place a vessel of suitable size, containing a sufficient volume of test sample, on a laboratory jack.

Clamp the plummet onto a retort stand and place the stand on the balance in such a way that the plummet can be immersed in the sample by raising the laboratory jack without the plummet touching the sides of the vessel. Record the mass, m_2 , of the stand plus plummet.

Raise the laboratory jack until the surface of the liquid reaches the middle of the constriction in the plummet stem and record the mass, m_1 .

Equation (1) can be used to calculate the density, except that m_1 and m_2 are as follows:

m_1 is the mass of the retort stand and plummet after immersion of the plummet in the sample;

m_2 is the mass of the retort stand and plummet before immersion of the plummet.

9 Calculation

Calculate the density, ρ , of the product, in grams per cubic centimetre, at the test temperature, t_T , using Equation (1):

$$\rho = \frac{m_2 - m_1}{V_t} \quad (1)$$

where

m_1 is the mass, in grams, of the vessel containing the sample before immersion of the plummet;

m_2 is the mass, in grams, of the vessel after immersion of the plummet;

V_t is the volume, in cubic centimetres, of the plummet up to the middle of the constriction in the stem at the test temperature, t_T , determined in accordance with Annex B.

NOTE The result is not corrected for air buoyancy because the uncorrected value is required by most filling-machine control procedures and the correction (0,001 2 g/cm³) is negligible in relation to the precision of the method.

If the test temperature used is not the reference temperature, the density may be calculated using Equation (B.2).

10 Precision

10.1 General

The precision of the method depends on the characteristics of the product to be tested. For materials which contain no entrapped air, the values in 10.2 and 10.3 are valid.

10.2 Repeatability limit, r

The value below which the absolute difference between two single test results, obtained on identical material by one operator in one laboratory, within a short interval of time using the standardized test method, may be expected to lie, with a 95 % probability using the same equipment is

- 0,002 g/cm³ for solvents,
- 0,011 g/cm³ for coating materials using the 10 cm³ plummet, and
- 0,003 g/cm³ for coating materials using the 100 cm³ plummet.

10.3 Reproducibility limit, R

The value below which the absolute difference between two test results, obtained on identical material by operators in different laboratories using the standardized test method, may be expected to lie, with a 95 % probability, is

- 0,004 g/cm³ for solvents,
- 0,030 g/cm³ for coating materials using the 10 cm³ plummet, and
- 0,004 g/cm³ for coating materials using the 100 cm³ plummet.

11 Test report

The test report shall include at least the following information:

- a) all details necessary to identify the product tested;
- b) a reference to this part of ISO 2811, i.e. ISO 2811-2:2011;
- c) the type of plummet used and its volume (e.g. 100 cm³ ball);

- d) the test temperature;
- e) the result of the density measurement, in grams per cubic centimetre, rounded to the nearest 0,001 g/cm³;
- f) any deviation from the test method specified;
- g) any unusual features (anomalies) observed during the test;
- h) the date of the test.

Annex A (informative)

Example of a calibration method

A.1 Procedure

Clean the plummet thoroughly with a suitable solvent which does not leave a residue on evaporation.

Place the plummet and the liquid to be used for the determination of its volume next to the balance in the temperature-controlled chamber for approximately 30 min. Use a liquid of density similar to that of the paint products to be examined using the plummet. Pour a sufficient amount of the liquid into a suitable vessel, e.g. a 400 cm³ beaker for 100 cm³ plummets or a 100 cm³ beaker for 10 cm³ plummets.

Using the thermometer, measure the temperature of the liquid. Check throughout the determination that the temperature of the chamber remains within the specified limits.

Place the vessel plus liquid on the balance and record the mass, m_1 , to the nearest 10 mg. Clamp the plummet onto the tripod in such a way that it can be immersed in the liquid without touching the sides of the vessel (see Figure 2).

Immerse the plummet in the liquid until the surface of the liquid reaches the middle of the constriction in the plummet stem and record the mass, m_2 .

Immediately after the second weighing measure the temperature of the liquid. It is this temperature which is taken as the calibration temperature.

NOTE Distilled water can be used as the calibration liquid, but it has the disadvantage that its surface tension (72 mN/m) is higher than that of paints, varnishes and similar coating materials and their diluents. If water is used, a few drops of wetting agent are usually added to reduce the surface tension to about 30 mN/m to 40 mN/m. Alternatively, an organic solvent with a surface tension in the above range and whose density has been determined precisely using a glass pycnometer can be used.

A.2 Determination of volume of plummet

Calculate the volume, V_t , in cubic centimetres, of the plummet using Equation (A.1):

$$V_t = \frac{m_2 - m_1}{\rho_C} \quad (\text{A.1})$$

where

m_1 is the mass, in grams, of the vessel containing the liquid before immersion of the plummet;

m_2 is the mass, in grams, of the vessel after immersion of the plummet;

ρ_C is the density, in grams per cubic centimetre, of the calibration liquid.

Annex B (informative)

Temperature variation

B.1 Correction for thermal expansion of the plummet

If the test temperature, t_T , differs by more than 5 °C from the temperature at which the volume of the plummet is known, the density should preferably be corrected for the change in volume of the plummet.

Calculate, to five significant figures, the volume, V_t , in cubic centimetres, of the plummet at the test temperature using Equation (B.1):

$$V_t = V_C [1 + \gamma_P (t_T - t_C)] \quad (\text{B.1})$$

where

V_C is the volume, in cubic centimetres, of the plummet at the calibration temperature, t_C ;

γ_P is the volume coefficient of thermal expansion, in reciprocal degrees Celsius (°C⁻¹), of the material from which the plummet is made (see Table B.1);

t_T is the test temperature, in degrees Celsius;

t_C is the calibration temperature, in degrees Celsius.

Table B.1 — Coefficient of thermal expansion, γ_P , of materials used for plummets

Material	γ_P °C ⁻¹
Copper-zinc alloy (brass)	54×10^{-6} [value for CuZn37 (Ms63)]
Austenitic stainless steel	48×10^{-6}
Aluminium	69×10^{-6}

B.2 Calculation of density at the reference temperature from measurements at other temperatures

If the density of the product under test is determined at a temperature different from the reference temperature, the density, ρ_C , in grams per cubic centimetre, at the reference temperature can be calculated as given by Equation (B.2):

$$\rho_C = \frac{\rho_t}{[1 + \gamma_m(t_C - t_T)]} = \rho_t [1 - \gamma_m(t_C - t_T)] \quad (\text{B.2})$$

where

ρ_t is the density, in grams per cubic centimetre, of the product at the test temperature;

γ_m is the volume coefficient of thermal expansion of the product under test, the approximate value of γ_m being $2 \times 10^{-4} \text{ }^\circ\text{C}^{-1}$ for waterborne paints and $7 \times 10^{-4} \text{ }^\circ\text{C}^{-1}$ for other paints;

t_C is the reference temperature, in degrees Celsius;

t_T is the test temperature, in degrees Celsius.

British Standards Institution (BSI)

BSI is the national body responsible for preparing British Standards and other standards-related publications, information and services.

BSI is incorporated by Royal Charter. British Standards and other standardization products are published by BSI Standards Limited.

About us

We bring together business, industry, government, consumers, innovators and others to shape their combined experience and expertise into standards-based solutions.

The knowledge embodied in our standards has been carefully assembled in a dependable format and refined through our open consultation process. Organizations of all sizes and across all sectors choose standards to help them achieve their goals.

Information on standards

We can provide you with the knowledge that your organization needs to succeed. Find out more about British Standards by visiting our website at bsigroup.com/standards or contacting our Customer Services team or Knowledge Centre.

Buying standards

You can buy and download PDF versions of BSI publications, including British and adopted European and international standards, through our website at bsigroup.com/shop, where hard copies can also be purchased.

If you need international and foreign standards from other Standards Development Organizations, hard copies can be ordered from our Customer Services team.

Subscriptions

Our range of subscription services are designed to make using standards easier for you. For further information on our subscription products go to bsigroup.com/subscriptions.

With **British Standards Online (BSOL)** you'll have instant access to over 55,000 British and adopted European and international standards from your desktop. It's available 24/7 and is refreshed daily so you'll always be up to date.

You can keep in touch with standards developments and receive substantial discounts on the purchase price of standards, both in single copy and subscription format, by becoming a **BSI Subscribing Member**.

PLUS is an updating service exclusive to BSI Subscribing Members. You will automatically receive the latest hard copy of your standards when they're revised or replaced.

To find out more about becoming a BSI Subscribing Member and the benefits of membership, please visit bsigroup.com/shop.

With a **Multi-User Network Licence (MUNL)** you are able to host standards publications on your intranet. Licences can cover as few or as many users as you wish. With updates supplied as soon as they're available, you can be sure your documentation is current. For further information, email bsmusales@bsigroup.com.

BSI Group Headquarters

389 Chiswick High Road London W4 4AL UK

Revisions

Our British Standards and other publications are updated by amendment or revision.

We continually improve the quality of our products and services to benefit your business. If you find an inaccuracy or ambiguity within a British Standard or other BSI publication please inform the Knowledge Centre.

Copyright

All the data, software and documentation set out in all British Standards and other BSI publications are the property of and copyrighted by BSI, or some person or entity that owns copyright in the information used (such as the international standardization bodies) and has formally licensed such information to BSI for commercial publication and use. Except as permitted under the Copyright, Designs and Patents Act 1988 no extract may be reproduced, stored in a retrieval system or transmitted in any form or by any means – electronic, photocopying, recording or otherwise – without prior written permission from BSI. Details and advice can be obtained from the Copyright & Licensing Department.

Useful Contacts:

Customer Services

Tel: +44 845 086 9001

Email (orders): orders@bsigroup.com

Email (enquiries): cservices@bsigroup.com

Subscriptions

Tel: +44 845 086 9001

Email: subscriptions@bsigroup.com

Knowledge Centre

Tel: +44 20 8996 7004

Email: knowledgecentre@bsigroup.com

Copyright & Licensing

Tel: +44 20 8996 7070

Email: copyright@bsigroup.com



...making excellence a habit.™