

Paints and varnishes — Determination of film thickness

The European Standard EN ISO 2808:2007 has the status of a
British Standard

ICS 87.040

National foreword

This British Standard was published by BSI. It is the UK implementation of EN ISO 2808:2007. It supersedes BS EN ISO 2808:2001 which is withdrawn.

The UK participation in its preparation was entrusted to Technical Committee STI/10, Test methods for paints.

A list of organizations represented on STI/10 can be obtained on request to its secretary.

This publication does not purport to include all the necessary provisions of a contract. Users are responsible for its correct application.

Compliance with a British Standard cannot confer immunity from legal obligations.

This British Standard was published under the authority of the Standards Policy and Strategy Committee on 30 March 2007

© BSI 2007

ISBN 978 0 580 50319 1

Amendments issued since publication

Amd. No.	Date	Comments

EUROPEAN STANDARD

EN ISO 2808

NORME EUROPÉENNE

EUROPÄISCHE NORM

February 2007

ICS 87.040

Supersedes EN ISO 2808:1999

English Version

Paints and varnishes - Determination of film thickness (ISO 2808:2007)

Peintures et vernis - Détermination de l'épaisseur du feuillet
(ISO 2808:2007)

Beschichtungsstoffe - Bestimmung der Schichtdicke (ISO 2808:2007)

This European Standard was approved by CEN on 16 December 2006.

CEN members are bound to comply with the CEN/CENELEC Internal Regulations which stipulate the conditions for giving this European Standard the status of a national standard without any alteration. Up-to-date lists and bibliographical references concerning such national standards may be obtained on application to the CEN Management Centre or to any CEN member.

This European Standard exists in three official versions (English, French, German). A version in any other language made by translation under the responsibility of a CEN member into its own language and notified to the CEN Management Centre has the same status as the official versions.

CEN members are the national standards bodies of Austria, Belgium, Bulgaria, Cyprus, Czech Republic, Denmark, Estonia, Finland, France, Germany, Greece, Hungary, Iceland, Ireland, Italy, Latvia, Lithuania, Luxembourg, Malta, Netherlands, Norway, Poland, Portugal, Romania, Slovakia, Slovenia, Spain, Sweden, Switzerland and United Kingdom.



EUROPEAN COMMITTEE FOR STANDARDIZATION
COMITÉ EUROPÉEN DE NORMALISATION
EUROPÄISCHES KOMITEE FÜR NORMUNG

Management Centre: rue de Stassart, 36 B-1050 Brussels

Foreword

This document (EN ISO 2808:2007) has been prepared by Technical Committee ISO/TC 35 "Paints and varnishes" in collaboration with Technical Committee CEN/TC 139 "Paints and varnishes", the secretariat of which is held by DIN.

This European Standard shall be given the status of a national standard, either by publication of an identical text or by endorsement, at the latest by August 2007, and conflicting national standards shall be withdrawn at the latest by August 2007.

This document supersedes EN ISO 2808:1999.

According to the CEN/CENELEC Internal Regulations, the national standards organizations of the following countries are bound to implement this European Standard: Austria, Belgium, Bulgaria, Cyprus, Czech Republic, Denmark, Estonia, Finland, France, Germany, Greece, Hungary, Iceland, Ireland, Italy, Latvia, Lithuania, Luxembourg, Malta, Netherlands, Norway, Poland, Portugal, Romania, Slovakia, Slovenia, Spain, Sweden, Switzerland and United Kingdom.

Endorsement notice

The text of ISO 2808:2007 has been approved by CEN as EN ISO 2808:2007 without any modifications.

INTERNATIONAL
STANDARD

ISO
2808

Fourth edition
2007-02-01

**Paints and varnishes — Determination of
film thickness**

Peintures et vernis — Détermination de l'épaisseur du feuil



Reference number
ISO 2808:2007(E)

Contents

Page

Foreword.....	v
Introduction	vi
1 Scope	1
2 Normative references	1
3 Terms and definitions	1
4 Determination of wet-film thickness	3
4.1 General	3
4.2 Mechanical methods	3
4.2.1 Principle	3
4.2.2 Field of application	3
4.2.3 General	3
4.2.4 Method 1A — Comb gauge	4
4.2.5 Method 1B — Wheel gauge	5
4.2.6 Method 1C — Dial gauge	6
4.3 Gravimetric method	7
4.3.1 Principle	7
4.3.2 Field of application	7
4.3.3 General	7
4.3.4 Method 2 — By difference in mass	7
4.4 Photothermal method	8
4.4.1 Principle	8
4.4.2 Field of application	8
4.4.3 General	9
4.4.4 Method 3 — Determination using thermal properties	9
5 Determination of dry-film thickness	9
5.1 General	9
5.2 Mechanical methods	9
5.2.1 Principle	9
5.2.2 Field of application	10
5.2.3 General	10
5.2.4 Method 4A — By difference in thickness	11
5.2.5 Method 4B — Depth gauging	13
5.2.6 Method 4C — Surface profile scanning	15
5.3 Gravimetric method	16
5.3.1 Principle	16
5.3.2 Field of application	16
5.3.3 General	16
5.3.4 Method 5 — By difference in mass	16
5.4 Optical methods	17
5.4.1 Principle	17
5.4.2 Field of application	18
5.4.3 General	18
5.4.4 Method 6A — Cross-sectioning	19
5.4.5 Method 6B — Wedge cut	20
5.5 Magnetic methods	20
5.5.1 General	20
5.5.2 Principle	20
5.5.3 Field of application	20
5.5.4 General	21

5.5.5	Method 7A — Magnetic pull-off gauge.....	21
5.5.6	Method 7B — Magnetic-flux gauge	22
5.5.7	Method 7C — Magnetic-induction gauge	22
5.5.8	Method 7D — Eddy-current gauge	23
5.6	Radiological method	24
5.6.1	Principle	24
5.6.2	Field of application	24
5.6.3	General	24
5.6.4	Method 8 — Beta backscatter method	25
5.7	Photothermal method	25
5.7.1	Principle	25
5.7.2	Field of application	26
5.7.3	General	26
5.7.4	Method 9 — Determination using thermal properties	27
5.8	Acoustic method	27
5.8.1	Principle	27
5.8.2	Field of application	27
5.8.3	General	27
5.8.4	Method 10 — Ultrasonic thickness gauge	28
6	Determination of thickness of uncured powder layers	28
6.1	General	28
6.2	Gravimetric method	29
6.2.1	Principle	29
6.2.2	Field of application	29
6.2.3	General	29
6.2.4	Method 11 — By difference in mass	29
6.3	Magnetic methods.....	29
6.3.1	Principle	29
6.3.2	Field of application	29
6.3.3	General	30
6.3.4	Method 12A — Magnetic-induction gauge	30
6.3.5	Method 12B — Eddy-current gauge	31
6.4	Photothermal method	31
6.4.1	Principle	31
6.4.2	Field of application	31
6.4.3	General	31
6.4.4	Method 13 — Determination using thermal properties	31
7	Measurement of film thickness on rough surfaces	32
7.1	General	32
7.2	Apparatus and materials	33
7.3	Procedure.....	33
7.3.1	Verification	33
7.3.2	Measurement	33
7.3.3	Number of readings	33
8	Test report.....	33
	Annex A (informative) Overview of methods	35
	Bibliography	38

Foreword

ISO (the International Organization for Standardization) is a worldwide federation of national standards bodies (ISO member bodies). The work of preparing International Standards is normally carried out through ISO technical committees. Each member body interested in a subject for which a technical committee has been established has the right to be represented on that committee. International organizations, governmental and non-governmental, in liaison with ISO, also take part in the work. ISO collaborates closely with the International Electrotechnical Commission (IEC) on all matters of electrotechnical standardization.

International Standards are drafted in accordance with the rules given in the ISO/IEC Directives, Part 2.

The main task of technical committees is to prepare International Standards. Draft International Standards adopted by the technical committees are circulated to the member bodies for voting. Publication as an International Standard requires approval by at least 75 % of the member bodies casting a vote.

Attention is drawn to the possibility that some of the elements of this document may be the subject of patent rights. ISO shall not be held responsible for identifying any or all such patent rights.

ISO 2808 was prepared by Technical Committee ISO/TC 35, *Paints and varnishes*, Subcommittee SC 9, *General test methods for paints and varnishes*.

This fourth edition cancels and replaces the third edition (ISO 2808:1997), which has been technically revised. The main changes are as follows:

- a) The structure of the standard has been changed into four main clauses:
 - 1) determination of wet-film thickness;
 - 2) determination of dry-film thickness;
 - 3) determination of the thickness of uncured powder layers; and
 - 4) measurement of film thickness on rough surfaces.
- b) Methods using photothermal, radiological and acoustic techniques have been added.
- c) The split-beam method has been deleted as such instruments are no longer manufactured.

Introduction

Measurement of film thickness depends on the following steps:

- a) calibration of the measurement instrument, typically performed by the manufacturer or by any qualified laboratory;
- b) verification of the instrument (an accuracy check performed by the user at regular intervals, typically before each series of measurements);
- c) subsequent adjustment, if necessary, of the instrument so that the thickness readings it gives match those of a specimen of known thickness. For a dry-film thickness gauge this would mean zeroing it on the uncoated surface, using devices of known thickness such as shims, or using a coated specimen of known film thickness;
- d) measurement.

Paints and varnishes — Determination of film thickness

1 Scope

This International Standard describes a number of methods that are applicable to the measurement of the thickness of coatings applied to a substrate. Methods for determining wet-film thickness, dry-film thickness and the film thickness of uncured powder layers are described. Reference is made to individual standards where these exist. Otherwise the method is described in detail.

An overview on the methods is given in Annex A, in which the field of application, existing standards and the precision are specified for the individual methods.

This International Standard also defines terms concerning the determination of film thickness.

2 Normative references

The following referenced documents are indispensable for the application of this document. For dated references, only the edition cited applies. For undated references, the latest edition of the referenced document (including any amendments) applies.

ISO 463, *Geometrical Product Specifications (GPS) — Dimensional measuring equipment — Design and metrological characteristics of mechanical dial gauges*

ISO 3611, *Micrometer callipers for external measurement*

ISO 4618:2006, *Paints and varnishes — Terms and definitions*

ISO 8503-1, *Preparation of steel substrates before application of paints and related products — Surface roughness characteristics of blast-cleaned steel substrates — Part 1: Specifications and definitions for ISO surface profile comparators for the assessment of abrasive blast-cleaned surfaces*

3 Terms and definitions

For the purposes of this document, the terms and definitions given in ISO 4618 and the following apply.

3.1

substrate

surface to which a coating material is applied or is to be applied

[ISO 4618:2006]

3.2

coating

continuous layer formed from a single or multiple application of a coating material to a substrate

[ISO 4618:2006]

- 3.3**
film thickness
distance between the surface of the film and the surface of the substrate
- 3.4**
wet-film thickness
thickness of a freshly applied wet coating material, measured immediately after application
- 3.5**
dry-film thickness
thickness of a coating remaining on the surface when the coating has hardened
- 3.6**
thickness of uncured powder layer
thickness of a freshly applied coating material in powder form, measured immediately after application and before stoving
- 3.7**
relevant surface area¹⁾
part of an article covered or to be covered by the coating and for which the coating is essential for serviceability and/or appearance
- 3.8**
test area¹⁾
representative part of the relevant surface area within which an agreed number of single measurements is made as a spot-check
- 3.9**
measurement area¹⁾
area over which a single measurement is made
- 3.10**
minimum local film thickness¹⁾
lowest value of the local film thickness found on the relevant surface area of a particular test specimen
- 3.11**
maximum local film thickness¹⁾
highest value of the local film thickness found on the relevant surface area of a particular test specimen
- 3.12**
mean film thickness¹⁾
arithmetic mean of all the individual dry-film thicknesses in the test area or the result of a gravimetric determination of the thickness
- 3.13**
calibration
controlled and documented process of measuring traceable calibration standards and verifying that the results are within the stated accuracy of the measurement instrument

NOTE Initial calibration is typically performed by the instrument manufacturer or by a qualified laboratory in a controlled environment using a documented process. This initial calibration will normally be verified by the user at regular intervals. The standards used in the calibration are such that the combined uncertainties of the resultant measurement are less than the stated accuracy of the instrument.

¹⁾ Measurement of this property is only required for the extended evaluation of film thickness measurements; see Clause 8 (test report), items k) and l).

3.14**verification**

accuracy check performed by the user using reference standards

3.15**reference standard**

specimen of known thickness against which a user can verify the accuracy of the measurement instrument

NOTE Reference standards may be coated thickness standards, or shims. If agreed to by the contracting parties, a part of the test specimen may be used as a thickness standard for a particular job.

3.16**adjustment**

act of aligning the measurement instrument's thickness readings to match those of a reference standard

NOTE Most electronic measurement instruments can be adjusted on a thickness standard or on a shim, where the thickness of the coating or of the shim is known.

3.17**accuracy**

consistency between a measured value and the true value of the thickness standard

4 Determination of wet-film thickness**4.1 General**

Annex A gives an overview of the methods used for the determination of wet-film thickness.

4.2 Mechanical methods**4.2.1 Principle**

In all mechanical methods the substrate surface is contacted by part of the measurement instrument through the coating, and the surface of the coating is contacted simultaneously (see Figure 1) or subsequently (see Figures 2 and 3) by another part of the instrument. The wet-film thickness is the height difference between these two points of contact, which can be read directly.

4.2.2 Field of application

The mechanical principle is suitable for all film-substrate combinations. The substrate has to be flat in at least one direction in the area where the measurement is conducted. Curvature of the surface in a single plane is permissible (e.g. internal or external surface of pipes).

4.2.3 General

Classification as a destructive or non-destructive method depends on:

- a) the rheological properties of the coating material;
- b) the nature of the wetting contact between the contact surfaces of the measurement instrument and the coating material;
- c) whether the thickness measurements will make the coating unsuitable for the purpose for which it is intended.

Since the possibility of pigment particles remaining between the gauge and the substrate cannot be excluded, all mechanical methods contain a systematic error: the film thickness displayed is smaller than the actual wet-film thickness by at least the mean diameter of the pigment particles.

In the case of a wheel gauge (method 1B, see 4.2.5), the wheel has to be wetted by the coating material. If not, this represents a further source of systematic error which can result in exaggerated readings and is a function of:

- the surface tension and the rheological properties of the coating material;
- the material of the wheel gauge;
- the speed at which the wheel is turned.

4.2.4 Method 1A — Comb gauge

4.2.4.1 Description of instrument

A comb gauge is a flat plate made of a corrosion-resistant material with teeth along its edges (see Figure 1). The reference teeth at the corners of the plate define a baseline along which the inner teeth are arranged to give a graduated series of gaps. Each tooth is labelled with the assigned gap value.

With commercially available comb gauges the maximum thickness which can be measured is typically 2 000 µm and the smallest increment is typically 5 µm.

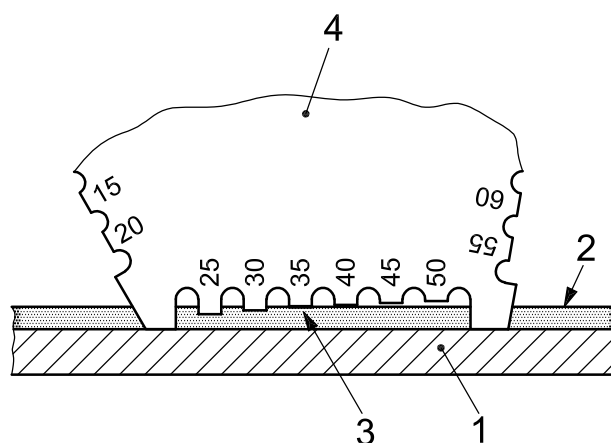

Key

- 1 substrate
- 2 coating
- 3 point of wetting contact
- 4 comb gauge

Figure 1 — Example of a comb gauge

4.2.4.2 Procedure

Ensure that the teeth are clean and not worn or damaged. Place the comb gauge onto the flat specimen surface such that the teeth are normal to the plane of the surface. Allow sufficient time for the coating to wet the teeth prior to removing the gauge.

In the case of specimens curved in a single plane, the comb gauge shall be placed in position parallel to the axis of curvature.

The result of the thickness measurement depends on the time of measurement. The thickness should therefore be measured as soon as possible after application.

Note the greatest gap reading of the tooth wetted by the coating material as the wet-film thickness.

4.2.5 Method 1B — Wheel gauge

4.2.5.1 Description of instrument

A wheel gauge consists of a wheel, made of hardened and corrosion-resistant steel, with three projecting rims (see Figure 2).

Two rims are ground to the same diameter and are configured concentrically to the wheel axle. The third rim has a smaller diameter and is eccentrically ground. One of the outer rims has a scale from which the respective projection of the concentric rims relative to the eccentric rim can be read.

Two versions are available:

- version 1 has the eccentric rim located between the concentric rims;
- version 2 has the eccentric rim located outside the concentric rims and closely adjacent to one of them.

NOTE Unlike version 1, the design of version 2 allows parallax-free reading of the wet-film thickness.

With commercially available wheel gauges, the maximum thickness which can be measured is typically 1 500 μm and the smallest increment is typically 2 μm .

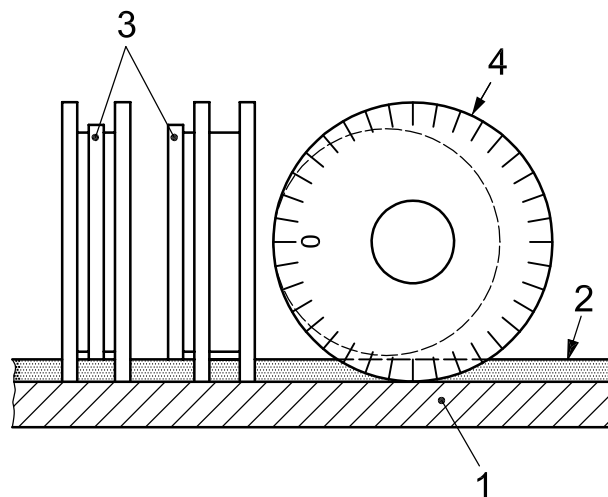

Key

- 1 substrate
- 2 coating
- 3 eccentric rim
- 4 wheel gauge

Figure 2 — Example of a wheel gauge

4.2.5.2 Procedure

Grip the wheel gauge with the thumb and index finger by the wheel axle and press the concentric rims onto the surface at the point of the largest reading on the scale.

In the case of specimens curved in a single plane, the axis of curvature and the wheel gauge axle shall be parallel.

Roll the wheel gauge in one direction, lift it from the surface and read off the highest scale reading at which the eccentric rim is still wetted by the coating material. Clean the gauge and repeat in the other direction.

Calculate the wet-film thickness as the arithmetic mean of these readings.

The result of the thickness measurement depends on the time of measurement. The thickness should therefore be measured as soon as possible after application.

To minimize the effect of surface tension on the result, observe how the paint wets the eccentric rim and record the scale reading at the first point of contact. This is only possible with version 2 of the wheel gauge.

4.2.6 Method 1C — Dial gauge

4.2.6.1 Instrument and reference standards

4.2.6.1.1 Dial gauge (see Figure 3)

Mechanical dial gauges conforming to the requirements of ISO 463 and electronic dial gauges are typically capable of measuring to an accuracy of 5 μm (mechanical dial gauge) or 1 μm (electronic dial gauge), or better. The gauge can have an analogue or digital display.

The underside of the dial gauge has two contact pins of equal length located equidistant from the movable plunger and in a straight line with it. An adjusting screw is used to make fine adjustments to the position of the plunger in its guideway.

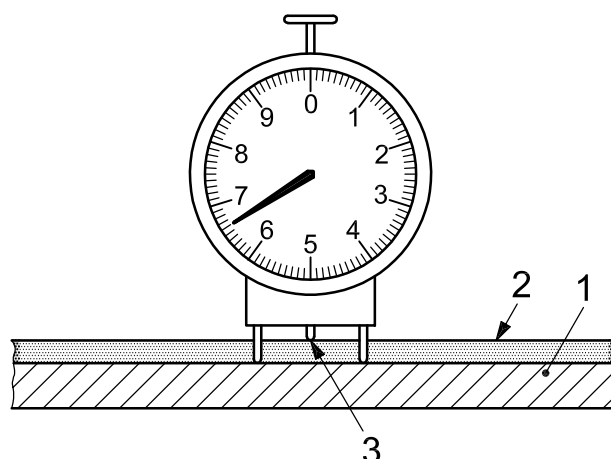

Key

- 1 substrate
- 2 coating
- 3 plunger

Figure 3 — Example of a dial gauge

4.2.6.1.2 Reference standard for zeroing the gauge

A flat reference plate is required for zeroing the gauge. The reference plate shall consist of a flat glass plate whose flatness tolerance does not exceed 1 μm (see also ISO 1101 ^[1]).

4.2.6.2 Procedure

Zero the dial gauge on the reference plate with the measuring tip adjusted so that it is just touching the plate.

Screw the plunger back from the zeroing position. Place the contact pins of the dial gauge on the specimen so that they are normal to the surface of the substrate and carefully screw the plunger down until the measuring tip is just touching the coating material.

The result of the thickness measurement depends on the time of measurement. The thickness should therefore be measured as soon as possible after application.

Read the wet-film thickness directly from the gauge.

4.3 Gravimetric method

4.3.1 Principle

A coating is applied and the thickness is determined by dividing the mass of the coating by its density and by the coated surface area.

The wet-film thickness, t_w , in micrometres, is calculated from the equation

$$t_w = \frac{m - m_0}{A \cdot \rho} \quad (1)$$

where

m_0 is the mass of the uncoated specimen, in grams;

m is the mass of the coated specimen, in grams;

A is the coated surface area, in square metres;

ρ is the density of the liquid coating material applied, in grams per millilitre.

NOTE The density of the liquid coating material applied can be determined in accordance with ISO 2811-1, ISO 2811-2, ISO 2811-3 or ISO 2811-4.

4.3.2 Field of application

The gravimetric principle is generally applicable, provided that the amount of highly volatile substances in the liquid coating material is low.

4.3.3 General

Determination using the gravimetric principle yields the mean value of the wet-film thickness over the entire coated surface area. With spray application in particular, the reverse side of the specimen shall be masked to prevent measurement errors resulting from partial coating of the reverse (overspray). Any masking of the reverse side shall be removed before weighing the coated specimen.

4.3.4 Method 2 — By difference in mass

4.3.4.1 Apparatus

Required are scales capable of weighing up to 500 g to the nearest 1 mg.

4.3.4.2 Procedure

Weigh the specimen first uncoated and then coated and calculate the wet-film thickness using Equation (1).

4.4 Photothermal method

4.4.1 Principle

The film thickness is determined from the difference between the time a thermal wave is radiated towards the coating and the time the re-emitted wave (either heat or ultrasonic) is detected (see Figure 4).

Irrespective of the type of excitation involved or the method of detection, all photothermal methods use the same principle: the periodic or pulsed introduction of energy in the form of heat into a specimen and the subsequent detection of the local temperature increase.

The time difference measured is compared against values obtained with the instrument for films of known thickness under fixed conditions (excitation energy, pulse length, excitation frequency, etc.) (see 4.4.4.2).

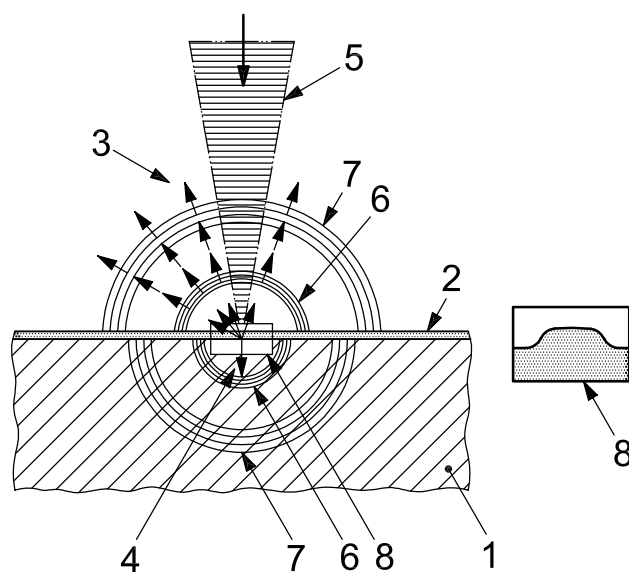

Key

- 1 substrate
- 2 coating
- 3 re-emitted thermal radiation
- 4 absorption of radiation by coating (depends on coating thickness and coating material)
- 5 thermal irradiation
- 6 thermal waves
- 7 ultrasonic waves
- 8 surface deformation

Figure 4 — Interaction of radiation with the specimen in photothermal thickness measurement, showing surface deformation

4.4.2 Field of application

The photothermal principle is basically suitable for all film-substrate combinations. It can also be used to determine the thicknesses of the individual layers in a multilayer coating, provided the layers are sufficiently distinct from each other with respect to their thermal conductivity and reflection properties.

The required minimum substrate thickness is a function of the measurement system used (see 4.4.4.1.1) and the film-substrate combination.

4.4.3 General

Classification of the method as destructive or non-destructive depends on the purpose of the coating. The thermal energy absorbed by the coating could have an impact on the coating owing to the local heating effect produced (see item 8 in Figure 4).

4.4.4 Method 3 — Determination using thermal properties

4.4.4.1 Instrument and reference standards

4.4.4.1.1 Measurement system

There are various methods for producing thermal waves in a coating material and for detecting the thermal effects induced at the heated location in the specimen (see EN 15042-2 ^[18]). Thermal radiation sources (e.g. laser sources, light-emitting diodes, incandescent light sources) are mainly used as the excitation system for paint coatings.

The following detection methods are used:

- detection of the re-emitted thermal radiation (photothermal radiometry);
- detection of the change in refractive index (in the heated air above the measurement area);
- pyroelectric detection (heat flow measurement).

4.4.4.1.2 Reference standards

Reference specimens with different absorption properties and a range of film thicknesses are required for calibration purposes (see EN 15042-2 ^[18]).

4.4.4.2 Calibration

Calibrate the measurement system with the reference specimens (see 4.4.4.1.2) for each film-substrate combination (in particular for each coating material).

4.4.4.3 Procedure

Operate the apparatus and measure the film thickness in accordance with the manufacturer's instructions.

5 Determination of dry-film thickness

5.1 General

Annex A gives an overview of the methods used for determination of dry-film thickness.

5.2 Mechanical methods

5.2.1 Principle

A micrometer or dial gauge (method 4A, see 5.2.4) is used to measure the film thickness as the difference between the total thickness (substrate + film) and the substrate thickness.

There are two ways of determining the film thickness:

- a) Measurements are made before and after coating removal (destructive)

The total thickness is first measured in a defined measurement area and then, after the coating has been removed in the measurement area, the substrate thickness is measured.

- b) Measurements are made before and after coating application (non-destructive)

The substrate thickness is first measured and then the total thickness is measured in the same measurement area after coating.

The film thickness is calculated from the difference between the two readings.

A depth gauge (method 4B, see 5.2.5) or a profilometer (method 4C, see 5.2.6) enable the film thickness to be determined directly as the difference in height between the surface of the film and the surface of the exposed substrate.

NOTE Only the "coating removal" variant is possible with a depth gauge or profilometer (methods 4B and 4C).

5.2.2 Field of application

The mechanical principle is basically suitable for all film-substrate combinations. Where mechanical gauging is used, the substrate and coating shall be hard enough to prevent the reading from being falsified as a result of the measuring tip creating an indentation.

The micrometer or dial gauge (method 4A) is also suitable for measuring the film thickness of cylindrical specimens of circular cross-section (e.g. wires, pipes).

The profilometer (method 4C) is recognized as the referee method in the event of disputes.

5.2.3 General

In the "coating application" variant, a template with labelled holes is used to ensure that the determination of the substrate thickness and total thickness is carried out at exactly the same points.

NOTE 1 The "coating application" variant is preferred in the case of plastic substrates since in most cases the substrate cannot be exposed without causing damage.

In the "coating removal" variant, the measurement areas shall be circled and labelled. The coating shall be carefully and completely removed in the measurement areas without damaging the substrate mechanically or chemically. The substrate may be partly masked using adhesive tape before coating in order to obtain well-defined steps from one layer to the next.

In the case of the depth gauge and profilometer (methods 4B and 4C), the coating which is not removed in the region of the measurement area shall remain undamaged.

In the case of the profilometer (method 4C), the shoulder between the substrate and the film surface shall be sufficiently well defined.

With hard substrates (e.g. glass) the coating can be removed mechanically, but with less hard substrates (e.g. steel) the coating shall be removed chemically using a solvent or paint remover.

NOTE 2 In the case of less hard substrate materials such as steel, the film can be cut through with a core drill of 10 mm diameter and the disc of coating thus formed removed with a solvent or paint remover.

All surfaces (coating, substrate, reverse side of specimen) which are contacted or gauged shall be clean and free from film residues.

5.2.4 Method 4A — By difference in thickness

5.2.4.1 Description of instrument

5.2.4.1.1 Micrometer

The micrometer shall be capable of measuring to the nearest 5 μm . It shall be fitted with a ratchet to limit the force exerted by the spindle on the test surface.

Version 1 — Fixed to a stand

A micrometer head with a plane measuring face is clamped to a rigid stand with a flat baseplate such that its height can be adjusted. The measuring face shall be aligned parallel to the top of the baseplate.

Version 2 — Hand-held (see Figure 5)

The usual term for this kind of instrument is an outside micrometer, although it is also known as micrometer callipers for external use (see ISO 3611). The micrometer shall conform to the requirements of ISO 3611. The measuring faces of the spindle and the anvil shall be plane and parallel to each other.

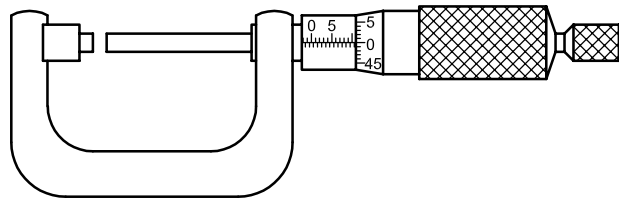

Figure 5 — Outside micrometer

5.2.4.1.2 Dial gauge

Mechanical dial gauges conforming to the requirements of ISO 463 and electronic dial gauges are typically capable of measuring to an accuracy of 5 μm (mechanical dial gauge) or 1 μm (electronic dial gauge), or better. The gauge shall be fitted with a device for lifting the measuring tip. The shape of the measuring tip shall be selected as a function of the hardness of the coating material whose thickness is to be measured (spherical for hard materials, plane for soft materials).

Version 1 — Fixed to a stand

The dial gauge is clamped to a stand as shown in Figure 6. If a plane stylus tip is used, the measurement surface shall be aligned parallel to the top of the baseplate.

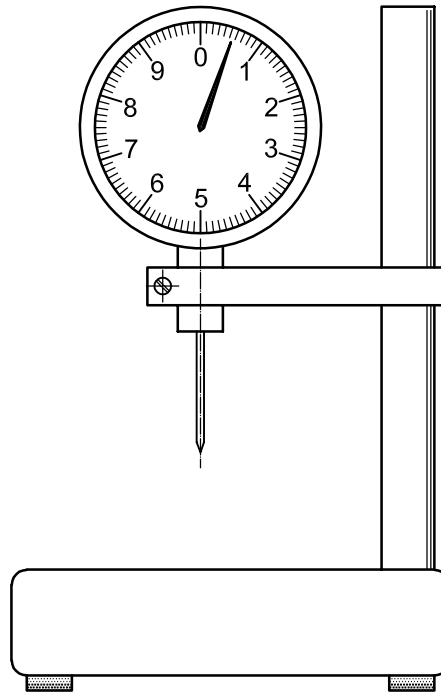
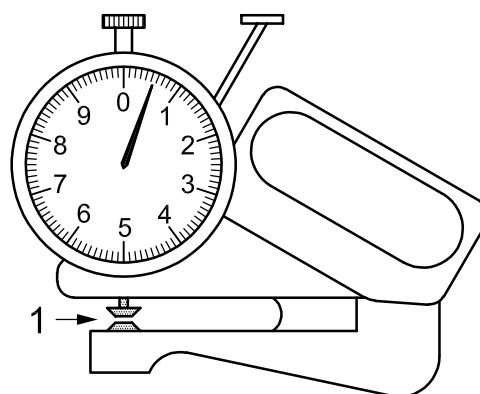

Figure 6 — Dial gauge fixed to a stand

Version 2 — Hand-held

This dial gauge is fitted with a hand grip. The device for lifting the plunger shall be configured such that the thickness gauge can be operated with one hand. The interchangeable tip of the anvil shall be located opposite the movable measuring tip. The shape of the measuring tip shall be selected as a function of the hardness of the material to be tested (spherical for hard materials, plane for soft materials).

If both the measuring tip and the anvil are of plane design (such as in the foil thickness gauge shown in Figure 7), the measurement surfaces shall be parallel to each other.



Key

- 1 gauge aperture

Figure 7 — Foil thickness gauge

5.2.4.2 Procedure

Prepare the specimen as specified in 5.2.3 for the “coating removal” and “coating application” variants (see 5.2.1).

Operate all instruments so that the coated side of the specimen or the side to be coated is facing the spindle (micrometer, see 5.2.4.1.1) or the contact element (dial gauge, see 5.2.4.1.2) in the “coating removal” and “coating application” variants, respectively.

When using an instrument clamped to a stand (5.2.4.1.1 and 5.2.4.1.2, version 1 in each case) place the specimen on the baseplate.

When using a hand-held type (5.2.4.1.1 and 5.2.4.1.2, version 2 in each case) hold the specimen against the fixed measuring tip.

NOTE The grip of the instruments specified in 5.2.4.1.1 and 5.2.4.1.2, version 2 in each case, can be clamped to a stand to make operation easier.

Repeat the procedure for the second measurement after removing the film (“coating removal”) or applying the film (“coating application”).

Carry out each measurement such that:

- when using a micrometer as described in 5.2.4.1.1, the spindle is moved against the surface to be tested until the ratchet is activated;
- when using a dial gauge as described in 5.2.4.1.2, the surface is carefully contacted by the tip of the spring-loaded contact element.

The film thickness is the difference between the reading obtained for the total thickness and that obtained for the substrate thickness.

5.2.5 Method 4B — Depth gauging

5.2.5.1 Instrument and reference standards

5.2.5.1.1 Version 1 — Micrometer depth gauge (see Figure 8)

Micrometers of this type are typically capable of measuring to the nearest 5 μm , or better. The micrometer shall be fitted with a ratchet to limit the force exerted by the contact element on the substrate. It has a flat base or foot which is placed on the coating surface and acts as a reference plane.

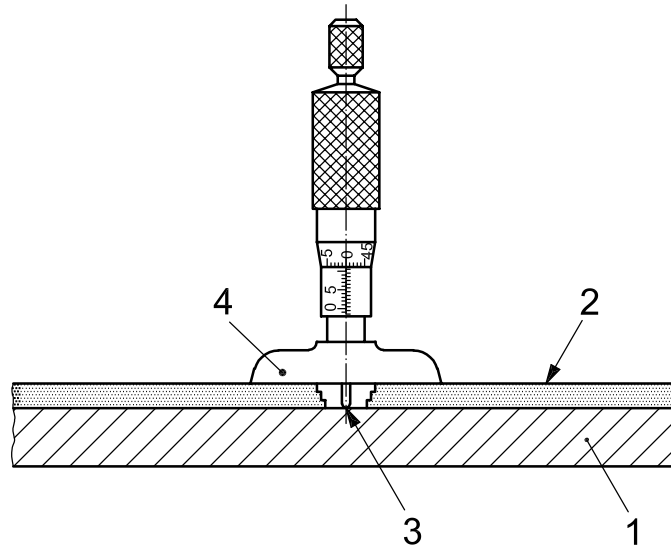

Key

- 1 substrate
- 2 coating
- 3 contact element
- 4 flat base or foot

Figure 8 — Micrometer depth gauge

5.2.5.1.2 Version 2 — Dial depth gauge (see Figure 9)

Mechanical dial gauges conforming to the requirements of ISO 463 and electronic dial gauges are typically capable of measuring to an accuracy of 5 µm (mechanical dial gauge) or 1 µm (electronic dial gauge), or better. The gauge can have a flat base or foot which is placed on the coating surface and acts as a reference plane.

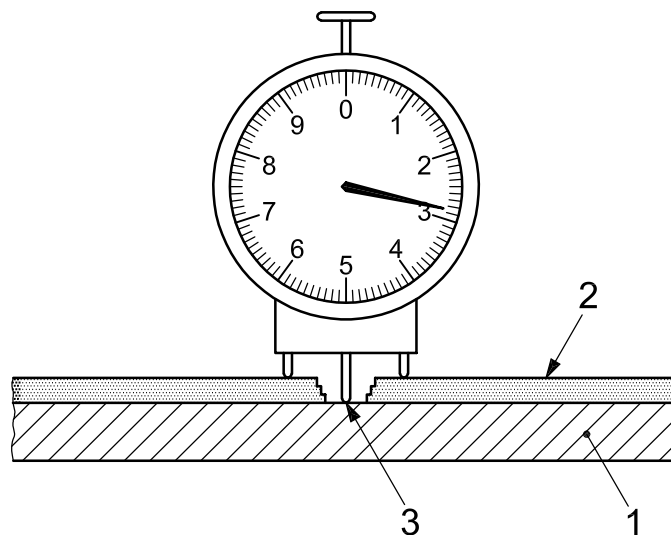

Key

- 1 substrate
- 2 coating
- 3 contact element

Figure 9 — Dial depth gauge

5.2.5.1.3 Reference standard for zeroing the gauge

A flat reference plate is required for zeroing the gauge. The reference plate shall consist of a flat glass plate whose flatness tolerance does not exceed 1 μm (see also ISO 1101 [1]).

5.2.5.2 Procedure

Remove the coating from the measurement area. Zero the instrument by checking the zero point with the reference plate (5.2.5.1.3) and then:

- when using a micrometer depth gauge, place the foot on the coating surface so that the spindle is above the exposed area and screw the spindle down until the tip touches the substrate and the ratchet is actuated;
- when using a dial depth gauge, place the contact element on the exposed substrate and the foot (or contact pins) on the coating (if the gauge is of the type with contact pins, care shall be taken to ensure that they are normal to the specimen surface).

The film thickness can be read off directly as a depth reading (correcting, as necessary, for any zero error).

5.2.6 Method 4C — Surface profile scanning

5.2.6.1 Description of instrument

This instrument comprises a traversing stylus connected to suitable amplifying and recording equipment. For the purposes of film-thickness measurements, the instrument is used to record the profile of a shoulder formed between the substrate and the coating by removal of part of the coating (see Figure 10). Roughness or profile gauges with a freely moving stylus in which the radius of the stylus tip is selected to match the roughness of the substrate and film surface are the most suitable.

NOTE Measurements can also be made optically or acoustically (i.e. without any contact with the specimen).

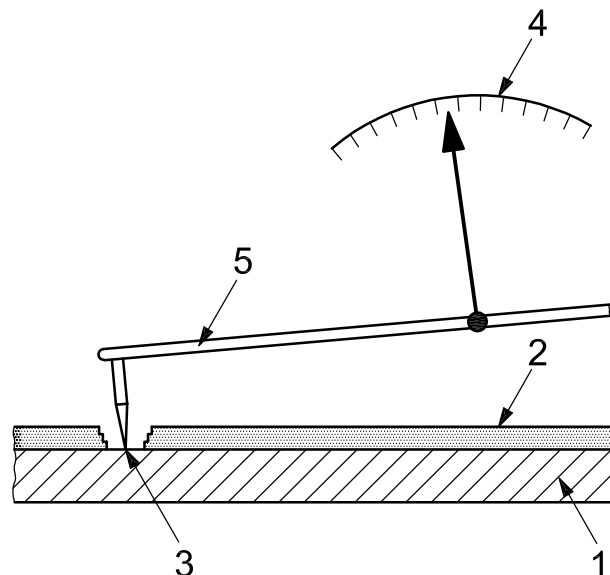

Key

- substrate
- coating
- stylus tip
- scale
- lever

Figure 10 — Surface profile scanner

5.2.6.2 Procedure

Prepare the specimen as specified in 5.2.3. Scan and record the surface profile in the measurement area using an appropriate monitor and plotter.

The following factors can adversely affect the readings:

- inadequately cleaned surfaces;
- vibrations in the gauging system;
- the use of an unsuitable stylus tip.

Draw reference lines through the mean height of the trace recorded for the film surface (upper line) and through the trace recorded for the substrate (lower line). Measure the film thickness as the distance between the reference lines at the mid-point of the shoulder.

5.3 Gravimetric method

5.3.1 Principle

The dry-film thickness, t_d , in micrometres, is calculated from the difference between the mass of the uncoated specimen and that of the coated specimen using the following equation:

$$t_d = \frac{m - m_0}{A \cdot \rho_0} \quad (2)$$

where

- m_0 is the mass of the uncoated specimen, in grams;
- m is the mass of the coated specimen, in grams;
- A is the coated surface area, in square metres;
- ρ_0 is the density of the dry coating material applied, in grams per millilitre.

NOTE The dry-film density of the coating material can be determined in accordance with ISO 3233.

5.3.2 Field of application

The gravimetric method has general applicability.

5.3.3 General

Using the gravimetric method yields the mean value of the dry-film thickness over the entire coated surface area. With spray application in particular, the reverse side of the specimen shall be masked to prevent measurement errors resulting from partial coating of the reverse (overspray).

5.3.4 Method 5 — By difference in mass

5.3.4.1 Apparatus

Required are scales capable of weighing up to 500 g to the nearest 1 mg.

5.3.4.2 Procedure

Weigh the clean uncoated specimen, coat it, dry it and reweigh. Calculate the dry-film thickness using Equation (2).

5.4 Optical methods

5.4.1 Principle

In the cross-sectioning method (method 6A, see 5.4.4) the specimen is ground/cut along a plane normal to the coating so that the film thickness can be measured directly using a microscope (see Figure 11).

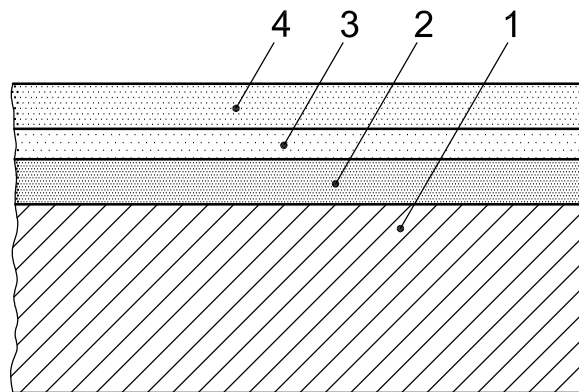

Key

- 1 substrate
- 2 coating 1
- 3 coating 2
- 4 coating 3

Figure 11 — Cross-sectioned specimen

With the wedge cut method (method 6B, see 5.4.5) a cut of defined dimensions is made in the coating using a cutting tool at a specified angle to the surface (see Figure 12). The film thickness, t , is calculated using the equation

$$t = b \cdot \tan \alpha \quad (3)$$

where

- b is the projected half-width of the cut (from the edge to the substrate), determined using a microscope;
- α is the angle of cut.

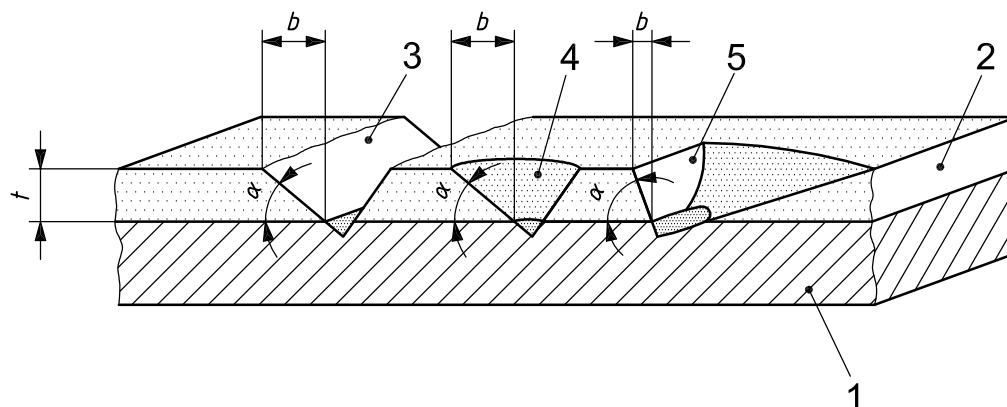

Key

- 1 substrate
- 2 coating
- 3 symmetrical cut
- 4 conical bore
- 5 sloping cut

Figure 12 — Symmetrical cut, conical bore and sloping cut

The symmetrical wedge cut (No. 3 in Figure 12) can be made in the coating using a special blade, the conical bore (No. 4 in Figure 12) by a special borer and the sloping cut (No. 5 in Figure 12) with a milling tool.

5.4.2 Field of application

The optical principle is basically suitable for all film-substrate combinations. The thicknesses of the individual layers in a multilayer coating can also be measured, provided the layers are sufficiently distinct from each other.

If the cross-sectioning or wedge cut method is used, the substrate will have to have the properties necessary for it to be sectioned, bored or cut.

In the event of a dispute, the cross-sectioning method (method 6A, see 5.4.4) is recognized as the referee method.

5.4.3 General

The specimen shall be flat for the wedge cut method (see, however, the Note to 5.4.5.2).

If the coating material is elastic, the cross-section/wedge cut can be so deformed that measurement gives invalid results. This effect may be reduced by cooling the specimen before making the cut.

In the event of a brittle and/or inadequately bonded coating, delamination of the film can make it difficult to determine the true interface between the coating and the substrate. There might, therefore, be an error in the readings.

5.4.4 Method 6A — Cross-sectioning

5.4.4.1 Version 1 — By grinding

5.4.4.1.1 Apparatus and materials

5.4.4.1.1.1 Grinding and polishing machine

Apparatus which is used for producing metallographic preparations is suitable.

5.4.4.1.1.2 Embedding medium

Use a cold-setting resin that has no deleterious effect on the paint coating and gives gap-free embedding.

5.4.4.1.1.3 Grinding and polishing media

Use waterproof abrasive paper, for example 280, 400 and 600 grit, or suitable grades of diamond paste or a similar paste.

5.4.4.1.1.4 Measuring microscope

Required is a microscope with a suitable illumination system giving optimum image contrast. The magnification shall be chosen such that the field of vision corresponds to 1,5 to 3 times the film thickness. The eyepiece or optoelectronic measurement device shall permit measurements to be made to an accuracy of at least 1 μm .

5.4.4.1.2 Procedure

Embed the specimen or a representative sample of the specimen in the resin (5.4.4.1.1.2). Wet-polish the specimen or sample using the grinding and polishing machine (5.4.4.1.1.1) along a plane normal to the coating surface. Repeat this process with an ever-finer grade of abrasive. Measure the thickness(es) of the exposed layer(s) using the microscope.

5.4.4.2 Version 2 — By cutting

5.4.4.2.1 Apparatus

5.4.4.2.1.1 Cutter

Required is a traversing or rotary microtome with carbide blades of suitable geometry and a holder for clamping the specimen in place.

5.4.4.2.1.2 Measuring microscope

Required is a microscope with a suitable illumination system giving optimum image contrast. The magnification shall be chosen such that the field of vision corresponds to 1,5 to 3 times the film thickness. The eyepiece or optoelectronic measurement device shall permit measurements to be made to an accuracy of at least 1 μm .

5.4.4.2.2 Procedure

Clamp the specimen or a representative sample taken from the specimen in the microtome specimen holder and cut along a plane normal to the coating surface. Measure the thicknesses of the exposed layers using the microscope.

5.4.5 Method 6B — Wedge cut

5.4.5.1 Apparatus

5.4.5.1.1 General

A cutter and a measuring microscope are required for the wedge cut method. These can both be incorporated in a single instrument.

5.4.5.1.2 Cutter

Required is a special instrument with a replaceable cutting tool for producing precise cuts at the specified angle.

The cutting tool (cutting blade, special paint borer or milling tool) shall

- be made of a carbide material;
- have precisely ground cutter flanks;
- be of suitable geometry to ensure accurate wedge cuts.

Standard cutting angles are in the range $\alpha = 5,7^\circ$ ($\tan\alpha = 0,1$) to $\alpha = 45^\circ$ ($\tan\alpha = 1$).

5.4.5.1.3 Measuring microscope

Required is a microscope with approximately $\times 50$ magnification and an illumination device. The eyepiece shall permit measurements to be made to the nearest 20 μm .

5.4.5.2 Procedure

Mark the specimen with, for example, a felt-tip pen in a contrasting colour in the measurement area. Make the cut or bore through this mark. The cut or bore shall penetrate into the substrate. Using the mark to locate the cut or bore with the microscope, measure the projected half-width, b , and calculate the film thickness(es) using Equation (3) (see 5.4.1).

NOTE Equation (3) cannot be used with curved surfaces. A modified calculation formula can be used for conical bores in curved surfaces, however.

5.5 Magnetic methods

5.5.1 General

With most magnetic-type dry-film thickness gauges, it is imperative that they are checked prior to readings being taken. Verification in accordance with the manufacturer's instructions shall be carried out within the range of thicknesses expected for the coating.

5.5.2 Principle

The film thickness is determined from the interaction between a magnetic field and the metallic substrate. The film thickness is determined from the force required to remove a magnet from the coating (method 7A, see 5.5.5), or from changes in the magnetic field (methods 7B, 7C and 7D, see 5.5.6, 5.5.7 and 5.5.8).

5.5.3 Field of application

Magnetic methods are suitable for coatings on metal substrates.

For methods 7A, 7B and 7C, the substrate must be ferromagnetic, and for method 7D non-ferromagnetic.

The properties of the coating shall be such that the reading is not rendered invalid when the instrument touches the coating surface.

5.5.4 General

The magnetic field produced by the instrument can be affected by the following factors:

- the geometry of the substrate (dimensions, curvature and thickness);
- the properties of the substrate material (e.g. permeability, conductivity and properties resulting from any pretreatment);
- the roughness of the substrate;
- other magnetic fields (residual magnetism of the substrate and external magnetic fields).

5.5.5 Method 7A — Magnetic pull-off gauge

5.5.5.1 Description of instrument

This instrument contains a magnet for determining the film thickness from the force of attraction between the magnet and the substrate [see Figures 13a) and 13b)].

NOTE The instrument shown in Figure 13a) can be used in any position. The instrument shown in Figure 13b) is designed for use only in one orientation because of the effect of gravity.

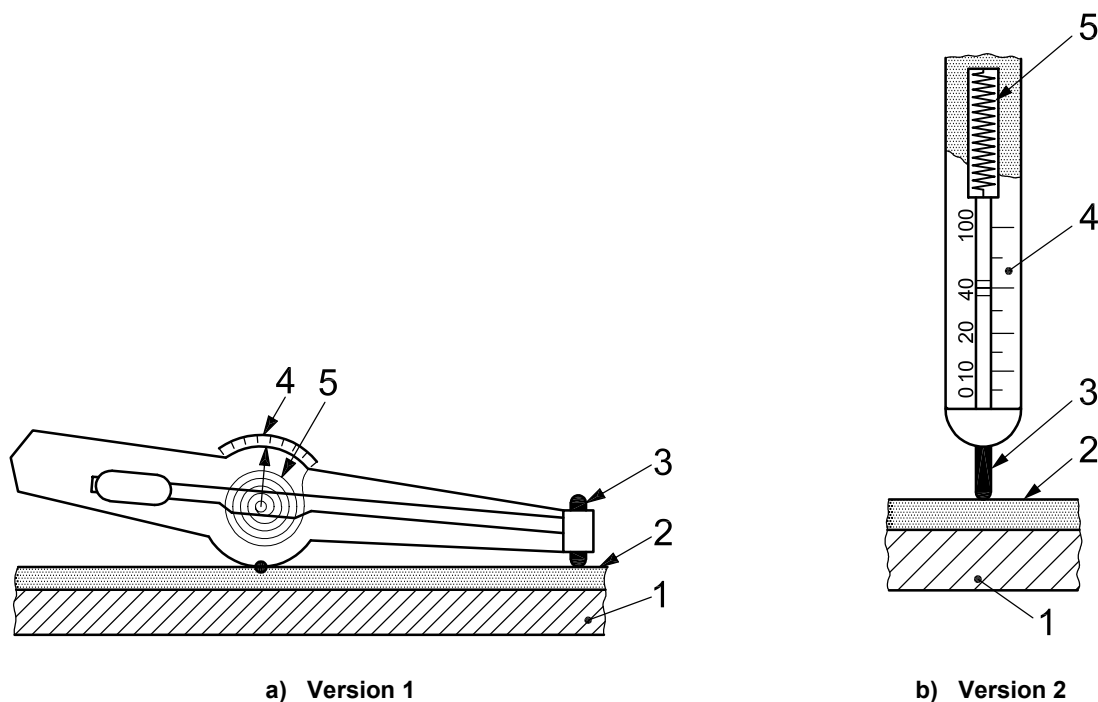

Key

- 1 substrate
- 2 coating
- 3 magnet
- 4 scale
- 5 spring

Figure 13 — Magnetic pull-off gauge

5.5.5.2 Procedure

Place the instrument with the magnet against the coating. Lift the magnet away from the coating in a direction perpendicular to the coating surface. The film thickness is derived from the force required to remove the magnet from the specimen.

5.5.6 Method 7B — Magnetic-flux gauge

5.5.6.1 Description of instrument

This instrument contains a magnet for determining the film thickness from the change, caused by the substrate, in the magnetic field of the magnet. The magnetic field is measured with a Hall probe (see Figure 14).

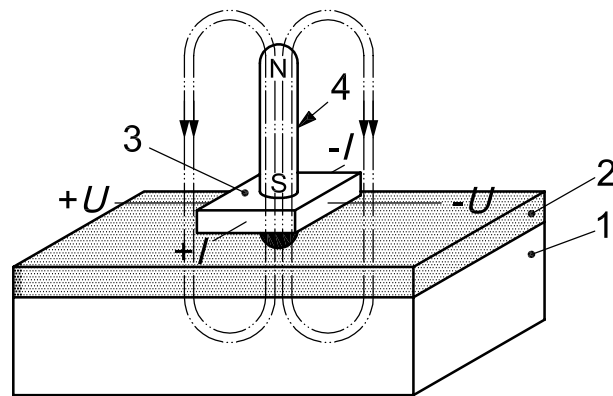

Key

- 1 substrate
- 2 coating
- 3 Hall element
- 4 magnet
- U Hall voltage
- I control current

Figure 14 — Hall probe

5.5.6.2 Procedure

Place the instrument on the coating so that it is perpendicular to the coating. Read the thickness directly from the dial or calculate it in accordance with the manufacturer's instructions.

5.5.7 Method 7C — Magnetic-induction gauge

5.5.7.1 Description of instrument

This instrument contains an electromagnet for determining the film thickness from the change produced in the magnetic field when it approaches a ferromagnetic substrate (see Figure 15). A low-frequency (LF, e.g. 60 Hz to 400 Hz) alternating electromagnetic field is generated by the electromagnet (see ISO 2178 [3]).

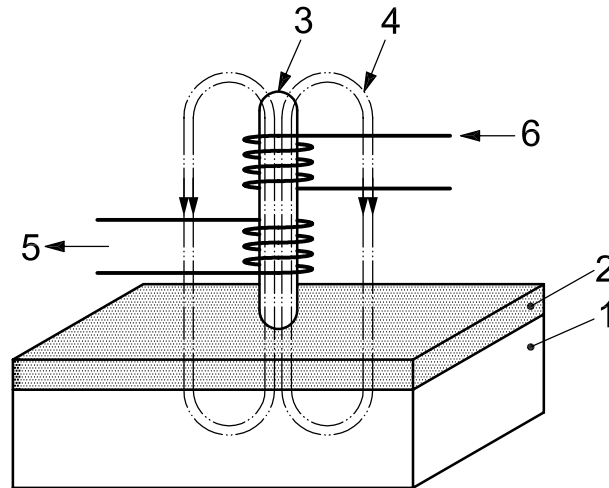
**Key**

- 1 substrate
- 2 coating
- 3 ferromagnetic core
- 4 alternating magnetic field (LF)
- 5 measurement signal
- 6 current

Figure 15 — Principle of magnetic-induction gauge

5.5.7.2 Procedure

Place the instrument on the coating so that it is perpendicular to the coating. Calculate the film thickness from the change in the magnetic flux.

5.5.8 Method 7D — Eddy-current gauge**5.5.8.1 Description of instrument**

This instrument contains an electromagnet for determining the film thickness from the change in the magnetic field caused by eddy currents in the electrically conductive substrate (see Figure 16). A high-frequency (HF, e.g. 0,1 MHz to 30 MHz) alternating electromagnetic field is generated in the electromagnet (see ISO 2360 [4]).

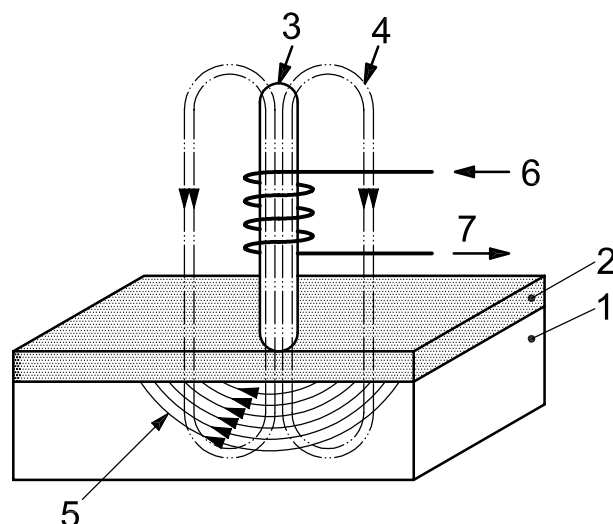
**Key**

- 1 substrate
- 2 coating
- 3 ferrite core
- 4 alternating magnetic field (HF)
- 5 eddy currents
- 6 current
- 7 measurement signal

Figure 16 — Principle of eddy-current gauge

5.5.8.2 Procedure

Place the instrument on the coating so that it is perpendicular to the coating.

5.6 Radiological method**5.6.1 Principle**

The film thickness is derived from the interaction between ionizing radiation and the coating. A radioisotope is used as the radiation source.

5.6.2 Field of application

The radiological principle is suitable for any film-substrate combination, provided the difference between the atomic number of the coating material and that of the substrate is at least 5 (see ISO 3543^[10]).

5.6.3 General

Measurement of the film thickness can be affected by

- the geometry of the substrate (dimensions, curvature);
- impurities at the surface of the coating;
- variations in the coating density.

5.6.4 Method 8 — Beta backscatter method

5.6.4.1 Description of instrument

The beta backscatter apparatus (see Figure 17) consists of

- a radiation source (radioisotope) which emits mainly beta particles having an energy appropriate to the film thickness to be measured;
- a probe or measurement system with a range of apertures and containing a beta detector to count the number of backscattered beta particles (e.g. a Geiger counter);
- a data-processing and display system.

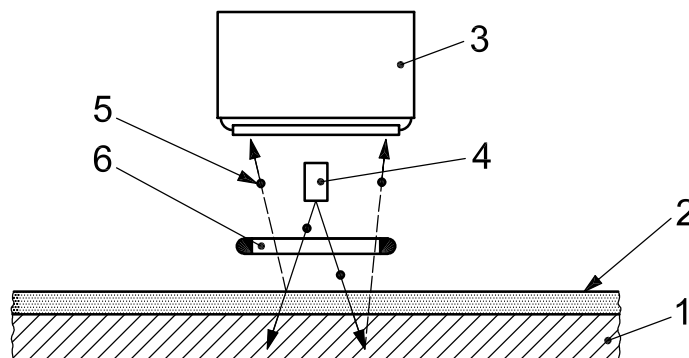

Key

- 1 substrate
- 2 coating
- 3 counter
- 4 radioisotope
- 5 backscattered particles
- 6 aperture

Figure 17 — Beta backscatter method

5.6.4.2 Verification

Verify and, if necessary, adjust the instrument with standards having as far as possible a coating and substrate of the same composition as the specimen to be examined.

5.6.4.3 Procedure

Operate the instrument in accordance with the manufacturer's instructions.

5.7 Photothermal method

5.7.1 Principle

The film thickness is determined from the difference between the time a thermal wave is radiated towards the coating and the time the re-emitted wave (either heat or ultrasonic) is detected (see Figure 18).

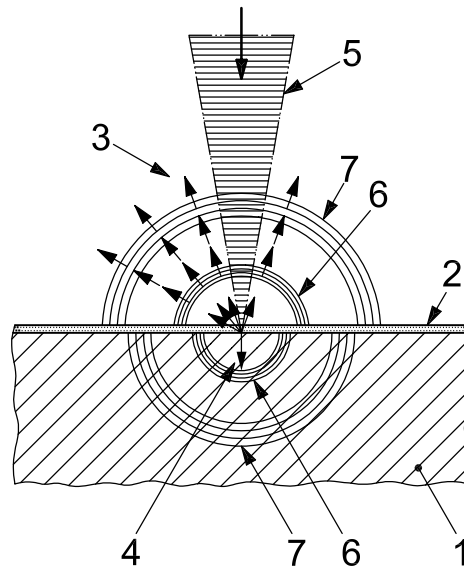

Key

- 1 substrate
- 2 coating
- 3 re-emitted thermal radiation
- 4 absorption of radiation by coating (depends on coating thickness and coating material)
- 5 thermal irradiation
- 6 thermal waves
- 7 ultrasonic waves

Figure 18 — Interaction of radiation with the specimen in photothermal thickness measurement

Irrespective of the type of excitation involved or the method of detection, all photothermal methods use the same principle: the periodic or pulsed introduction of energy in the form of heat into a specimen and the subsequent detection of the local temperature increase.

The time difference measured is compared against values obtained with the instrument for films of known thickness under fixed conditions (excitation energy, pulse length, excitation frequency, etc.) (see 5.7.4.2).

5.7.2 Field of application

The photothermal principle is basically suitable for all film-substrate combinations. It can also be used to determine the thicknesses of the individual layers in a multilayer coating, provided the layers are sufficiently distinct from each other with respect to their thermal conductivity and reflection properties.

The required minimum substrate thickness is a function of the measurement system used (see 5.7.4.1.1) and the film-substrate combination.

5.7.3 General

Classification of the method as destructive or non-destructive depends on the purpose of the coating. The thermal energy absorbed by the coating could have an impact on the coating owing to the local heating effect produced.

5.7.4 Method 9 — Determination using thermal properties

5.7.4.1 Instrument and reference standards

5.7.4.1.1 Measurement system

There are various methods for producing thermal waves in a coating material and for detecting the thermal effects induced at the heated location in the specimen (see EN 15042-2 ^[18]). Thermal radiation sources (e.g. laser sources, light-emitting diodes, incandescent light sources) are mainly used as the excitation system for paint coatings.

The following detection methods are used:

- detection of the re-emitted thermal radiation (photothermal radiometry);
- detection of the change in refractive index (in the heated air above the measurement area);
- pyroelectric detection (heat flow measurement).

5.7.4.1.2 Reference standards

Reference specimens with different absorption properties and a range of film thicknesses are required for verification purposes (see EN 15042-2 ^[18]).

5.7.4.2 Verification

Verify and, if necessary, adjust the measurement system with the reference specimens (see 5.7.4.1.2) for each film-substrate combination (in particular for each coating material).

5.7.4.3 Procedure

Operate the instrument in accordance with the manufacturer's instructions. Read the thickness directly from the display or calculate it in accordance with the manufacturer's instructions.

5.8 Acoustic method

5.8.1 Principle

In the acoustic method, the film thickness is determined from the propagation time of an ultrasonic pulse through the coating.

5.8.2 Field of application

The acoustic principle is suitable for any film-substrate combination.

The sound velocity shall be uniform in the individual coats and shall differ markedly from the sound velocity in the adjacent coat and in the substrate.

NOTE Inhomogeneities in the coating (e.g. the presence of aluminium flakes) and in the substrate (e.g. the grain in wood) can influence the result.

5.8.3 General

The acoustic field can be affected by the geometry of the substrate (dimensions, curvature and roughness).

5.8.4 Method 10 — Ultrasonic thickness gauge

5.8.4.1 Description of instrument

This instrument has an ultrasonic transmitter and a receiver for determining the film thickness from the sound propagation time (see Figure 19).

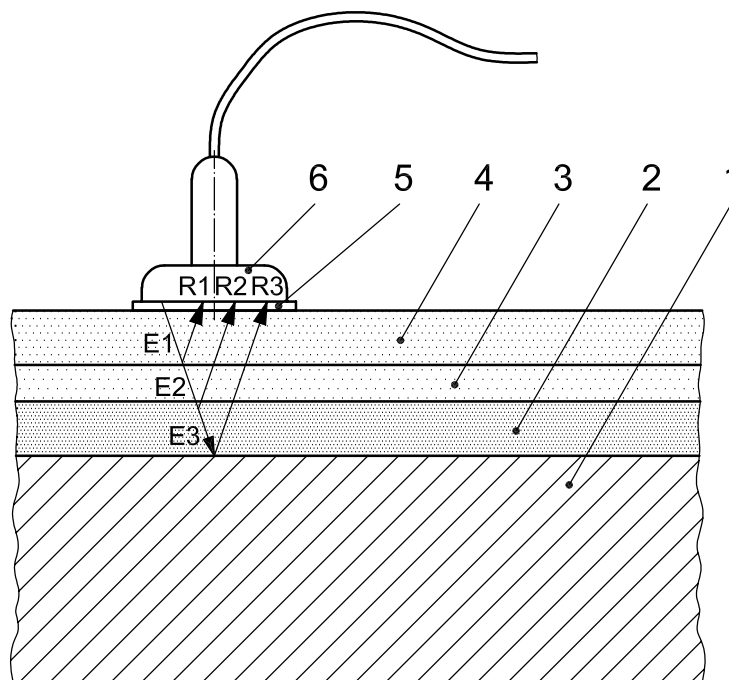

Key

- 1 substrate
- 2 coating 1
- 3 coating 2
- 4 coating 3
- 5 couplant
- 6 probe (transmitter and receiver)
- E pulse penetrating into coating
- R reflected pulses

Figure 19 — Ultrasonic thickness gauge

5.8.4.2 Procedure

Apply a couplant to the coating whose thickness is to be measured. Place the instrument with the probe face flat on the coating. Operate the instrument and determine the results in accordance with the manufacturer's instructions.

6 Determination of thickness of uncured powder layers

6.1 General

Annex A gives an overview of the methods used for determination of the thickness of uncured powder layers.

6.2 Gravimetric method

6.2.1 Principle

The film thickness of the uncured powder layer, t_p , in micrometres is calculated from the difference between the mass of the uncoated specimen and that of the coated specimen using the following equation:

$$t_p = \frac{m - m_0}{A \cdot \rho_p} \quad (4)$$

where

m_0 is the mass of the uncoated specimen, in grams;

m is the mass of the coated specimen, in grams;

A is the coated surface area, in square metres;

ρ_p is the density of the uncured powder coating material applied, in grams per millilitre.

NOTE The density of the powder coating material can be determined in accordance with ISO 8130-2 or ISO 8130-3.

6.2.2 Field of application

The gravimetric method has general applicability.

6.2.3 General

Using the gravimetric method yields the mean value of the film thickness over the entire coated surface area. When applying the powder, the reverse side of the specimen shall be masked to prevent measurement errors resulting from partial coating of the reverse (overspray).

6.2.4 Method 11 — By difference in mass

6.2.4.1 Apparatus

Required are scales capable of weighing up to 500 g to the nearest 1 mg.

6.2.4.2 Procedure

Weigh the clean uncoated specimen, coat it and reweigh. Calculate the film thickness using Equation (4).

The second weighing shall be carried out immediately after powder application.

6.3 Magnetic methods

6.3.1 Principle

The film thickness is determined from the interaction between a magnetic field and the metallic substrate. The film thickness is derived from the change in the magnetic field.

6.3.2 Field of application

Magnetic methods are suitable for coated metal substrates.

For method 12A, the substrate must be ferromagnetic, and for method 12B non-ferromagnetic.

6.3.3 General

The magnetic field produced by the instrument can be affected by the following factors:

- the geometry of the substrate (dimensions, thickness);
- the properties of the substrate material (e.g. permeability, conductivity and properties resulting from any pretreatment);
- the roughness of the substrate;
- other magnetic fields (residual magnetism of the substrate and external magnetic fields).

Only measurements on flat surfaces are permissible.

6.3.4 Method 12A — Magnetic-induction gauge

6.3.4.1 Description of instrument

This instrument contains an electromagnet for determining the film thickness from the change produced in the magnetic field when it approaches a ferromagnetic substrate (see Figure 20). A low-frequency (LF, e.g. 60 Hz to 400 Hz) alternating electromagnetic field is generated by the electromagnet (see ISO 2178^[3]).

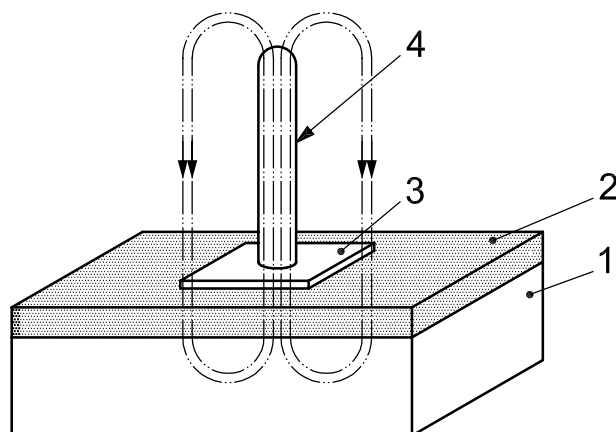

Key

- 1 substrate
- 2 coating
- 3 baseplate
- 4 magnet or eddy current probe

Figure 20 — Probe of magnetic-induction gauge for powder coating thickness measurements

The influence of the probe on the thickness of the uncured powder layer shall be kept to a minimum when positioning the probe.

6.3.4.2 Procedure

Place the instrument on the coating so that it is perpendicular to the coating. Read the thickness directly from the display or calculate it in accordance with the manufacturer's instructions.

6.3.5 Method 12B — Eddy-current gauge

6.3.5.1 Description of instrument

This instrument contains an electromagnet for determining the film thickness from the change in the magnetic field caused by eddy currents in the electrically conductive substrate (see Figure 16). A high-frequency (HF, e.g. 0,1 MHz to 30 MHz) alternating electromagnetic field is generated in the electromagnet (see ISO 2360 [4]).

The influence of the probe on the film thickness of the uncured powder layer shall be kept to a minimum when positioning the probe.

6.3.5.2 Procedure

Place the instrument on the coating so that it is perpendicular to the coating. Read the thickness directly from the display or calculate it in accordance with the manufacturer's instructions.

6.4 Photothermal method

6.4.1 Principle

The film thickness is determined from the difference between the time a thermal wave is radiated towards the coating and the time the re-emitted wave (either heat or ultrasonic) is detected (see Figure 18).

Irrespective of the type of excitation involved or the method of detection, all photothermal methods use the same principle: the periodic or pulsed introduction of energy in the form of heat into a specimen and the subsequent detection of the local temperature increase.

The time difference measured is compared against values obtained with the instrument for films of known thickness under fixed conditions (excitation energy, pulse length, excitation frequency, etc.) (see 6.4.4.2).

6.4.2 Field of application

The photothermal principle is basically suitable for all film-substrate combinations. It can also be used to determine the thicknesses of the individual layers in a multilayer coating, provided the layers are sufficiently distinct from each other with respect to their thermal conductivity and reflection properties.

The required minimum substrate thickness is a function of the measurement system used (see 6.4.4.1.1) and the film-substrate combination.

6.4.3 General

Classification of the method as destructive or non-destructive depends on the purpose of the coating. The thermal energy absorbed by the coating could have an impact on the coating owing to the local heating effect produced.

6.4.4 Method 13 — Determination using thermal properties

6.4.4.1 Instrument and reference standards

6.4.4.1.1 Measurement system

There are various methods for producing thermal waves in a coating material and for detecting the thermal effects induced at the heated location in the specimen (see EN 15042-2 [18]). Thermal radiation sources (e.g. laser sources, light-emitting diodes, incandescent light sources) are mainly used as the excitation system for paint coatings.

The following detection methods are used:

- detection of the re-emitted thermal radiation (photothermal radiometry);
- detection of the change in refractive index (in the heated air above the measurement area);
- pyroelectric detection (heat flow measurement).

6.4.4.1.2 Reference standards

Reference specimens with different absorption properties and a range of film thicknesses are required for verification purposes (see EN 15042-2^[18]).

6.4.4.2 Verification

Verify and, if necessary, adjust the measurement system using the reference specimens (see 6.4.4.1.2) for each film-substrate combination (particularly for each film material).

6.4.4.3 Procedure

Operate the instrument in accordance with the manufacturer's instructions. Read the thickness directly from the display or calculate it in accordance with the manufacturer's instructions.

7 Measurement of film thickness on rough surfaces

7.1 General

The surface roughness of a substrate influences the result of a film thickness determination. For blast-cleaned steel substrates, therefore, special considerations apply. If a coating is applied to a blast-cleaned steel substrate, the measurement of its thickness is more complicated than for smooth surfaces. The results are influenced by the properties of the substrate, which vary from point to point, and by the design of the measurement equipment. The procedure used to set up instruments on blast-cleaned substrates has in practice led to significant variability in the dry-film thickness readings.

In addition to the variation of results with the type of instrument used, zeroing an instrument on a blast-cleaned surface also introduces problems, such as:

- poor repeatability;
- variability in the measured thickness of a shim placed on such a surface (the thicker the shim the greater the apparent increase in shim thickness);
- the uncertainty involved when the surface roughness of the steel substrate is not known.

The object of the method described in this clause is to minimize variability and achieve uniformity of practice in the measurement of the thickness of coatings on blast-cleaned steel surfaces. The method entails the measurement of film thickness using an instrument of the magnetic-induction type previously zeroed on a smooth steel surface.

This method measures the coating thickness from an imaginary plane located between the peaks and the troughs of the rough surface of the substrate, typically about 25 µm below the peaks (i.e. about half of the surface roughness, expressed as the height from the bottom to the top of the peaks, of the blast-cleaned surface) except for surfaces prepared to a surface profile grading of "fine" as defined in ISO 8503-1.

The method describes the determination of a parameter representative of the thickness of a dried coating on a blast-cleaned steel substrate. The actual film thickness, as measured by a reference method, shall not be less than 25 µm and should preferably be greater than 50 µm for the results to be meaningful.

Other methods for determining the thicknesses of coatings on rough surfaces are described in ISO 19840 [14].

7.2 Apparatus and materials

7.2.1 Film thickness measuring instrument, of the magnetic-induction type, as used in method 7C (see 5.5.7).

NOTE Equipment fitted with facilities for calculating the mean standard deviation of measurements and other statistical parameters should be used with caution and preferably only by those trained in statistical techniques.

7.2.2 Verification shims, of the foil type, with assigned values traceable to nationally recognized standards, of thickness near to the expected film thickness.

NOTE The use of uncertified shims is permitted provided they are verified on site.

7.2.3 Smooth steel plate, free of mill scale and rust, similar in magnetic nature to the coated steel and at least 1,2 mm thick, for use in verifying the instrument.

7.3 Procedure

7.3.1 Verification

Before use, verify and, if necessary, adjust the instrument in accordance with the manufacturer's instructions for steel, using the smooth steel plate, which shall be polished with 400 grit abrasive paper to remove all staining and corrosion products before use. The verification shims shall be placed between the probe and the smooth steel plate. Verification shims of thicknesses above and below the expected film thickness shall be used.

7.3.2 Measurement

Measurements on the dry coating shall be made in accordance with the instrument manufacturer's instructions for smooth steel. For the number of readings, see 7.3.3.

7.3.3 Number of readings

It is advisable to take at least three readings evenly spread in each test area.

As a guide, it is recommended that there be two test areas every square metre for flat plates, four every metre length for webs, two every metre length for flanges and two or more every metre length for pipes (depending on pipe diameter).

It is generally recommended that, for off-shore and other marine work, more readings are taken.

8 Test report

The test report shall include the following information:

- a) all information necessary for identification of the product tested (manufacturer, product designation, batch number, etc.);
- b) reference to this International Standard, i.e. ISO 2808:2007;

EN ISO 2808:2007

- c) the method and instrument used;
- d) the results of the test, including the results of the individual determinations and their mean;
- e) any deviations from the procedure specified;
- f) any unusual features (anomalies) observed during the test;
- g) the date of the test.

The test report may also contain the following additional information, if necessary:

- h) details of the substrate (material, thickness, pretreatment);
- i) the method used to coat the substrate and whether it was a single-coat or a multi-coat system;
- j) the length of time and conditions used for drying/curing (including stoving) of the coating and, if necessary, details of any ageing carried out before making the thickness measurements;
- k) the relevant surface area, the test areas and the number of measurement areas per test area;
- l) the mean film thickness and its standard deviation, the local film thickness and its standard deviation, and the minimum and maximum local film thickness.

Annex A (informative)

Overview of methods

An overview of the methods described in this International Standard is given in Tables A.1 to A.3. The field of application, existing standards and the precision are specified for the individual methods. Where standards exist for individual methods, reference is made to these.

Table A.1 — Determination of wet-film thickness

Principle	Method	Substrate ^a	Field of application ^b			Standard ^c	Accuracy/precision ^d
			nd/d ^e	c	l/p/f		
Mechanical (4.2)	1A Comb gauge (4.2.4)	X	nd/d ^e	c	l/p/f	ASTM D 4414	Systematic error of precision comb gauge $\pm 10\%$ or $\pm 5\ \mu\text{m}$, whichever is higher
	1B Wheel gauge (4.2.5)	X	nd/d ^e	c	l/p/f	ASTM D 1212	Systematic error $\pm 5\%$ or $\pm 5\ \mu\text{m}$, whichever is higher
	1C Dial gauge (4.2.6)	X	nd/d ^e	c	l/p/f		Systematic error $\pm 5\%$ or $\pm 3\ \mu\text{m}$, whichever is higher
Gravimetric (4.3)	2 By difference in mass (4.3.4)	X	nd	nc	l		No data available
Photothermal (4.4)	3 Thermal properties (4.4.4)	X	nd	nc	l/p	EN 15042-2	Systematic error $\pm 2\%$ or $\pm 3\ \mu\text{m}$, whichever is higher

^a X = any substrate

^b d = destructive
nd = non-destructive
c = contact
nc = non-contact

l/p/f = applicable to laboratory/production/field work

^c Representative (inter)national standards in which the methods are described.

^d Accuracy data for these methods are made available by the instrument manufacturers and can be verified with traceable calibration standards. The figures given are based on empirical values given by the instrument manufacturers and by users. Variations are possible.

^e Depends on the coating and the function of the coating.

Table A.2 — Determination of dry-film thickness

Principle	Method	Substrate ^a	Field of application ^b			Standard ^c	Accuracy/precision ^d
			nd/d ^e	c	l		
Mechanical (5.2)	4A Difference in thickness (micrometer/dial gauge) (5.2.4)	X	nd/d ^e	c	l	ASTM D 1005 DIN 50933	Mechanical: lower limit 5 µm Electronic: lower limit 3 µm
	4B Depth gauging (micrometer/dial gauge) (5.2.5)	X	d	c	l		Mechanical: lower limit 3 µm Electronic: lower limit 2 µm
	4C Surface profile scanning (5.2.6)	X	d	nc	l	ISO 4518	Lower limit: 2 µm
Gravimetric (5.3)	5 By difference in mass (5.3.4)	X	d	c	l/p/f		No data available.
Optical (5.4)	6A Cross-sectioning (5.4.4)	X	d	c	l	ISO 1463	Systematic error ± 2 µm Reproducibility ± 5 %
	6B Wedge cut (5.4.5)	X	d	c	l/p/f	DIN 50986	With the upper limit 2 µm Reproducibility ± 10 %
Magnetic (5.5)	7A Magnetic pull-off gauge (5.5.5)	Fe	nd	c	l/p/f	ISO 2178	Systematic error ± 5 µm Reproducibility ± 6 %
	7B Magnetic-flux gauge (5.5.6)	Fe	nd	c	l/p/f		Systematic error ± 3 µm Reproducibility ± 5 %
	7C Magnetic-induction gauge (5.5.7)	Fe	nd	c	l/p/f	ISO 2178	Systematic error ± 2 µm Reproducibility ± 3 %
	7D Eddy-current gauge (5.5.8)	NFe	nd	c	l/p/f	ISO 2360	Systematic error ± 2 µm Reproducibility ± 3 %
Radiological (5.6)	8 Beta backscattering (5.6.4)	X	nd	nc	l/p	ISO 3543	Systematic error ± 2 % or ± 0,5 µm, whichever is higher
Photothermal (5.7)	9 Thermal properties (5.7.4)	X	nd	nc	l/p	EN 15042-2	No data available
Acoustic (5.8)	10 Ultrasonic thickness gauge (5.8.4)	X	nd	c	l/p/f		Systematic error ± 2 µm Reproducibility ± 5 %

^a X/Fe/NFe = any/ferromagnetic metal/non-ferromagnetic metal

^b d = destructive

nd = non-destructive

c = contact

nc = non-contact

l/p/f = applicable to laboratory/production/field work

^c Representative (inter)national standards in which the methods are described.

^d Accuracy data for these methods are made available by the instrument manufacturers and can be verified with traceable calibration standards. The figures given are based on empirical values given by the instrument manufacturers and by users. Variations are possible.

^e Depends on the procedure.

Table A.3 — Determination of the film thickness of non-cross-linked powders

Principle	Method	Substrate ^a	Field of application ^b			Standard ^c	Accuracy/precision ^d
			nd	nc	l		
Gravimetric (6.2)	11 By difference in mass (6.2.4)	X	nd	nc	l		No data available.
Magnetic (6.3)	12A Magnetic-induction gauge (6.3.4)	Fe	nd/d ^e	c	l/p	ISO 2178	Systematic error $\pm 2 \mu\text{m}$ Reproducibility $\pm 3 \%$
	12B Eddy-current gauge (6.3.5)	NFe	nd/d ^e	c	l/p	ISO 2360	Systematic error $\pm 2 \mu\text{m}$ Reproducibility $\pm 3 \%$
Photothermal (6.4)	13 Thermal properties (6.4.4)	X	nd/d ^e	nc	l/p	EN 15042-2	Systematic error $\pm 2 \%$ or $\pm 3 \mu\text{m}$, whichever is higher

^a X/Fe/NFe = any/ferromagnetic metal/non-ferromagnetic metal

^b d = destructive
nd = non-destructive
c = contact
nc = non-contact
l/p/f = applicable to laboratory/production/field work

^c Representative (inter)national standards in which the methods are described.

^d Accuracy data for these methods are made available by the instrument manufacturers and can be verified with traceable calibration standards. The figures given are based on empirical values given by the instrument manufacturers and by users. Variations are possible.

^e Depends on the procedure.

Bibliography

- [1] ISO 1101, *Geometrical Product Specifications (GPS) — Geometrical tolerancing — Tolerances of form, orientation, location and run-out*
- [2] ISO 1463, *Metallic and oxide coatings — Measurement of coating thickness — Microscopical method*
- [3] ISO 2178, *Non-magnetic coatings on magnetic substrates — Measurement of coating thickness — Magnetic method*
- [4] ISO 2360, *Non-conductive coatings on non-magnetic electrically conductive basis materials — Measurement of coating thickness — Amplitude-sensitive eddy-current method*
- [5] ISO 2811-1, *Paints and varnishes — Determination of density — Part 1: Pycnometer method*
- [6] ISO 2811-2, *Paints and varnishes — Determination of density — Part 2: Immersed body (plummet) method*
- [7] ISO 2811-3, *Paints and varnishes — Determination of density — Part 3: Oscillation method*
- [8] ISO 2811-4, *Paints and varnishes — Determination of density — Part 4: Pressure cup method*
- [9] ISO 3233, *Paints and varnishes — Determination of percentage volume of non-volatile matter by measuring the density of a dried coating*
- [10] ISO 3543, *Metallic and non-metallic coatings — Measurement of thickness — Beta backscatter method*
- [11] ISO 4518, *Metallic coatings — Measurement of coating thickness — Profilometric method*
- [12] ISO 8130-2, *Coating powders — Part 2: Determination of density by gas comparison pycnometer (referee method)*
- [13] ISO 8130-3, *Coating powders — Part 3: Determination of density by liquid displacement pycnometer*
- [14] ISO 19840, *Paints and varnishes — Corrosion protection of steel structures by protective paint systems — Measurement of, and acceptance criteria for, the thickness of dry films on rough surfaces*
- [15] ASTM D 1005, *Standard Test Method for Measurement of Dry Film Thickness of Organic Coatings Using Micrometers*
- [16] ASTM D 1212, *Standard Test Methods for Measurement of Wet Film Thickness of Organic Coatings*
- [17] ASTM D 4414, *Standard Practice for Measurement of Wet Film thickness by Notch Gages*
- [18] EN 15042-2, *Thickness measurement of coatings and characterization of surfaces with surface waves — Part 2: Guide to the thickness measurement of coatings by photothermic method*
- [19] DIN 50933, *Measurement of coating thickness by differential measurement using a stylus instrument*
- [20] DIN 50986, *Measurement of coating thickness — Wedge cut method for measuring the thickness of paints and related coatings*

BSI — British Standards Institution

BSI is the independent national body responsible for preparing British Standards. It presents the UK view on standards in Europe and at the international level. It is incorporated by Royal Charter.

Revisions

British Standards are updated by amendment or revision. Users of British Standards should make sure that they possess the latest amendments or editions.

It is the constant aim of BSI to improve the quality of our products and services. We would be grateful if anyone finding an inaccuracy or ambiguity while using this British Standard would inform the Secretary of the technical committee responsible, the identity of which can be found on the inside front cover.
Tel: +44 (0)20 8996 9000. Fax: +44 (0)20 8996 7400.

BSI offers members an individual updating service called PLUS which ensures that subscribers automatically receive the latest editions of standards.

Buying standards

Orders for all BSI, international and foreign standards publications should be addressed to Customer Services. Tel: +44 (0)20 8996 9001.
Fax: +44 (0)20 8996 7001. Email: orders@bsi-global.com. Standards are also available from the BSI website at <http://www.bsi-global.com>.

In response to orders for international standards, it is BSI policy to supply the BSI implementation of those that have been published as British Standards, unless otherwise requested.

Information on standards

BSI provides a wide range of information on national, European and international standards through its Library and its Technical Help to Exporters Service. Various BSI electronic information services are also available which give details on all its products and services. Contact the Information Centre.
Tel: +44 (0)20 8996 7111. Fax: +44 (0)20 8996 7048. Email: info@bsi-global.com.

Subscribing members of BSI are kept up to date with standards developments and receive substantial discounts on the purchase price of standards. For details of these and other benefits contact Membership Administration.
Tel: +44 (0)20 8996 7002. Fax: +44 (0)20 8996 7001.
Email: membership@bsi-global.com.

Information regarding online access to British Standards via British Standards Online can be found at <http://www.bsi-global.com/bsonline>.

Further information about BSI is available on the BSI website at <http://www.bsi-global.com>.

Copyright

Copyright subsists in all BSI publications. BSI also holds the copyright, in the UK, of the publications of the international standardization bodies. Except as permitted under the Copyright, Designs and Patents Act 1988 no extract may be reproduced, stored in a retrieval system or transmitted in any form or by any means – electronic, photocopying, recording or otherwise – without prior written permission from BSI.

This does not preclude the free use, in the course of implementing the standard, of necessary details such as symbols, and size, type or grade designations. If these details are to be used for any other purpose than implementation then the prior written permission of BSI must be obtained.

Details and advice can be obtained from the Copyright & Licensing Manager.
Tel: +44 (0)20 8996 7070. Fax: +44 (0)20 8996 7553.
Email: copyright@bsi-global.com.