

BS EN ISO 2758:2014



BSI Standards Publication

# Paper — Determination of bursting strength

**bsi.**

...making excellence a habit.™

**National foreword**

This British Standard is the UK implementation of EN ISO 2758:2014. It supersedes BS EN ISO 2758:2003 which is withdrawn.

The UK participation in its preparation was entrusted to Technical Committee PAI/11, Methods of test for paper, board and pulps.

A list of organizations represented on this committee can be obtained on request to its secretary.

This publication does not purport to include all the necessary provisions of a contract. Users are responsible for its correct application.

© The British Standards Institution 2014. Published by BSI Standards Limited 2014

ISBN 978 0 580 78154 4

ICS 85.060

**Compliance with a British Standard cannot confer immunity from legal obligations.**

This British Standard was published under the authority of the Standards Policy and Strategy Committee on 31 August 2014.

**Amendments issued since publication**

Date	Text affected
------	---------------

---

English Version

**Paper - Determination of bursting strength (ISO 2758:2014)**

Papier - Détermination de la résistance à l'éclatement (ISO 2758:2014)

Papier - Bestimmung des Berstdruckes (ISO 2758:2014)

This European Standard was approved by CEN on 14 June 2014.

CEN members are bound to comply with the CEN/CENELEC Internal Regulations which stipulate the conditions for giving this European Standard the status of a national standard without any alteration. Up-to-date lists and bibliographical references concerning such national standards may be obtained on application to the CEN-CENELEC Management Centre or to any CEN member.

This European Standard exists in three official versions (English, French, German). A version in any other language made by translation under the responsibility of a CEN member into its own language and notified to the CEN-CENELEC Management Centre has the same status as the official versions.

CEN members are the national standards bodies of Austria, Belgium, Bulgaria, Croatia, Cyprus, Czech Republic, Denmark, Estonia, Finland, Former Yugoslav Republic of Macedonia, France, Germany, Greece, Hungary, Iceland, Ireland, Italy, Latvia, Lithuania, Luxembourg, Malta, Netherlands, Norway, Poland, Portugal, Romania, Slovakia, Slovenia, Spain, Sweden, Switzerland, Turkey and United Kingdom.



EUROPEAN COMMITTEE FOR STANDARDIZATION  
COMITÉ EUROPÉEN DE NORMALISATION  
EUROPÄISCHES KOMITEE FÜR NORMUNG

**CEN-CENELEC Management Centre: Avenue Marnix 17, B-1000 Brussels**

## Foreword

This document (EN ISO 2758:2014) has been prepared by Technical Committee ISO/TC 6 "Paper, board and pulps" in collaboration with Technical Committee CEN/TC 172 "Pulp, paper and board" the secretariat of which is held by DIN.

This European Standard shall be given the status of a national standard, either by publication of an identical text or by endorsement, at the latest by February 2015, and conflicting national standards shall be withdrawn at the latest by February 2015.

Attention is drawn to the possibility that some of the elements of this document may be the subject of patent rights. CEN [and/or CENELEC] shall not be held responsible for identifying any or all such patent rights.

This document supersedes EN ISO 2758:2003.

According to the CEN-CENELEC Internal Regulations, the national standards organizations of the following countries are bound to implement this European Standard: Austria, Belgium, Bulgaria, Croatia, Cyprus, Czech Republic, Denmark, Estonia, Finland, Former Yugoslav Republic of Macedonia, France, Germany, Greece, Hungary, Iceland, Ireland, Italy, Latvia, Lithuania, Luxembourg, Malta, Netherlands, Norway, Poland, Portugal, Romania, Slovakia, Slovenia, Spain, Sweden, Switzerland, Turkey and the United Kingdom.

### Endorsement notice

The text of ISO 2758:2014 has been approved by CEN as EN ISO 2758:2014 without any modification.

# Contents

Page

<b>Foreword</b> .....	<b>iv</b>
<b>Introduction</b> .....	<b>v</b>
<b>1 Scope</b> .....	<b>1</b>
<b>2 Normative references</b> .....	<b>1</b>
<b>3 Terms and definitions</b> .....	<b>1</b>
<b>4 Principle</b> .....	<b>1</b>
<b>5 Apparatus</b> .....	<b>1</b>
<b>6 Calibration</b> .....	<b>2</b>
<b>7 Sampling and preparation of test pieces</b> .....	<b>3</b>
<b>8 Procedure</b> .....	<b>3</b>
<b>9 Expression of results</b> .....	<b>4</b>
<b>10 Test report</b> .....	<b>4</b>
<b>Annex A (normative) Dimensions of the clamping system</b> .....	<b>5</b>
<b>Annex B (normative) Testing the clamps</b> .....	<b>7</b>
<b>Annex C (normative) Clamping pressure</b> .....	<b>8</b>
<b>Annex D (normative) Calibration of pressure-measuring system</b> .....	<b>9</b>
<b>Annex E (informative) Precision</b> .....	<b>10</b>
<b>Bibliography</b> .....	<b>12</b>

## Foreword

ISO (the International Organization for Standardization) is a worldwide federation of national standards bodies (ISO member bodies). The work of preparing International Standards is normally carried out through ISO technical committees. Each member body interested in a subject for which a technical committee has been established has the right to be represented on that committee. International organizations, governmental and non-governmental, in liaison with ISO, also take part in the work. ISO collaborates closely with the International Electrotechnical Commission (IEC) on all matters of electrotechnical standardization.

The procedures used to develop this document and those intended for its further maintenance are described in the ISO/IEC Directives, Part 1. In particular the different approval criteria needed for the different types of ISO documents should be noted. This document was drafted in accordance with the editorial rules of the ISO/IEC Directives, Part 2. [www.iso.org/directives](http://www.iso.org/directives)

Attention is drawn to the possibility that some of the elements of this document may be the subject of patent rights. ISO shall not be held responsible for identifying any or all such patent rights. Details of any patent rights identified during the development of the document will be in the Introduction and/or on the ISO list of patent declarations received. [www.iso.org/patents](http://www.iso.org/patents)

Any trade name used in this document is information given for the convenience of users and does not constitute an endorsement.

For an explanation on the meaning of ISO specific terms and expressions related to conformity assessment, as well as information about ISO's adherence to the WTO principles in the Technical Barriers to Trade (TBT) see the following URL: [Foreword - Supplementary information](#)

The committee responsible for this document is ISO/TC 6, *Paper, board and pulps*, Subcommittee SC 2, *Test methods and quality specifications for paper and board*.

This fourth edition cancels and replaces the third edition (ISO 2758:2001), of which it constitutes a minor revision. It has been revised to include precision data.

## Introduction

This International Standard is applicable to papers with bursting strengths in the range 70 kPa to 1 400 kPa.

For materials with bursting strengths equal to or greater than 350 kPa (or 250 kPa for the components of combined materials), an alternative method, based on similar principles, is specified in ISO 2759<sup>[1]</sup>. All components of solid and corrugated fibreboard, irrespective of bursting strength, should be tested according to ISO 2759.

In view of the overlap between the method for testing papers and boards and in the absence of any commercial agreement, materials below 600 kPa should be tested according to this International Standard.

**NOTE** Due to differences in the specification of the apparatus, tests made on the same material using the procedures of ISO 2759 and this International Standard will not necessarily give the same results.





# Paper — Determination of bursting strength

## 1 Scope

This International Standard specifies a method for measuring the bursting strength of paper submitted to increasing hydraulic pressure. It is applicable to paper having bursting strengths within the range 70 kPa to 1 400 kPa. It is not intended to be used for the components (such as fluting medium or linerboard) of a combined board, for which the method given in ISO 2759<sup>[1]</sup> is more suitable.

In the absence of any commercial agreement as to which method should be used for testing the material, materials with bursting strengths below 600 kPa should be tested according to this International Standard.

## 2 Normative references

The following documents, in whole or in part, are normatively referenced in this document and are indispensable for its application. For dated references, only the edition cited applies. For undated references, the latest edition of the referenced document (including any amendments) applies.

ISO 186, *Paper and board — Sampling to determine average quality*

ISO 187, *Paper, board and pulps — Standard atmosphere for conditioning and testing and procedure for monitoring the atmosphere and conditioning of samples*

ISO 536, *Paper and board — Determination of grammage*

## 3 Terms and definitions

For the purposes of this document, the following terms and definitions apply.

### 3.1

#### **bursting strength**

maximum pressure developed by the hydraulic system in forcing an elastic diaphragm through a circular area of the paper when the pressure is applied in the manner described in the method

Note 1 to entry: The indicated bursting pressure includes the pressure required to extend the diaphragm during the test.

### 3.2

#### **burst index**

bursting strength of paper, in kilopascals, divided by the grammage of the paper determined in accordance with ISO 536

## 4 Principle

A test piece, placed over a circular elastic diaphragm, is rigidly clamped at the periphery but free to bulge with the diaphragm. Hydraulic fluid is pumped at a constant rate, bulging the diaphragm until the test piece ruptures. The bursting strength of the test piece is the maximum value of the applied hydraulic pressure.

## 5 Apparatus

The apparatus shall contain, as a minimum, the features described in [5.1](#) to [5.4](#).

**5.1 Clamping system**, for clamping the test piece firmly and uniformly between two annular, plane, parallel surfaces which shall be smooth (but not polished) and grooved as described in [Annex A](#), which also gives the dimensions of the clamping system.

One clamping plate shall be held in a swivel joint or similar device so as to ensure that the clamping pressure is distributed evenly.

Under the load used for testing, the circular openings in the two clamping faces shall be concentric to within 0,25 mm and the clamping surfaces shall be flat and parallel. The method of checking the clamps is given in [Annex B](#).

The clamping system shall be capable of applying a known clamping pressure up to 1 200 kPa and shall be constructed in such a way that repeatable clamping pressures can be obtained in use (see [Annex C](#)).

In calculating the clamping pressure, the reduction in area due to the grooves shall be ignored.

Any clamping-pressure-indicating device fitted should preferably be scaled to indicate the actual clamping pressure, not the pressure in the clamping system itself. The clamping pressure may be calculated from clamping-force and clamp-area information.

**5.2 Diaphragm**, circular, of natural or synthetic rubber, free from filler or loading and  $0,86 \text{ mm} \pm 0,06 \text{ mm}$  thick, clamped securely with its outer surface, when at rest, recessed about 3,5 mm relative to the outer plane of the diaphragm-mounting plate.

The material and construction of the diaphragm shall be such that the pressure required to bulge the diaphragm  $9,00 \text{ mm} \pm 0,2 \text{ mm}$  outside the outer plane of the diaphragm plate is  $30 \text{ kPa} \pm 5 \text{ kPa}$ . Diaphragms in use shall be regularly checked and changed if the bulge-height requirement is no longer met.

**5.3 Hydraulic system**, to apply an increasing hydraulic pressure to the inside of the diaphragm until the test piece bursts.

The pressure shall be generated by a motor-driven piston forcing a suitable liquid (e.g. pure glycerol, low viscosity silicone oil, ethylene glycol containing corrosion inhibitor) which is compatible with the diaphragm material against the inner surface of the diaphragm. The hydraulic system and the fluid used shall be free from air bubbles. The pumping rate shall be  $95 \text{ ml/min} \pm 5 \text{ ml/min}$ .

**5.4 Pressure-measuring system**, to measure bursting strength.

It may employ any principle which produces a measurement and display accuracy equal to  $\pm 10 \text{ kPa}$  or  $\pm 3 \%$  of the measurement, whichever is the greater. The rate of response to the rising hydraulic pressure shall be such that the indicated maximum pressure is within  $\pm 3 \%$  of the true peak pressure as determined by a calibration system of the type described in [Annex D](#).

## 6 Calibration

**6.1** The apparatus should be fitted, or able to be fitted, with suitable test points to facilitate checking of the fluid pumping rate, calibration of the maximum pressure-measurement and display system and calibration of the clamping-pressure-indicating device where fitted.

**6.2** Calibration shall be carried out before initial use and at sufficiently frequent intervals to maintain the specified accuracy. Wherever possible, calibration of the pressure-sensing device should be carried out with it mounted in the same position it occupies on the apparatus and preferably on the apparatus itself.

If a pressure sensor is accidentally subjected to pressure beyond its rated capacity, it shall be recalibrated before further use.

Aluminium foils of various thicknesses may be available for use as test pieces of known burst value. Such devices are a useful means of checking the overall function of an instrument but, since the behaviour of foil under stress is unlike that of paper, they should not be used as calibration standards.

## 7 Sampling and preparation of test pieces

The sampling procedure is not covered by this International Standard. Make sure that the test pieces taken for the determination are representative of the sample received. If the determination is to represent a lot of paper, the sampling procedure shall be carried out in accordance with ISO 186. Where possible, test pieces shall not include areas containing watermarks, creases or visible damage.

Test pieces shall be conditioned in accordance with ISO 187.

The number of test pieces required depends on whether or not separate results are required for burst tests carried out with each surface in contact with the diaphragm.

## 8 Procedure

Tests shall be carried out in the standard atmosphere, defined in ISO 187, used for the conditioning of test pieces in accordance with [Clause 7](#).

If required, determine the grammage in accordance with ISO 536.

Prepare the apparatus for use in accordance with the manufacturer's instructions and the requirements of this International Standard. Electronic instruments may require a "warm-up" period.

Where alternative measuring pressure ranges are available, select the most suitable range, if necessary by carrying out a preliminary test using the highest available range.

Adjust the clamping system to give a clamping pressure great enough to prevent slippage of the test piece in the clamps but not exceeding 1 200 kPa.

Raise the clamp and insert the test piece in a position enabling the full clamping area to be used, then apply the full clamping pressure to the test piece.

If necessary, zero the hydraulic-pressure-indicating device according to the manufacturer's instructions. Apply hydraulic pressure until the test piece bursts. Retract the piston until the diaphragm is below the level of the diaphragm-clamping plate. Read the indicated bursting pressure to the nearest kilopascal. Release the clamp and prepare the instrument for the next test. Readings shall be rejected when visible slippage of the test piece (as shown by movement of the test piece outside the clamps or by creasing of the test piece in the clamped area) has occurred. In cases of doubt, the use of a larger test piece will frequently establish whether slippage is occurring. Readings shall be rejected if the type of failure (for example, severance at the periphery of the test zone) indicates that the test piece was damaged by excessive clamping pressure or rotation of the clamps during clamping.

If separate results are not required for each surface of the paper in contact with the diaphragm, 20 valid tests shall be carried out to obtain the result. If separate results are required for the two surfaces of paper, a minimum of 10 valid tests shall be carried out on each side.

NOTE 1 The surface in contact with the diaphragm is considered to be the surface under test.

NOTE 2 The main sources of error are as follows:

- incorrect calibration of the pressure-measuring system;
- incorrect rate of increase in pressure (increased rates lead to an apparent increase in bursting strength);

- defective diaphragm, or diaphragm set too high or too low relative to the diaphragm-clamping plate;
- stiff or inelastic diaphragm, giving an apparent increase in bursting strength;
- inadequate or uneven clamping (which generally leads to an apparent increase in bursting strength);
- presence of air in the system (which generally leads to an apparent decrease in bursting strength);
- over-elastic diaphragm (which generally leads to an apparent decrease in bursting strength).

## 9 Expression of results

Calculate the mean bursting strength,  $p$ , in kilopascals, to the nearest kilopascal.

Calculate the standard deviation of the results.

The burst index,  $x$ , expressed in kilopascals square metres per gram, may be calculated from the bursting strength by the formula

$$x = \frac{p}{g}$$

where

$p$  is the mean bursting strength, in kilopascals;

$g$  is the grammage of paper, in grams per square metre, determined in accordance with ISO 536.

Calculate the burst index to three significant figures.

## 10 Test report

The test report shall include the following information:

- a) a reference to this International Standard;
- b) the date and place of testing;
- c) all information necessary for complete identification of the sample;
- d) the make and type of instrument used;
- e) the standard conditioning atmosphere used;
- f) the mean value of the bursting strength, or both mean values if separate results have been obtained for each surface, to the nearest 1 kPa;
- g) if required, the burst index to three significant figures;
- h) the standard deviation of each mean bursting strength reported;
- i) any deviations from the method specified.

## Annex A (normative)

### Dimensions of the clamping system

The dimensions of the clamps are shown in [Figure A.1](#).

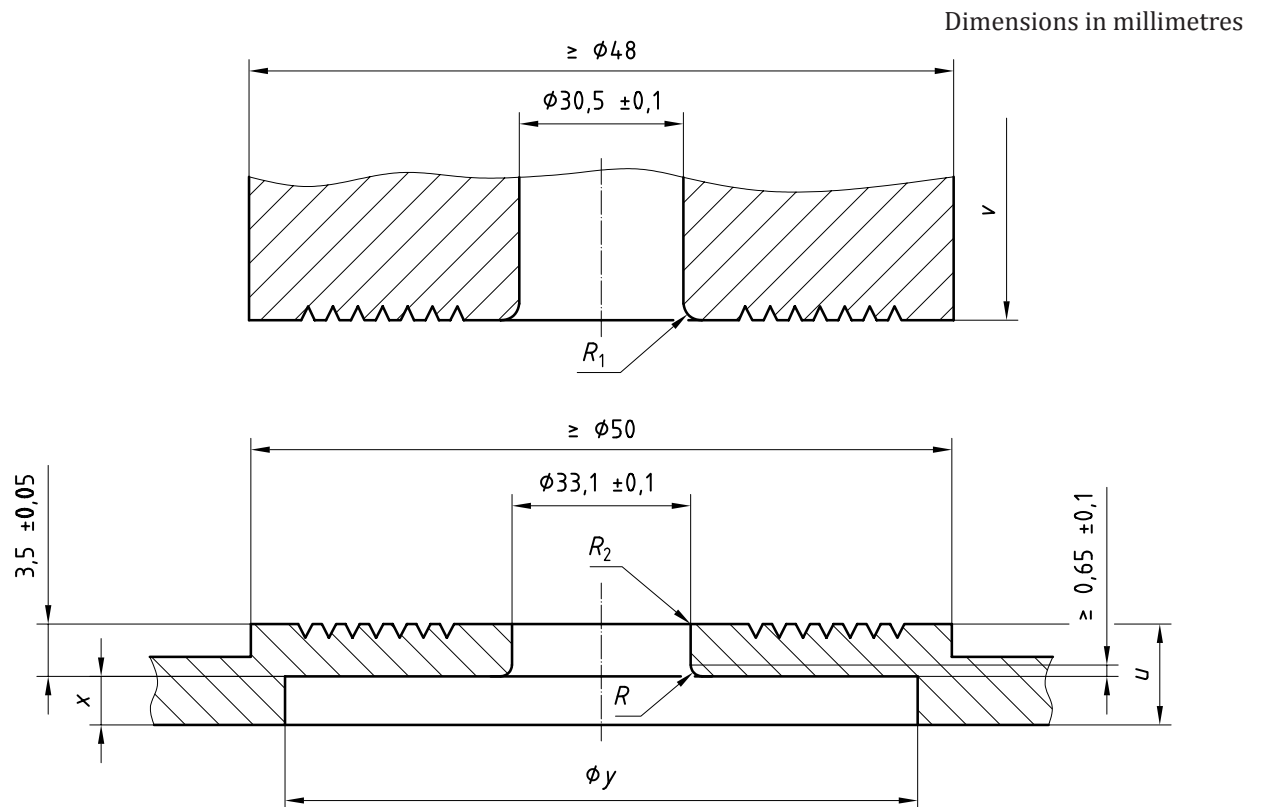

NOTE  $R$ ,  $R_1$ ,  $R_2$ ,  $u$ ,  $v$ ,  $x$  and  $y$  are specified in the text of this annex.

**Figure A.1 — Clamps**

The dimensions of an alternative lower clamp are shown in [Figure A.2](#). This clamp may sometimes be found on instruments of North American manufacture. When this clamp is provided, the radius  $R$ , on the upper clamping plate is about 0,4 mm.

Dimensions  $u$  and  $v$  (see [Figure A.1](#)) are not critical but shall be large enough to ensure that the clamps do not distort during use. For the moving clamp, a minimum thickness of 6,35 mm has been found satisfactory.

Dimensions  $x$  and  $y$  may vary according to the manufacturer of the burst tester and the design of the diaphragm used but are such that the diaphragm is securely clamped.

Radius  $R$  is set by the limits imposed by the dimensions  $3,5 \text{ mm} \pm 0,05 \text{ mm}$  and  $0,65 \text{ mm} \pm 0,1 \text{ mm}$ . The arc shall be tangential to the vertical face of the circular opening and to the horizontal inner surface of the diaphragm clamp. The radius shall be within the range 3 mm to 0,65 mm.

To reduce the danger of damage to the test piece or the diaphragm,  $R_1$  and  $R_2$  shall be very slightly rounded but not sufficiently to affect the bore of the moving clamping plate. (Radii of curvature of about 0,6 mm for  $R_1$  and 0,4 mm for  $R_2$  are recommended.)

To minimize slippage, the clamp surfaces which come into contact with the paper during a test shall have spiral or concentric tool marks on the surface.

The following have been found to be satisfactory:

- a) a continuous spiral 60° V-groove not less than 0,25 mm deep, with a pitch of 0,9 mm ± 0,1 mm, the groove starting at 3,2 mm ± 0,1 mm from the edge of the circular opening;
- b) a series of concentric 60° V-grooves not less than 0,25 mm deep and 0,9 mm ± 0,1 mm apart, the centre of the innermost groove being 3,2 mm ± 0,1 mm from the edge of the circular opening.

The space above the circular opening in the moving clamp shall be of sufficient size to allow free bulging of the test piece and, if enclosed as a design feature, shall be connected to the atmosphere by an orifice of sufficient size to allow air trapped above the test piece to escape. A circular opening of about 4 mm diameter has been found to be suitable.

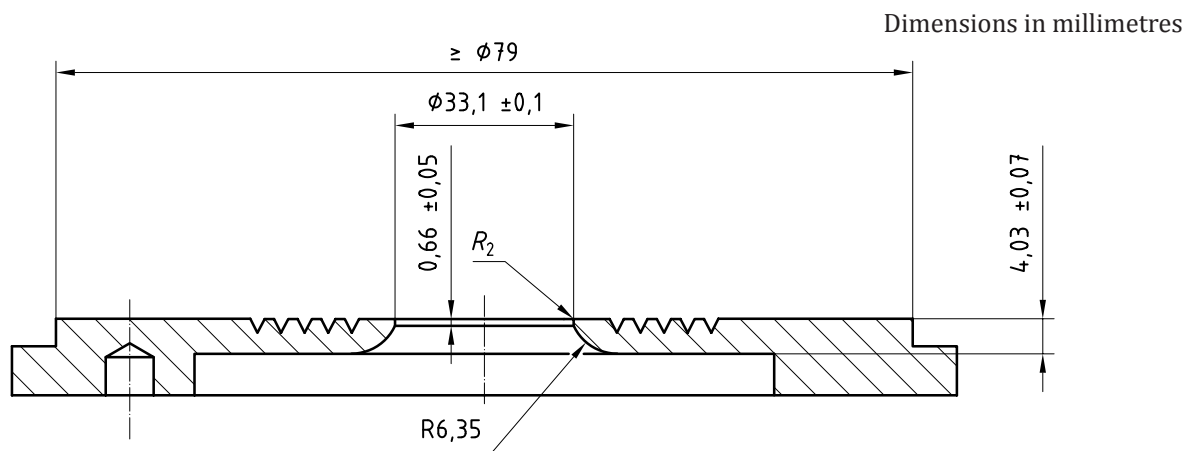

Figure A.2 — Alternative lower clamp

## **Annex B** (normative)

### **Testing the clamps**

Place a piece of pencil carbon paper, together with a piece of thin white paper, between the clamping plates and apply the desired clamping pressure. If the clamping plates are satisfactory, the impression transferred from the carbon paper to the white paper will be clear, uniform and well defined over the whole clamping area. If the moving clamping plate can be rotated, rotate it through 90° and obtain a second impression. The concentricity of the clamping plates may be checked either by checking that the clamping plates line up correctly on a plate fitted with discs on each side corresponding in diameter with the dimensions of the circular opening, or by taking a clamping impression using two sheets of carbon paper with a sheet of thin, white paper between them and checking that the clamping impressions are symmetrical and correspond to within 0,25 mm.

## **Annex C** (normative)

### **Clamping pressure**

Some testers are fitted with a hydraulic or pneumatic clamping device, incorporating a pressure gauge, and can be readily adjusted to give any required clamping pressure. In such cases, it must be stressed that the pressure in the pneumatic or hydraulic system is not necessarily identical with the pressure between the clamps. The areas of the piston and the clamp faces must be taken into account.

In the case of testers fitted with mechanical clamping devices, such as screws or levers, the actual clamping pressure at various settings should be determined by use of a load cell or other suitable device.



## **Annex D** **(normative)**

### **Calibration of pressure-measuring system**

#### **D.1 Static calibration**

The pressure-measuring system may be calibrated statically by means of a deadweight tester of the piston type or by means of a column of mercury. If the pressure-sensing device is sensitive to orientation, calibration should be carried out with the sensor mounted in its normal position in the burst tester. The maximum bursting-pressure-indication system should be calibrated dynamically.

Other methods of static calibration can be used.

#### **D.2 Dynamic calibration**

Dynamic calibration of the complete instrument may be carried out by connecting in parallel an independent maximum-pressure-measuring system. The system shall have a frequency response and accuracy sufficient to measure the maximum pressure during the burst test to better than  $\pm 1,5$  %.

By testing samples covering the working range of the instrument, the error in the indicated peak bursting pressure at various bursting-pressure levels may be determined.

If an error at any point is greater than the requirements of [5.4](#), the source of the error shall be investigated.

## Annex E (informative)

### Precision

#### E.1 General

In 2012, 14 laboratories tested four samples according to ISO 2758. The data have been obtained from CEPI-CTS, the Comparative Testing Service of the Confederation of European Paper Industries.

The data are presented in [Tables E.1](#) and [E.2](#).

The calculations were made according to ISO/TR 24498[3] and TAPPI T 1200[5].

The repeatability standard deviation reported is the “pooled” repeatability standard deviation that is, the standard deviation is calculated as the root-mean-square of the standard deviations of the participating laboratories. This differs from the conventional definition of repeatability in ISO 5725-1.[2]

The repeatability and reproducibility limits reported are estimates of the maximum difference which should be expected in 19 of 20 instances, when comparing two test results for material similar to those described under similar test conditions. These estimates may not be valid for different materials or different test conditions. Repeatability and reproducibility limits are calculated by multiplying the repeatability and reproducibility standard deviations by 2,77.

NOTE 1 The repeatability standard deviation and the within-laboratory standard deviation are identical. However, the reproducibility standard deviation is NOT the same as the between-laboratories standard deviation. The reproducibility standard deviation includes both the between-laboratories standard deviation and the standard deviation within a laboratory, viz.:

$$s_{\text{repeatability}}^2 = s_{\text{within lab}}^2 \quad \text{but} \quad s_{\text{reproducibility}}^2 = s_{\text{within lab}}^2 + s_{\text{between lab}}^2$$

NOTE 2  $2,77 = 1,96\sqrt{2}$ , provided that the test results have a normal distribution and that the standard deviation  $s$  is based on a large number of tests.

**Table E.1 — Estimation of the repeatability**

Sample	Number of laboratories	Mean bursting strength kPa	Repeatability standard deviation $s_r$ kPa	Coefficient of variation $C_{V,r}$ %	Repeatability limit $r$ kPa
Sample 1	14	137	10,3	7,5	28,6
Sample 2	13	323	14,4	4,5	39,9
Sample 3	14	645	19,6	3,0	54,3
Sample 4	13	825	26,1	3,2	72,3

**Table E.2 — Estimation of the reproducibility**

<b>Sample</b>	<b>Number of laboratories</b>	<b>Mean bursting strength</b> kPa	<b>Reproducibility standard deviation</b> $s_R$ kPa	<b>Coefficient of variation</b> $C_{V,R}$ %	<b>Reproducibility limit</b> $R$ kPa
Sample 1	14	137	13,5	9,8	37,4
Sample 2	13	323	21,5	6,7	60,0
Sample 3	14	645	40,0	6,2	111,0
Sample 4	13	825	59,4	7,2	164,8

## Bibliography

- [1] ISO 2759:2001, *Board — Determination of bursting strength*
- [2] ISO 5725-1, *Accuracy (trueness and precision) of measurement methods and results — Part 1: General principles and definitions*
- [3] ISO/TR 24498, *Paper, board and pulps — Estimation of uncertainty for test methods*
- [4] AS/NZS 1301-403s:1997, *Methods of test for pulp and paper — Bursting strength of paper. Appita standard*<sup>1)</sup>
- [5] TAPPI T 1200, *Interlaboratory evaluation of test methods to determine TAPPI repeatability and reproducibility*
- [6] BRAUNS O., DANIELSSON E., JORDANSSON L. *Svensk Papperstidning* 23 867 (1954)<sup>1)</sup>
- [7] TUCK N.G.M., MASON S.G., FAICHNEY L.M. *Pulp and Paper Mag. Canada* 54 5 102 ( 1953)<sup>1)</sup>

---

1) Methods of dynamic calibration for pressure gauges are described in this publication.







# British Standards Institution (BSI)

BSI is the national body responsible for preparing British Standards and other standards-related publications, information and services.

BSI is incorporated by Royal Charter. British Standards and other standardization products are published by BSI Standards Limited.

## About us

We bring together business, industry, government, consumers, innovators and others to shape their combined experience and expertise into standards-based solutions.

The knowledge embodied in our standards has been carefully assembled in a dependable format and refined through our open consultation process. Organizations of all sizes and across all sectors choose standards to help them achieve their goals.

## Information on standards

We can provide you with the knowledge that your organization needs to succeed. Find out more about British Standards by visiting our website at [bsigroup.com/standards](http://bsigroup.com/standards) or contacting our Customer Services team or Knowledge Centre.

## Buying standards

You can buy and download PDF versions of BSI publications, including British and adopted European and international standards, through our website at [bsigroup.com/shop](http://bsigroup.com/shop), where hard copies can also be purchased.

If you need international and foreign standards from other Standards Development Organizations, hard copies can be ordered from our Customer Services team.

## Subscriptions

Our range of subscription services are designed to make using standards easier for you. For further information on our subscription products go to [bsigroup.com/subscriptions](http://bsigroup.com/subscriptions).

With **British Standards Online (BSOL)** you'll have instant access to over 55,000 British and adopted European and international standards from your desktop. It's available 24/7 and is refreshed daily so you'll always be up to date.

You can keep in touch with standards developments and receive substantial discounts on the purchase price of standards, both in single copy and subscription format, by becoming a **BSI Subscribing Member**.

**PLUS** is an updating service exclusive to BSI Subscribing Members. You will automatically receive the latest hard copy of your standards when they're revised or replaced.

To find out more about becoming a BSI Subscribing Member and the benefits of membership, please visit [bsigroup.com/shop](http://bsigroup.com/shop).

With a **Multi-User Network Licence (MUNL)** you are able to host standards publications on your intranet. Licences can cover as few or as many users as you wish. With updates supplied as soon as they're available, you can be sure your documentation is current. For further information, email [bsmusales@bsigroup.com](mailto:bsmusales@bsigroup.com).

## BSI Group Headquarters

389 Chiswick High Road London W4 4AL UK

## Revisions

Our British Standards and other publications are updated by amendment or revision.

We continually improve the quality of our products and services to benefit your business. If you find an inaccuracy or ambiguity within a British Standard or other BSI publication please inform the Knowledge Centre.

## Copyright

All the data, software and documentation set out in all British Standards and other BSI publications are the property of and copyrighted by BSI, or some person or entity that owns copyright in the information used (such as the international standardization bodies) and has formally licensed such information to BSI for commercial publication and use. Except as permitted under the Copyright, Designs and Patents Act 1988 no extract may be reproduced, stored in a retrieval system or transmitted in any form or by any means – electronic, photocopying, recording or otherwise – without prior written permission from BSI. Details and advice can be obtained from the Copyright & Licensing Department.

## Useful Contacts:

### Customer Services

**Tel:** +44 845 086 9001

**Email (orders):** [orders@bsigroup.com](mailto:orders@bsigroup.com)

**Email (enquiries):** [cservices@bsigroup.com](mailto:cservices@bsigroup.com)

### Subscriptions

**Tel:** +44 845 086 9001

**Email:** [subscriptions@bsigroup.com](mailto:subscriptions@bsigroup.com)

### Knowledge Centre

**Tel:** +44 20 8996 7004

**Email:** [knowledgecentre@bsigroup.com](mailto:knowledgecentre@bsigroup.com)

### Copyright & Licensing

**Tel:** +44 20 8996 7070

**Email:** [copyright@bsigroup.com](mailto:copyright@bsigroup.com)



...making excellence a habit.™