

BS EN ISO 2739:2012



BSI Standards Publication

# Sintered metal bushings — Determination of radial crushing strength (ISO 2739:2012)

**bsi.**

...making excellence a habit.™

**National foreword**

This British Standard is the UK implementation of EN ISO 2739:2012. It supersedes BS EN ISO 2739:2010 which is withdrawn.

The UK participation in its preparation was entrusted to Technical Committee ISE/65, Sintered metal components.

A list of organizations represented on this committee can be obtained on request to its secretary.

This publication does not purport to include all the necessary provisions of a contract. Users are responsible for its correct application.

© The British Standards Institution 2012. Published by BSI Standards Limited 2012

ISBN 978 0 580 71799 4

ICS 21.060.60; 77.040.10; 77.160

**Compliance with a British Standard cannot confer immunity from legal obligations.**

This British Standard was published under the authority of the Standards Policy and Strategy Committee on 31 July 2012.

**Amendments issued since publication**

Date	Text affected
------	---------------

---

EUROPEAN STANDARD

**EN ISO 2739**

NORME EUROPÉENNE

EUROPÄISCHE NORM

July 2012

ICS 77.160; 77.040.10

Supersedes EN ISO 2739:2010

English Version

## Sintered metal bushings - Determination of radial crushing strength (ISO 2739:2012)

Bagues en métal fritté - Détermination de la résistance à l'écrasement radial (ISO 2739:2012)

Buchsen aus Sintermetall - Bestimmung der radialen Bruchfestigkeit (ISO 2739:2012)

This European Standard was approved by CEN on 16 June 2012.

CEN members are bound to comply with the CEN/CENELEC Internal Regulations which stipulate the conditions for giving this European Standard the status of a national standard without any alteration. Up-to-date lists and bibliographical references concerning such national standards may be obtained on application to the CEN-CENELEC Management Centre or to any CEN member.

This European Standard exists in three official versions (English, French, German). A version in any other language made by translation under the responsibility of a CEN member into its own language and notified to the CEN-CENELEC Management Centre has the same status as the official versions.

CEN members are the national standards bodies of Austria, Belgium, Bulgaria, Croatia, Cyprus, Czech Republic, Denmark, Estonia, Finland, Former Yugoslav Republic of Macedonia, France, Germany, Greece, Hungary, Iceland, Ireland, Italy, Latvia, Lithuania, Luxembourg, Malta, Netherlands, Norway, Poland, Portugal, Romania, Slovakia, Slovenia, Spain, Sweden, Switzerland, Turkey and United Kingdom.



EUROPEAN COMMITTEE FOR STANDARDIZATION  
COMITÉ EUROPÉEN DE NORMALISATION  
EUROPÄISCHES KOMITEE FÜR NORMUNG

**Management Centre: Avenue Marnix 17, B-1000 Brussels**

## Foreword

This document (EN ISO 2739:2012) has been prepared by Technical Committee ISO/TC 119 "Powder metallurgy".

This European Standard shall be given the status of a national standard, either by publication of an identical text or by endorsement, at the latest by January 2013, and conflicting national standards shall be withdrawn at the latest by January 2013.

Attention is drawn to the possibility that some of the elements of this document may be the subject of patent rights. CEN [and/or CENELEC] shall not be held responsible for identifying any or all such patent rights.

This document supersedes EN ISO 2739:2010.

According to the CEN/CENELEC Internal Regulations, the national standards organizations of the following countries are bound to implement this European Standard: Austria, Belgium, Bulgaria, Croatia, Cyprus, Czech Republic, Denmark, Estonia, Finland, Former Yugoslav Republic of Macedonia, France, Germany, Greece, Hungary, Iceland, Ireland, Italy, Latvia, Lithuania, Luxembourg, Malta, Netherlands, Norway, Poland, Portugal, Romania, Slovakia, Slovenia, Spain, Sweden, Switzerland, the United Kingdom and Turkey.

### Endorsement notice

The text of ISO 2739:2012 has been approved by CEN as a EN ISO 2739:2012 without any modification.

## Foreword

ISO (the International Organization for Standardization) is a worldwide federation of national standards bodies (ISO member bodies). The work of preparing International Standards is normally carried out through ISO technical committees. Each member body interested in a subject for which a technical committee has been established has the right to be represented on that committee. International organizations, governmental and non-governmental, in liaison with ISO, also take part in the work. ISO collaborates closely with the International Electrotechnical Commission (IEC) on all matters of electrotechnical standardization.

International Standards are drafted in accordance with the rules given in the ISO/IEC Directives, Part 2.

The main task of technical committees is to prepare International Standards. Draft International Standards adopted by the technical committees are circulated to the member bodies for voting. Publication as an International Standard requires approval by at least 75 % of the member bodies casting a vote.

Attention is drawn to the possibility that some of the elements of this document may be the subject of patent rights. ISO shall not be held responsible for identifying any or all such patent rights.

ISO 2739 was prepared by Technical Committee ISO/TC 119, *Powder metallurgy*, Subcommittee SC 3, *Sampling and testing methods for sintered metal materials (excluding hardmetals)*.

This third edition cancels and replaces the second edition (ISO 2739:2006), which has been technically revised.



# Sintered metal bushings — Determination of radial crushing strength

## 1 Scope

This International Standard specifies a method of measuring the radial crushing strength of sintered metal parts in the form of hollow cylinders, commonly known as bushings.

This method is applicable to sintered bushings composed of pure or alloyed metal powders.

## 2 Principle

A hollow cylinder is submitted to a continuously increasing radial load until breakage occurs, provided that the deformation does not exceed 10 % of the diameter. The maximum load observed is used to calculate a value in relation to the dimensions of the hollow cylinder known as “radial crushing strength”.

## 3 Apparatus

**3.1 Pressing apparatus**, that enables a radial load to be applied to a hollow cylinder.

**3.2 Load-measuring device**, accurate and readable to 0,1 % of the full scale. The lowest testing range that can provide a measureable result should be used.

**3.3 Loading plates**, two flat, ground, hardened steel plates of sufficient size to encompass the test specimen that can be fastened to the press platens and that will remain parallel.

## 4 Test piece

The test piece (see Figure 1) shall be in the form of a sintered hollow cylinder (which may or may not be oil-impregnated), without flanges, notches, grooves, pronounced chamfers, drilled holes, oilways or keyways. If necessary, the cylinder may be machined but, in this case, the results obtained may differ from those obtained with a cylinder that has not been machined.

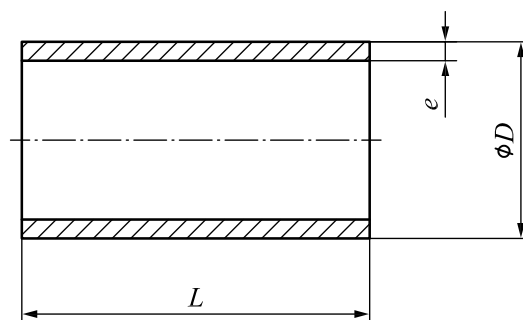

### Key

- $L$  length of the hollow cylinder
- $D$  external diameter of the hollow cylinder
- $e$  thickness of the cylinder wall

Figure 1 — Test piece

## 5 Procedure

**5.1** Clean any surface oil from the specimen and measure the outside diameter, the inside diameter and the length within 0,5 % tolerance.

For test specimens with an outside diameter  $< 10$  mm, the outside diameter may be measured to the nearest 0,05 mm.

For test specimens with an inside diameter  $< 10$  mm, the inside diameter may also be measured to the nearest 0,05 mm.

For test specimens with a length ranging from  $\geq 2$  mm to  $< 10$  mm, the length may be measured to the nearest 0,05 mm.

For test specimens with a length  $< 2$  mm, the length may be measured to the nearest 0,01 mm.

**5.2** Wipe the loading plates clean and lay the test specimen in the central region of the lower plate, the axis of the test specimen being parallel to the planes of the plates (see Figure 2).

**5.3** Bring the upper plate and the test specimen into contact and slowly apply the diametric load at a rate (platen speed) that does not exceed 5 mm/min.

**5.4** Record the load at which the test specimen fractures or the first reading at which the applied load drops. The measuring value of the load should be kept at 0,1 % of the total load.

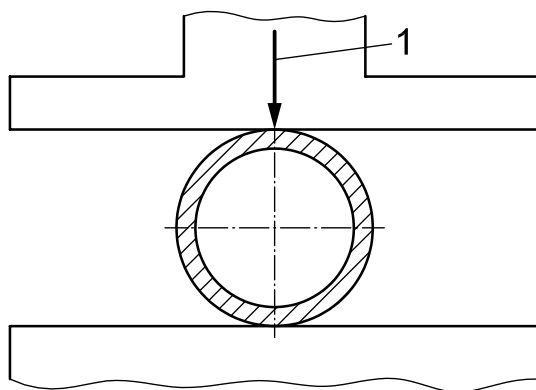

**Key**

1 applied load

**Figure 2 — Test arrangement**



## 6 Expression of results

The radial crushing strength of the bushing,  $K$ , in newtons per square millimetre, is given by the following equation:

$$K = \frac{F(D - e)}{Le^2}$$

where

- $F$  is the maximum load, in newtons (N), incurring fracture;
- $L$  is the length, in millimetres (mm), of the hollow cylinder;
- $D$  is the external diameter, in millimetres (mm), of the hollow cylinder;
- $e$  is the thickness, in millimetres (mm), of the cylinder wall.

This equation is valid only if the ratio  $e/D$  is less than  $1/3^1$ .

## 7 Precision statement (Statement of accuracy)

On the basis of test error alone, the difference in the absolute value of two test results obtained in the same laboratory will be expected to exceed repeatability ( $r$ ) only 5 % of the time. If such a difference is found to be larger than  $r$ , there is reason to question one or both results.

Similarly, the difference between two test results obtained in different laboratories will be expected to exceed reproducibility ( $R$ ) only 5 % of the time. If the difference is found to be larger than  $R$ , there is reason to question one or both measurements.

**Table 1 — Precision data**

Values in megapascals

Material	$K$	$r$	$R$
CTG — 1001 — K23 (C-T10G-K160)	214	15	23
FC — 1000 — K 20	400	34	45
FC — 0208 — 50 (F-08C2-340)	785	48	48
1 MPa = 1 N/mm <sup>2</sup>			

NOTE With permission, this clause was taken from MPIF<sup>2)</sup> Standard 55, 1998, *Determination of radial crush strength ( $K$ ) of powder metallurgy test specimens*.

## 8 Test report

The test report shall include the following information:

- a) a reference to this International Standard;
- b) all details necessary for identification of the specimen;
- c) whether the specimen is as sintered or sized;
- d) whether the specimen has been machined or not, and, if so, a drawing showing how the specimen has been taken from the part;

- 1) In this case, the tensile strength is approximately equal to  $0,5K$ .
- 2) Metal Powder Industries Federation, USA

- e) whether the specimen has been oil-impregnated or not;
- f) the result obtained, reported to the nearest 10 MPa;
- g) all operations not specified in this International Standard, or regarded as optional;
- h) details of any occurrence that may have affected the result.

If necessary, the data required for the identification of the test piece shall be agreed between the manufacturer and the user.







# British Standards Institution (BSI)

BSI is the national body responsible for preparing British Standards and other standards-related publications, information and services.

BSI is incorporated by Royal Charter. British Standards and other standardization products are published by BSI Standards Limited.

## About us

We bring together business, industry, government, consumers, innovators and others to shape their combined experience and expertise into standards-based solutions.

The knowledge embodied in our standards has been carefully assembled in a dependable format and refined through our open consultation process. Organizations of all sizes and across all sectors choose standards to help them achieve their goals.

## Information on standards

We can provide you with the knowledge that your organization needs to succeed. Find out more about British Standards by visiting our website at [bsigroup.com/standards](http://bsigroup.com/standards) or contacting our Customer Services team or Knowledge Centre.

## Buying standards

You can buy and download PDF versions of BSI publications, including British and adopted European and international standards, through our website at [bsigroup.com/shop](http://bsigroup.com/shop), where hard copies can also be purchased.

If you need international and foreign standards from other Standards Development Organizations, hard copies can be ordered from our Customer Services team.

## Subscriptions

Our range of subscription services are designed to make using standards easier for you. For further information on our subscription products go to [bsigroup.com/subscriptions](http://bsigroup.com/subscriptions).

With **British Standards Online (BSOL)** you'll have instant access to over 55,000 British and adopted European and international standards from your desktop. It's available 24/7 and is refreshed daily so you'll always be up to date.

You can keep in touch with standards developments and receive substantial discounts on the purchase price of standards, both in single copy and subscription format, by becoming a **BSI Subscribing Member**.

**PLUS** is an updating service exclusive to BSI Subscribing Members. You will automatically receive the latest hard copy of your standards when they're revised or replaced.

To find out more about becoming a BSI Subscribing Member and the benefits of membership, please visit [bsigroup.com/shop](http://bsigroup.com/shop).

With a **Multi-User Network Licence (MUNL)** you are able to host standards publications on your intranet. Licences can cover as few or as many users as you wish. With updates supplied as soon as they're available, you can be sure your documentation is current. For further information, email [bsmusales@bsigroup.com](mailto:bsmusales@bsigroup.com).

## BSI Group Headquarters

389 Chiswick High Road London W4 4AL UK

## Revisions

Our British Standards and other publications are updated by amendment or revision.

We continually improve the quality of our products and services to benefit your business. If you find an inaccuracy or ambiguity within a British Standard or other BSI publication please inform the Knowledge Centre.

## Copyright

All the data, software and documentation set out in all British Standards and other BSI publications are the property of and copyrighted by BSI, or some person or entity that owns copyright in the information used (such as the international standardization bodies) and has formally licensed such information to BSI for commercial publication and use. Except as permitted under the Copyright, Designs and Patents Act 1988 no extract may be reproduced, stored in a retrieval system or transmitted in any form or by any means – electronic, photocopying, recording or otherwise – without prior written permission from BSI. Details and advice can be obtained from the Copyright & Licensing Department.

## Useful Contacts:

### Customer Services

**Tel:** +44 845 086 9001

**Email (orders):** [orders@bsigroup.com](mailto:orders@bsigroup.com)

**Email (enquiries):** [cservices@bsigroup.com](mailto:cservices@bsigroup.com)

### Subscriptions

**Tel:** +44 845 086 9001

**Email:** [subscriptions@bsigroup.com](mailto:subscriptions@bsigroup.com)

### Knowledge Centre

**Tel:** +44 20 8996 7004

**Email:** [knowledgecentre@bsigroup.com](mailto:knowledgecentre@bsigroup.com)

### Copyright & Licensing

**Tel:** +44 20 8996 7070

**Email:** [copyright@bsigroup.com](mailto:copyright@bsigroup.com)



...making excellence a habit.™