

# Plastics —

## **Determination of the gas transmission rate of films and thin sheets under atmospheric pressure — Manometric method**

The European Standard EN ISO 2556:2000 has the status of a  
British Standard

ICS 83.140.10

# Committees responsible for this British Standard

This British Standard, having been prepared under the direction of the Plastics Standards Committee, was published under the authority of the Executive Board and comes into effect on 31 August 1979

© BSI 31 October 2001

## Amendments issued since publication

Amd. No.	Date of issue	Comments
13432	31 October 2001	Implementation of the European Standard

The following BSI references relate to the work on this standard:  
Committee reference PLC/17  
Draft for comment 78/55155 DC

ISBN 0 580 10905 4

# Contents

	Page
Committees responsible	Inside front cover
National foreword	ii
<hr/>	
1 Scope and field of application	1
2 Reference	1
3 Definition	1
4 Principle	1
5 Apparatus and materials	1
6 Test specimens	3
7 Procedure	3
8 Expression of results	4
9 Test report	6
<hr/>	
Figure 1 — Example of apparatus with overflowing [5.4, 1)a)]	7
Figure 2 — Example of apparatus without overflowing [5.4, 2)]	8
<hr/>	

## National foreword

This British Standard is the official English language version of EN ISO 2556:2000.

The UK participation in its preparation was entrusted to Technical Committee PRI/21, Testing of plastics, which has the responsibility to:

- aid enquirers to understand the text;
- present to the responsible international/European committee any enquiries on the interpretation, or proposals for change, and keep the UK interests informed;
- monitor related international and European developments and promulgate them in the UK.

A list of organizations represented on this committee can be obtained on request to its secretary.

### Cross-references

The British Standards which implement international or European publications referred to in this document may be found in the BSI Standards Catalogue under the section entitled “International Standards Correspondence Index”, or by using the “Find” facility of the BSI Standards Electronic Catalogue.

A British Standard does not purport to include all the necessary provisions of a contract. Users of British Standards are responsible for their correct application.

**Compliance with a British Standard does not of itself confer immunity from legal obligations.**

### Summary of pages

This document comprises a front cover, an inside front cover, pages i and ii, the EN ISO title page, the EN ISO foreword page, pages 1 to 8, an inside back cover and a back cover.

The BSI copyright notice displayed in this document indicates when the document was last issued.

ICS 83.140

English version

Plastics — Determination of the gas transmission rate of  
films and thin sheets under atmospheric pressure —  
Manometric method

(ISO 2556:1974)

Matières plastiques — Détermination du coefficient  
de transmission d'un gaz par les feuilles et plaques  
minces, sous pression atmosphérique —  
Méthode manométrique  
(ISO 2556:1974)

Kunststoffe — Bestimmung der Gasdurchlässigkeit  
von Folien und dünnen Tafeln unter  
atmosphärischem Druck —  
Druckmessgerät-Verfahren  
(ISO 2556:1974)

This European Standard was approved by CEN on 8 September 2000.

CEN members are bound to comply with the CEN/CENELEC Internal Regulations which stipulate the conditions for giving this European Standard the status of a national standard without any alteration. Up-to-date lists and bibliographical references concerning such national standards may be obtained on application to the Central Secretariat or to any CEN member.

This European Standard exists in three official versions (English, French, German). A version in any other language made by translation under the responsibility of a CEN member into its own language and notified to the Central Secretariat has the same status as the official versions.

CEN members are the national standards bodies of Austria, Belgium, Czech Republic, Denmark, Finland, France, Germany, Greece, Iceland, Ireland, Italy, Luxembourg, Netherlands, Norway, Portugal, Spain, Sweden, Switzerland and United Kingdom.

**CEN**

European Committee for Standardization  
Comité Européene de Normalisation  
Europäisches Komitee für Normung

**Central Secretariat: rue de Stassart, 36 B-1050 Brussels**

## Foreword

The text of the International Standard from Technical Committee ISO/TC 61, Plastics, of the International Organization for Standardization (ISO) has been taken over as a European Standard by Technical Committee CEN/TC 249, Plastics, the Secretariat of which is held by IBN.

This European Standard shall be given the status of a national standard, either by publication of an identical text or by endorsement, at the latest by March 2001, and conflicting national standards shall be withdrawn at the latest by March 2001.

According to the CEN/CENELEC Internal Regulations, the national standards organizations of the following countries are bound to implement this European Standard: Austria, Belgium, Czech Republic, Denmark, Finland, France, Germany, Greece, Iceland, Ireland, Italy, Luxembourg, Netherlands, Norway, Portugal, Spain, Switzerland and the United Kingdom.

## 1 Scope and field of application

This International Standard specifies a method for the determination of the gas transmission rate of plastics films and thin sheets.

The limits of the values which can be measured are from 1 to 20 000 cm<sup>3</sup>/m<sup>2</sup>.d.atm.

The method can be used for measurements made either with air or with other test gases.

## 2 Reference

ISO/R 291, *Plastics — Standard atmospheres for conditioning and testing*.

## 3 Definition

### 3.1

#### gas transmission rate

the volume of gas which, under steady conditions, crosses unit area of the sample in unit time under unit pressure difference and at constant temperature. This volume is expressed at standard temperature and pressure

the rate depends on the thickness of the test specimen, and the reliability of the results depends on the evenness of the specimen thickness

the rate is usually expressed in cubic centimetres (at 0 °C under standard atmospheric pressure per square metre per 24 h under a pressure difference of 1 atm (cm<sup>3</sup>/m<sup>2</sup>.d.atm)

NOTE 1 The SI unit of gas transmission rate is fm/Pa.s:

[1 fm (femtometre) = 10<sup>-15</sup> m];

1 cm<sup>3</sup>/m<sup>2</sup>.d.atm = 0,114 3 fm/Pa.s and;

1 fm/Pa.s = 8,752 cm<sup>3</sup>/m<sup>2</sup>.d.atm.

NOTE 2 The standard atmospheric pressure corresponds to the pressure of a mercury column 760 mm high: either 1 013 mbar or 101,3 kPa.

## 4 Principle

The plastic test specimen separates two chambers numbered 1 and 2. Chamber 1 contains the test gas at atmospheric pressure. Chamber 2, of known initial volume, has the air pumped out until the pressure is practically zero, then is hermetically sealed.

The quantity of gas which passes through the specimen from chamber 1 to chamber 2 is determined as a function of time by measuring the increases of pressure occurring in chamber 2 by means of a manometer.

The transmission rate is calculated from the values obtained, excluding the initial period during which the rate of passage of gas increases with time.

## 5 Apparatus and materials

The apparatus which comprises the parts described in 5.1, 5.2, 5.3 and 5.4, and of which suitable examples are shown in Figure 1 and Figure 2, must be placed in an enclosure with the temperature constant to within ±2 °C during the test.

5.1 *Metal cell* consisting of two detachable parts, as follows:

- 1) an upper part forming the cylindrical chamber 1 to contain the test gas, provided with tubes for the entry and exit of the gas employed;
  - 2) a lower part forming a plane and polished "test plate" of diameter 100 to 120 mm and having at its centre either:
    - a) a cavity of about 20 mm diameter containing a perforated disc and below this a small empty space so that the total depth of the cavity is 12 to 15 mm (see Figure 1). In this type of apparatus a filter paper must be interposed between the specimen and the test plate. The diameter of this filter paper must be near, but not greater than, the internal diameter of the gasket;
- or,
- b) a cavity about 60 mm diameter and a few millimetres deep, filled with a sintered disc of glass or of bronze (see Figure 2).

The filter paper indicated in a) or the sintered disc indicated in b) are to support the test specimen while at the same time allowing the passage of gas.

In case b) the upper part of the sintered disc must be level with the test plate so that the specimen rests flat over its whole surface.

The closed space below the test specimen forms chamber 2, and is attached to a capillary tube (5.2) forming the manometer and to a vacuum pump (5.5).

The two parts of the cell are clamped together by means of an effective clamping device, a circular gasket of rubber being used to isolate the cell completely from the external atmosphere and to prevent the passage of gas from chamber 1 to chamber 2 other than through the test specimen.

**NOTE** It is recommended that a check of the airtightness of the apparatus should be made by carrying out a blank test in accordance with the procedure of clause 7 but with the test specimen replaced by metal foil.

The level of the mercury in the capillary must remain practically unchanged during a period of the same order as that needed for the proposed measurements.

**5.2 Calibrated capillary tube** about 1,5 to 2 mm internal diameter and 200 to 400 mm in length, connected to the base of the metal cell. A scale graduated to 0,5 mm indicates the mercury level in the capillary tube.

**5.3 U-tube** about 5 mm diameter, connected to the bottom of the capillary tube as shown in Figure 1 and Figure 2.

One arm of the tube is closed. The other arm is joined to a vacuum stopcock (which can be connected to a vacuum pump) and to a mercury reservoir (5.4) into which the mercury can be poured by overflowing.

**5.4 Mercury reservoir** fixed to the arm of the U-tube connected to the vacuum stopcock. This fixing can be done by method 1) or 2) described below.

- 1) Fixing directly to the U-tube arm (see Figure 1).

This type of apparatus can be arranged to function either with or without overflowing of mercury during the test.

- a) In the case of apparatus with overflowing, the U-tube is filled with mercury up to the overflowing level which also corresponds to the scale zero (as shown in Figure 1).

During the test the mercury level is maintained constant by overflowing. Nevertheless the regulation of the level is not altogether perfect since the overflowing occurs jerkily.

It may therefore be preferable to use the apparatus in the manner described in b).

- b) In the case of apparatus without overflowing, the U-tube is only filled to a point appreciably below the overflowing level, so that the whole test is carried out without overflowing. In this case the scale zero is below the overflowing level and in the calculation a correction is essential (see 8.2).

- 2) The reservoir may be fixed to a greatly enlarged portion of this arm of the tube (about 20 mm diameter) and there is no overflowing during the test (see Figure 2).

**5.5 Vacuum pump** giving a pressure at the most equal to 13 Pa (0,13 mbar or 0,1 mmHg) in the lower chamber, and a gauge to measure this pressure with an accuracy of 6 Pa (0,06 bar or 0,05 mmHg) or better.

**5.6 Mercury barometer.**

**5.7 Thermometer** which can be read to 0,5 °C.

**5.8 Mercury.**

**5.9 Test gases and drying column** if required.



## 6 Test specimens

The specimens shall be representative of the batch of sheet or film for test and free from marks or visible defects (creases, thin spots, porosity, holes, etc.).

They shall be in the form of discs with a diameter, depending on the apparatus used, large enough to overlap the joint between the two portions of the metal cell. This diameter is usually about 80 mm.

At least three specimens must be tested.

Specimens of hygroscopic materials shall be conditioned in the selected atmosphere, preferably one of the atmospheres defined in ISO/R 291.

The duration of conditioning depends on the material and shall be specified.

## 7 Procedure

Carry out the test within the enclosure specified in clause 5 controlled at  $23 \pm 2$  °C, or if required at one of the other temperatures given in ISO/R 291.

**7.1** Introduce the mercury into the reservoir (5.4). The quantity shall be such that, after pouring out the mercury into the capillary tube and the two arms of the U-tube, the level of the mercury is at the zero graduation of the capillary (and a portion overflows back into the reservoir when an apparatus used with overflowing [5.4, 1)a]) is employed).

**7.2** If an apparatus according to 5.1, 2)a) is used, place a circle of filter paper of sufficient size on the test plate.

**7.3** Smear a very thin film of vacuum grease in the region of the joint, taking care not to put it on the filter paper.

**7.4** Mount the specimen, then the rubber gasket, and finally the upper part of the metal cell.

**7.5** Clamp the two parts of the cell together so that the joint is perfectly airtight.

**7.6** Join the gas entry tube through the drying column to the reservoir of compressed gas. Pass the gas slowly into chamber 1 throughout the test.

NOTE By agreement, the drying column may be omitted and gas with a known percentage humidity employed. This point must then be included in the test report.

**7.7** Connect the stopcock to the vacuum pump and operate the pump until the pressure in chamber 2 is less than 27 Pa (0,2 mmHg), checked with the gauge described in 5.5.

**7.8** Close the stopcock, then tilt the apparatus to cause the mercury to run into the capillary and the arms of the U-tube.

Fix the apparatus upright so that the capillary tube is vertical.

Check that the mercury level in the capillary is at the zero of the scale. If not, adjust the quantity of mercury by tilting the apparatus.

If the apparatus is used with overflowing of mercury [5.4, 1)a)], a part of the mercury must be returned to the reservoir.

In all cases the mercury must be at the same level in the three tubes (zero level of the scale).

**7.9** Note the value  $h$  of the mercury level in the capillary as a function of time  $t$ , remembering that this value  $h$  is measured from the mercury level at the start of the test.

NOTE During the test, the difference between the mercury levels in the two arms of the U-tube must always be small. If the mercury level in the closed arm is observed to rise above the level in the other arm, this indicates that there is a leak at the stopcock.

Continue the test until the variation of  $h$  for equal intervals of time remains constant or decreases very gradually during five or six successive intervals of time.

The accuracy of the readings of  $h$  and  $t$  and the spacing of the time intervals depends on the apparatus and on the transmission rate to be measured. The accuracy of reading must be such that the results of measurements of difference in  $h$  and difference in  $t$  finally used in the calculation (see 8.3) are accurate to 1 to 2 % or better

NOTE The measurements of mercury level must be made at least to the nearest 0,25 mm. However, it is recommended that, for transmission rates below 100 cm<sup>3</sup>/m<sup>2</sup>.d.atm, these measurements be made to the nearest 0,1 mm; a good magnifying glass or a cathetometer is therefore necessary.

The measurements of time must be made to the nearest minute if the rates are less than 100 cm<sup>3</sup>/m<sup>2</sup>.d.atm, and to the nearest 5 s if the rates are greater.

**7.10** At the end of the measurements, return the mercury to the reservoir, allow air to enter the apparatus, turn off the gas supply, take out the test specimen and clean the test plate.

**7.11** At the end of the test, measure and record the atmospheric pressure  $H$  in centimetres of mercury, by means of the barometer (5.6).

NOTE If the sample has a very low transmission rate and if the apparatus allows, it is recommended that the volume of chamber 2 be reduced by a metallic packing block placed in the empty cavity. This block, which has the effect of increasing the rate of displacement of the mercury in the capillary, must nevertheless allow sufficient duration of measurement to reach the constant regime before the end of the test.

## 8 Expression of results

### 8.1 Initial volume of chamber 2

This value ( $V$ ), is a constant for a given apparatus. It is the volume, in cubic centimetres, of chamber 2 from the lower face of the test specimen when it is pressed onto the support to the zero graduation of the capillary; it is reduced by the volume of the packing block when used.

This volume comprises:

- a) The volume of the voids in the filter paper and the perforated disc, or in the sintered disc of glass or bronze.

The calculation of this volume can be made by determining the total volume and subtracting from it the volume of the solid calculated from the mass and density of the porous product (density of cellulose fibre = 1,45 g/cm<sup>3</sup>).

- b) The volume of the empty space in the lower plate (if present), less the volume of any packing block used.
- c) The volume of the capillary as far as the zero graduation.

### 8.2 Calculation of correction coefficient

If the test has been made with overflowing [5.4, 1)a)], the correction coefficient  $c$  is equal to unity and there is no correction to make.

In the other case, calculate the correction coefficient  $c$  from the formula:

$$c = 1 + \frac{a}{u}$$

where

$a$  is the internal cross-section of the capillary tube;

$u$  is the total internal cross-section of the U-tube (both sides) at the level of the mercury,  $a$  and  $u$  being expressed in the same unit.

NOTE This correction is made necessary by the fact that when there is no overflowing in the course of the test the level of the mercury in the U-tube (reference level for the pressure) rises slightly.

### 8.3 Determination of transmission rate

Prepare a graph by plotting the values of  $h$  in centimetres as a function of the time  $t$  in hours, tenths, etc.

Disregard the initial part of the curve during which the slope  $dh/dt$  increases with time and choose a point on the curve at a value  $t$  such that the slope of the curve is practically constant (straight line) or diminishing very slightly.

Calculate the value of  $dh/dt$  at this point and note the corresponding value of  $h$  in centimetres.

Calculate the transmission rate  $G$ , in cubic centimetres per square metre per 24 h under a pressure difference of 1 atm, from the formula:

$$G = 24 \times \frac{T_o}{T} \times \frac{1}{P_o} \times \frac{10^4}{A} \times \frac{V + 2ah}{H - ch} \times c \frac{dh}{dt} \quad \dots (1)$$

where

$T_o = 273$  K;

$T$  is the temperature of test, in kelvins;

$P_o$  is the normal atmospheric pressure, in atmospheres; therefore  $P_o = 1$ ;

$A$  is the area of the working surface of the test specimen, defined by the gasket, in square centimetres;

$V$  is the initial volume of chamber 2, in cubic centimetres (see 8.1);

$a$  is the internal cross-section of the capillary tube, in square centimetres;

$h$  is the height of the mercury in the capillary read at time  $t$ , in relation to the level at the start of the test, in centimetres;

$H$  is the height of the mercury column corresponding to the atmospheric pressure at the time of the test (barometric height), in centimetres;

$c$  is the correction coefficient, dependent on the apparatus (see 8.2);

$\frac{dh}{dt}$  is the slope of the curve at the point  $t$ , in centimetres per hour.

Calculate the transmission rate, retaining only the number of significant figures corresponding to the accuracy of the measurements, either two or three figures at the most.

NOTE The formula (1) implies that all the factors are expressed in the indicated units.

The basic formula from which these calculations are made is as follows:

$$G = 24 \times \frac{T_o}{T} \times \frac{1}{P_o} \times \frac{10^4}{A} \times \frac{V + 2ah}{P - p} \times \frac{dP}{dt} \quad \dots (2)$$

where

$P$  is the atmospheric pressure at the time of test;

$p$  is the pressure in chamber 2 at time  $t$ ;

$\frac{dP}{dt}$  is the variation of pressure at time  $t$ ;

$P, p$  (and  $dP$ ) are expressed in the same units.

To pass from formula (2) to the practical formula (1), let:

$$P = kH \quad \dots (3)$$

and

$$P = kch \quad \dots (4)$$

$k$  being a constant dependent on the units expressing  $P$  and  $p$  in relation to those expressing  $H$  and  $h$ . This constant has the dimensions of the quotient pressure/length, i.e.  $MT^{-2}L^{-2}$ , and is the pressure exerted by unit height of a mercury column. When  $P$  and  $p$  are measured in centimetres of mercury, and  $H$  and  $h$  in centimetres, then  $k = 1$ .

By replacing in formula (2) successively  $p$  (and  $dP$ ) then  $P$  by the values of formulas (4) and (3), the following formulas are obtained:

$$G = 24 \times \frac{T_o}{T} \times \frac{1}{P_o} \times \frac{10^4}{A} \times \frac{V + 2ah}{H - kch} \times kc \frac{dh}{dt} \quad \dots (5)$$

$$= 24 \times \frac{T_o}{T} \times \frac{1}{P_o} \times \frac{10^4}{A} \times \frac{V + 2ah}{H - ch} \times c \frac{dh}{dt} \quad \dots (6)$$

## 9 Test report

The test report shall include the following particulars:

- a) description of the sample and its mean thickness and, if carried out, the conditioning;
- b) number of test specimens;
- c) details of the apparatus used;
- d) the test gas used, and its relative humidity if applicable;
- e) the temperature of test;
- f) the values of transmission rate calculated for each test specimen and their mean value.

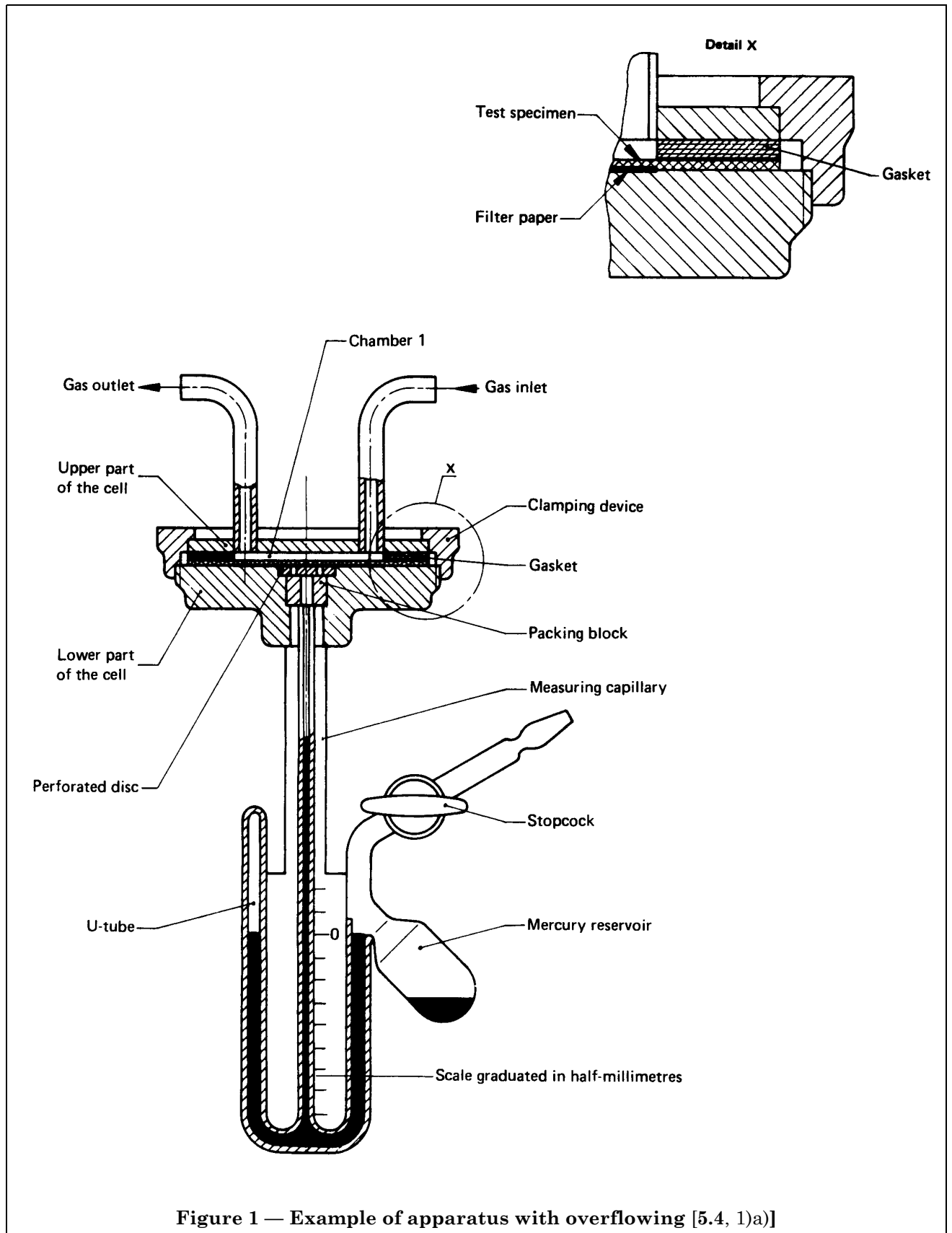

Figure 1 — Example of apparatus with overflowing [5.4, 1)a]

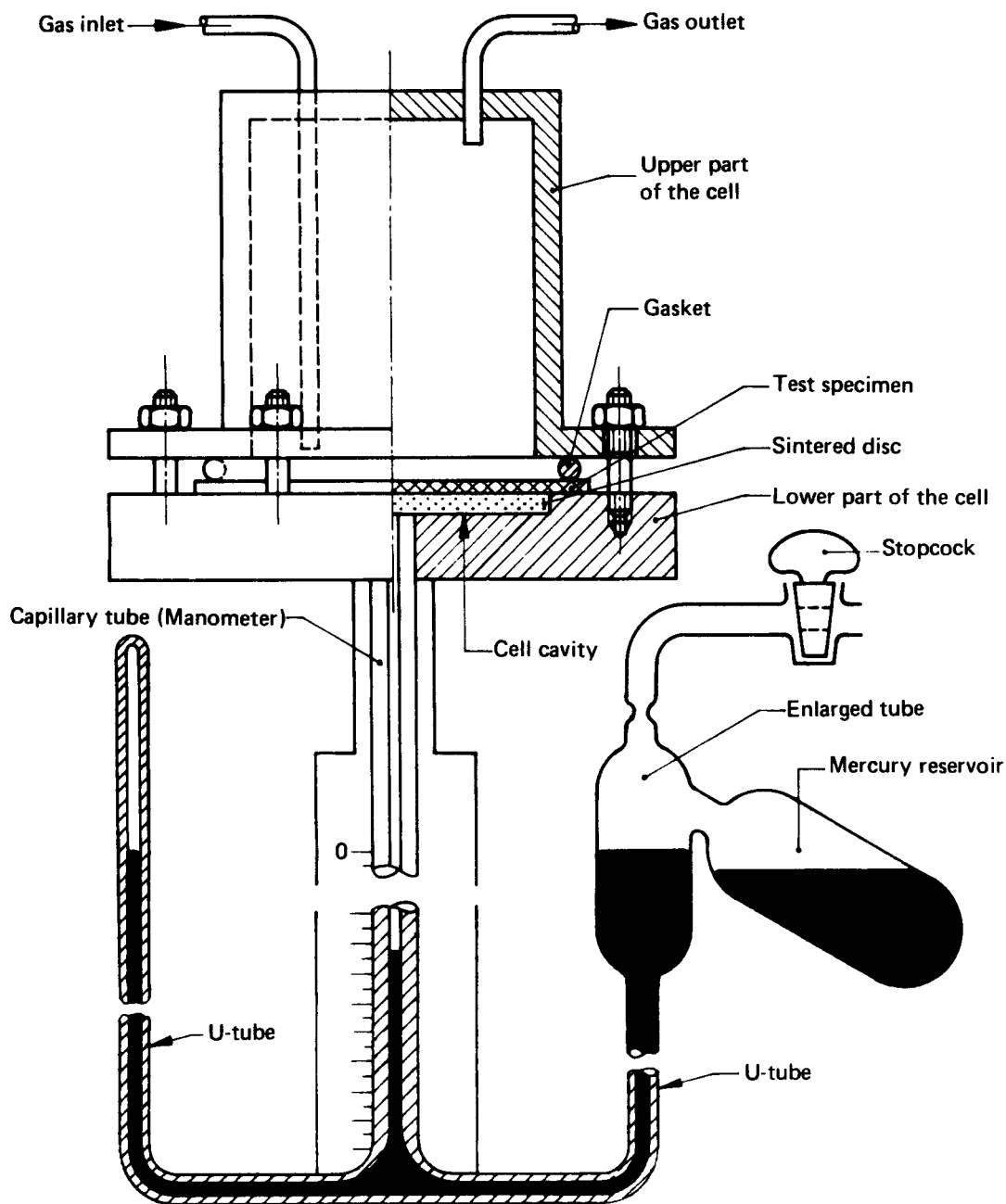

Figure 2 — Example of apparatus without overflowing [5.4, 2]



---

---

## BSI — British Standards Institution

BSI is the independent national body responsible for preparing British Standards. It presents the UK view on standards in Europe and at the international level. It is incorporated by Royal Charter.

### Revisions

British Standards are updated by amendment or revision. Users of British Standards should make sure that they possess the latest amendments or editions.

It is the constant aim of BSI to improve the quality of our products and services. We would be grateful if anyone finding an inaccuracy or ambiguity while using this British Standard would inform the Secretary of the technical committee responsible, the identity of which can be found on the inside front cover. Tel: 020 8996 9000. Fax: 020 8996 7400.

BSI offers members an individual updating service called PLUS which ensures that subscribers automatically receive the latest editions of standards.

### Buying standards

Orders for all BSI, international and foreign standards publications should be addressed to Customer Services. Tel: 020 8996 9001. Fax: 020 8996 7001. Standards are also available from the BSI website at <http://www.bsi-global.com>.

In response to orders for international standards, it is BSI policy to supply the BSI implementation of those that have been published as British Standards, unless otherwise requested.

### Information on standards

BSI provides a wide range of information on national, European and international standards through its Library and its Technical Help to Exporters Service. Various BSI electronic information services are also available which give details on all its products and services. Contact the Information Centre. Tel: 020 8996 7111. Fax: 020 8996 7048.

Subscribing members of BSI are kept up to date with standards developments and receive substantial discounts on the purchase price of standards. For details of these and other benefits contact Membership Administration. Tel: 020 8996 7002. Fax: 020 8996 7001. Further information about BSI is available on the BSI website at <http://www.bsi-global.com>.

### Copyright

Copyright subsists in all BSI publications. BSI also holds the copyright, in the UK, of the publications of the international standardization bodies. Except as permitted under the Copyright, Designs and Patents Act 1988 no extract may be reproduced, stored in a retrieval system or transmitted in any form or by any means – electronic, photocopying, recording or otherwise – without prior written permission from BSI.

This does not preclude the free use, in the course of implementing the standard, of necessary details such as symbols, and size, type or grade designations. If these details are to be used for any other purpose than implementation then the prior written permission of BSI must be obtained.

If permission is granted, the terms may include royalty payments or a licensing agreement. Details and advice can be obtained from the Copyright Manager. Tel: 020 8996 7070.