

BS EN ISO 2553:2013



BSI Standards Publication

# Welding and allied processes — Symbolic representation on drawings — Welded joints

**bsi.**

...making excellence a habit.™

**National foreword**

This British Standard is the UK implementation of EN ISO 2553:2013. It supersedes BS EN 22553:1995 which is withdrawn.

The UK participation in its preparation was entrusted to Technical Committee WEE/1, Definitions and symbols for welding.

A list of organizations represented on this committee can be obtained on request to its secretary.

This publication does not purport to include all the necessary provisions of a contract. Users are responsible for its correct application.

© The British Standards Institution 2013. Published by BSI Standards Limited 2013

ISBN 978 0 580 53308 2

ICS 01.100.20; 25.160.40

**Compliance with a British Standard cannot confer immunity from legal obligations.**

This British Standard was published under the authority of the Standards Policy and Strategy Committee on 31 December 2013.

**Amendments issued since publication**

Date	Text affected
------	---------------

---

English Version

## Welding and allied processes - Symbolic representation on drawings - Welded joints (ISO 2553:2013)

Soudage et techniques connexes - Représentations symboliques sur les dessins - Joints soudés (ISO 2553:2013)

Schweißen und verwandte Prozesse - Symbolische Darstellung in Zeichnungen - Schweiß- und Lötverbindungen (ISO 2553:2013)

This European Standard was approved by CEN on 20 December 2013.

CEN members are bound to comply with the CEN/CENELEC Internal Regulations which stipulate the conditions for giving this European Standard the status of a national standard without any alteration. Up-to-date lists and bibliographical references concerning such national standards may be obtained on application to the CEN-CENELEC Management Centre or to any CEN member.

This European Standard exists in three official versions (English, French, German). A version in any other language made by translation under the responsibility of a CEN member into its own language and notified to the CEN-CENELEC Management Centre has the same status as the official versions.

CEN members are the national standards bodies of Austria, Belgium, Bulgaria, Croatia, Cyprus, Czech Republic, Denmark, Estonia, Finland, Former Yugoslav Republic of Macedonia, France, Germany, Greece, Hungary, Iceland, Ireland, Italy, Latvia, Lithuania, Luxembourg, Malta, Netherlands, Norway, Poland, Portugal, Romania, Slovakia, Slovenia, Spain, Sweden, Switzerland, Turkey and United Kingdom.



EUROPEAN COMMITTEE FOR STANDARDIZATION  
COMITÉ EUROPÉEN DE NORMALISATION  
EUROPÄISCHES KOMITEE FÜR NORMUNG

**CEN-CENELEC Management Centre: Avenue Marnix 17, B-1000 Brussels**

## Foreword

This document (EN ISO 2553:2013) has been prepared by Technical Committee ISO/TC 44 "Welding and allied processes" in collaboration with Technical Committee CEN/TC 121 "Welding", the secretariat of which is held by DIN.

This European Standard shall be given the status of a national standard, either by publication of an identical text or by endorsement, at the latest by June 2014, and conflicting national standards shall be withdrawn at the latest by June 2014.

Attention is drawn to the possibility that some of the elements of this document may be the subject of patent rights. CEN [and/or CENELEC] shall not be held responsible for identifying any or all such patent rights.

This document supersedes EN 22553:1994.

According to the CEN-CENELEC Internal Regulations, the national standards organizations of the following countries are bound to implement this European Standard: Austria, Belgium, Bulgaria, Croatia, Cyprus, Czech Republic, Denmark, Estonia, Finland, Former Yugoslav Republic of Macedonia, France, Germany, Greece, Hungary, Iceland, Ireland, Italy, Latvia, Lithuania, Luxembourg, Malta, Netherlands, Norway, Poland, Portugal, Romania, Slovakia, Slovenia, Spain, Sweden, Switzerland, Turkey and the United Kingdom.

### Endorsement notice

The text of ISO 2553:2013 has been approved by CEN as EN ISO 2553:2013 without any modification.

# Contents

Page

<b>Foreword</b> .....	<b>iv</b>
<b>Introduction</b> .....	<b>v</b>
<b>1 Scope</b> .....	<b>1</b>
<b>2 Normative references</b> .....	<b>1</b>
<b>3 Terms and definitions</b> .....	<b>1</b>
<b>4 Welding symbol</b> .....	<b>4</b>
4.1 General.....	4
4.2 Basic welding symbol.....	4
4.3 Welding symbol systems.....	5
4.4 Elementary symbols.....	5
4.5 Supplementary symbols.....	9
4.6 Arrow line.....	14
4.7 Reference line and weld location.....	16
4.8 Tail.....	19
<b>5 Dimensioning of welds</b> .....	<b>19</b>
5.1 General.....	19
5.2 Cross-sectional dimensions.....	19
5.3 Length dimensions.....	19
5.4 Butt welds.....	20
5.5 Fillet welds.....	21
5.6 Plug welds in circular holes.....	21
5.7 Plug welds in slots.....	21
5.8 Spot welds.....	22
5.9 Seam welds.....	22
5.10 Edge welds.....	22
5.11 Stud welds.....	22
5.12 Overlay welds.....	22
<b>6 Dimensioning of joint preparations</b> .....	<b>34</b>
6.1 General.....	34
6.2 Root gap.....	34
6.3 Included angle.....	34
6.4 Radii and root faces — U and J butt joints.....	35
6.5 Depth of joint preparation.....	35
6.6 Countersink angle for plug and slot welds.....	37
<b>7 Alternative butt weld symbol with required weld quality</b> .....	<b>38</b>
7.1 General.....	38
7.2 Example.....	38
<b>Annex A (informative) Examples of the use of welding symbols</b> .....	<b>39</b>
<b>Annex B (informative) Tolerances and transition points for weld types<sup>[9]</sup></b> .....	<b>50</b>
<b>Annex C (informative) Alternative methods for designating intermittent butt and fillet welds</b> .....	<b>51</b>
<b>Bibliography</b> .....	<b>54</b>

## Foreword

ISO (the International Organization for Standardization) is a worldwide federation of national standards bodies (ISO member bodies). The work of preparing International Standards is normally carried out through ISO technical committees. Each member body interested in a subject for which a technical committee has been established has the right to be represented on that committee. International organizations, governmental and non-governmental, in liaison with ISO, also take part in the work. ISO collaborates closely with the International Electrotechnical Commission (IEC) on all matters of electrotechnical standardization.

The procedures used to develop this document and those intended for its further maintenance are described in the ISO/IEC Directives, Part 1. In particular the different approval criteria needed for the different types of ISO documents should be noted. This document was drafted in accordance with the editorial rules of the ISO/IEC Directives, Part 2. [www.iso.org/directives](http://www.iso.org/directives)

Attention is drawn to the possibility that some of the elements of this document may be the subject of patent rights. ISO shall not be held responsible for identifying any or all such patent rights. Details of any patent rights identified during the development of the document will be in the Introduction and/or on the ISO list of patent declarations received. [www.iso.org/patents](http://www.iso.org/patents)

Any trade name used in this document is information given for the convenience of users and does not constitute an endorsement.

For an explanation on the meaning of ISO specific terms and expressions related to conformity assessment, as well as information about ISO's adherence to the WTO principles in the Technical Barriers to Trade (TBT) see the following URL: [Foreword - Supplementary information](#)

The committee responsible for this document is ISO/TC *Welding and allied processes*, Subcommittee SC 7, *Representation and terms*.

This fourth edition cancels and replaces the third edition (ISO 2553:1992), which has been technically revised.

Requests for official interpretations of any aspect of this standard should be directed to the Secretariat of ISO/TC 44/SC 7 via your national standards body, a complete listing of which can be found at [www.iso.org](http://www.iso.org).

## Introduction

The symbols given in this standard can be used on technical drawings for welded components. Design-related specifications, such as type, thickness, and length of weld, weld quality, surface treatment, filler material and testing specifications, can be indicated directly at the weld by means of the symbols given in this standard. The principals of this standard can be applied to brazed and soldered joints.

Clarity may be improved by references to collective information in the drawings or references to additional design-related documents.

Preparation for production may require detailed welding-related planning. The type of representation described in this standard can be used for this purpose and complemented by additional production-related information (e.g. welding position, welding process, WPS, weld preparation, preheating ...). This information is often given in production-related documents, such as work schedules or welding procedure specifications (WPS).

Technical drawings are intended to clearly and understandably illustrate design-related specifications. Welding-related drawings should be prepared and checked by specially trained personnel (see ISO 14731).

This edition of ISO 2553 recognizes that there are two different approaches in the global market to designate the arrow side and other side on drawings, and allows for either to be used in isolation, to suit a particular market need. Application of either approach identifies a welding symbol in accordance with this International Standard. The approach in accordance with system A is based on ISO 2553:1992. The approach in accordance with system B is based upon standards used by Pacific Rim countries.





# Welding and allied processes — Symbolic representation on drawings — Welded joints

## 1 Scope

This International Standard defines the rules to be applied for symbolic representation of welded joints on technical drawings. This may include information about the geometry, manufacture, quality and testing of the welds. The principles of this standard may also be applied to soldered and brazed joints.

It is recognized that there are two different approaches in the global market to designate the arrow side and other side on drawings. In this International Standard:

- clauses, tables and figures which carry the suffix letter “A” are applicable only to the symbolic representation system based on a dual reference line;
- clauses, tables and figures which carry the suffix letter “B” are applicable only to the symbolic representation system based on a single reference line;
- clauses, tables and figures which do not have the suffix letter “A” or “B” are applicable to both systems.

The symbols shown in this International Standard may be combined with other symbols used on technical drawings, for example to show surface finish requirements.

An alternative designation method is presented which may be used to represent welded joints on drawings by specifying essential design information such as weld dimensions, quality level, etc. The joint preparation and welding process(es) are then determined by the production unit in order to meet the specified requirements.

**NOTE** Examples given in this International Standard, including dimensions, are illustrative only and are intended to demonstrate the proper application of principles. They are not intended to represent good design practices, or to replace code or specification requirements.

## 2 Normative references

The following documents, in whole or in part, are normatively referenced in this document and are indispensable for its application. For dated references, only the edition cited applies. For undated references, the latest edition of the referenced document (including any amendments) applies.

ISO 128 (all parts), *Technical drawings — General principles of presentation*

ISO 129-1, *Technical drawings — Indication of dimensions and tolerances — Part 1: General principles*

ISO 1302, *Geometrical Product Specifications (GPS) — Indication of surface texture in technical product documentation*

ISO 3098-2, *Technical product documentation — Lettering — Part 2: Latin alphabet, numerals and marks*

ISO 4063, *Welding and allied processes — Nomenclature of processes and reference numbers*

ISO/TR 25901:2007, *Welding and related processes — Vocabulary*

## 3 Terms and definitions

For the purposes of this document, the terms and definitions given in ISO/TR 25901 and the following apply.

**3.1  
welding symbol**

symbol consisting of an arrow line and a reference line and which may also include elementary and supplementary symbols, dimensions and/or tail, used on technical drawings to indicate welded joint type, location and joint preparation

Note 1 to entry: See [Clause 4](#).

**3.2  
basic welding symbol**

symbol consisting of an arrow line, reference line and tail used when the joint is not specified and only to indicate that a welded joint is to be made

Note 1 to entry: See [4.2](#).

**3.3  
arrow line**

leader line used to indicate the joint that is to be welded generally drawn at 135° to the reference line

Note 1 to entry: See [4.6](#).

**3.4  
reference line**

part of the welding symbol on which the elementary symbol is located, generally drawn parallel to the bottom edge of the drawing

Note 1 to entry: See [4.7](#).

**3.5  
tail**

V shaped element added to the end of the continuous reference line away from the arrow line

Note 1 to entry: See [4.8](#).

**3.6  
arrow side**

side of the joint to which the arrow line is pointing

Note 1 to entry: See [4.7.2.1](#).

**3.7  
other side**

opposite side of the joint to the arrow side

Note 1 to entry: See [4.7.2.1](#).

**3.8  
elementary symbol**

symbol forming part of the welding symbol and drawn on the reference line to indicate the type of weld and joint preparation

Note 1 to entry: See [4.4](#).

**3.9  
supplementary symbol**

symbol used in conjunction with elementary symbols to convey additional information about the joint

Note 1 to entry: See [4.5](#).

**3.10**  
**complementary information**

non-symbolic information, relevant to the welds being made, which may be included in the tail of the welding symbol

Note 1 to entry: See [4.8](#).

**3.11**  
**intermittent weld**

series of weld elements made at intervals along a joint

[SOURCE: ISO/TR 25901:2007]

Note 1 to entry: See [5.3.2](#).

**3.11.1**  
**chain intermittent weld**

intermittent weld on each side of a joint (usually fillet welds in T and lap joints) arranged so that the welds lie opposite one another along the joint

Note 1 to entry: See [5.3.2.2](#).

**3.11.2**  
**staggered intermittent weld**

intermittent weld on each side of a joint (usually fillet welds in T and lap joints) arranged so that the welds on one side lie opposite to the spaces on the other side along the joint

Note 1 to entry: See [5.3.2.3](#).

**3.12**  
**offset**

distance between the start of welding on one side of a staggered intermittent weld made on both sides of the joint and the start of welding on the other side

Note 1 to entry: See [5.3.2.3](#), [Table 3](#) and [Table 5](#), No 2.6.

**3.13**  
**back run**

final run deposited on the root side of a fusion weld

**3.14**  
**backing weld**

backing in the form of a weld

**3.15**  
**nominal weld length**

design length of a weld

**3.15.1**  
**nominal length of weld elements**

in intermittent welds, the design length of the elements of the weld

**3.16**  
**nominal throat thickness**

*a*

design value of the height of the largest isosceles triangle that can be inscribed in the section of a fillet weld

Note 1 to entry: Other design throat thicknesses may be used, but need to be specified.

**3.17**  
**leg length**

*z*

distance from the actual or projected intersection of the fusion faces and the toe of a fillet weld, measured across the fusion face

**3.18**  
**penetration depth**

<butt welds> thickness of the weld metal excluding any reinforcement

**3.19**  
**deep penetration throat thickness**

*s*

<fillet welds> nominal or effective throat thickness to which a certain amount of fusion penetration is added

**3.20**  
**flare-bevel weld**

butt weld between a joint member with a curved surface and another with a planar surface

Note 1 to entry: See [Table 5](#).

**3.21**  
**flare-V weld**

butt weld between two members with curved surfaces

Note 1 to entry: See [Table 5](#).

**3.22**  
**field weld**

weld made outside workshops usually at the place of final installation

## **4 Welding symbol**

### **4.1 General**

A reference line and arrow line are required elements. Additional elements may be included to convey specific information.

It is preferable that the welding symbol is shown on the same side of the joint that the weld is to be made, i.e. the arrow side (see [4.6](#)).

The thickness of the arrow lines, reference line, elementary symbols and lettering shall be in accordance with ISO 128 and ISO 3098-2.

In order not to overburden drawings, reference should be made to notes in the drawing or other design-related documents.

### **4.2 Basic welding symbol**

If joint details are not specified and the only requirement is to indicate that a joint is to be welded, the basic symbol shown in [Figure 1](#) may be used. In this case, a dual reference line is not required for system A (see 4.6.1A) as no details concerning the weld are being conveyed.

The basic welding symbol shall comprise an arrow line, reference line and a tail.

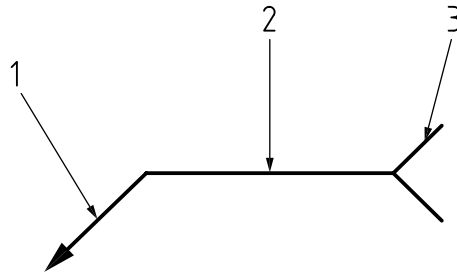

**Key**

- 1 arrow line
- 2 reference line
- 3 tail

NOTE This symbol is often used to indicate the location of tack welds.

**Figure 1 — Basic welding symbol (joint details and type not specified)**

### 4.3 Welding symbol systems

This International standard recognizes two different systems, A and B, to designate the arrow side and other side on drawings.

The symbolic representation in system A is based on a dual reference line consisting of a continuous line and a dashed line (see 4.7).

The symbolic representation in system B is based on a single reference line (see 4.7).

Clauses, Tables and Figures which carry the suffix “A” or “B” are applicable only to system A or system B respectively.

Clauses, tables and figures which do not have a suffix are applicable to both systems.

System A and B shall not be mixed and drawings shall clearly indicate which system is used including units of measurement in accordance with ISO 129-1.

Examples of comprehensive welding symbols showing the location of elements are given in [Figure A.1](#).

### 4.4 Elementary symbols

#### 4.4.1 General

Elementary symbols, in accordance with [Table 1](#), can be added to the reference line in both systems A and B to indicate the type of weld to be made.

Elementary symbols form part of the welding symbol and shall be drawn attached to the reference line generally at the mid-point.

Elementary symbols may be complemented by:











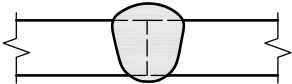

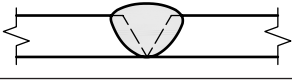
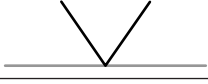
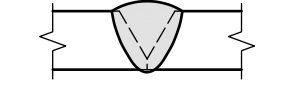
- supplementary symbols (see 4.5 and [Table 3](#));
- dimensions (see [Clause 5](#));
- complementary information.

The orientation of the elementary symbols shall not be changed to that shown.

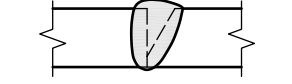
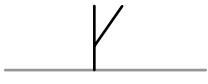
[Annex B](#) gives guidance on tolerances and transition points for butt welds, edge welds and fillet welds.

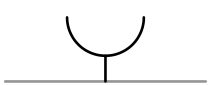
If clear illustration by means of symbols is not possible, cross sections of the welds may be drawn and dimensioned.

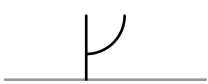
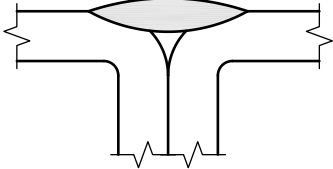
**Table 1 — Elementary symbols**

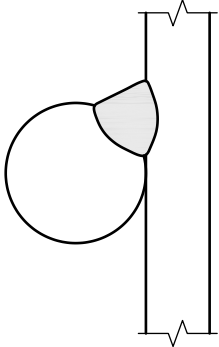
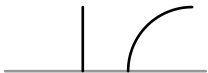



No.	Designation	Illustration (dashed lines show joint preparation prior to welding)	Symbol <sup>a</sup>
1	Square butt <sup>b</sup>		
2	Single-V butt <sup>b</sup>		
3	Single-V butt with broad root face <sup>b</sup>		
4	Single-bevel butt <sup>b</sup>		
5	Single-bevel butt with broad root face <sup>b</sup>		
6	Single-U butt <sup>b</sup>		
7	Single-J butt <sup>b</sup>		
8	Flare V		
9	Flare bevel		

<sup>a</sup> The grey line is not part of the symbol. It indicates the position of the reference line.

<sup>b</sup> Butt welds are full penetration unless otherwise indicated by dimensions on the welding symbol or by reference to other information, for example the WPS.

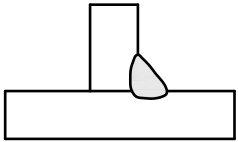
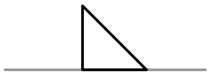
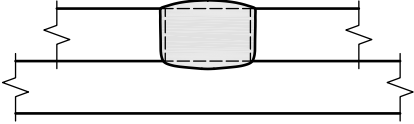
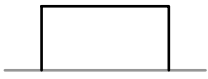
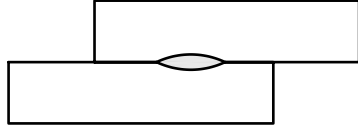
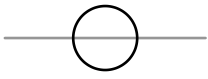
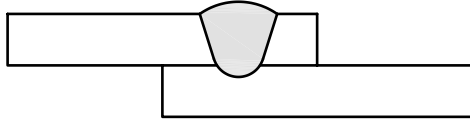
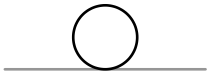
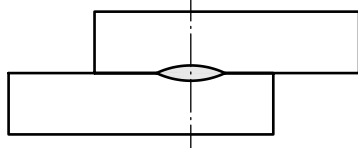
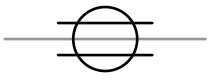
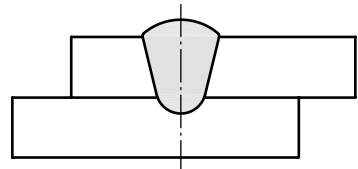
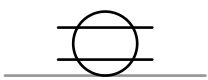
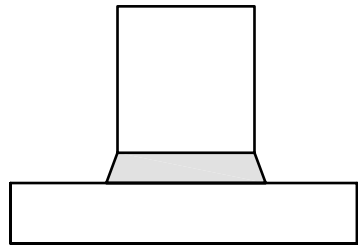
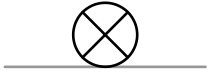
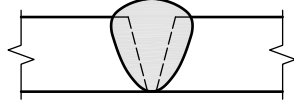

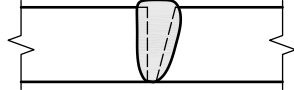



<sup>c</sup> May be used for joints with more than 2 members.

Table 1 (continued)

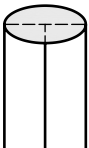
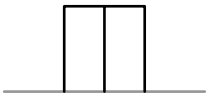
No.	Designation	Illustration (dashed lines show joint preparation prior to welding)	Symbol <sup>a</sup>
10	Fillet		
11	Plug (in slots or circular holes)		
12	Resistance spot (including projection welding in system A)		
13	Fusion spot (and projection welding in system B)		
14	Resistance seam		
15	Fusion seam		
16	Stud		
17	Steep-flanked single-V butt <sup>b</sup>		
18	Steep-flanked single-bevel butt <sup>b</sup>		

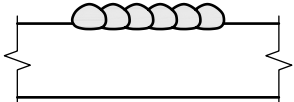
<sup>a</sup> The grey line is not part of the symbol. It indicates the position of the reference line.  
<sup>b</sup> Butt welds are full penetration unless otherwise indicated by dimensions on the welding symbol or by reference to other information, for example the WPS.  
<sup>c</sup> May be used for joints with more than 2 members.

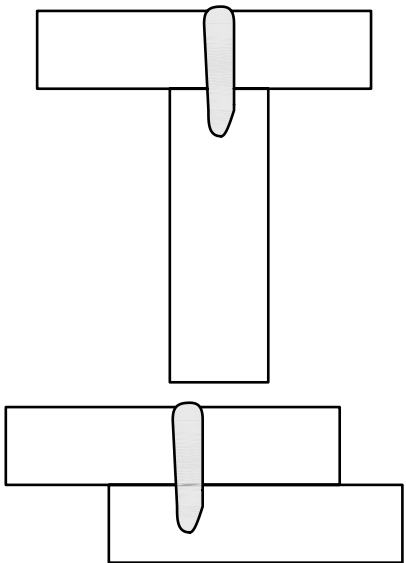
**Table 1** (continued)

No.	Designation	Illustration (dashed lines show joint preparation prior to welding)	Symbol <sup>a</sup>
19	Edge <sup>c</sup>		
20	Flanged butt/corner weld		
21	Overlay		
22	Stake <sup>c</sup>		
<p><sup>a</sup> The grey line is not part of the symbol. It indicates the position of the reference line.</p> <p><sup>b</sup> Butt welds are full penetration unless otherwise indicated by dimensions on the welding symbol or by reference to other information, for example the WPS.</p> <p><sup>c</sup> May be used for joints with more than 2 members.</p>			

#### 4.4.2 Combinations of elementary symbols

Elementary symbols may be combined as required to represent particular weld configurations.

#### 4.4.3 Double-sided butt welds

The elementary symbols shall be arranged opposite each other on the reference line, including all required information, when used to represent symmetrical welds.

In the case of symmetrical double-sided welds with identical symbols and dimensions, the dashed reference line should be deleted for system A (see [Table 2](#)).

An example of an asymmetrical double-sided weld is shown in [Table A.3](#).

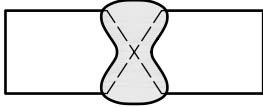
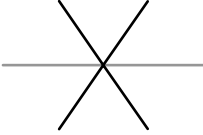
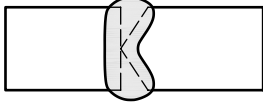
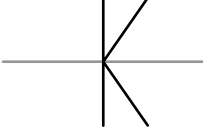
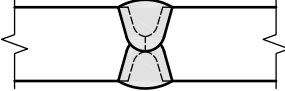
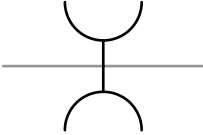
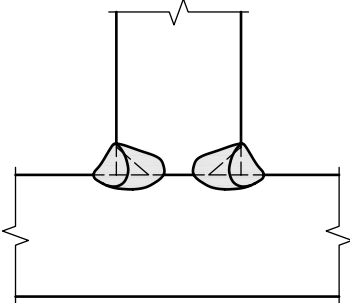
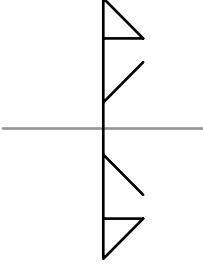

**Table 2 — Combined elementary symbols to represent double-sided welds**

No.	Weld type	Illustration of weld <sup>a</sup>	Symbol <sup>b</sup>
1	Double-V butt		
2	Double bevel butt		
3	Double-U butt		
4	Double bevel butt (with broad root face) and fillet welds		
<p><sup>a</sup> Welds may be partial or full penetration which is to be indicated by dimensions on the welding symbol (see <a href="#">Table 5</a>) or by reference to other information, for example the WPS.</p> <p><sup>b</sup> The grey line is not part of the symbol. It indicates the position of the reference line.</p>			

## 4.5 Supplementary symbols

### 4.5.1 General

Additional information concerning the required joint may be provided by the use of supplementary symbols in accordance with [Table 3](#). Supplementary symbols can, for example, provide information about the shape of the weld or how the welded joint shall be made.

Table 3 — Supplementary symbols

No.	Designation	Symbol <sup>a</sup>	Application example <sup>a</sup>	Illustration of weld
1	Flat-finished flush <sup>b</sup>			
2	Convex <sup>b</sup>			
3	Concave <sup>b</sup>			
4	Toes blended smoothly <sup>c</sup>			No example
5	a) Back run <sup>d</sup> (made after the single-V butt weld)			
	b) Backing weld <sup>d</sup> (made before the single-V butt weld)			
6	Specified root reinforcement (butt welds) <sup>e</sup>			
7a	Backing (unspecified)			
7b	Permanent backing <sup>f</sup>			
7c	Removable/temporary backing <sup>f</sup>			
8	Spacer			

<sup>a</sup> The grey line is not part of the symbol and is included to show the position of symbol on reference line and/or the arrow line only.

<sup>b</sup> Welds that require approximately flush or convex faces without post weld finishing are specified by use of the flush or convex contour symbol.

Welds to be finished flush or convex by post weld finishing or that require a flat but not flush surface require additional information, e.g. addition of a note in the tail of the welding symbol

Other symbols in accordance with ISO 1302 may be used to specify surface finish.

<sup>c</sup> The toes shall be blended smoothly by welding or finishing. Processing details may be specified in the work instructions or WPS.

<sup>d</sup> The weld run sequence may be indicated on the drawing e.g. by use of multiple reference lines, a note in the tail or by reference to a weld procedure specification.

<sup>e</sup> In system B, also used to designate flanged butt/corner welds (see 4.5.5.6)

<sup>f</sup> M = material to be part of the final welded joint, MR = material to be removed after welding. Further information on the material can be included in the tail or elsewhere.

<sup>g</sup> Explanations of *a*, *z*, *n*, *l* and (*e*) are given in [Clause 5](#).

Table 3 (continued)



No.	Designation	Symbol <sup>a</sup>	Application example <sup>a</sup>	Illustration of weld
9	Consumable insert			 <p>a) Joint showing insert in place</p> <p>b) Welded joint showing root bead (insert incorporated into root). Single V but weld not shown</p>
10	Weld all-around			 <p>Example A</p> <p>Example B</p> <p>Example C</p>
<p><sup>a</sup> The grey line is not part of the symbol and is included to show the position of symbol on reference line and/or the arrow line only.</p> <p><sup>b</sup> Welds that require approximately flush or convex faces without post weld finishing are specified by use of the flush or convex contour symbol.</p> <p>Welds to be finished flush or convex by post weld finishing or that require a flat but not flush surface require additional information, e.g. addition of a note in the tail of the welding symbol</p> <p>Other symbols in accordance with ISO 1302 may be used to specify surface finish.</p> <p><sup>c</sup> The toes shall be blended smoothly by welding or finishing. Processing details may be specified in the work instructions or WPS.</p> <p><sup>d</sup> The weld run sequence may be indicated on the drawing e.g. by use of multiple reference lines, a note in the tail or by reference to a weld procedure specification.</p> <p><sup>e</sup> In system B, also used to designate flanged butt/corner welds (see 4.5.5.6)</p> <p><sup>f</sup> M = material to be part of the final welded joint, MR = material to be removed after welding. Further information on the material can be included in the tail or elsewhere.</p> <p><sup>g</sup> Explanations of <i>a</i>, <i>z</i>, <i>n</i>, <i>l</i> and (<i>e</i>) are given in <a href="#">Clause 5</a>.</p>				

Table 3 (continued)

No.	Designation	Symbol <sup>a</sup>	Application example <sup>a</sup>	Illustration of weld
11	Weld between two points			
12	Field weld			No example
13	Staggered intermittent welds <sup>g</sup>			

<sup>a</sup> The grey line is not part of the symbol and is included to show the position of symbol on reference line and/or the arrow line only.

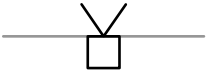
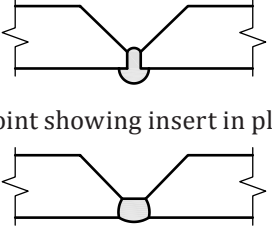
<sup>b</sup> Welds that require approximately flush or convex faces without post weld finishing are specified by use of the flush or convex contour symbol.

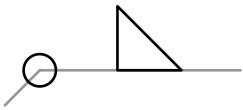
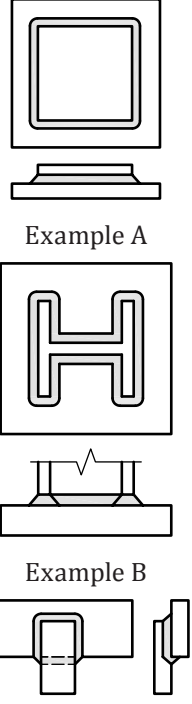
Welds to be finished flush or convex by post weld finishing or that require a flat but not flush surface require additional information, e.g. addition of a note in the tail of the welding symbol

Other symbols in accordance with ISO 1302 may be used to specify surface finish.

<sup>c</sup> The toes shall be blended smoothly by welding or finishing. Processing details may be specified in the work instructions or WPS.

<sup>d</sup> The weld run sequence may be indicated on the drawing e.g. by use of multiple reference lines, a note in the tail or by reference to a weld procedure specification.

<sup>e</sup> In system B, also used to designate flanged butt/corner welds (see 4.5.5.6)

<sup>f</sup> M = material to be part of the final welded joint, MR = material to be removed after welding. Further information on the material can be included in the tail or elsewhere.

<sup>g</sup> Explanations of *a*, *z*, *n*, *l* and *(e)* are given in [Clause 5](#).

#### 4.5.2 Weld all-around symbol

The weld all-around symbol, added at the junction of the arrow and reference lines, may be used to designate a continuous weld, single or double-sided, extending around a series of connected joints (see [Table 3](#)).

The series of joints may involve different directions and may lie in more than one plane but the weld shall always be of the same type and dimensions.

The weld all-around symbol shall not be used if:

- the weld does not start and end at the same point, i.e. it is not continuous;
- the weld type changes, for example from a fillet weld to a butt weld;
- the dimensions change, for example the nominal throat thickness of a fillet weld. In this case, each weld shall be identified using a separate welding symbol;

NOTE The weld all-around symbol is not used to indicate that welds are to be made everywhere.

Welds extending around the circumference of a circular section/hole or slot do not require the use of the weld all-around symbol to specify a continuous weld.

#### 4.5.3 Welds of the same type made from point to point

The weld between two points symbol may be used to designate a continuous weld, of the same type, extending between two points. In this case, the weld does not start and stop at the same point, and the weld all around symbol shall not be used (see [Table 3](#)). The end points of the weld shall be clearly indicated and the welding symbol shall clearly indicate the joint to be welded.

[Figure 2](#) gives an example of how a continuous weld extending around a series of connected points but where the weld does not start and end at the same point, can be designated by one welding symbol.

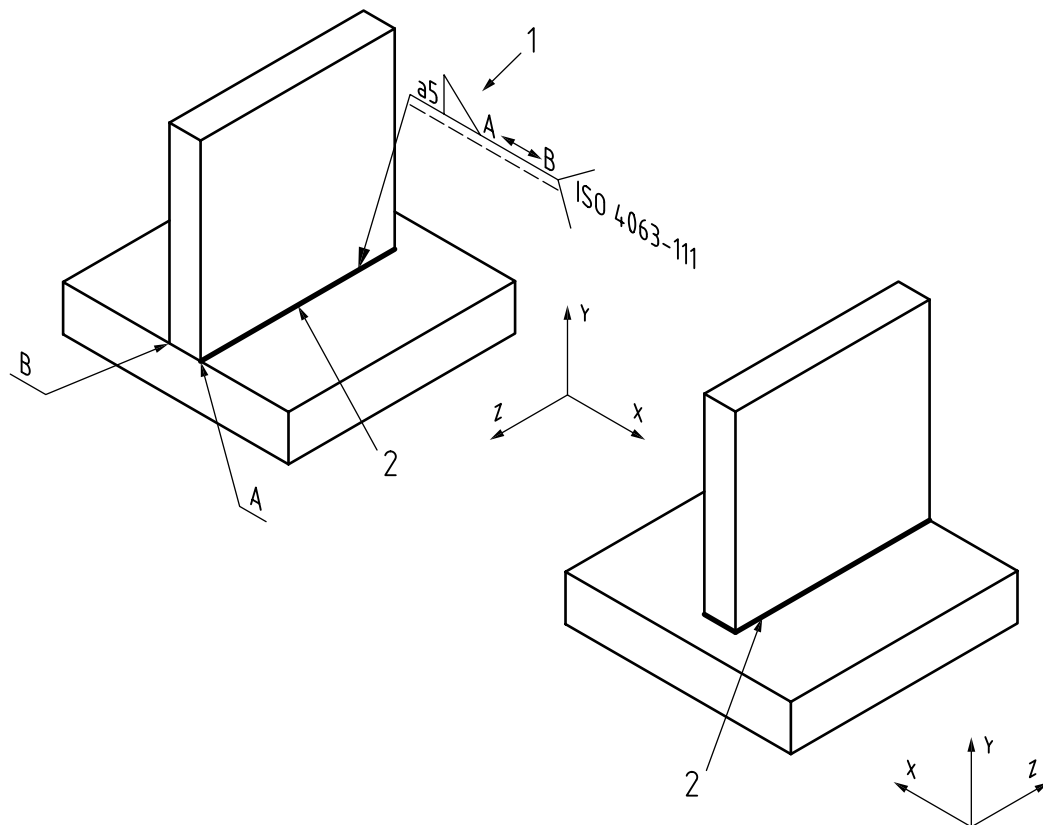

#### Key

- 1 welding symbol
- 2 visual response (welded in accordance with the welding symbol)
- A, B weld end positions

There is no weld from point B to point A (fillet weld not possible).

Any identifier may be used to identify the points between welds e.g. A, B and X, Y etc.

**Figure 2 — Example of a welding symbol for a fillet weld made between two points A and B**

#### 4.5.4 Field welds

Field welds shall be specified by adding the field weld symbol at the junction of the arrow and reference lines (see [Table 3](#)). The symbol shall be placed perpendicularly to and above the reference line. The symbol applies to the whole welding symbol.

#### 4.5.5 Root reinforcement – butt welds made from one side

The root reinforcement symbol shall only be used when complete joint penetration plus a specified minimum root reinforcement dimension is required in butt welds made from one side (see [Figure 3](#)).

The root reinforcement symbol shall be placed opposite the elementary symbol and on the other side of the reference line.

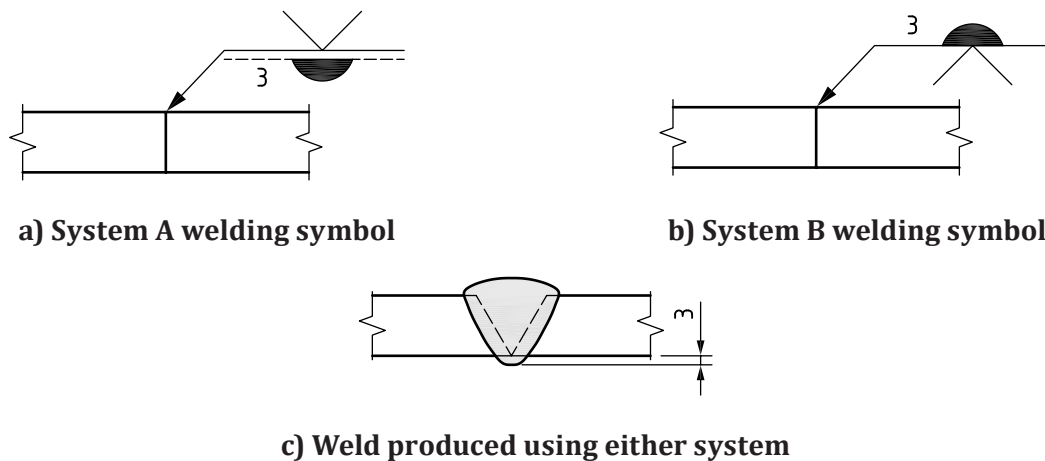

Figure 3 — Example of a weld with specified root reinforcement

#### 4.5.6 Welds on flanged butt and flanged corner joints

Welds on flanged butt and flanged corner joints shall be specified using the symbols shown in [Table 4](#).

### 4.6 Arrow line

#### 4.6.1 General

An arrow line shall be used to indicate the joint to be welded.

The arrow line shall:

- point to and shall be in contact with a solid line comprising part of the joint on the drawing (visible line);
- be drawn at an angle to and joined to a reference line and completed with a closed filled arrowhead.

The arrow line may be joined to either end of the reference line.

Table 4 — Welds on flanged butt and flanged corner joints

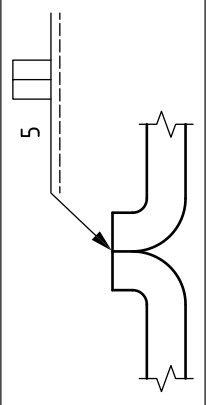
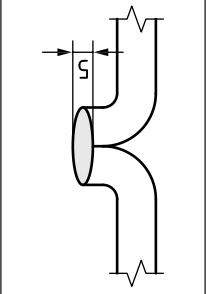
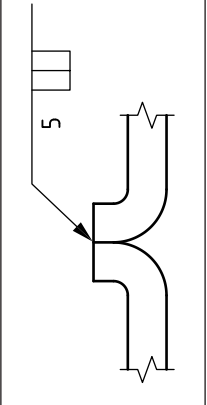
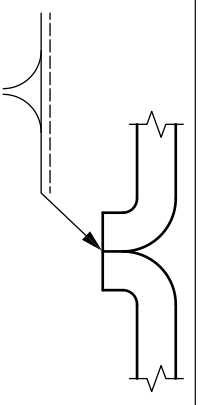
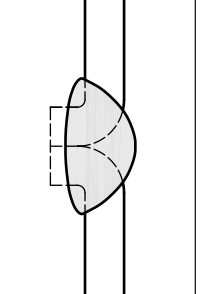
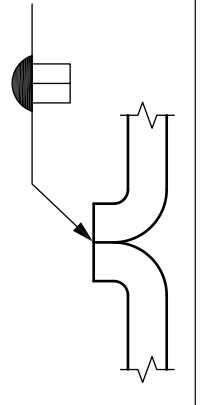
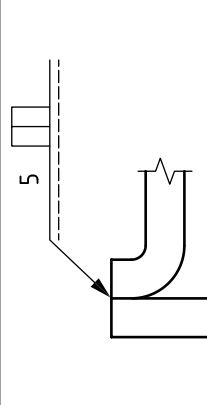
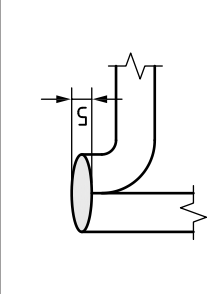
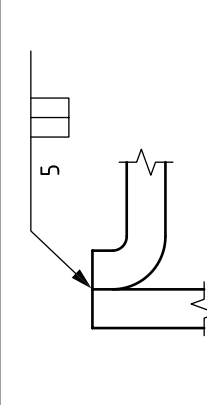
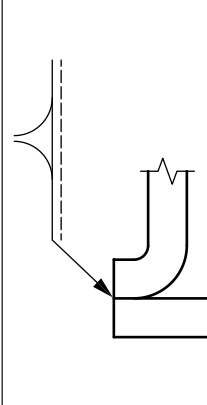
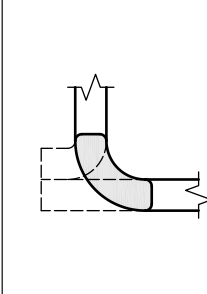
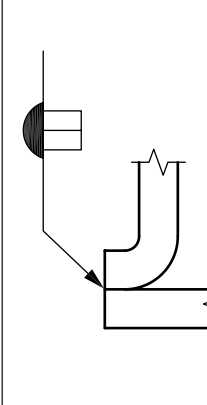
No.	Weld type	System A welding symbol	Illustration of weld	System B welding symbol
<b>FLANGED BUTT JOINTS</b>				
1	Edge			
2	Flanged butt			
<b>FLANGED CORNER JOINTS</b>				
3	Edge			
4	Flanged corner			

#### 4.6.2 Multiple arrow lines

Two or more arrow lines may be combined with a single reference line to indicate the locations of identical welds (see [Figure 4](#)).

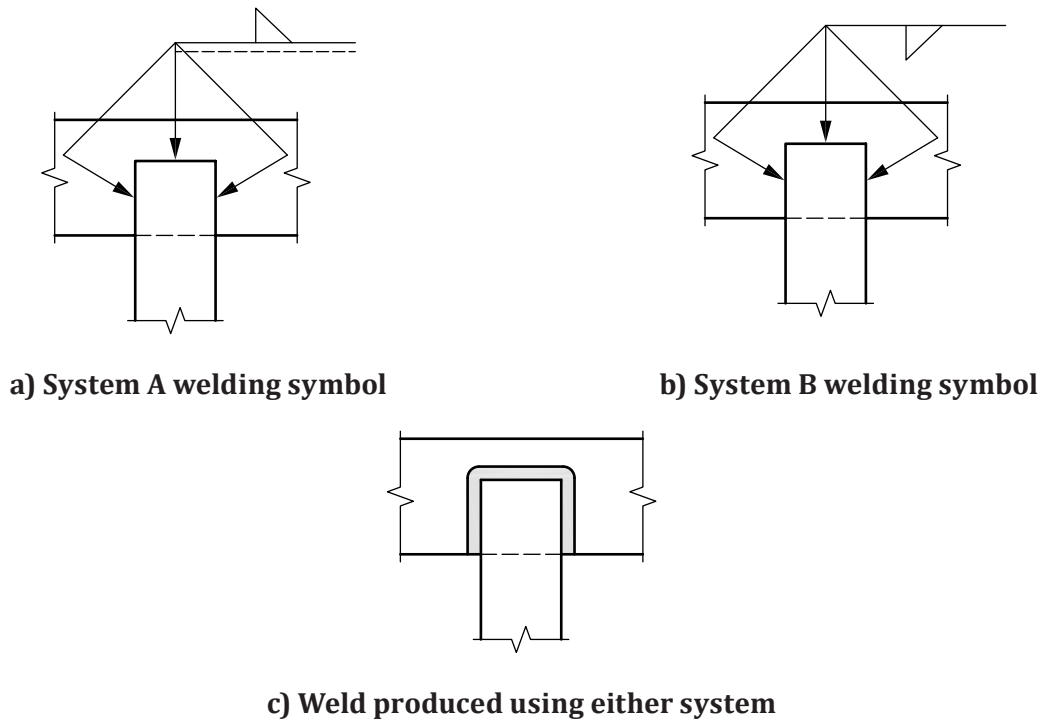

Figure 4 — Examples of use of multiple arrow lines

#### 4.6.3 Broken arrow line

For butt welds in plates (excluding T-butt welds) when a specific joint member is required to be prepared (e.g. single-bevel or single-J butt welds), the arrow line shall have a break and point toward that member.

The arrow line need not be broken if it is obvious or if there is no preference as to which member is to be prepared.

Examples of the use of broken arrow lines are given in [Table A.1](#).

### 4.7 Reference line and weld location

#### 4.7.1 Reference line

The reference line when combined with elementary symbols, is used to indicate the side of the joint on which the weld is to be made.

NOTE The reference line can be drawn parallel to the side edge of the drawing (whole welding symbol rotated by 90°) but should only be done when space does not permit drawing parallel to the bottom edge.



**4.7.1A Reference line — System A:** The reference line consists of two parallel lines of equal length: a continuous line and a dashed line (see Examples in [Annex A](#)).

The dashed line may be drawn above or below the continuous line but shall preferably be drawn below.

The dashed line should be omitted for symmetrical welds and for spot and seam welds made at the interface between two components.

**4.7.1B Reference line — System B:** The reference line shall be drawn as a continuous line (see Examples in [Annex A](#)).

## 4.7.2 Weld location

### 4.7.2.1 Arrow side/Other side

The arrow side is the side of the joint to which the arrowhead is pointing (see [Figure 5](#)).

The other side is the opposite side of the joint to which the arrowhead is pointing. The arrow side and other side always form part of the same joint.

The other side of a joint shall not be confused with a hidden weld forming part of a different joint.

Examples of how to designate welds on the arrow side and other side of joints are given in [Table A.2](#).

**4.7.2.1A Arrow side/Other side — System A:** Elementary symbols shall be located on the continuous line when the weld is to be made on the arrow side of the joint.

Elementary symbols shall be located on the dashed (identification) line when the weld is to be made on the other side of the joint.

**4.7.2.1B Arrow side/Other side — System B:** Elementary symbols shall be located below the reference line when the weld is to be made on the arrow side of the joint.

Elementary symbols shall be located above the reference line when the weld is to be made on the other side of the joint.

NOTE 1 In system A, the component of the reference line on which the elementary symbol is placed determines the side of the joint which is to be welded - the dashed line can be drawn above or below the solid line.

NOTE 2 In system B, the position of the elementary symbol above or below the reference line determines the side of the joint on which the weld is made

### 4.7.2.2 Plug, slot, spot, seam and projection welds

The arrow line shall point to and be in contact with the outer surface of one of the joint members, at the centreline of the required weld.

In the case of welds made at the interface between two members, the elementary symbol shall be placed centrally on the reference line (see [Table A.2](#)) and there is no arrow side/other side relevance. In this case, the dashed reference line may be omitted from system A welding symbols.

**4.7.2.2A Projection welds — System A:** The arrow line shall point to the sheet containing the projection and the elementary symbol shall be placed centrally on the reference line (see [Table A.2](#)). The projection welding process shall be clearly identified e.g. in the tail (ISO 4063-23).

**4.7.2.2B Projection welds — System B:** The arrow line shall point to the sheets to be welded and the elementary symbol shall be placed above or below the reference line to designate which sheet contains the projection (see [Table A.2](#)). The projection welding process shall be identified e.g. in the tail (PW).

### 4.7.3 Multiple reference lines

Two or more reference lines can be used to indicate a series of operations. The first operation shall be specified on the reference line closest to the arrowhead. Subsequent operations shall be specified sequentially on the other reference lines (see Figure 6).

NOTE For joints requiring more than one weld type, combined symbols may also be used (see Table 2).

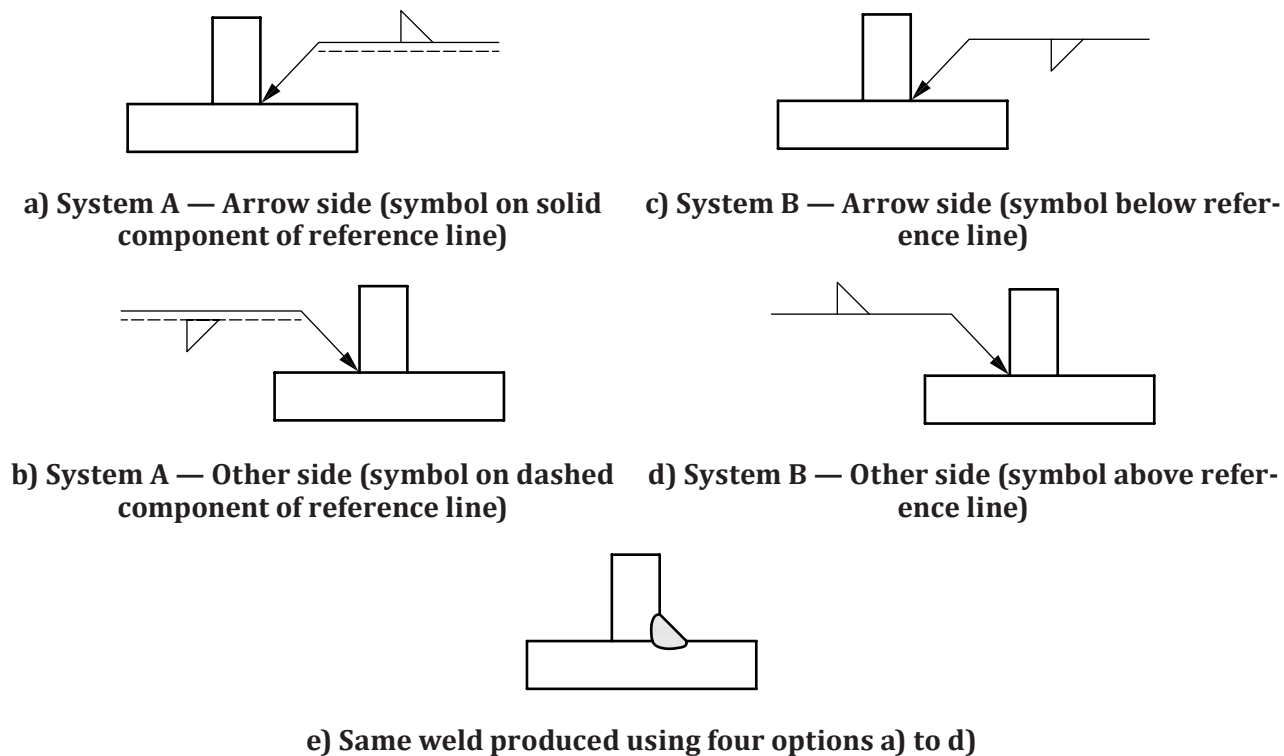
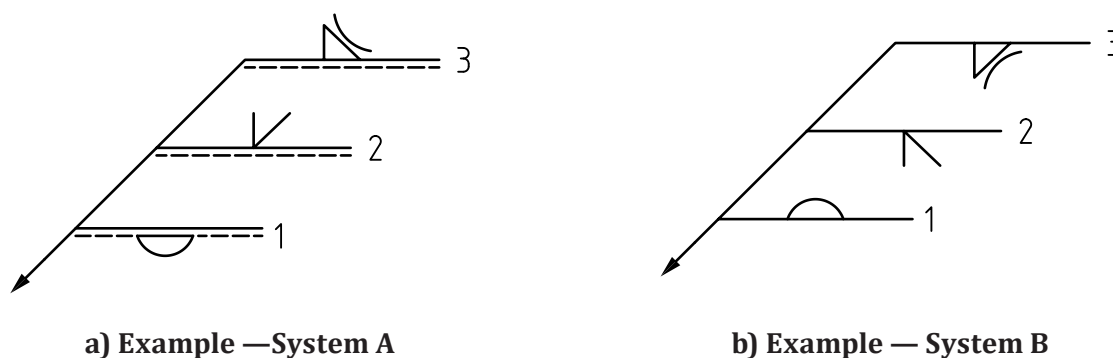

Figure 5 — Examples of welding symbols to illustrate arrow side and other side



**Key**

- 1 first operation
- 2 second operation
- 3 third operation

1, 2 and 3 are shown to indicate the order of the welding operations and are not to be included on drawings.

Figure 6 — Multiple reference lines

## 4.8 Tail

The tail is an optional element which may be added to the end of the continuous reference line (see [Figure 7](#)) where additional complementary information is included as part of the welding symbol, for example:

- a) quality level for example in accordance with ISO 5817, ISO 10042, ISO 13919 etc.;
- b) the welding process, reference number in accordance with ISO 4063 or abbreviation;
- c) filler material for example in accordance with ISO 14171, ISO 14341, etc.;
- d) welding position for example in accordance with ISO 6947;
- e) supplementary information to be considered when making the joint

The information shall be listed and separated by a forward slash (/), [see [Figure 7 a](#)].

A closed tail shall only be used to indicate reference to a specific instruction e.g. reference to a welding procedure specification (WPS), welding procedure qualification record (WPQR) or other document [see [Figure 7 b](#)].

Repetition of additional information on symbols on a drawing shall be avoided. A single general note on the drawing shall be used instead.

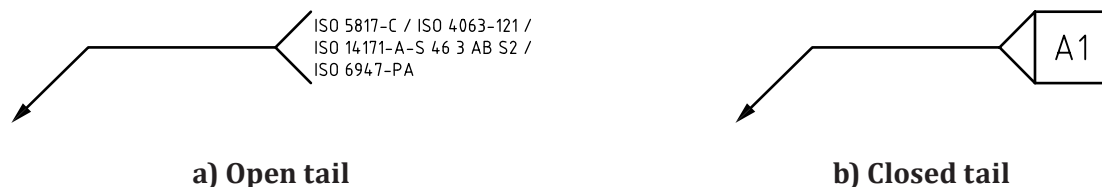

**Figure 7 — Examples of the use of a tail on welding symbols**

## 5 Dimensioning of welds

### 5.1 General

Dimensions shall be specified on the same side of the reference line as the associated elementary symbol (see [Table 5](#) and [Figure A.1](#)).

Drawings shall clearly indicate the units of measurement. Dual units of measure shall be avoided. If it is desired to show conversions from one system of measure to another, a table of conversions should be included on the drawing.

### 5.2 Cross-sectional dimensions

Cross-sectional dimensions shall be placed to the left of the elementary symbol. Letters shall only be combined with cross-sectional dimensions for fillet welds (see [5.5](#)).

### 5.3 Length dimensions

#### 5.3.1 General

Nominal weld length dimensions shall be placed to the right of the elementary symbol.

In the absence of a length dimension, the weld shall be continuous along the entire length of the joint except when using the weld from point to point symbol where the weld extends only between the identified points.

Start and end points of welds that are not continuous along the entire length of the joint shall not be part of the welding symbol but indicated clearly as part of the drawing.

### 5.3.2 Intermittent welds

#### 5.3.2.1 General

Dimensions of intermittent welds shall be placed to the right of the elementary symbol (see [Table 5](#)):

- a) number of weld elements,  $n$
- b) length of weld elements,  $l$
- c) spacing between weld elements,  $e$  (in parentheses)

A multiplication symbol shall be placed between the number of elements,  $n$ , and the length of the weld elements,  $l$ . If the number of weld elements is not specified, the intermittent weld shall be made along the whole length of the joint.

NOTE Other methods, commonly used by Pacific Rim countries, for designating intermittent welds are shown in [Annex C](#).

#### 5.3.2.2 Chain intermittent welds

Chain intermittent welds made on both sides of the joint shall include all information for welds made on both sides of the joint.

#### 5.3.2.3 Staggered intermittent welds

Staggered intermittent welds made on both sides of the joint, shall be designated using the “Z” symbol across the reference line (see [Table 3](#), item 13). In the absence of any information concerning the offset, the centres of the weld elements on one side of the joint shall correspond with the centres of the gaps on the opposite side of the joint. Otherwise, the offset shall be specified in the tail or elsewhere.

#### 5.3.2.4 Extent of welding

Additional weld lengths at the ends of intermittent welds shall be specified using separate welding symbols.

Unwelded lengths at the ends of intermittent welds shall be specified on the drawing.

## 5.4 Butt welds

### 5.4.1 Penetration depth

The required penetration depth shall be placed to the left of the elementary symbol (see [Table 5](#), No. 1).

In the absence of any cross-sectional dimension, butt welds shall always be full penetration.

Where joint geometry or joint preparation are not specified, an alternative symbol can be used to represent butt welds on drawings by specifying the required weld quality — see [Clause 7](#).

Where a specified root reinforcement is required, the minimum dimension of the root reinforcement shall be placed to the left of the root reinforcement symbol (see [Figure 3](#)).

### 5.4.2 Double-sided welds

In double-sided butt welds, each weld shall be separately dimensioned.

NOTE Full penetration symmetrical butt welds do not need to be dimensioned.

### 5.4.3 Flanged butt welds

Flanged butt welds are always full penetration welds (the raised edges are completely melted). These welds require no dimensioning.

### 5.4.4 Flare bevel and flare-V butt welds

Flare bevel and flare-V butt welds shall always be dimensioned. Examples of how to dimension these types of weld are given in [Table 5](#), No 1.6 and 1.7.

## 5.5 Fillet welds

### 5.5.1 Weld size

The letter,  $a$ , nominal throat thickness, or  $z$ , leg length, shall be placed in front of the dimension to the left of the elementary symbol (see [Table 5](#), No. 2.1).

For fillet welds with unequal leg lengths the dimensions of each leg shall be included, preceded by the letter  $z$ , e.g.  $z_14 z_28$ . If the required leg lengths cannot be identified clearly using the welding symbol, additional sketches or indications shall be given on the drawing or in other documents. See [Table 5](#), No. 2.3.

For fillet welds made on both sides of a joint, the dimensions of both welds shall be specified even if they are identical (symmetrical).

### 5.5.2 Deep penetration fillet welds

The letter,  $s$ , shall be placed in front of the required deep penetration throat thickness. This shall be placed in front of the nominal throat thickness,  $a$ , and its dimension as shown in [Table 5](#), No. 2.2.

## 5.6 Plug welds in circular holes

The diameter symbol,  $d$ , shall be placed in front of the required plug weld diameter at the faying surface, and to the left of the plug weld symbol (see [Table 5](#), No. 3).

If plug welds are to be partially filled, the depth of filling shall be indicated inside the elementary symbol. In the absence of a depth dimension, the plug shall be completely filled (see [Table 5](#), No. 3.1 and No. 3.2).

Intermittent welds shall be designated additionally with the number, and centre-to-centre spacing of welds to the right of the elementary symbol (see [Table 5](#), No. 3.3).

## 5.7 Plug welds in slots

The required weld width,  $c$ , at the faying surface, shall be placed to the left of the plug weld symbol (see [Table 5](#), No. 4).

If plug welds are to be partially filled, the depth of filling shall be indicated inside the elementary symbol (see [Table 5](#), No. 4.2). In the absence of a depth dimension, the slot shall be completely filled.

Intermittent welds shall be designated additionally with the number, length and spacing of weld elements to the right of the elementary symbol (see [Table 5](#), No. 4.3).

NOTE The plug weld symbol is not used to designate fillet welds in holes or slots.

## 5.8 Spot welds

The required spot weld diameter,  $d$ , shall be placed to the left of the spot weld symbol (see [Table 5](#), No. 5).

Welds in series shall be designated with the number, and spacing of welds to the right of the elementary symbol (see [Table 5](#), No. 5.1 and No. 5.2).

## 5.9 Seam welds

The required weld width,  $c$ , at the faying surface, shall be placed to the left of the seam weld symbol (see [Table 5](#), No. 6).

Intermittent welds shall be additionally designated with the number, length and spacing of weld elements to the right of the elementary symbol (see [Table 5](#), No. 6.1).

## 5.10 Edge welds

The required weld metal thickness of the edge weld shall be placed to the left of the edge weld symbol (see [Table 5](#), No. 7).

## 5.11 Stud welds

The required stud diameter,  $d$ , shall be placed to the left of the stud weld symbol (see [Table 5](#), No. 8).

Welds in series shall be designated with their number and spacing to the right of the elementary symbol.

## 5.12 Overlay welds

The required overlay thickness shall be placed to the left of the overlay welding symbol (see [Table 5](#), No. 9).

Table 5 — Weld dimensions



No.	Weld type	Illustration	Symbol <sup>a</sup>	Comments
1	BUTT			
1.1	Full penetration			<p><math>s</math> = Penetration depth</p> <p>NOTE 1 No dimension to the left of the elementary symbol indicates butt welds shall be full penetration.</p> <p>NOTE 2 No dimension to the right of the elementary symbol indicates butt welds shall be continuous.</p>
1.2	Partial penetration			<p><math>s</math> = penetration depth</p> <p>Letter <math>s</math> to be replaced by required dimension.</p> <p>NOTE No dimension to the right of the elementary symbol indicates butt welds shall be continuous.</p>
1.3	Intermittent			<p><math>n</math> = number of weld elements</p> <p><math>l</math> = nominal length of weld elements</p> <p><math>e</math> = distance between weld elements</p> <p><math>n</math>, <math>l</math> and <math>e</math> to be replaced by required values.</p> <p>NOTE No dimension to the left of the elementary symbol indicates the welds shall be full penetration.</p>

Table 5 (continued)



No.	Weld type	Illustration	Symbol <sup>a</sup>	Comments
1.4	Chain intermittent			<p><math>n</math> = number of weld elements  <math>l</math> = nominal length of weld elements  <math>e</math> = distance between weld elements  <math>n</math>, <math>l</math> and <math>e</math> to be replaced by required values.                      NOTE No dimension to the left of the elementary symbol indicates the welds shall be full penetration.</p>
1.5	Staggered intermittent			<p><math>n</math> = number of weld elements  <math>l</math> = nominal length of weld elements  <math>e</math> = distance between weld elements  <math>n</math>, <math>l</math> and <math>e</math> to be replaced by required values.                      NOTE No dimension to the left of the elementary symbol indicates the welds shall be full penetration.</p>
1.6	Flare V			<p><math>s</math> = penetration depth                      letter <math>s</math> to be replaced by required dimension.</p>

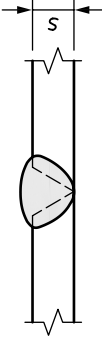

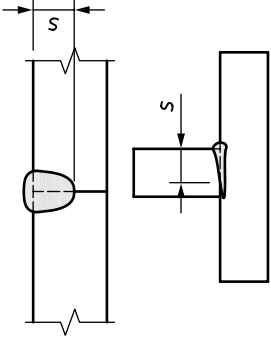
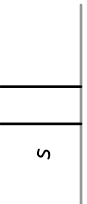
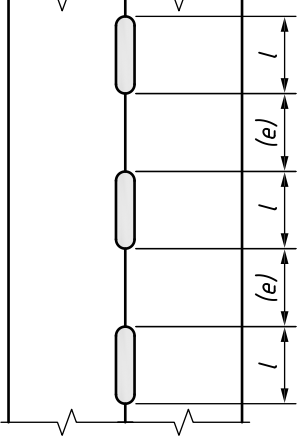
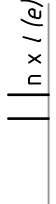
Table 5 (continued)

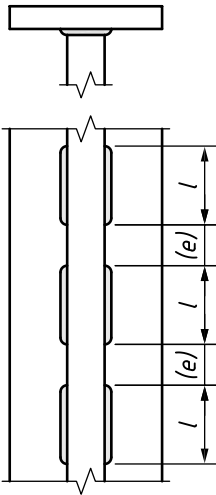
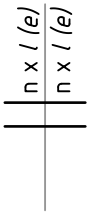
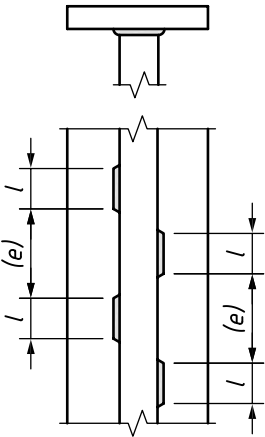
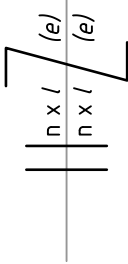
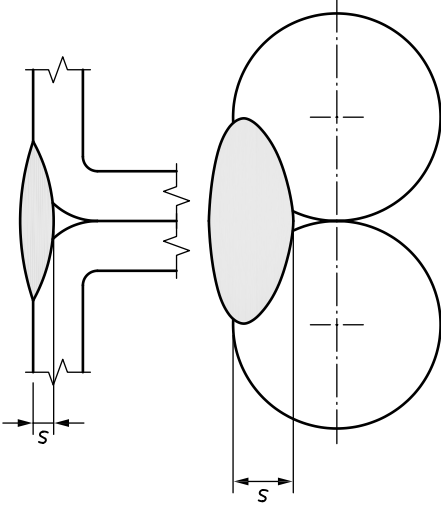

No.	Weld type	Illustration	Symbol <sup>a</sup>	Comments
1.7	Flare bevel			<p><math>s</math> = penetration depth letter <math>s</math> to be replaced by required dimension.</p>
2	<b>FILLET</b>			
2.1	Fillet			<p><math>a</math> = nominal throat thickness <math>z</math> = leg length <math>a</math>, and <math>z</math> are to be included on the welding symbol with the required values.</p>

Table 5 (continued)

No.	Weld type	Illustration	Symbol <sup>a</sup>	Comments
2.2	Deep penetration			<p><math>s</math> = deep penetration throat thickness</p> <p>NOTE <math>s</math> and <math>a</math> are to be included on the welding symbol with the required values.</p>
2.3	Unequal legs			<p><math>z_1 \neq z_2</math></p> <p>If the required leg lengths cannot be identified clearly using the welding symbol, additional sketches or indications are to be given on the drawing or in other documents.</p> <p><math>z_1</math> and <math>z_2</math> are to be included on the welding symbol with the required leg lengths e.g. <math>z_1 z_2</math></p>
2.4	Intermittent			<p><math>n</math> = number of weld elements</p> <p><math>l</math> = nominal length of weld elements</p> <p><math>e</math> = distance between weld elements</p> <p><math>a</math> or <math>z</math> are to be included on the welding symbol with the required value. <math>n</math>, <math>l</math> and <math>e</math> to be replaced by required values.</p>

Table 5 (continued)

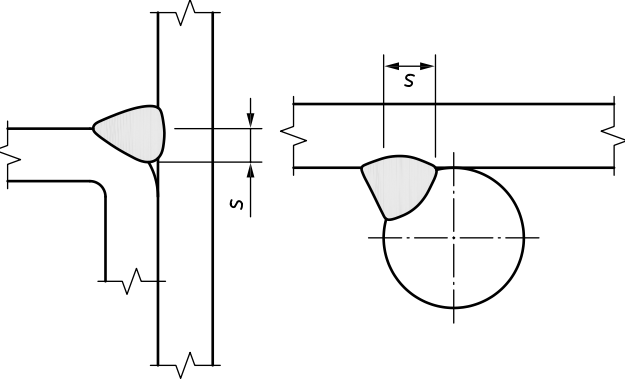
No.	Weld type	Illustration	Symbol <sup>a</sup>	Comments
2.5	Chain intermittent			<p><math>n</math> = number of weld elements  <math>l</math> = nominal length of weld elements  <math>e</math> = distance between weld elements</p>
2.6	Staggered intermittent			<p><math>a</math> or <math>z</math> are to be included on the welding symbol with the required value. <math>n</math>, <math>l</math> and <math>e</math> to be replaced by required values</p>

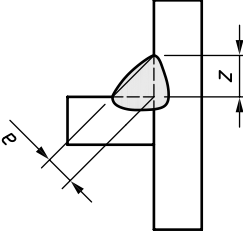
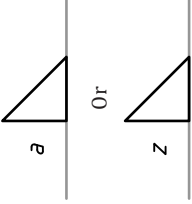
Table 5 (continued)



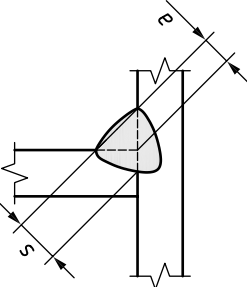
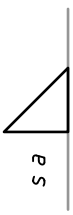
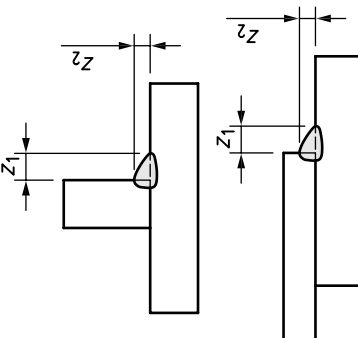
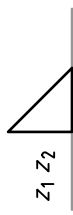
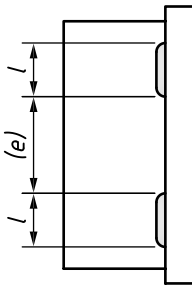
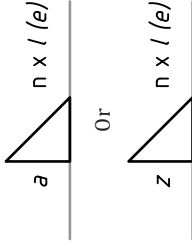

No.	Weld type	Illustration	Symbol <sup>a</sup>	Comments
<b>PLUG WELDS IN CIRCULAR HOLES</b>				
3.1	Complete fill			<p><math>d</math> = required diameter of the plug at the laying surface</p>
3.2	Partial fill			<p><math>s</math> = depth of filling, used if the hole is to be partially filled</p>
3.3	Intermittent			<p><math>e</math> = distance between weld elements (centre to centre)</p> <p><math>n</math> = number of weld elements</p> <p><math>d</math> to be included on the welding symbol with the required value. <math>s</math>, <math>n</math> and <math>e</math>, to be replaced by required values.</p>

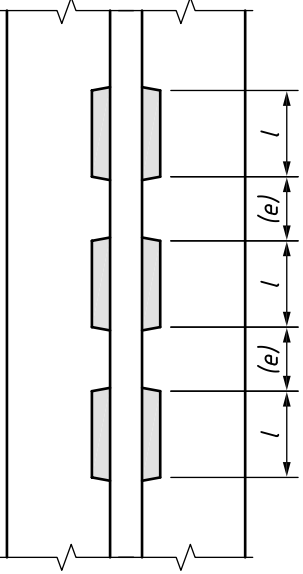
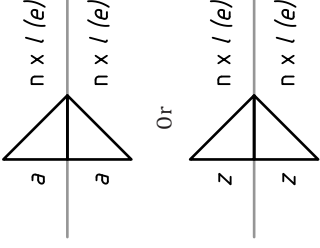
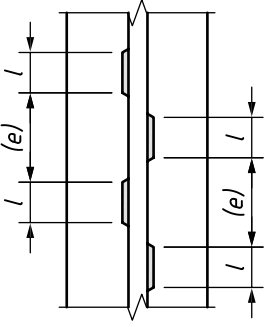
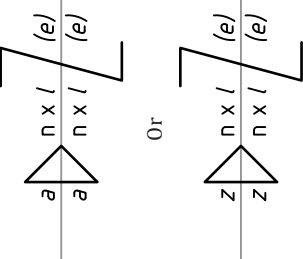
Table 5 (continued)



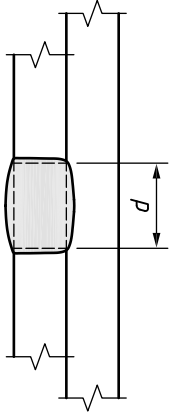

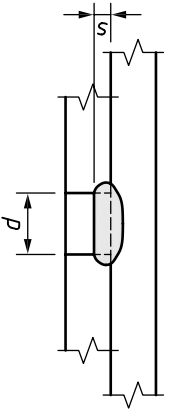
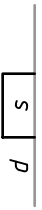
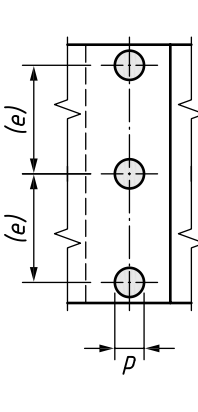
No.	Weld type	Illustration	Symbol <sup>a</sup>	Comments
<b>4 PLUG WELDS IN SLOT</b>				
4.1	Complete fill			<p><math>c</math> = required width of the slot at the faying surface  <math>s</math> = depth of filling, used if the slot is to be partially filled</p>
4.2	Partial fill			<p><math>c</math> to be included on the welding symbol with the required value. <math>s</math>, to be replaced by required value.</p>
4.3	Intermittent			<p><math>c</math> = required width of the slot at the faying surface  <math>n</math> = number of weld elements  <math>l</math> = nominal length of weld elements  <math>e</math> = distance between weld elements  <math>c</math> to be included on the welding symbol with the required value. <math>n</math>, <math>l</math> and <math>e</math>, to be replaced by required values.</p>

Table 5 (continued)

No.	Weld type	Illustration	Symbol <sup>a</sup>	Comments
5	SPOT			
5.1	Resistance			<p><math>d</math> = required spot weld diameter at the faying surface  <math>e</math> = distance between welds (centre to centre)  <math>n</math> = number of welds  <math>d</math> shall be replaced by the required spot weld diameter: <math>n</math> and <math>e</math> are replaced by required dimensions.</p>
5.2	Fusion			<p><math>d</math> = required spot weld diameter at the faying surface  <math>e</math> = distance between welds (centre to centre)  <math>n</math> = number of welds</p>

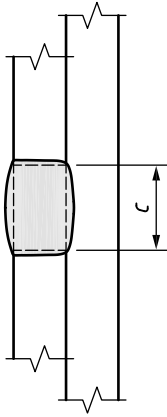
Table 5 (continued)

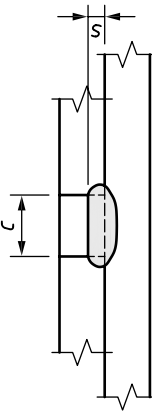
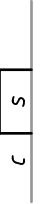
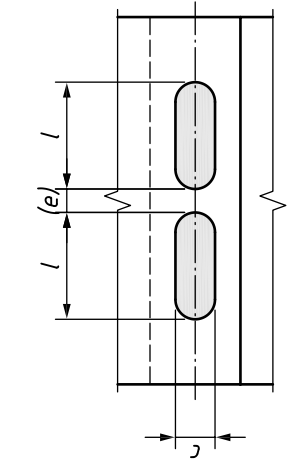
No.	Weld type	Illustration	Symbol <sup>a</sup>	Comments
6	SEAM			
6.1	Resistance			<p><math>c</math> = required seam weld width at the faying surface  <math>n</math> = number of weld elements  <math>l</math> = nominal length of weld elements  <math>e</math> = distance between weld elements                      For continuous resistance seam welds, only the required seam width is specified.</p>
6.2	Fusion			<p><math>c</math> = required seam weld width at the faying surface                      Intermittent welds to be designated using <math>n</math>, <math>l</math> and <math>e</math> as for resistance welds.</p>

Table 5 (continued)







No.	Weld type	Illustration	Symbol <sup>a</sup>	Comments
7	EDGE			
7.1	Lap			<p><math>s</math> = weld metal thickness the minimum distance from the external surface of the weld to the bottom of the penetration</p>
7.2	Flanged butt			
7.3	Flanged corner			
8	STUD			
8.1	Series			<p><math>d</math> = stud size  <math>n</math> = number of studs  <math>e</math> = distance between studs (centre to centre)</p>

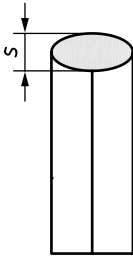

Table 5 (continued)

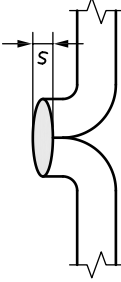
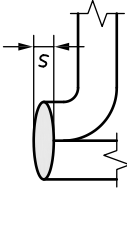
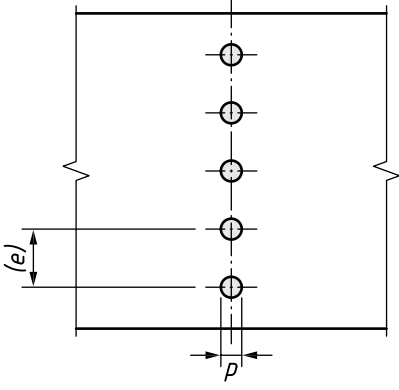
No.	Weld type	Illustration	Symbol <sup>a</sup>	Comments
9	OVERLAY WELDING			
9.1	Overlay			s = overlay thickness
<p><sup>a</sup> The grey line is not part of the symbol. It indicates the position of the reference line.</p>				

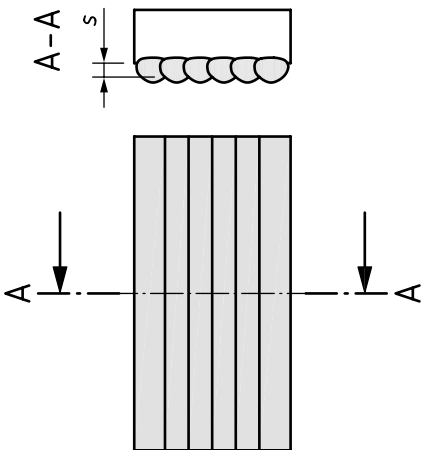
## 6 Dimensioning of joint preparations

### 6.1 General

If required, information concerning the joint dimensions and geometry prior to welding may be included as part of the welding symbol or may be specified elsewhere e.g. by reference to the relevant part of ISO 9692 or on the WPS.

If Information on joint dimensions is to be included it should not overburden the drawings. Reference to other information should be considered first to eliminate the need for this information as part of the symbol.

### 6.2 Root gap

The root gap,  $b$ , of a butt joint may be specified inside the elementary symbol (see [Table 6](#)).

The root gap shall only be shown on one side of the reference line.

**Table 6 — Examples of designating root gap**

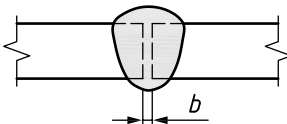
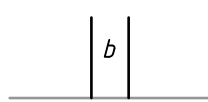
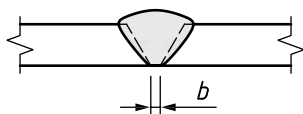
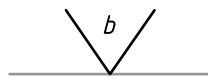
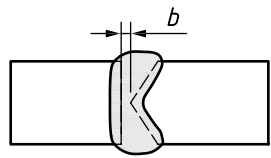
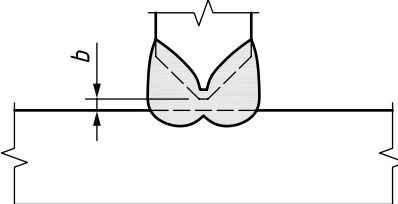
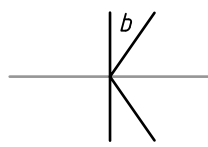
No.	Weld type	Illustration	Symbol
1	Square butt		
2	V butt		
3	Double bevel butt	 	

### 6.3 Included angle

The included angle (groove angle),  $\alpha$ , of a butt joint can be specified outside the elementary symbol (see [Table 7](#)).

For double-sided joints, including symmetrical joints, the preparation angle(s) shall be included on both sides of the welding symbol.

Table 7 — Examples of designating included angle

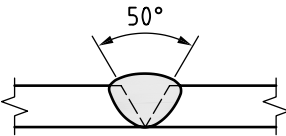
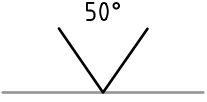
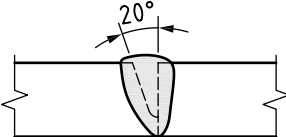
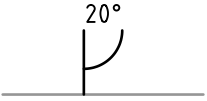
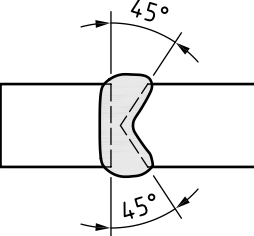
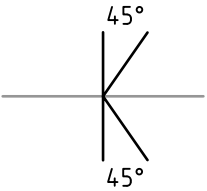
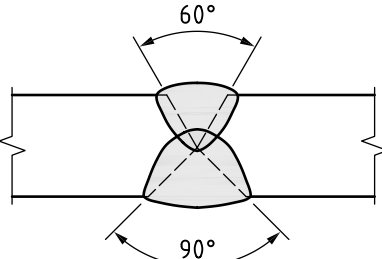
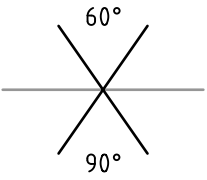
No.	Weld type	Illustration	Symbol
1	V butt		
2	J butt		
3	Double bevel butt (symmetrical)		
4	Double V butt (asymmetrical)		

#### 6.4 Radii and root faces — U and J butt joints

The radii and dimensions of root faces of U and J butt joints are not to be specified as part of welding symbols and shall be specified elsewhere, in a cross section, detail, or other data e.g. the relevant part of ISO 9692 referenced in the tail of the welding symbol.

#### 6.5 Depth of joint preparation

The depth of joint preparation of V-, single-bevel-, U-, J-butt, flare-V and flare bevel welds can be specified to the left of the elementary symbol. The depth of joint preparation in parentheses shall follow the required penetration depth (see [Table 8](#)).

EXAMPLE 8 (6).

NOTE The depth of joint preparation in butt welds can be greater than, equal to, or smaller than the size of the finished weld.

Table 8 — Examples of joint preparation depth designation

No.	Weld type	Illustration	Symbol <sup>a</sup>
1	V butt		
2	Double V butt		

<sup>a</sup>  $s$  and  $h$  are replaced by the actual values.

Table 8 (continued)



No.	Weld type	Illustration	Symbol <sup>a</sup>
3	Flare V		
4	Flare bevel		

<sup>a</sup>  $s$  and  $h$  are replaced by the actual values.

### 6.6 Countersink angle for plug and slot welds

The included angle of countersink of plug and slot welds may be indicated by placing the required dimension above the elementary symbol (see [Table 9](#)).

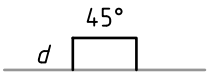
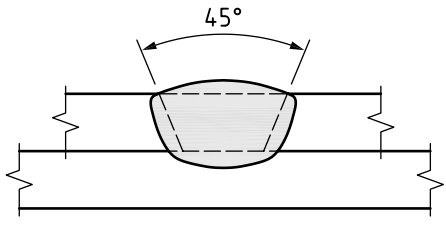
**Table 9 — Countersink angle in plug and slot welds**

No.	Weld type	Symbol <sup>a</sup>	Illustration
1	Plug		
2	Slot		

<sup>a</sup> *c* and *d* are measured at the faying surface (see 5.6 and 5.7) and shall be indicated on the drawing in accordance with Table 5.

## 7 Alternative butt weld symbol with required weld quality

### 7.1 General

The alternative symbol shown in Table 10 can be used to represent butt welds by only specifying the required weld quality. All additional information shall be designated in accordance with this standard.

When using this method, the joint preparation and welding process(es) are determined by the production unit to meet the specified weld quality.

NOTE All other information is specified in the WPS or other documentation based on the available equipment. Different WPSs can be used in other workshops with different equipment but the technical drawing will not need to be revised for each workshop.

**Table 10 — Alternative simplified butt weld symbol**

Symbol	Description
	Butt weld where joint preparation is not defined

### 7.2 Example

An example of a welding symbol based on required weld quality is shown in Figure 8.

Full penetration welds shall not be dimensioned (see Clause 5).

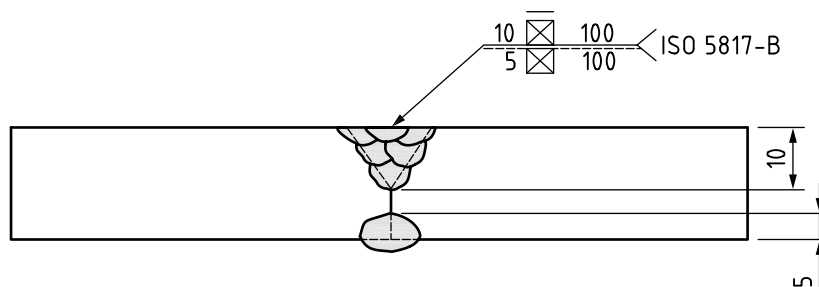

**Figure 8 — Example of a welding symbol based on required weld quality**

## Annex A (informative)

### Examples of the use of welding symbols

The examples given in [Annex A](#) are illustrative only and are intended to demonstrate the proper application of drawing principles. They are not intended to represent good design practices, or to replace code or specification requirements.

[Figure A.1](#) shows examples of comprehensive welding symbols showing the location of weld elements.

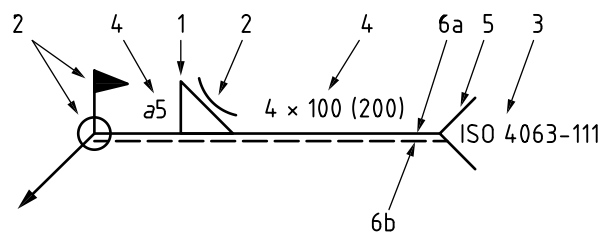

a) Example of a comprehensive welding symbol in accordance with system A

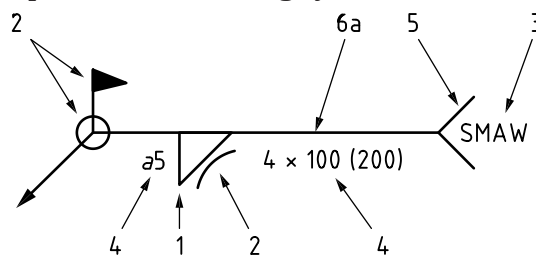

b) Example of comprehensive welding symbol in accordance with system B

#### Key

- 1 elementary symbol (fillet weld)
- 2 supplementary symbol (concave fillet weld contour, field weld, weld all-around)
- 3 complementary information (shielded metal arc welding (SMAW)/process 111 in accordance with ISO 4063)
- 4 dimensions (5 mm nominal throat thickness intermittent fillet weld, composing 4 weld elements 100 mm in length with 200mm spacing between elements)
- 5 tail
- 6a reference line (continuous)
- 6b dashed line (identification line) — system A only

**Figure A.1 — Examples of comprehensive welding symbols** (5 mm nominal throat thickness intermittent fillet weld, composing 4 weld elements 100 mm in length with 200mm spacing between elements)

The welding symbols shown in [Figure A.1](#) designate the same weld on the arrow side of the joint.

NOTE In system A the dashed component of the reference line can be drawn above or below the continuous line (see 4.7.1.1). The examples given in [Tables A.1](#) to [A.3](#) only show the preferred case where the dashed line is drawn below the continuous line.



Table A.1 — Examples of use of broken arrow lines



No.	System A welding symbol	Illustration of weld	System B welding symbol
1			
2			
3			

Table A.2 — Examples of arrow side and other side welds

No.	Weld type	Side	System A welding symbol <sup>a</sup>	Illustration of weld	System B welding symbol	
1	Single bevel butt	Arrow				
	Other					
	Single J butt		Arrow			
	Other					
	Single bevel butt (broad root face)					Arrow
Other						
2			Butt	Arrow		
	Other					

<sup>a</sup> The dashed line is preferred to be drawn below the continuous line.

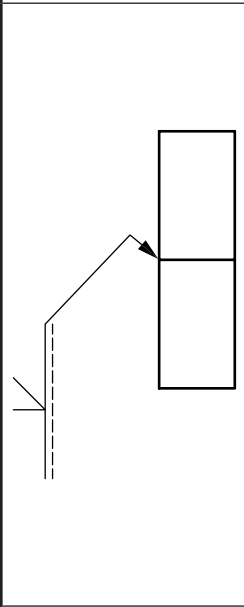
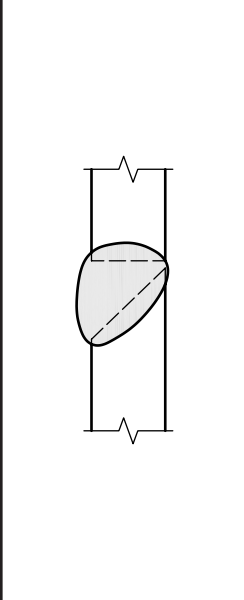
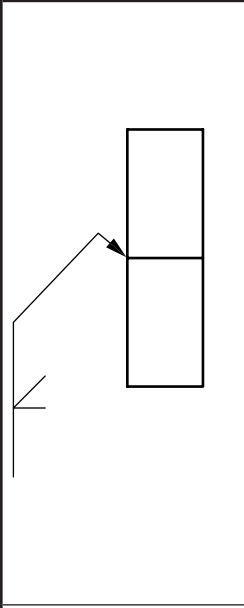
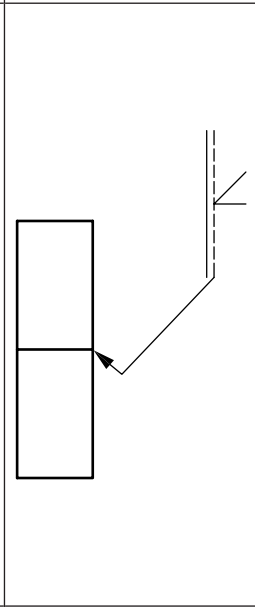
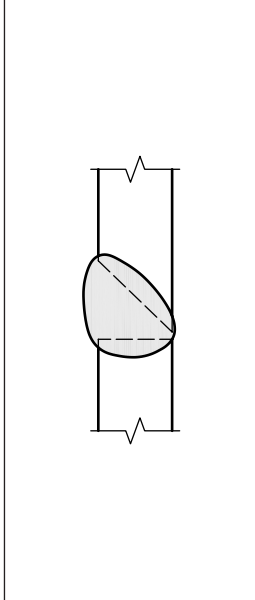
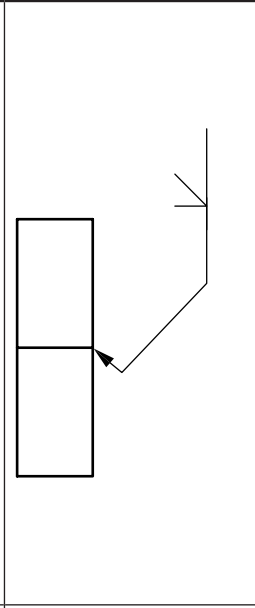
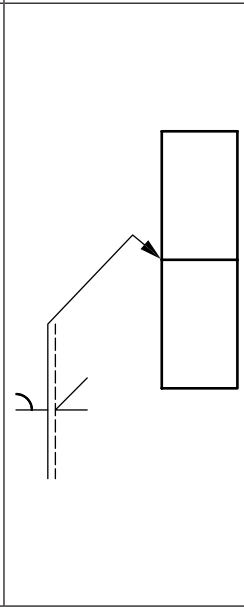
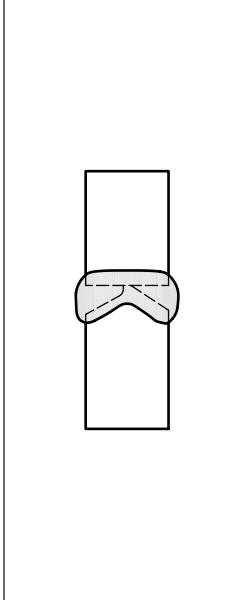
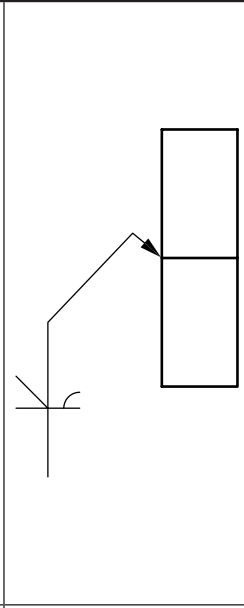
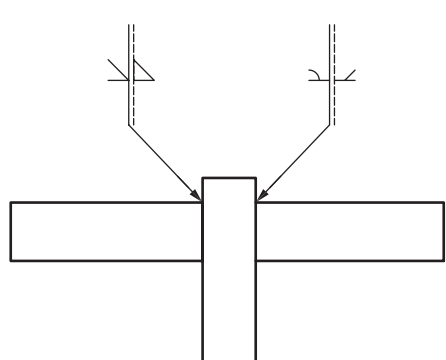
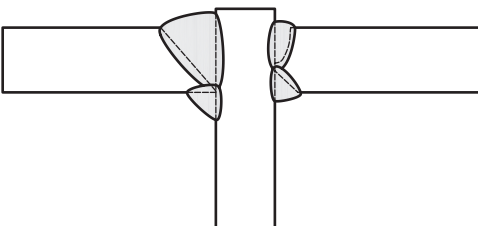
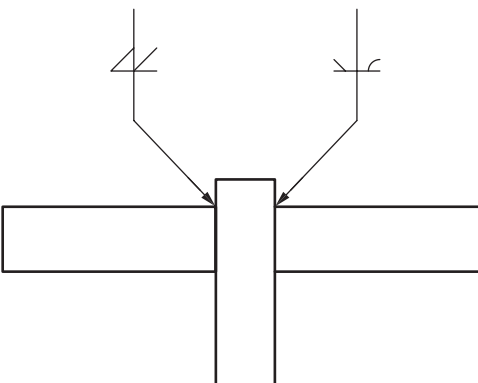
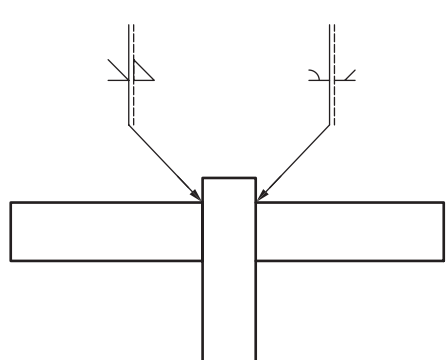
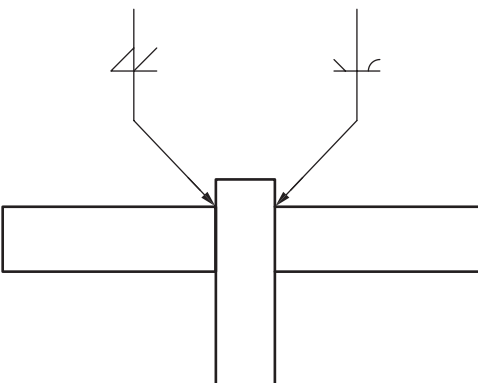
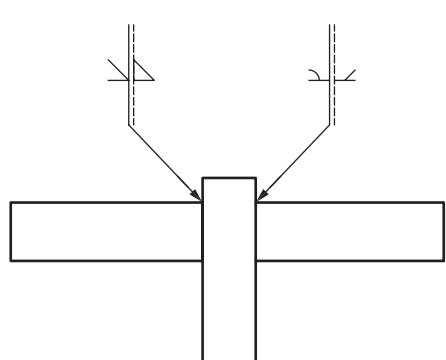
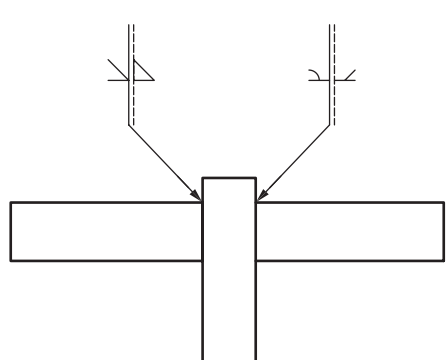
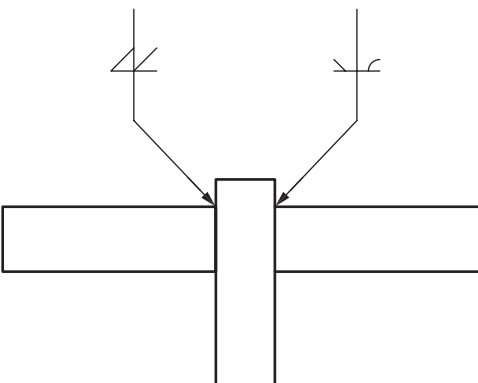
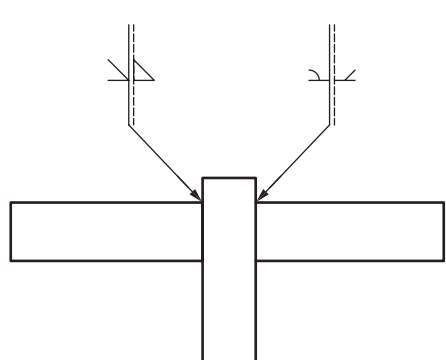
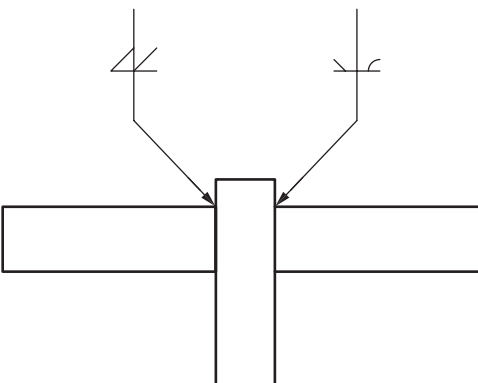
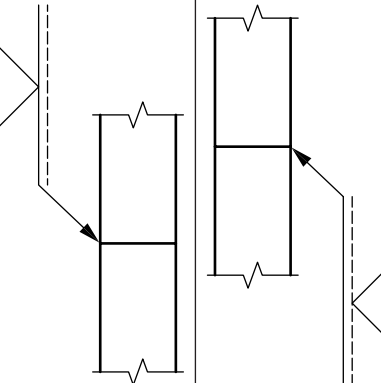
<sup>b</sup> Plug welds require the diameter of the hole to be indicated by use of the Ø symbol.

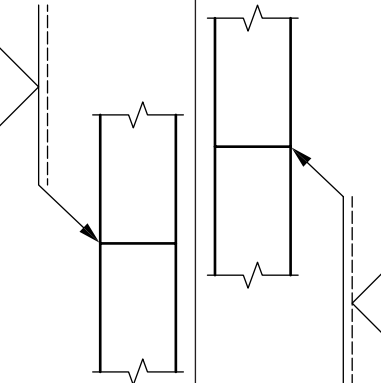
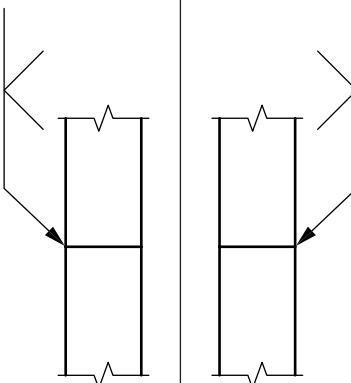
<sup>c</sup> Orientation of the slot is to be shown on the drawing or indicated elsewhere.

Table A.2 (continued)

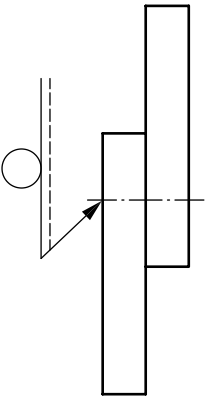
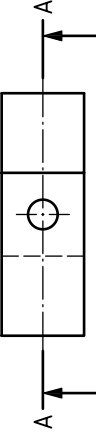
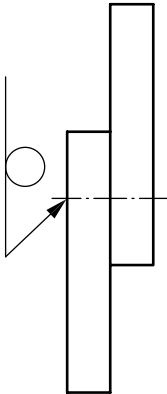
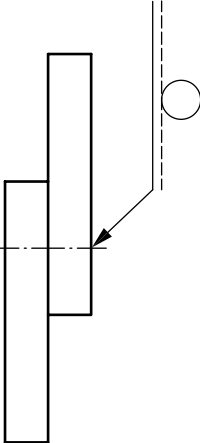
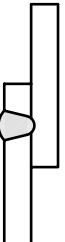
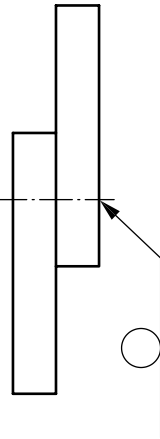
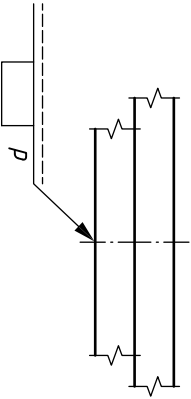
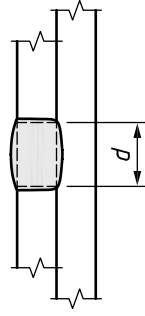
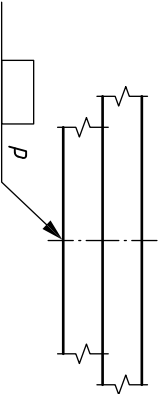
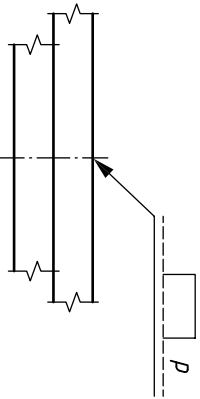
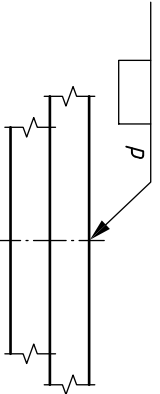
No.	Weld type	Side	System A welding symbol <sup>a</sup>	Illustration of weld	System B welding symbol
3	Fusion spot	Arrow			
3	Fusion spot	Other			
4	Plug <sup>b</sup>	Arrow			
4	Plug <sup>b</sup>	Other			

a The dashed line is preferred to be drawn below the continuous line.  
b Plug welds require the diameter of the hole to be indicated by use of the  $\varnothing$  symbol.  
c Orientation of the slot is to be shown on the drawing or indicated elsewhere.

Table A.2 (continued)

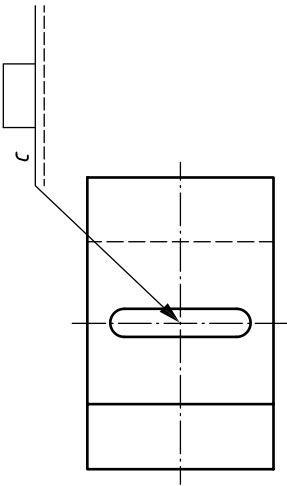
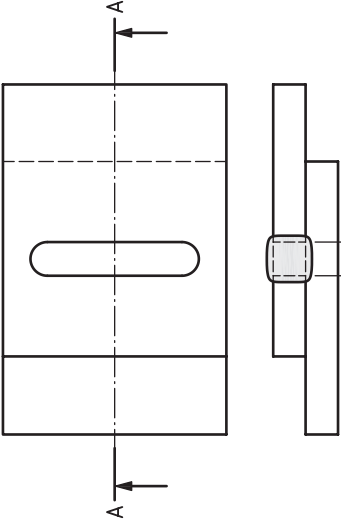
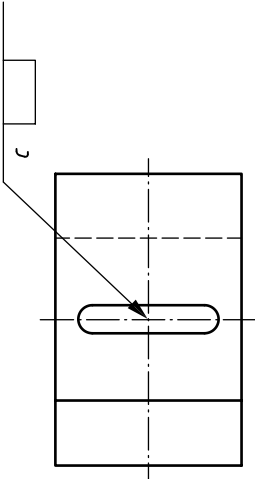
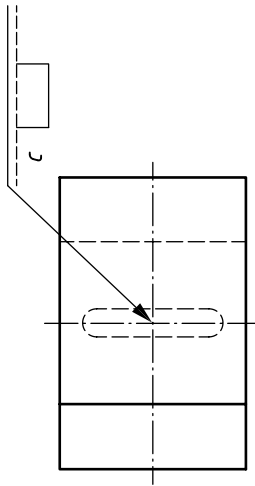
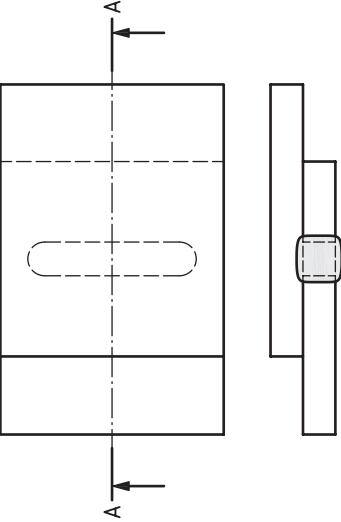
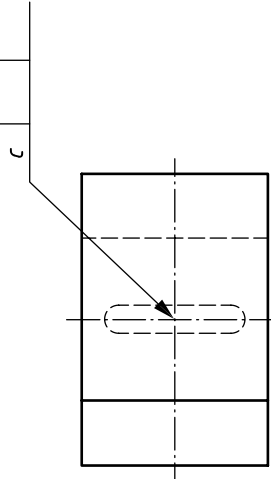
No.	Weld type	Side	System A welding symbol <sup>a</sup>	Illustration of weld	System B welding symbol
5 a)	Slot <sup>c</sup>	Arrow			
5 b)	Slot <sup>c</sup>	Other			

<sup>a</sup> The dashed line is preferred to be drawn below the continuous line.

<sup>b</sup> Plug welds require the diameter of the hole to be indicated by use of the  $\varnothing$  symbol.

<sup>c</sup> Orientation of the slot is to be shown on the drawing or indicated elsewhere.

Table A.2 (continued)





No.	Weld type	Side	System A welding symbol <sup>a</sup>	Illustration of weld	System B welding symbol
6 a)	Fusion seam	Arrow			
6 b)	Fusion seam	Other			

a The dashed line is preferred to be drawn below the continuous line.

b Plug welds require the diameter of the hole to be indicated by use of the  $\varnothing$  symbol.

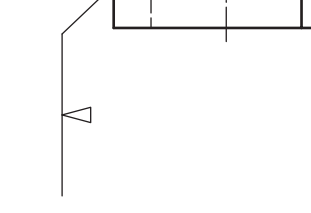
c Orientation of the slot is to be shown on the drawing or indicated elsewhere.

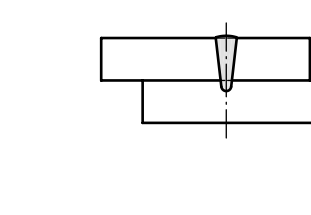
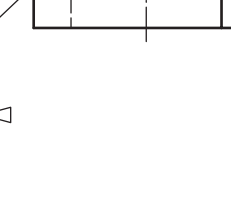
Table A.2 (continued)

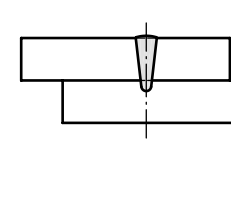
No.	Weld type	Side	System A welding symbol <sup>a</sup>	Illustration of weld	System B welding symbol
6	Stake	c)			
6	Stake	d)			

<sup>a</sup> The dashed line is preferred to be drawn below the continuous line.

<sup>b</sup> Plug welds require the diameter of the hole to be indicated by use of the  $\varnothing$  symbol.

<sup>c</sup> Orientation of the slot is to be shown on the drawing or indicated elsewhere.

Table A.2 (continued)

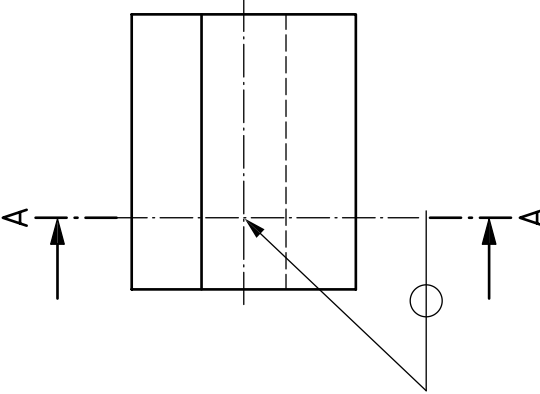
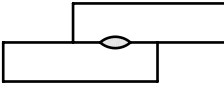
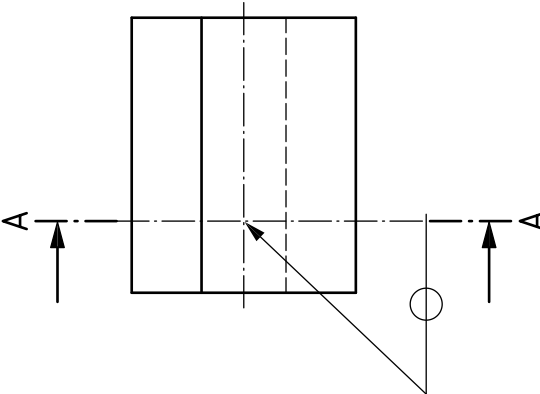
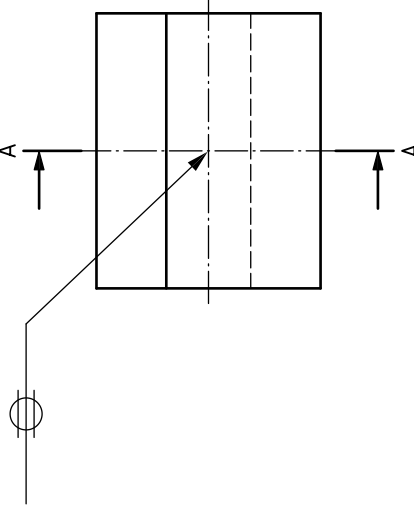
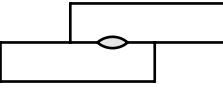
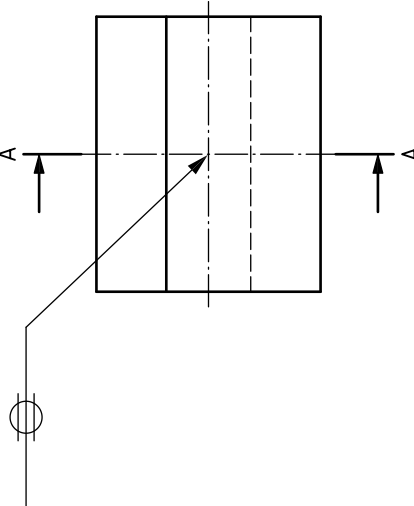
No.	Weld type	Side	System A welding symbol <sup>a</sup>	Illustration of weld	System B welding symbol
7	Resistance spot	No side significance with resistance welds at the interface	 <p>The diagram shows a rectangular symbol with a vertical dashed line in the center. A horizontal dashed line passes through the center of the rectangle. Two arrows labeled 'A' point upwards from the horizontal dashed line, one on each side of the vertical dashed line. A leader line points from the center of the rectangle to a circular symbol with a horizontal line through its center, representing a resistance spot weld.</p>	 <p>The illustration shows two overlapping rectangular plates. A small oval representing the weld is located at the intersection of the two plates.</p>	 <p>The diagram is identical to the System A symbol, but the circular symbol with a horizontal line through its center is positioned below the main symbol, connected by a leader line.</p>
8	Resistance seam	No side significance with resistance welds at the interface	 <p>The diagram shows a rectangular symbol with a vertical dashed line in the center. A horizontal dashed line passes through the center of the rectangle. Two arrows labeled 'A' point upwards from the horizontal dashed line, one on each side of the vertical dashed line. A leader line points from the center of the rectangle to a circular symbol with a horizontal line through its center, representing a resistance seam.</p>	 <p>The illustration shows two overlapping rectangular plates. A small oval representing the weld is located at the intersection of the two plates.</p>	 <p>The diagram is identical to the System A symbol, but the circular symbol with a horizontal line through its center is positioned below the main symbol, connected by a leader line.</p>

<sup>a</sup> The dashed line is preferred to be drawn below the continuous line.

<sup>b</sup> Plug welds require the diameter of the hole to be indicated by use of the  $\varnothing$  symbol.

<sup>c</sup> Orientation of the slot is to be shown on the drawing or indicated elsewhere.

Table A.2 (continued)

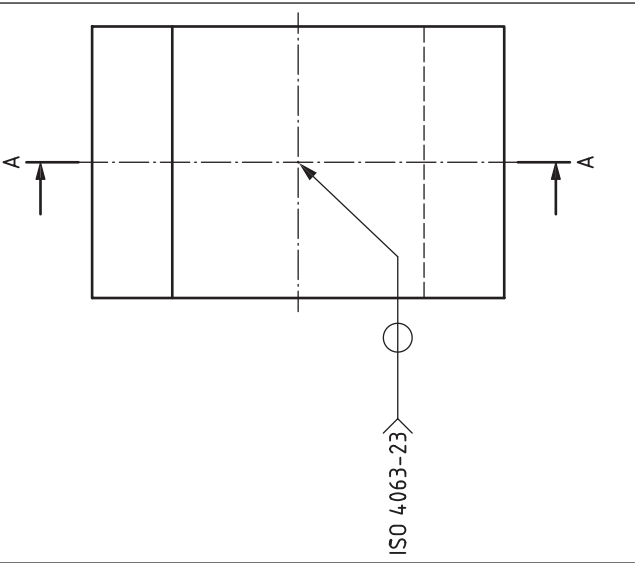
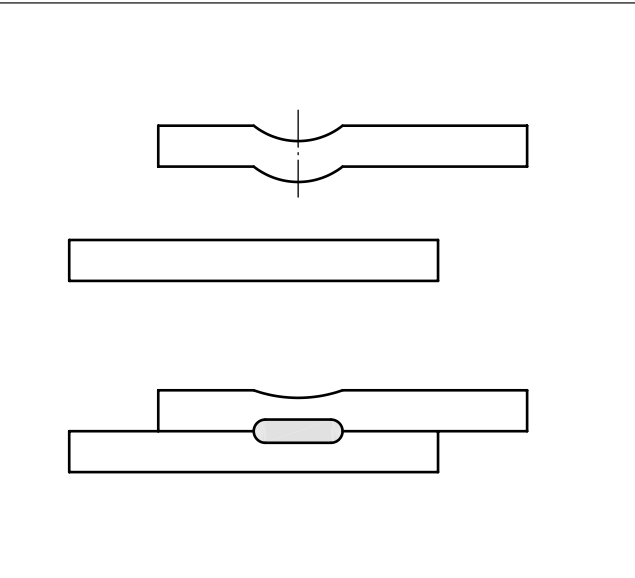
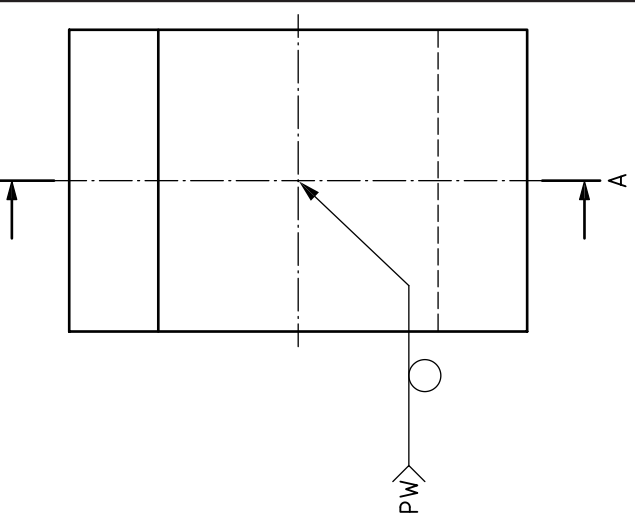
No.	Weld type	Side	System A welding symbol <sup>a</sup>	Illustration of weld	System B welding symbol
9	Projec- tion	Arrow points to the sheet con- tain- ing the projec- tion			

<sup>a</sup> The dashed line is preferred to be drawn below the continuous line.

<sup>b</sup> Plug welds require the diameter of the hole to be indicated by use of the Ø symbol.

<sup>c</sup> Orientation of the slot is to be shown on the drawing or indicated elsewhere.



Table A.3 — Examples of welding symbols for asymmetrical welds

No.	Weld type	System A welding symbol <sup>a</sup>	Illustration of weld	System B welding symbol
1	Butt			
2	Fillet <sup>b</sup>			

<sup>a</sup> Asymmetrical welds are always dimensioned regardless if they are partial or full penetration welds (see [Clause 6](#)).

<sup>b</sup> If throat thickness is specified, symbol  $a$  is used in place of  $z$ .

**Annex B**  
 (informative)

**Tolerances and transition points for weld types<sup>[9]</sup>**

Joint type	Weld type	Transition/tolerance	$\alpha$	Symbol
Butt	Butt		135° to 180° inclusive	<a href="#">Table 1</a> , No. 1
Corner	Fillet		Over 30° and less than 135°	<a href="#">Table 1</a> , No. 10
Edge	Edge		0° to 30° inclusive	<a href="#">Table 1</a> , No. 19
Angle	Butt		45° to 90° inclusive	<a href="#">Table 1</a> , No. 4
Angle	Fillet		Over 5° and less than 45°	<a href="#">Table 1</a> , No. 10
Lap	Fillet		0° to 5° inclusive	<a href="#">Table 1</a> , No. 10

## Annex C (informative)

### Alternative methods for designating intermittent butt and fillet welds

#### C.1 General

The alternative methods for designating intermittent butt and fillet welds are included for informational purposes only. These methods are used or adapted in at least AWS A2.4:2007, AS 1101.3-2005 and JIS C Z 3021:2010. Information on how to designate other intermittent weld types can be found in these standards.

#### C.2 Butt welds

##### C.2.1 Intermittent butt welds

The pitch of intermittent butt welds is defined as the distance between the centres of adjacent weld elements on one side of the joint. The pitch of intermittent butt welds is specified to the right of the length dimension following a hyphen (see [Table C.1](#)).

##### C.2.2 Chain intermittent butt welds

The dimensions of chain intermittent butt welds are specified on both sides of the reference line. The elements of chain intermittent butt welds are made approximately opposite one another across the joint (see [Table C.1](#)).

##### C.2.3 Staggered Intermittent butt Welds

The dimensions of staggered intermittent butt welds are specified on both sides of the reference line, and the butt weld symbols are offset on opposite sides of the reference line (see [Table C.1](#)).

#### C.3 Fillet welds

##### C.3.1 Intermittent fillet welds

The pitch of intermittent fillet welds is defined as the distance between the centres of adjacent weld elements on one side of the joint. The pitch of intermittent fillet welds is specified to the right of the length dimension following a hyphen (see [Table C.2](#)).

##### C.3.2 Chain intermittent fillet welds

The dimensions of chain intermittent fillet welds are specified on both sides of the reference line. The elements of chain intermittent fillet welds are made approximately opposite one another across the joint (see [Table C.2](#)).

##### C.3.3 Staggered Intermittent fillet welds

The dimensions of staggered intermittent fillet welds are specified on both sides of the reference line, and the fillet weld symbols shall be offset on opposite sides of the reference line (see [Table C.2](#)).

**Table C.1 — Butt welds**

No.	Weld type	Illustration of weld	AWS A2.4 welding symbol
1	Intermittent		
2	Chain Intermittent		
3	Staggered Intermittent		

**Table C.2 — Fillet welds**

No.	Weld type	Illustration of weld	AWS A2.4 welding symbol
1	Intermittent		

Table C.2 (continued)

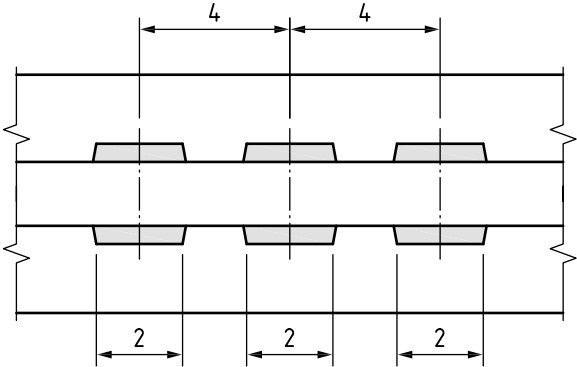
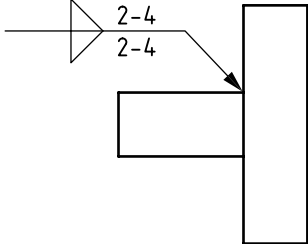
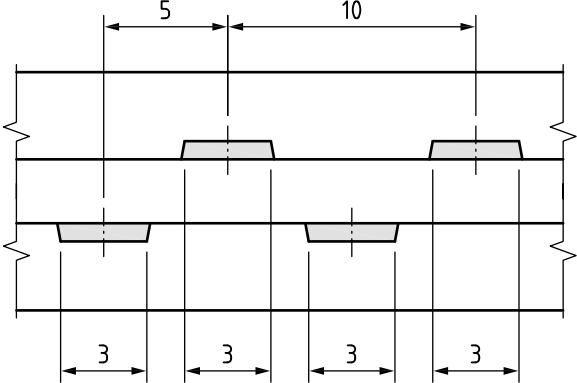
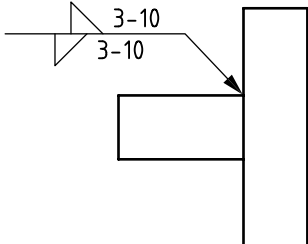
No.	Weld type	Illustration of weld	AWS A2.4 welding symbol
2	Chain intermittent	 <p>The illustration shows a cross-section of a chain intermittent weld between two plates. The weld consists of three rectangular weld ripples. The distance between the centers of two adjacent ripples is 4 units. The width of each individual ripple is 2 units. The weld is shown in a perspective view with break lines at the ends.</p>	 <p>The AWS A2.4 welding symbol consists of a triangle pointing to the right, with the number '2-4' written above it and another '2-4' written below it. An arrow points from the symbol to a vertical rectangular plate, which is attached to a horizontal rectangular plate.</p>
3	Staggered intermittent	 <p>The illustration shows a cross-section of a staggered intermittent weld between two plates. The weld consists of three rectangular weld ripples. The distance between the centers of two adjacent ripples is 5 units. The distance between the center of one ripple and the center of the next ripple in the second row is 10 units. The width of each individual ripple is 3 units. The weld is shown in a perspective view with break lines at the ends.</p>	 <p>The AWS A2.4 welding symbol consists of a triangle pointing to the right, with the number '3-10' written above it and another '3-10' written below it. An arrow points from the symbol to a vertical rectangular plate, which is attached to a horizontal rectangular plate.</p>

## Bibliography

- [1] ISO 2553:1992, *Welded, brazed and soldered joints — Symbolic representation on drawings*
- [2] ISO 5817, *Welding — Fusion-welded joints in steel, nickel, titanium and their alloys (beam welding excluded) — Quality levels for imperfections*
- [3] ISO 10042, *Welding — Arc-welded joints in aluminium and its alloys — Quality levels for imperfections*
- [4] ISO 13919, *Welding – Electron and laser-beam welded joints – Guidance on quality levels for imperfections*
- [5] ISO 14171, *Welding consumables — Wire electrodes and wire-flux combinations for submerged arc welding of non alloy and fine grain steels — Classification*
- [6] ISO 14341, *Welding consumables — Wire electrodes and weld deposits for gas shielded metal arc welding of non alloy and fine grain steels — Classification*
- [7] ISO 6947, *Welding and allied processes — Welding positions*
- [8] ISO 9692 (all parts), *Welding and allied processes — Types of joint preparation*
- [9] ISO 17659:2002, *Welding — Multilingual terms for welded joints with illustrations*
- [10] GREGORY E. N., & ARMSTRONG A. A. *Welding symbols on drawings*, Abington, Cambridge: Woodhead Publishing Limited. ISBN 1-85573-589-X
- [11] AWS A2.4:2007, *Standard Symbols for Welding, Brazing, and Nondestructive Examination*
- [12] ISO 14731:2006, *Welding coordination — Tasks and responsibilities*
- [13] AS 1101.3:2005, *Graphical symbols for welding engineering — Part 3: welding and non-destructive examination*
- [14] JIS C Z 3021:2010, *Welding and allied processes — Symbolic representation*









# British Standards Institution (BSI)

BSI is the national body responsible for preparing British Standards and other standards-related publications, information and services.

BSI is incorporated by Royal Charter. British Standards and other standardization products are published by BSI Standards Limited.

## About us

We bring together business, industry, government, consumers, innovators and others to shape their combined experience and expertise into standards-based solutions.

The knowledge embodied in our standards has been carefully assembled in a dependable format and refined through our open consultation process. Organizations of all sizes and across all sectors choose standards to help them achieve their goals.

## Information on standards

We can provide you with the knowledge that your organization needs to succeed. Find out more about British Standards by visiting our website at [bsigroup.com/standards](http://bsigroup.com/standards) or contacting our Customer Services team or Knowledge Centre.

## Buying standards

You can buy and download PDF versions of BSI publications, including British and adopted European and international standards, through our website at [bsigroup.com/shop](http://bsigroup.com/shop), where hard copies can also be purchased.

If you need international and foreign standards from other Standards Development Organizations, hard copies can be ordered from our Customer Services team.

## Subscriptions

Our range of subscription services are designed to make using standards easier for you. For further information on our subscription products go to [bsigroup.com/subscriptions](http://bsigroup.com/subscriptions).

With **British Standards Online (BSOL)** you'll have instant access to over 55,000 British and adopted European and international standards from your desktop. It's available 24/7 and is refreshed daily so you'll always be up to date.

You can keep in touch with standards developments and receive substantial discounts on the purchase price of standards, both in single copy and subscription format, by becoming a **BSI Subscribing Member**.

**PLUS** is an updating service exclusive to BSI Subscribing Members. You will automatically receive the latest hard copy of your standards when they're revised or replaced.

To find out more about becoming a BSI Subscribing Member and the benefits of membership, please visit [bsigroup.com/shop](http://bsigroup.com/shop).

With a **Multi-User Network Licence (MUNL)** you are able to host standards publications on your intranet. Licences can cover as few or as many users as you wish. With updates supplied as soon as they're available, you can be sure your documentation is current. For further information, email [bsmusales@bsigroup.com](mailto:bsmusales@bsigroup.com).

## BSI Group Headquarters

389 Chiswick High Road London W4 4AL UK

## Revisions

Our British Standards and other publications are updated by amendment or revision.

We continually improve the quality of our products and services to benefit your business. If you find an inaccuracy or ambiguity within a British Standard or other BSI publication please inform the Knowledge Centre.

## Copyright

All the data, software and documentation set out in all British Standards and other BSI publications are the property of and copyrighted by BSI, or some person or entity that owns copyright in the information used (such as the international standardization bodies) and has formally licensed such information to BSI for commercial publication and use. Except as permitted under the Copyright, Designs and Patents Act 1988 no extract may be reproduced, stored in a retrieval system or transmitted in any form or by any means – electronic, photocopying, recording or otherwise – without prior written permission from BSI. Details and advice can be obtained from the Copyright & Licensing Department.

## Useful Contacts:

### Customer Services

**Tel:** +44 845 086 9001

**Email (orders):** [orders@bsigroup.com](mailto:orders@bsigroup.com)

**Email (enquiries):** [cservices@bsigroup.com](mailto:cservices@bsigroup.com)

### Subscriptions

**Tel:** +44 845 086 9001

**Email:** [subscriptions@bsigroup.com](mailto:subscriptions@bsigroup.com)

### Knowledge Centre

**Tel:** +44 20 8996 7004

**Email:** [knowledgecentre@bsigroup.com](mailto:knowledgecentre@bsigroup.com)

### Copyright & Licensing

**Tel:** +44 20 8996 7070

**Email:** [copyright@bsigroup.com](mailto:copyright@bsigroup.com)



...making excellence a habit.™