

**Non-conductive  
coatings on  
non-magnetic  
electrically conductive  
basis materials —  
Measurement of  
coating thickness —  
Amplitude-sensitive  
eddy current method**

The European Standard EN ISO 2360:2003 has the status of a  
British Standard

ICS 25.220.20

Confirmed  
May 2009

## National foreword

This British Standard is the official English language version of EN ISO 2360:2003. It is identical with ISO 2360:2003. It supersedes BS EN ISO 2360:1995 which is withdrawn.

The UK participation in its preparation was entrusted to Technical Committee STI/37, Methods of test for metallic and related inorganic coatings including corrosion tests, which has the responsibility to:

- aid enquirers to understand the text;
- present to the responsible international/European committee any enquiries on the interpretation, or proposals for change, and keep the UK interests informed;
- monitor related international and European developments and promulgate them in the UK.

A list of organizations represented on this committee can be obtained on request to its secretary.

### Cross-references

The British Standards which implement international or European publications referred to in this document may be found in the *BSI Catalogue* under the section entitled “International Standards Correspondence Index”, or by using the “Search” facility of the *BSI Electronic Catalogue* or of British Standards Online.

This publication does not purport to include all the necessary provisions of a contract. Users are responsible for its correct application.

**Compliance with a British Standard does not of itself confer immunity from legal obligations.**

### Summary of pages

This document comprises a front cover, an inside front cover, the EN ISO title page, the EN ISO foreword page, the ISO title page, pages ii to iv, pages 1 to 11 and a back cover.

The BSI copyright notice displayed in this document indicates when the document was last issued.

### Amendments issued since publication

Amd. No.	Date	Comments
14983 Corrigendum No. 1	22 January 2004	Corrected EN ISO foreword

This British Standard was published under the authority of the Standards Policy and Strategy Committee on 9 December 2003

© BSI 22 January 2004

EUROPEAN STANDARD

EN ISO 2360

NORME EUROPÉENNE

EUROPÄISCHE NORM

November 2003

ICS 25.220.20

Supersedes EN ISO 2360:1995

English version

Non-conductive coatings on non-magnetic electrically  
conductive basis materials - Measurement of coating thickness -  
Amplitude-sensitive eddy current method (ISO 2360:2003)

Revêtements non conducteurs sur matériaux de base non  
magnétiques conducteurs de l'électricité - Mesurage de  
l'épaisseur de revêtement - Méthode par courants de  
Foucault sensible aux variations d'amplitude (ISO  
2360:2003)

Nichtleitende Überzüge auf nichtmagnetischen  
metallischen Grundwerkstoffen - Messen der Schichtdicke  
- Wirbelstromverfahren (ISO 2360:2003)

This European Standard was approved by CEN on 27 October 2003.

CEN members are bound to comply with the CEN/CENELEC Internal Regulations which stipulate the conditions for giving this European Standard the status of a national standard without any alteration. Up-to-date lists and bibliographical references concerning such national standards may be obtained on application to the Management Centre or to any CEN member.

This European Standard exists in three official versions (English, French, German). A version in any other language made by translation under the responsibility of a CEN member into its own language and notified to the Management Centre has the same status as the official versions.

CEN members are the national standards bodies of Austria, Belgium, Czech Republic, Denmark, Finland, France, Germany, Greece, Hungary, Iceland, Ireland, Italy, Luxembourg, Malta, Netherlands, Norway, Portugal, Slovakia, Spain, Sweden, Switzerland and United Kingdom.



EUROPEAN COMMITTEE FOR STANDARDIZATION  
COMITÉ EUROPÉEN DE NORMALISATION  
EUROPÄISCHES KOMITEE FÜR NORMUNG

Management Centre: rue de Stassart, 36 B-1050 Brussels

CORRECTED 2003-12-17

## Foreword

This document (EN ISO 2360:2003) has been prepared by Technical Committee ISO/TC 107 "Metallic and other inorganic coatings" in collaboration with Technical Committee CEN/TC 262 "Metallic and other inorganic coatings", the secretariat of which is held by BSI.

This European Standard shall be given the status of a national standard, either by publication of an identical text or by endorsement, at the latest by May 2004, and conflicting national standards shall be withdrawn at the latest by May 2004.

This document supersedes EN ISO 2360:1995.

According to the CEN/CENELEC Internal Regulations, the national standards organizations of the following countries are bound to implement this European Standard: Austria, Belgium, Czech Republic, Denmark, Finland, France, Germany, Greece, Hungary, Iceland, Ireland, Italy, Luxembourg, Malta, Netherlands, Norway, Portugal, Slovakia, Spain, Sweden, Switzerland and the United Kingdom.

## Endorsement notice

The text of ISO 2360:2003 has been approved by CEN as EN ISO 2360:2003 without any modifications.

INTERNATIONAL  
STANDARD

ISO  
2360

Third edition  
2003-11-15

---

---

**Non-conductive coatings on  
non-magnetic electrically conductive  
basis materials — Measurement of  
coating thickness — Amplitude-sensitive  
eddy current method**

*Revêtements non conducteurs sur matériaux de base non magnétiques  
conducteurs de l'électricité — Mesurage de l'épaisseur de  
revêtement — Méthode par courants de Foucault sensible aux  
variations d'amplitude*



Reference number  
ISO 2360:2003(E)



# Contents

Page

Foreword.....	iv
<b>1</b> <b>Scope</b> .....	<b>1</b>
<b>2</b> <b>Principle</b> .....	<b>1</b>
<b>3</b> <b>Apparatus</b> .....	<b>1</b>
<b>4</b> <b>Sampling</b> .....	<b>1</b>
<b>5</b> <b>Factors affecting measurement uncertainty</b> .....	<b>2</b>
5.1 <b>Coating thickness</b> .....	<b>2</b>
5.2 <b>Electrical properties of the basis materials</b> .....	<b>2</b>
5.3 <b>Basis metal thickness</b> .....	<b>2</b>
5.4 <b>Edge effects</b> .....	<b>2</b>
5.5 <b>Surface curvature</b> .....	<b>2</b>
5.6 <b>Surface roughness</b> .....	<b>3</b>
5.7 <b>Lift-off effect</b> .....	<b>3</b>
5.8 <b>Probe pressure</b> .....	<b>3</b>
5.9 <b>Probe tilt</b> .....	<b>3</b>
5.10 <b>Temperature effects</b> .....	<b>3</b>
5.11 <b>Intermediate coatings</b> .....	<b>3</b>
<b>6</b> <b>Procedure</b> .....	<b>4</b>
6.1 <b>Calibration of instruments</b> .....	<b>4</b>
6.2 <b>Determination</b> .....	<b>5</b>
<b>7</b> <b>Expression of results</b> .....	<b>5</b>
<b>8</b> <b>Measurement uncertainty</b> .....	<b>6</b>
<b>9</b> <b>Test report</b> .....	<b>6</b>
<b>Annex A</b> (informative) <b>Eddy current generation in a metallic conductor</b> .....	<b>7</b>
<b>Annex B</b> (normative) <b>Test for edge effect</b> .....	<b>10</b>
<b>Bibliography</b> .....	<b>11</b>

## Foreword

ISO (the International Organization for Standardization) is a worldwide federation of national standards bodies (ISO member bodies). The work of preparing International Standards is normally carried out through ISO technical committees. Each member body interested in a subject for which a technical committee has been established has the right to be represented on that committee. International organizations, governmental and non-governmental, in liaison with ISO, also take part in the work. ISO collaborates closely with the International Electrotechnical Commission (IEC) on all matters of electrotechnical standardization.

International Standards are drafted in accordance with the rules given in the ISO/IEC Directives, Part 2.

The main task of technical committees is to prepare International Standards. Draft International Standards adopted by the technical committees are circulated to the member bodies for voting. Publication as an International Standard requires approval by at least 75 % of the member bodies casting a vote.

Attention is drawn to the possibility that some of the elements of this document may be the subject of patent rights. ISO shall not be held responsible for identifying any or all such patent rights.

ISO 2360 was prepared by Technical Committee ISO/TC 107, *Metallic and other inorganic coatings*, Subcommittee SC 2, *Test methods*.

This third edition cancels and replaces the second edition (ISO 2360:1982), which has been technically revised.



# Non-conductive coatings on non-magnetic electrically conductive basis materials — Measurement of coating thickness — Amplitude-sensitive eddy current method

## 1 Scope

This International Standard describes a method for non-destructive measurements of the thickness of non-conductive coatings on non-magnetic, electrically conductive (generally metallic) basis materials, using amplitude-sensitive eddy current instruments.

NOTE This method can also be used to measure non-magnetic metallic coatings on non-conductive basis materials.

The method is particularly applicable to measurements of the thickness of most oxide coatings produced by anodizing, but is not applicable to all conversion coatings, some of which are too thin to be measured by this method (see Clause 6).

Although theoretically, the method can be used for measurements of the thickness of coatings on magnetic basis materials, its use for this application is not recommended. In such cases, the magnetic method specified in ISO 2178 should be used.

## 2 Principle

An eddy current probe (or integrated probe/instrument) is placed on the surface of the coating(s) to be measured, and the thickness is read from the instrument's readout.

## 3 Apparatus

**3.1 Probe**, containing an eddy current generator and detector linked to a system capable of measuring and displaying the changes in amplitude, normally as a direct readout of coating thickness. The system may also be able to measure phase changes.

NOTE 1 The probe and measuring system/display may be integrated into a single instrument.

NOTE 2 Factors affecting measurement accuracy are discussed in Clause 5.

## 4 Sampling

Sampling depends on the specific application and coating to be tested. The area, location and number of test specimens shall be agreed between interested parties and shall be included in the test report (see Clause 9).

## 5 Factors affecting measurement uncertainty

### 5.1 Coating thickness

A measurement uncertainty is inherent in the method. For thin coatings, this measurement uncertainty (in absolute terms) is constant, independent of the coating thickness and, for a single measurement, is at least 0,5 µm. For coatings thicker than 25 µm, the uncertainty becomes relative to the thickness and is approximately a constant fraction of that thickness.

For measuring coating thicknesses of 5 µm or less, the average of several measurements shall be taken.

It may not be possible to obtain the measurement uncertainty specified in Clause 8 when measuring coatings of less than 3 µm in thickness.

### 5.2 Electrical properties of the basis materials

Measurements using eddy current instruments can be affected by the electrical conductivity of the basis metal, which is a function of the composition and heat treatment of the material. The influence of electrical conductivity on the measurement varies considerably with the make and type of instrument.

### 5.3 Basis metal thickness

For each instrument there is a critical minimum basis metal thickness above which measurements are not affected by an increase in thickness. Since this thickness depends on both the eddy current generation frequency of the probe system and the electrical properties of the basis material its value should be determined experimentally, unless otherwise specified by the manufacturer.

An explanation of Eddy current generation and the calculation of the required minimum basis material thickness,  $d_{\min}$ , is given in Annex A.

However, in the absence of any other information, the required minimum basis material thickness,  $d_{\min}$ , can be estimated from the equation:

$$d_{\min} = 2,5 \delta_0$$

where  $\delta_0$  is the standard penetration depth of the basis material (see A.1).

### 5.4 Edge effects

Eddy current instruments can be sensitive to abrupt changes in surface contour of test specimen. Therefore measurements made too near to an edge or corner may not be valid unless the instrument has been specifically calibrated for such measurements (see 6.2.4 and Annex B).

NOTE When compared with the phase-sensitive method of ISO 21968, the amplitude-sensitive eddy current instruments can be substantially more heavily affected by edge effects.

### 5.5 Surface curvature

Measurements are affected by the curvature of the test specimen. This influence of curvature varies considerably with the make and type of instrument and probe, but always becomes more pronounced as the radius of curvature decreases. Measurements made on curved test specimens might not, therefore, be valid unless the instrument is specifically calibrated for the surface curvature in question, or a special probe, which compensates for surface influence, is used.

## 5.6 Surface roughness

Measurements are influenced by the surface topography of the basis material and of the coating. Rough surfaces can cause both systematic and random errors. Random errors can be reduced by making multiple measurements, each measurement being made at a different location, and then calculating the average value of that series of measurements.

If the basis material is rough, the zero of the instrument shall be checked at several locations on a typical sample of the uncoated, rough, basis material. If no typical uncoated basis material is available, the coating of the test specimen shall be stripped, at least over part of its area, with a chemical solution that does not attack the basis material.

NOTE When compared with the phase-sensitive method of ISO 21968, the amplitude-sensitive eddy current measurement can be more heavily affected by basis material roughness.

## 5.7 Lift-off effect

If the probe is not placed directly on the coating, the gap between probe and coating ("lift-off") affects the measurement of the coating thickness. The measured thickness will be equal to the coating thickness plus the additional "lift-off" gap.

Lift-off can be produced unintentionally, e.g., by the presence of foreign particles between the probe and the coating.

The probe tip shall be checked frequently for cleanliness.

## 5.8 Probe pressure

The pressure with which the probe is applied to the test specimen affects the instrument readings and shall therefore be made constant.

This pressure effect is more noticeable when the coatings are soft. Most commercially-available instruments are supplied with constant pressure probes.

## 5.9 Probe tilt

Unless otherwise instructed by the manufacturer, the probe shall be applied perpendicularly to the coating surface as tilting the probe away from the perpendicular can cause measurement errors.

The possibility of tilt occurring inadvertently can be minimized by probe design or by the use of a probe-holding jig.

## 5.10 Temperature effects

Because temperature changes affect the characteristics of the probe, it should be used under approximately the same temperature conditions as those used for calibration unless the probe has built-in temperature compensation.

Most metals change their electrical conductivity with temperature. Because the measured coating thickness is influenced by changes in the electrical conductivity of the basis metal, large temperature changes should be avoided.

## 5.11 Intermediate coatings

The presence of an intermediate coating can affect the measurement of the coating thickness if the electrical characteristics of that intermediate coating differ from that of the coating or basis material. If a difference does exist then the measurements will, in addition, be affected by an intermediate coating thickness of less than

$d_{\min}$ . If the thickness is greater than  $d_{\min}$  then the intermediate coating, if non-magnetic, can be treated as the basis material.

It has been found that some instruments having probe systems operating with multiple frequencies can measure both top and intermediate coatings.

## 6 Procedure

### 6.1 Calibration of instruments

#### 6.1.1 General

Before use, each instrument shall be calibrated in accordance with the manufacturer's instructions, using suitable calibration standards. Particular attention shall be paid to the description given in Clause 3 and to the factors described in Clause 5.

In order to minimize conductivity changes due to temperature variations, at the time of calibration the instrument and the calibration standards shall be at a temperature close to the temperature of the items to be measured.

NOTE Calibration checks should also be carried out as necessary during the determinations to avoid instrument drift.

#### 6.1.2 Calibration standards

Instrument calibration shall be made using at least two standards of different and known thicknesses. One of these standards may be of the uncoated basis material.

NOTE 1 Such standards should have their thicknesses traceable to a certifiable source.

The electrical conductivity and magnetic permeability of both coating and basis materials shall be identical to those properties of the parts to be measured.

NOTE 2 As calibration standards are subject to wear and deterioration with time and use, they should be recalibrated and/or replaced periodically at time intervals established locally or after consultation with the manufacturer.

#### 6.1.3 Verification

The electrical properties of the basis material of the calibration standards shall be similar to those of the basis material of the test specimen.

NOTE To confirm their suitability, the readings obtained with the basis material of the uncoated calibration standard and with that of the test specimen should be compared.

If the basis material thickness exceeds the critical thickness, as defined in 5.3, the thickness measurement is not affected by the thickness of the basis material.

If the critical thickness is not exceeded, the thickness of the basis material for the test and for the calibration shall be the same. If, under practical conditions, this is not possible then it may be possible to back either the standard or the test specimen with a sufficient thickness of a material having similar electrical properties to make the readings independent of the basis material thickness. If this method is used, tests shall be undertaken to confirm that it is acceptable and to establish the presence of any additional errors.

If the curvature of the coated surface to be measured is such as to preclude calibration on a flat surface, the standards used for calibration shall have the same radii of curvature as the specimen to be measured, unless a special probe that compensates for the curvature influence is used.

## 6.2 Determination

### 6.2.1 General

Operate each instrument in accordance with the manufacturer's instructions, giving appropriate attention to the factors given in Clause 5.

Check the calibration of the instrument, using valid calibration standards, at the test site each time the instrument is put into service and at frequent intervals during use (at least once per hour) to ensure proper performance (see 6.1).

The precautions listed in 6.2.2 to 6.2.6 shall be observed.

### 6.2.2 Surface cleanliness

Before making measurements, remove any foreign matter such as dirt, oil, grease and corrosion products from the surface of standards and test specimen, without removing any coating material.

### 6.2.3 Basis metal thickness

Check that the basis material exceeds the critical thickness (see 5.3). If it does not, either use the back-up method described in 6.1.3 or ensure that the calibration was carried out on a calibration standard having the same thickness and electrical properties as the test specimen.

### 6.2.4 Edge effects

Do not make measurements close to an edge, hole, inside corner, etc., of a test specimen unless the validity of the calibration for such measurements has been demonstrated (see Annex B).

### 6.2.5 Curvature

Do not make measurements on a curved surface of a test specimen, unless the validity of the calibration for such measurements has been demonstrated.

### 6.2.6 Number of readings

A number of measurements made on the same spot, if necessary using a probe jig, will provide information on the repeatability (standard deviation) of the instrument and its probe at that time and at the thickness being measured.

NOTE A coefficient of variation,  $V$ , can be calculated from this standard deviation.  $V$  can be applied to a range of thicknesses.

A number of measurements made by moving the probe between each measurement, and within a specified area on the coated surface, will provide information on the repeatability of the instrument and coating within that specified area.

If a coating surface is rough or the test specimens are known to have large thickness gradients across their surfaces (e.g. because of size and/or shape) the origins of measurement variations should be established by multiple measurements.

## 7 Expression of results

The expression and presentation of results shall be agreed between interested parties and normally includes:

- a list of all the readings taken;
- the mean, maximum, minimum readings;
- the standard deviation and/or coefficient of variation.

## 8 Measurement uncertainty

The instrument, its calibration, and its operation shall be such that the coating thickness can be determined to within 10 % of its true thickness.

## 9 Test report

The test report shall include the following information:

- a) all information necessary for the identification of the test specimen;
- b) a reference to this standard, including its date of publication, i.e., ISO 2360:2003;
- c) the sizes of the test areas, in square millimetres, over which the measurements were made;

NOTE Other units of measurement may be used upon agreement between supplier and client.

- d) the location(s) of the test area(s) on each specimen;
- e) the number of test specimens measured;
- f) the measured thicknesses, in micrometres, at each area at which the tests were carried out and the number of measurements averaged and the standard deviation for each reported measurement;
- g) the name of the operator and testing laboratory;
- h) the date on which the measurements were made;
- i) any unusual features observed and any circumstances or conditions thought likely to affect the results or their validity;
- j) any deviation from the method specified;
- k) an identification of the instrument, probe and standards used for the tests, including reference to any validation certification of the equipment.

## Annex A (informative)

### Eddy current generation in a metallic conductor

#### A.1 General

Eddy current instruments work on the principle that a high frequency electromagnetic field generated by the probe system of the instrument will produce eddy currents in an electrical conductor on which the probe is placed. These currents result in a change of the amplitude and/or the phase of the probe coil impedance, which can be used as a measure of the thickness of the coating on the conductor (see Example 1) or of the conductor itself (see Example 2).

Figure A.1 represents eddy current generation in a metal conductor and Figure A.2 is a vector representation of eddy current generation.

#### Key

- 1 probe (containing eddy current generator)
- 2 eddy currents set up in the metal conductor by the magnetic field
- 3 oscillating electromagnetic field generated by the probe
- 4 coating (item being measured)
- 5 basis material

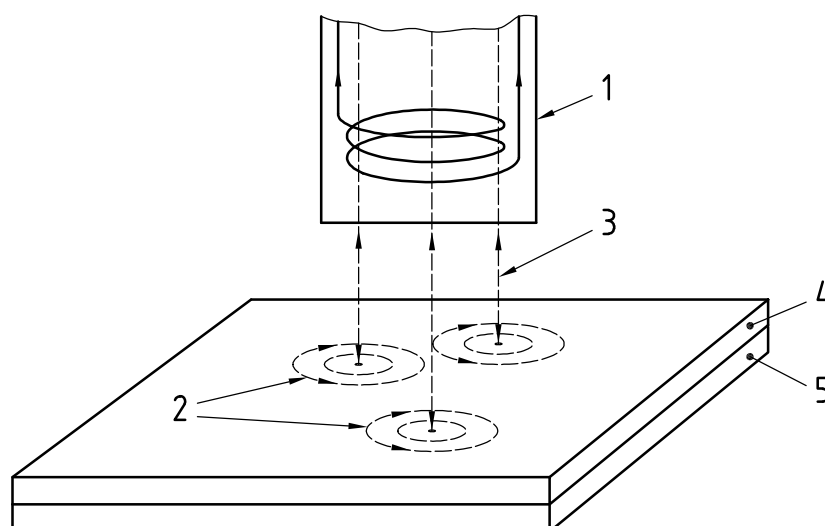
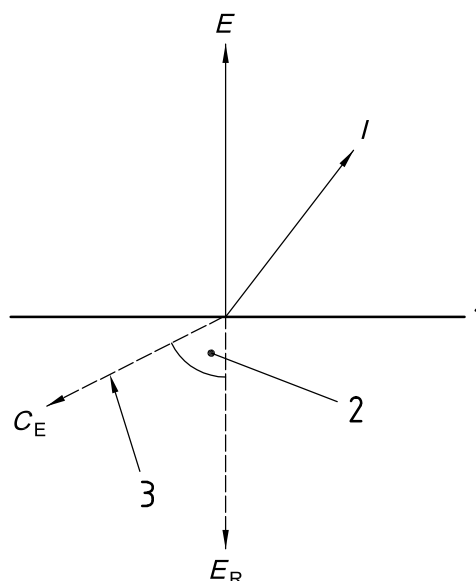

**Figure A.1 — Schematic representation of eddy current generation in a metal conductor**

The eddy current density  $J(\delta)$  changes its magnitude with increasing distance from the surface of the conductor. At the depth  $\delta_0$  (standard penetration depth) the electromagnetic field and consequently the current density drops to  $\frac{J(0)}{J(\delta_0)} = \frac{1}{e}$ .

**Key**

- 1 real component of probe impedance
- 2 phase angle
- 3 amplitude (vector length)
- $E$  probe potential
- $I$  probe current
- $E_R$  reverse potential
- $C_E$  eddy current (generated in the conductor)



**Figure A.2 — Vector representation of eddy current generation**

The standard penetration depth,  $\delta_0$ , is a useful value for some important rough estimations. It may be calculated, in mm, using the equation:

$$\delta_0 = \frac{503}{\sqrt{f \cdot \sigma \cdot \mu_r}} \quad (\text{A.1})$$

where

$f$  is the probe operating frequency, in Herz;

$\sigma$  is the electrical conductivity of the conductor, in megasiemens per metre;

$\mu_r$  is the relative permeability of the conductor (for non magnetic materials  $\mu_r = 1$ ).

The amplitude-sensitive eddy current method is best suited to the measurement of non-conductive coatings on non-magnetic basis metals (see Example 1) but also to bare non-magnetic metallic coatings on non-conductive basis materials (see Example 2). The phase-sensitive eddy current method (see ISO 21968) is best suited to the measurement of non-magnetic metallic coatings on metallic or non-metallic basis materials (see Example 2) especially if the metallic coating has to be measured through paint or a contactless measurement is necessary, i.e. a “Lift-off” compensation is necessary

## A.2 Example 1 — Non-conductive coating on a conductive basis material

In this case the eddy current density is only determined by the distance between the probe and the basis metal, i.e. the coating thickness. In order to achieve this the base material is thicker than the minimum basis material thickness. This minimum thickness,  $d_{\min}$ , in mm, can be estimated as (see 5.3.):

$$d_{\min} = 2,5 \delta_0 \quad (\text{A.2})$$

If the basis material thickness is lower than this minimum thickness,  $d_{\min}$ , the measured value of the coating thickness will be affected.



### A.3 Example 2 — Conductive coating on a non-conductive basis material

In this case the eddy current density is determined only by the thickness of the conductive coating. The approximate maximum measurable thickness,  $d_{\max}$ , in mm, may be calculated from the equation:

$$d_{\max} = 0,8 \delta_0 \quad (\text{A.3})$$

i.e. the thickness range is limited by the penetration depth  $\delta_0$  and if the conductive coating thickness is further increased, it will have no further influence on the generated eddy currents.

NOTE  $d_{\max}$  is sometimes called “saturation thickness”.

## Annex B (normative)

### Test for edge effect

A simple edge effect test, to assess the effect of the proximity of an edge, consists in using a clean uncoated sample of the basis metal as follows. The procedure is illustrated in Figure B.1.

#### Step 1

Place the probe on the sample, well away from the edge.

#### Step 2

Adjust the instrument to read zero.

#### Step 3

Progressively bring the probe towards the edge and note where a change of the instrument reading occurs with respect to the expected uncertainty or to the given thickness.

#### Step 4

Measure the distance,  $d$ , from the probe to the edge (see Figure B.1).

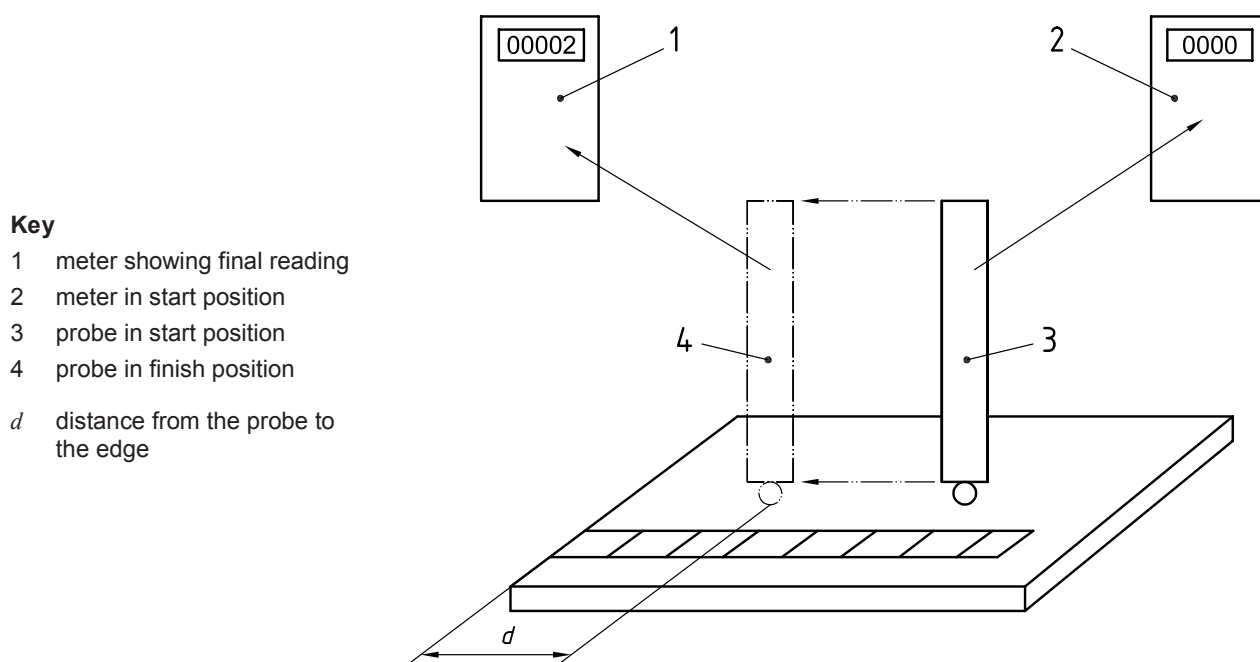

Figure B.1 — Schematic representation of the test for edge effect

The instrument may be used without correction provided that the probe is further from the edge than the distance as measured above. If the probe is used closer to the edge, special calibration correction is required. If necessary, refer to the manufacturer's instructions.

If the sample to be measured is not flat, then an uncoated sample should be used that is representative both in size and shape.

## Bibliography

- [1] ISO 2178, *Non-magnetic coatings on magnetic substrates — Measurement of coating thickness — Magnetic method*
- [2] ISO 21968, *Non-magnetic metallic coatings on metallic and non-metallic basis materials — Measurement of coating thickness — Phase-sensitive eddy current method*

---

---

## BSI — British Standards Institution

BSI is the independent national body responsible for preparing British Standards. It presents the UK view on standards in Europe and at the international level. It is incorporated by Royal Charter.

### Revisions

British Standards are updated by amendment or revision. Users of British Standards should make sure that they possess the latest amendments or editions.

It is the constant aim of BSI to improve the quality of our products and services. We would be grateful if anyone finding an inaccuracy or ambiguity while using this British Standard would inform the Secretary of the technical committee responsible, the identity of which can be found on the inside front cover.  
Tel: +44 (0)20 8996 9000. Fax: +44 (0)20 8996 7400.

BSI offers members an individual updating service called PLUS which ensures that subscribers automatically receive the latest editions of standards.

### Buying standards

Orders for all BSI, international and foreign standards publications should be addressed to Customer Services. Tel: +44 (0)20 8996 9001.  
Fax: +44 (0)20 8996 7001. Email: [orders@bsi-global.com](mailto:orders@bsi-global.com). Standards are also available from the BSI website at <http://www.bsi-global.com>.

In response to orders for international standards, it is BSI policy to supply the BSI implementation of those that have been published as British Standards, unless otherwise requested.

### Information on standards

BSI provides a wide range of information on national, European and international standards through its Library and its Technical Help to Exporters Service. Various BSI electronic information services are also available which give details on all its products and services. Contact the Information Centre.  
Tel: +44 (0)20 8996 7111. Fax: +44 (0)20 8996 7048. Email: [info@bsi-global.com](mailto:info@bsi-global.com).

Subscribing members of BSI are kept up to date with standards developments and receive substantial discounts on the purchase price of standards. For details of these and other benefits contact Membership Administration.  
Tel: +44 (0)20 8996 7002. Fax: +44 (0)20 8996 7001.  
Email: [membership@bsi-global.com](mailto:membership@bsi-global.com).

Information regarding online access to British Standards via British Standards Online can be found at <http://www.bsi-global.com/bsonline>.

Further information about BSI is available on the BSI website at <http://www.bsi-global.com>.

### Copyright

Copyright subsists in all BSI publications. BSI also holds the copyright, in the UK, of the publications of the international standardization bodies. Except as permitted under the Copyright, Designs and Patents Act 1988 no extract may be reproduced, stored in a retrieval system or transmitted in any form or by any means – electronic, photocopying, recording or otherwise – without prior written permission from BSI.

This does not preclude the free use, in the course of implementing the standard, of necessary details such as symbols, and size, type or grade designations. If these details are to be used for any other purpose than implementation then the prior written permission of BSI must be obtained.

Details and advice can be obtained from the Copyright & Licensing Manager.  
Tel: +44 (0)20 8996 7070. Fax: +44 (0)20 8996 7553.  
Email: [copyright@bsi-global.com](mailto:copyright@bsi-global.com).