

BS EN ISO 1660:2017



BSI Standards Publication

**Geometrical product  
specifications (GPS) —  
Geometrical tolerancing  
— Profile tolerancing (ISO  
1660:2017)**

**National foreword**

This British Standard is the UK implementation of EN ISO 1660:2017. It supersedes BS EN ISO 1660:1996 which is withdrawn.

The UK participation in its preparation was entrusted to Technical Committee TDW/4, Technical Product Realization.

A list of organizations represented on this committee can be obtained on request to its secretary.

This publication does not purport to include all the necessary provisions of a contract. Users are responsible for its correct application.

© The British Standards Institution 2017.  
Published by BSI Standards Limited 2017

ISBN 978 0 580 83261 1

ICS 01.100.01

**Compliance with a British Standard cannot confer immunity from legal obligations.**

This British Standard was published under the authority of the Standards Policy and Strategy Committee on 28 February 2017.

**Amendments/Corrigenda issued since publication**

Date	Text affected
------	---------------

---

EUROPEAN STANDARD

**EN ISO 1660**

NORME EUROPÉENNE

EUROPÄISCHE NORM

February 2017

ICS 01.100.01; 17.040.40

Supersedes EN ISO 1660:1995

English Version

## Geometrical product specifications (GPS) - Geometrical tolerancing - Profile tolerancing (ISO 1660:2017)

Spécification géométrique des produits (GPS) -  
Tolérancement géométrique - Tolérancement des  
profils (ISO 1660:2017)

Geometrische Produktspezifikation (GPS) -  
Geometrische Tolerierung - Profiltolerierung (ISO  
1660:2017)

This European Standard was approved by CEN on 14 December 2016.

CEN members are bound to comply with the CEN/CENELEC Internal Regulations which stipulate the conditions for giving this European Standard the status of a national standard without any alteration. Up-to-date lists and bibliographical references concerning such national standards may be obtained on application to the CEN-CENELEC Management Centre or to any CEN member.

This European Standard exists in three official versions (English, French, German). A version in any other language made by translation under the responsibility of a CEN member into its own language and notified to the CEN-CENELEC Management Centre has the same status as the official versions.

CEN members are the national standards bodies of Austria, Belgium, Bulgaria, Croatia, Cyprus, Czech Republic, Denmark, Estonia, Finland, Former Yugoslav Republic of Macedonia, France, Germany, Greece, Hungary, Iceland, Ireland, Italy, Latvia, Lithuania, Luxembourg, Malta, Netherlands, Norway, Poland, Portugal, Romania, Serbia, Slovakia, Slovenia, Spain, Sweden, Switzerland, Turkey and United Kingdom.



EUROPEAN COMMITTEE FOR STANDARDIZATION  
COMITÉ EUROPÉEN DE NORMALISATION  
EUROPÄISCHES KOMITEE FÜR NORMUNG

**CEN-CENELEC Management Centre: Avenue Marnix 17, B-1000 Brussels**

## **European foreword**

This document (EN ISO 1660:2017) has been prepared by Technical Committee ISO/TC 213 “Dimensional and geometrical product specifications and verification” in collaboration with Technical Committee CEN/TC 290 “Dimensional and geometrical product specification and verification” the secretariat of which is held by AFNOR.

This European Standard shall be given the status of a national standard, either by publication of an identical text or by endorsement, at the latest by August 2017 and conflicting national standards shall be withdrawn at the latest by August 2017.

Attention is drawn to the possibility that some of the elements of this document may be the subject of patent rights. CEN [and/or CENELEC] shall not be held responsible for identifying any or all such patent rights.

This document supersedes EN ISO 1660:1995.

According to the CEN-CENELEC Internal Regulations, the national standards organizations of the following countries are bound to implement this European Standard: Austria, Belgium, Bulgaria, Croatia, Cyprus, Czech Republic, Denmark, Estonia, Finland, Former Yugoslav Republic of Macedonia, France, Germany, Greece, Hungary, Iceland, Ireland, Italy, Latvia, Lithuania, Luxembourg, Malta, Netherlands, Norway, Poland, Portugal, Romania, Serbia, Slovakia, Slovenia, Spain, Sweden, Switzerland, Turkey and the United Kingdom.

### **Endorsement notice**

The text of ISO 1660:2017 has been approved by CEN as EN ISO 1660:2017 without any modification.

# Contents

	Page
<b>Foreword</b> .....	<b>iv</b>
<b>Introduction</b> .....	<b>v</b>
<b>1 Scope</b> .....	<b>1</b>
<b>2 Normative references</b> .....	<b>1</b>
<b>3 Terms and definitions</b> .....	<b>1</b>
<b>4 Symbols</b> .....	<b>2</b>
<b>5 Rules for profile tolerancing</b> .....	<b>3</b>
5.1 General.....	3
5.2 Default rules for profile tolerancing.....	4
5.2.1 Rule A: Definition of the theoretically exact feature (TEF).....	4
5.2.2 Rule B: Type of toleranced feature.....	5
5.2.3 Rule C: Definition of the tolerance zone.....	5
5.3 Rules for profile tolerancing using additional specification elements.....	7
5.3.1 Rule D: Toleranced feature specification elements.....	7
5.3.2 Rule E: Unequally disposed tolerance zone.....	8
5.3.3 Rule F: Linear tolerance zone offset.....	8
5.3.4 Rule G: Angular tolerance zone offset.....	8
5.3.5 Rule H: Variable tolerance zone width.....	8
5.3.6 Rule I: Filtered feature specification elements.....	8
5.3.7 Rule J: Association and parameter specification elements.....	9
5.3.8 Rule K: Associated toleranced feature specification elements.....	9
5.3.9 Rule L: Non-rigid part.....	9
<b>Annex A (informative) Compound features</b> .....	<b>10</b>
<b>Annex B (informative) Illustration of the rules</b> .....	<b>12</b>
<b>Annex C (informative) Former practices</b> .....	<b>42</b>
<b>Annex D (informative) Relation to the GPS matrix model</b> .....	<b>44</b>
<b>Bibliography</b> .....	<b>45</b>

## Foreword

ISO (the International Organization for Standardization) is a worldwide federation of national standards bodies (ISO member bodies). The work of preparing International Standards is normally carried out through ISO technical committees. Each member body interested in a subject for which a technical committee has been established has the right to be represented on that committee. International organizations, governmental and non-governmental, in liaison with ISO, also take part in the work. ISO collaborates closely with the International Electrotechnical Commission (IEC) on all matters of electrotechnical standardization.

The procedures used to develop this document and those intended for its further maintenance are described in the ISO/IEC Directives, Part 1. In particular the different approval criteria needed for the different types of ISO documents should be noted. This document was drafted in accordance with the editorial rules of the ISO/IEC Directives, Part 2 (see [www.iso.org/directives](http://www.iso.org/directives)).

Attention is drawn to the possibility that some of the elements of this document may be the subject of patent rights. ISO shall not be held responsible for identifying any or all such patent rights. Details of any patent rights identified during the development of the document will be in the Introduction and/or on the ISO list of patent declarations received (see [www.iso.org/patents](http://www.iso.org/patents)).

Any trade name used in this document is information given for the convenience of users and does not constitute an endorsement.

For an explanation on the meaning of ISO specific terms and expressions related to conformity assessment, as well as information about ISO's adherence to the World Trade Organization (WTO) principles in the Technical Barriers to Trade (TBT) see the following URL: [www.iso.org/iso/foreword.html](http://www.iso.org/iso/foreword.html).

This document was prepared by Technical Committee ISO/TC 213, *Dimensional and geometrical product specifications and verification*.

This third edition cancels and replaces the second edition (ISO 1660:1987), which has been technically revised with the following changes:

- the requirements for defining the theoretically exact feature (the nominal geometry) have been made more explicit;
- the definition of what constitutes the toleranced feature has been clarified and updated to follow the feature principle, (see ISO 8015:2011, 5.5);
- tools for defining specifications for restricted features and compound features have been added;
- tools for defining specifications using unequally disposed or offset tolerance zones have been added;
- tools for defining specifications using tolerance zone of variable width have been added.

## Introduction

This document is a geometrical product specification (GPS) standard and is to be regarded as a general GPS standard (see ISO 14638). It influences the chain links A, B and C of the chains of standards on form, orientation and location.

The ISO GPS Masterplan given in ISO 14638 gives an overview of the ISO GPS system of which this document is a part. The fundamental rules of ISO GPS given in ISO 8015 apply to this document and the default decision rules given in ISO 14253-1 apply to specifications made in accordance with this document, unless otherwise indicated.

For more detailed information of the relation of this document to the GPS matrix model, see [Annex D](#).

This document provides rules for profile tolerancing.

For the presentation of lettering (proportions and dimensions), see ISO 3098-2.

All figures in this document for the 2D drawing indications have been drawn in first-angle projection with dimensions and tolerances in millimetres. It should be understood that third-angle projection and other units of measurement could have been used equally well without prejudice to the principles established. For all figures giving specification examples in 3D, the dimensions and tolerances are the same as for the similar figures shown in 2D.

The figures in this document represent either 2D drawing views or 3D axonometric views on 2D drawings and are intended to illustrate how a specification can be fully indicated with visible annotation. For possibilities of illustrating a specification, where elements of the specification may be available through a query function or other interrogation of information in the 3D CAD model and rules for attaching specifications to 3D CAD models, see ISO 16792.

The figures in this document illustrate the text and are not intended to reflect an actual application. Consequently, the figures are not fully dimensioned and specified, showing only the relevant general principles. Neither are the figures intended to imply a particular display requirement in terms of whether hidden detail, tangent lines or other annotations are shown or not shown. Many figures have lines or details removed for clarity, or added or extended to assist with the illustration of the text. See [Table 1](#) for the line types used in definition figures.

In order for a GPS specification to be unambiguous, the partition defining the boundary of the toleranced feature, as well as the filtering should be well defined. Currently, the detailed rules for partitioning and the default for filtering are not defined in GPS standards.

For a definitive presentation (proportions and dimensions) of symbols for geometrical tolerancing, see ISO 7083 and ISO 1101:2017, Annex F.

For the purposes of this document, the terms “axis” and “median plane” are used for derived features of perfect form, and the terms “median line” and “median surface” for derived features of imperfect form. Furthermore, the following line types have been used in the explanatory illustrations, i.e. those representing non-technical drawings for which the rules of ISO 128 (all parts) apply.

**Table 1**

Feature level	Feature type	Details	Line type	
			Visible	Behind plane/ surface
Nominal feature	integral feature	point line/axis surface/plane	wide continuous	narrow dashed
	derived feature	point line/axis surface/plane	narrow long dashed dotted	narrow dashed dotted
Real feature	integral feature	surface	wide freehand continuous	narrow freehand dashed
Extracted feature	integral feature	point line surface	wide short dashed	narrow short dashed
	derived feature	point line surface	wide dotted	narrow dotted
Filtered feature	integral feature	line surface	continuous narrow	continuous narrow
Associated feature	integral feature	point straight line plane	wide doubled-dashed double-dotted	narrow double- dashed double- dotted
	derived feature	point straight line (axis) plane	narrow long dashed double-dotted	wide dashed double-dotted
	datum	point line/axis surface/plane	wide long dashed double-short dashed	narrow long dashed double-short dashed
Tolerance zone limits, tolerance planes		line surface	continuous narrow	narrow dashed
Section, illustration plane, drawing plane, aid plane		line surface	narrow long dashed short dashed	narrow dashed short dashed
Extension, dimension, leader and reference lines		line	continuous narrow	narrow dashed

Contrary to other kinds of geometrical tolerancing, profile tolerancing also allows geometrical tolerancing of non-straight lines and non-flat surfaces, in addition to simpler features, such as planes, cylinders, etc. This makes profile tolerancing more complex than other geometrical tolerancing with respect to the definition of the nominal geometry and the extent of the tolerated feature. This document expands on and provides tools and rules for these two complexities.

This edition of ISO 1660 is a pilot project for writing rule-based standards for geometrical tolerancing rather than example-based standards. In the long term, it is envisioned that the content of this document will be integrated into a future rule-based ISO 1101.



This document references other standards for rules for GPS tolerancing in general and geometrical tolerancing in particular, rather than repeating those rules. These GPS principles and rules include, but are not limited to:

- the feature principle (see ISO 8015:2011, 5.4);
- the independency principle (see ISO 8015:2011, 5.5);
- the rules for implicit TEDs (see ISO 5458:1998, 4.3);
- the width of the tolerance zone applies normal to the toleranced feature (See ISO 1101:2017, Clause 7);
- the rules for identifying the toleranced features (see ISO 1101:2017, Clause 6 and 9.1);
- form specifications, i.e. specifications without reference to a datum, a datum system or a pattern, constrain neither orientation nor location (see ISO 1101:2017, 4.8);
- the tolerance zone can be constrained by reference to datums (see ISO 5459).



# Geometrical product specifications (GPS) — Geometrical tolerancing — Profile tolerancing

**IMPORTANT** — The illustrations included in this document are intended to illustrate the text and/or to provide examples of the related technical drawing specification; these illustrations are not fully dimensioned and toleranced, showing only the relevant general principles. In particular, the illustrations do not contain filter specifications. As a consequence, the illustrations are not a representation of a complete workpiece and are not of a quality that is required for use in industry (in terms of full conformity with the standards prepared by ISO/TC 10 and ISO/TC 213), and as such are not suitable for projection for teaching purposes.

## 1 Scope

This document gives the rules for geometrical specifications of integral and derived features, using the line profile and surface profile characteristic symbols as defined in ISO 1101.

## 2 Normative references

The following documents are referred to in the text in such a way that some or all of their content constitutes requirements of this document. For dated references, only the edition cited applies. For undated references, the latest edition of the referenced document (including any amendments) applies.

ISO 1101:2017, *Geometrical product specifications (GPS) — Geometrical tolerancing — Tolerances of form, orientation, location and run-out*

ISO 5459:2011, *Geometrical product specifications (GPS) — Geometrical tolerancing — Datums and datum systems*

ISO 8015:2011, *Geometrical product specifications (GPS) — Fundamentals — Concepts, principles and rules*

ISO 16792, *Technical product documentation — Digital product definition data practices*

ISO 17450-1, *Geometrical product specifications (GPS) — General concepts — Part 1: Model for geometrical specification and verification*

ISO 17450-3, *Geometrical product specifications (GPS) — General concepts — Part 3: Toleranced features*

ISO 22432, *Geometrical product specifications (GPS) — Features utilized in specification and verification*

## 3 Terms and definitions

For the purposes of this document, the terms and definitions given in ISO 1101, ISO 5459, ISO 8015, ISO 17450-1, ISO 17450-3, ISO 22432 and the following apply.

ISO and IEC maintain terminological databases for use in standardization at the following addresses:

- IEC Electropedia: available at <http://www.electropedia.org/>
- ISO Online browsing platform: available at <http://www.iso.org/obp>

### 3.1

#### **profile tolerancing**

geometrical tolerancing using the line profile symbol or the surface profile symbol

**3.2**  
**line profile**  
property of a line

**3.3**  
**surface profile**  
property of a surface

**3.4**  
**non-redundant degree of freedom**  
degree of freedom for which the tolerance zone is not invariant

## 4 Symbols

See [Table 2](#).

**Table 2 — Symbols for geometrical characteristics**

∩	Line profile symbol
∪	Surface profile symbol

These symbols shall be used in the characteristic section of the tolerance indicator, see ISO 1101:2017, 8.2.

The nominal features, for which each symbol can be used, are given in [Table 3](#).

**Table 3 — Valid geometrical characteristic symbol and nominal toleranced feature combinations**







Toleranced feature	∩	∪
Integral straight line	X	
Derived straight line	X	
Integral non-straight line	X	
Derived non-straight line	X	
Integral flat surface		X
Derived flat surface		X
Integral non-flat surface		X
Derived non-flat surface		X

For straight lines and planes, there are other characteristic symbols that directly provide the information about the shape of the toleranced feature, e.g. flatness for planes and straightness for straight lines. The profile characteristic symbols may be used for straight lines and planes. However, in this case, to determine the nominal shape of the toleranced feature, it is necessary to verify that there is no indication that the feature is nominally non-flat or non-straight on the drawing or in the CAD model, as applicable.

**NOTE** A nominally planar surface and a nominally curved surface with a large radius may both appear as a straight line on the drawing and the profile characteristic symbols can be used for both types of surfaces. However, for the curved surface there will be an indication on the drawing or explicit or implicit TEDs in the CAD model, that the surface is not flat. For the planar surface, there will be no such indication on a drawing. On a drawing, it is this indication or absence of indication that is used to determine the nominal shape of the feature in this case. In a CAD model, the model data are used to determine the nominal shape of the feature.

Additional symbols used in this document are given in [Table 4](#) along with a reference to where they are defined.

**Table 4 — Additional symbols used in this document**

Description	Symbol	Reference
Combined zone	CZ	ISO 1101:2017, 8.2.2.1.2
Separate zones	SZ	ISO 1101:2017, 8.2.2.1.2
Unspecified linear tolerance zone offset	OZ	ISO 1101:2017, 8.2.2.1.4.1
Specified tolerance zone offset	UZ	ISO 1101:2017, 8.2.2.1.3
United feature	UF	ISO 1101:2017, 3.9
Between		ISO 1101:2017, 9.1.4
Unspecified angular tolerance zone offset	VA	ISO 1101:2017, 8.2.2.1.4.2
All around		ISO 1101:2017, 9.1.2
All over		ISO 1101:2017, 9.1.2
Collection plane indicator		ISO 1101:2017, 16
Intersection plane indicator		ISO 1101:2017, 13
Direction feature indicator		ISO 1101:2017, 15
Orientation constraint only	><	ISO 5459:2011, 7.4.2.8

## 5 Rules for profile tolerancing

### 5.1 General

For the basic rules for geometrical tolerancing, of which profile tolerancing is a part, see ISO 1101.

When a drawing shall be used in conjunction with a CAD model, an unambiguous reference to the CAD model shall be made on the drawing and the CAD model shall comply with ISO 16792.

According to the feature principle (see ISO 8015:2011, 5.4), by default a profile specification applies to one complete single feature as defined in ISO 22432. It is the designer's responsibility to select the features or parts of features to which a specification applies and either indicate that on a 2D drawing using appropriate symbology or define it in the CAD model.

According to the independency principle (see ISO 8015:2011, 5.5), by default a profile specification that applies to more than one single feature as defined in ISO 22432, applies to those features independently. If it is desired that the profile specification applies to the features as if they were one, or with some constraint amongst the tolerance zones for the single features, it is the designer's responsibility to either indicate this on a 2D drawing using appropriate symbology or define it in the CAD model.

The "all over" indication and the "all around" indication shall always be combined with UF, CZ or SZ, when used for geometrical tolerancing, to make it explicit whether the specification applies to a united feature, defines a combined zone or defines a set of separate zones, except when all the non-redundant degrees of freedom for all the tolerance zones are locked by reference to datums.

NOTE 1 The meaning of CZ and SZ is identical when the specification defines a set of tolerance zones for which all non-redundant degrees of freedom are locked by reference to datums.

NOTE 2 In previous revisions of this document, "all around" was used without any other indication. That made it ambiguous whether the specification applied to the features independently or the specification defined a combined zone. The requirement to always use UF, CZ or SZ is a failsafe indication.

## 5.2 Default rules for profile tolerancing

### 5.2.1 Rule A: Definition of the theoretically exact feature (TEF)

The theoretically exact feature (TEF) of the tolerated feature shall be defined with theoretically exact dimensions (TEDs) or be embedded in the CAD model. For a feature of size, the nominal shape of the TEF shall be defined, but the nominal size of the TEF may be undefined, see [Figure 4 b](#)).

These TEDs may include:

- explicit TEDs;
- implicit TEDs;
- tables of values and interpolation algorithms;
- mathematical functions including splines and other formulae;
- reference to CAD model queries.

A TEF that appears to be a nominally straight line or a nominal plane on the drawing with no explicit indication to the contrary, shall be considered a nominally straight line or a nominal plane, respectively, defined by implicit TEDs.

The shape of a TEF that is nominally a circle, a cylinder, a sphere or a cone is implicitly defined.

The shape of a TEF that is nominally a torus is defined when the directrix size is defined by an explicit TED.

The size of a feature of size is undefined, and shall therefore be considered variable, unless it is defined by an explicit TED, see [Figures 1](#) and [4](#). The size of the generatrix of a torus is undefined, unless it is defined by an explicit TED. See also rules F and G.

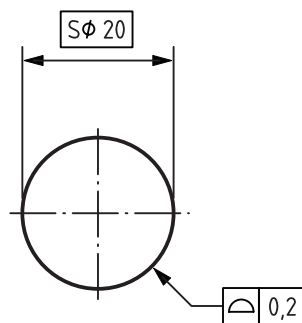

NOTE The diameter of the median surface of the tolerance zone is fixed at the nominal size.

**Figure 1 — Surface profile specification for a sphere of defined nominal size, given by a TED**

If the TEF of a feature is defined by a table with sets of coordinates, the interpolation algorithm for defining points between the given coordinates shall also be defined.

NOTE 1 There is no standardized way to indicate the interpolation algorithm.

NOTE 2 A non-exhaustive list of interpolation algorithms includes:

- linear interpolation;
- cubic spline interpolation (with or without periodicity conditions);
- NURBS.

EXAMPLE The points are connected by straight lines.

When the TEF is embedded in the CAD model, it shall comply with ISO 16792.

### 5.2.2 Rule B: Type of toleranced feature

The rules for indicating whether the toleranced feature is an integral feature or a derived feature are given in ISO 1101:2017, Clause 6.

When the characteristic symbol in the tolerance indicator is the surface profile symbol, the toleranced feature is an integral or derived surface.

When the characteristic symbol in the tolerance indicator is the line profile symbol, the toleranced feature is either

- the derived feature (see [B.15](#)),
- any line in the identified integral or derived surface, in a specified direction (see [B.14](#)), or
- one specified line in the identified integral or derived surface.

If the toleranced feature is one identified line in a surface, the location of this line shall be identified by TEDs.

If the toleranced feature is any line in the identified surface in a specified direction, then that direction shall be identified using an intersection plane indicator, see ISO 1101:2017, Clause 13.

### 5.2.3 Rule C: Definition of the tolerance zone

See [Figure 2](#).

For surface profile characteristics, the tolerance zone is limited by two surfaces enveloping spheres with a diameter equal to the tolerance value, the centres of which are situated on the TEF (see [Figure 2](#)), unless otherwise specified, see rules E, F and H.

For line profile characteristics, when the tolerance is constant and not preceded by  $\varnothing$ , the tolerance zone is limited by two lines enveloping circles with a diameter equal to the tolerance value, the centres of which are situated on the TEF, unless otherwise specified, see rules E, F and H.

For line profile characteristics, when the toleranced feature is a derived line and the tolerance value is preceded by  $\varnothing$ , the tolerance zone is limited by a tube enveloping spheres with a diameter equal to the tolerance value, the centres of which are situated on the TEF, unless otherwise specified, see rule H.

NOTE See also ISO 1101:2017, 8.2.2.1.1.

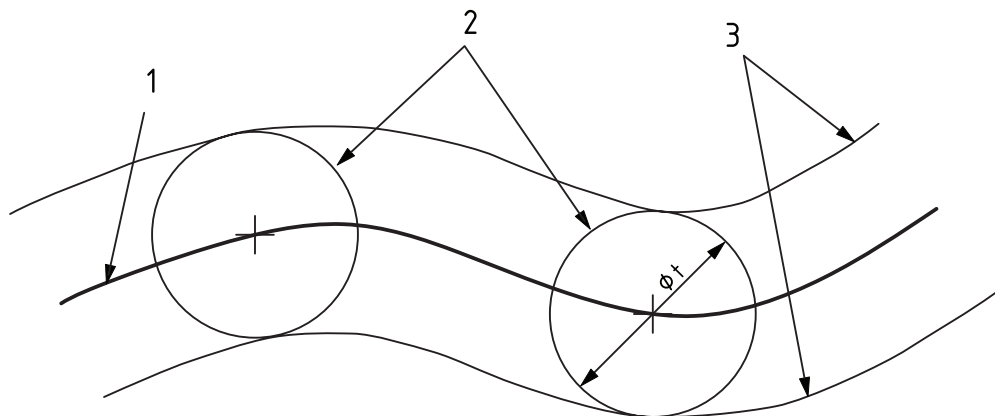

**Key**

- 1 TEF
- 2 two of the infinite number of spheres or circles defining the tolerance zone along the TEF
- 3 tolerance zone limits
- t tolerance value

**Figure 2 — Definition of tolerance zone**

For line profile characteristics for integral features, the orientation of the intersection plane that contains the tolerance zone may be completely defined by the intersection plane indicator, e.g. when it is specified to be parallel to a datum plane or perpendicular to a datum axis.

In other cases, e.g. when it is specified to be perpendicular to a datum plane or parallel to a datum axis, one orientation angle remains unlocked. In this case, the intersection plane shall be perpendicular to the surface, see [Figure 3](#), if being perpendicular to the surface defines a consistent direction for each line profile.

If being perpendicular to the surface does not define a consistent direction along each line profile, e.g. for complex surfaces that are twisted along the line profile, and the intersection plane has an unlocked orientation angle, a direction feature indicator shall be used to define the second orientation angle of the intersection plane.



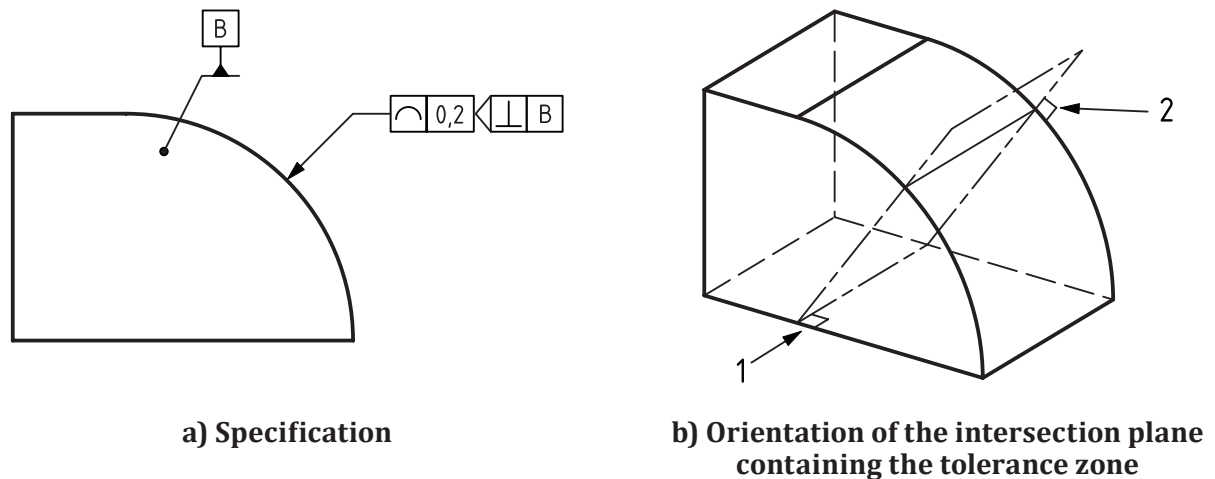

**Key**

- 1 the intersection plane is perpendicular to datum plane B
- 2 the intersection plane is locally perpendicular to the tolerated feature

**Figure 3 — Orientation of the intersection plane that contains the tolerance zone for line profile characteristics**

### 5.3 Rules for profile tolerancing using additional specification elements

#### 5.3.1 Rule D: Toleranced feature specification elements

If the tolerated feature is not one complete single feature, this shall be indicated by using the tools given in ISO 1101, e.g. the SZ, CZ, UF, “all over”, “all around” and “between” specification elements, or by query of the CAD model (see B.5, NOTE 2). To avoid ambiguities, the “all over” and “all around” specification elements shall always be used together with either the SZ, CZ or UF specification element for geometrical specifications, unless all the non-redundant degrees of freedom of the tolerance zones are locked by a datum system.

The SZ, separate zones, modifier considers the set of single features as separate features, with unrelated tolerance zones. Since there are a number of tolerated features, there are an equal number of specified characteristics.

The CZ, combined zone, modifier considers the set of single features as separate features, but combines the tolerance zones. Since it builds a collection of tolerated features, it cannot define a derived feature, if the individual features do not have a derived feature. Therefore, the CZ modifier is appropriate to use when the tolerated features function separately, but with a relation between them. The CZ modifier defines only one specified characteristic.

The UF, united feature, modifier builds one compound feature out of several single features. This compound feature may have a derived feature, even when the individual features do not. Therefore, the UF modifier is appropriate to use when the function(s) is related to the integral compound feature considered as one feature, or to its derived feature.

A specification for a united feature or its derived feature creates one tolerance zone for that compound feature or derived feature. Since there is only one compound feature, there is only one specified characteristic.

In the case of profile tolerancing of integral features, the practical difference between UF and CZ is small and limited to the shape of the tolerance zone in transitions between features.

### 5.3.2 Rule E: Unequally disposed tolerance zone

If, for integral features, the tolerance zone is not equally disposed according to rule C, the UZ specification element shall be used. The rules are given in ISO 1101:2017, 8.2.2.1.3.

### 5.3.3 Rule F: Linear tolerance zone offset

If the tolerance zone is allowed to be offset from the TEF by a consistent, but unspecified amount, the OZ specification element shall be indicated in the tolerance indicator. The rules are given in ISO 1101:2017, 8.2.2.1.4.1.

In the case of a feature of linear size, when a tolerance zone shall not take the nominal size into account, the OZ modifier shall be indicated, see [Figure 4 a\)](#). If the shape of the TEF is defined, but the nominal linear size of the TEF is undefined, the OZ modifier shall always be indicated, see [Figure 4 b\)](#).



a) Surface profile specification for a sphere of defined nominal size, given by a TED with OZ indication

b) Surface profile specification for a sphere of undefined nominal size with OZ indication

NOTE The diameter of the median surface of the tolerance zone is variable.

**Figure 4 — Surface profile specifications features of linear size with OZ modifier**

NOTE Because there are no bounds on the offset, a specification with the OZ modifier, such as the one in [Figure 4 a\)](#) and b), is usually combined with a specification using a larger tolerance without the OZ modifier, such as the one in [Figure 1](#). When both tolerances are satisfied, this combination controls the shape of the tolerance feature within the larger, fixed tolerance zone.

### 5.3.4 Rule G: Angular tolerance zone offset

In the case of a feature of angular size, when a tolerance zone shall not take the nominal size into account, the VA modifier (variable angular size) shall be indicated. If the shape of the TEF is defined, but the nominal angular size of the TEF is undefined, the VA modifier shall always be indicated. The rules are given in ISO 1101:2017, 8.2.2.1.4.2.

### 5.3.5 Rule H: Variable tolerance zone width

If the tolerance zone width is variable, this shall be indicated using the tools given in ISO 1101:2017, 8.2.2.1.1.

### 5.3.6 Rule I: Filtered feature specification elements

If the specification applies to an extracted feature with a specified filtering applied, this shall be indicated using the tools given in ISO 1101:2017, 8.2.2.2.1.

### **5.3.7 Rule J: Association and parameter specification elements**

If an unrelated profile characteristic (profile form specification) applies relative to a non-default reference feature, to a non-default parameter, or both, this shall be indicated using the tools given in ISO 1101:2017, 8.2.2.3.1 and 8.2.2.3.2.

NOTE The default association criterion and parameter are given in ISO 1101:2017, 8.2.2.3.1 and 8.2.2.3.2.

### **5.3.8 Rule K: Associated toleranced feature specification elements**

If the specification applies to an associated feature and not the identified feature itself, this shall be indicated using the tools given in ISO 1101:2017, 8.2.2.2.2.

### **5.3.9 Rule L: Non-rigid part**

If the specification applies to a non-rigid part in a restrained or non-restrained condition, the indications and rules given in ISO 10579 apply.

## Annex A (informative)

### Compound features

Compound features not fully defined by TEDs and features that are of one of the types as given in rule A, but do not meet the requirements of the rule with regards to dimensions defined by TEDs have no unambiguous defined form and therefore cannot be specified by profile characteristics. [Figure A.1](#) shows some examples.

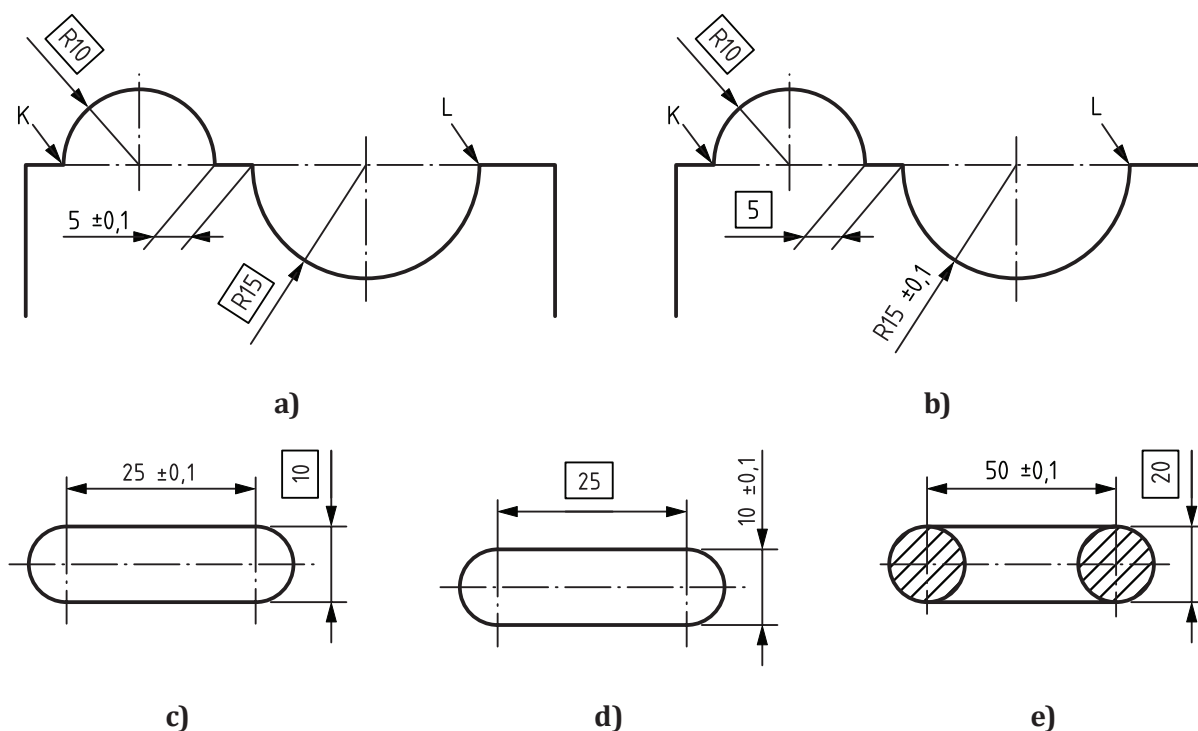

**Figure A.1 — Features with ambiguous geometry**

The TEF of the feature in [Figure A.1](#) a) is ambiguous because the nominal distance between the two half-circles is not defined.

The TEF of the feature [Figure A.1](#) b) is ambiguous because the nominal radius of one of the two half-circles is not defined.

The TEF of the feature in [Figure A.1](#) c) is ambiguous because the nominal distance between the arc centres is not defined.

The TEF of the feature in [Figure A.1](#) d) is ambiguous because the nominal diameter of the arcs is not defined.

The TEF of the feature in [Figure A.1](#) e) is ambiguous because the nominal size of the directrix is not defined.

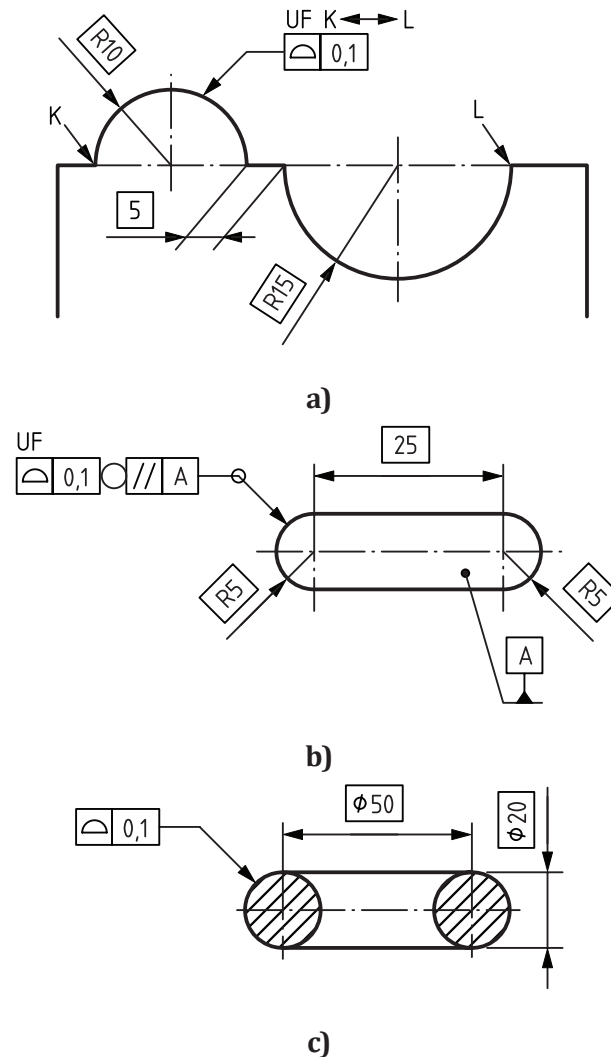

**Figure A.2 — Features with unambiguous geometry**

NOTE 1 CZ could have been used instead of UF in [Figure A.2 a\)](#) and [Figure A.2 b\)](#).

NOTE 2 The distance between the planes in [Figure A.2 b\)](#) is implicitly given as 10, because they are shown tangential to the half cylinders.

The TEF of the feature in [Figure A.2 a\)](#) is unambiguous because the nominal radii of the half-circles as well as the distance between the two circles are defined by explicit and implicit TEDs.

The TEF of the feature in [Figure A.2 b\)](#) is unambiguous because both the nominal diameter of the arcs and the nominal distance between the arc centres are defined by explicit and implicit TEDs.

The TEF of the feature in [Figure A.2 c\)](#) is unambiguous because the nominal size of the directrix is defined by a TED.

## Annex B (informative)

### Illustration of the rules

#### B.1 General

The following examples are intended to illustrate the fundamental rules as well as rules A to F. They do not add to the rules, subtract from the rules or change the rules.

- Example 1: Surface profile specification for a single feature ([B.2](#)).
- Example 2: Surface profile specification for compound feature ([B.3](#)).
- Example 3: Surface profile specification for a set of independent features ([B.4](#)).
- Example 4: Surface profile specification for a united feature ([B.5](#)).
- Example 5: Unequally disposed surface profile specification for a united feature ([B.6](#)).
- Example 6: Offset surface profile specification for a united feature ([B.7](#)).
- Example 7: Combined surface profile specification for a set of features ([B.8](#)).
- Example 8: Surface profile specification for compound feature completely constrained by datums ([B.9](#)).
- Example 9: Combination of a fixed and an off-set specification ([B.10](#)).
- Example 10: Unequally disposed surface profile specification constrained by datums ([B.11](#)).
- Example 11: Surface profile specification for compound feature partially constrained by datums ([B.12](#)).
- Example 12: Surface profile specification for two independent features partially constrained by datums ([B.13](#)).
- Example 13: Line profile specification for a single feature ([B.14](#)).
- Example 14: Line profile specification for a compound derived feature ([B.15](#)).
- Example 15: Surface profile specification for a compound derived feature ([B.16](#)).
- Example 16: Surface profile specification for a complex compound feature ([B.17](#)).

NOTE Not all TEDs are necessary for the interpretation of the specification indicated in each example.

## B.2 Example 1: Surface profile specification for a single feature

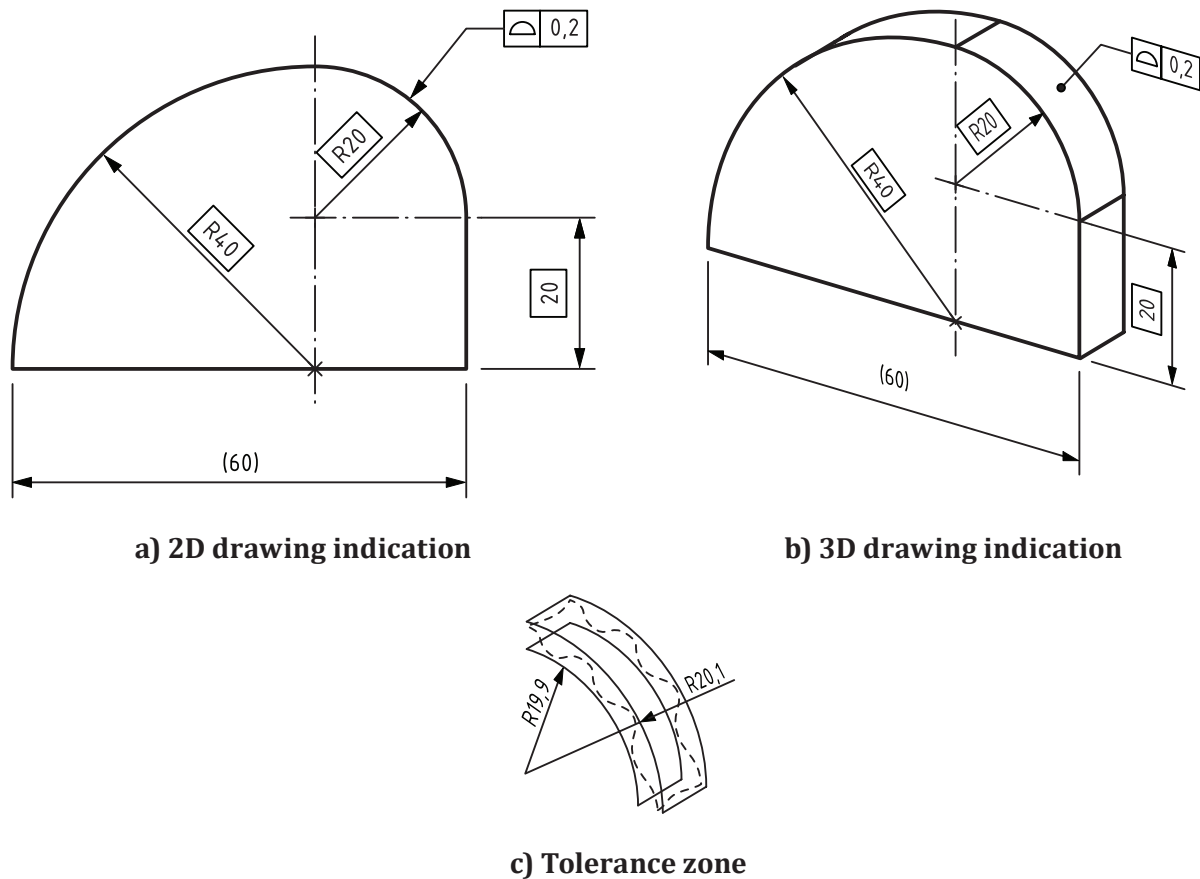

Figure B.1 — Surface profile specification for a single feature

The drawing indications in [Figure B.1](#) a) and b) shall be interpreted as follows:

- According to the feature principle, the specification applies to one complete feature, i.e. the feature identified by the leader line, which is a feature that forms a 90° section of a cylinder with a nominal radius of 20.
- According to rule A, the TEF shall be defined with theoretically exact dimensions. In this case, the tolerated feature is defined as part of a cylinder with a radius of 20.
- According to rule B, the tolerated feature is a surface and according to the indication rules given in ISO 1101:2017, Clause 6, the tolerated feature is an integral surface.
- According to rule C, the tolerance zone is limited by two equidistant surfaces enveloping spheres with a diameter equal to the tolerance value, the centres of which are situated on the TEF. This results in the tolerance zone limits being 90° sections of coaxial cylinders with radius 19,9 and 20,1, respectively.
- Because the specification does not reference datums, the tolerance zone is not constrained.

NOTE The circumference of the workpiece shown in [Figure B.1](#) a) and b) consists of four features: 1) a horizontal planar feature; 2) a vertical planar feature; 3) a 90° section of a cylinder with a nominal radius of 20; and 4) a 90° section of a cylinder with a nominal radius of 40. Although there is no discontinuity between the two cylindrical features and between one of the cylindrical features and one of the planar features, they are nevertheless four separate features.

### B.3 Example 2: Surface profile specification for compound feature

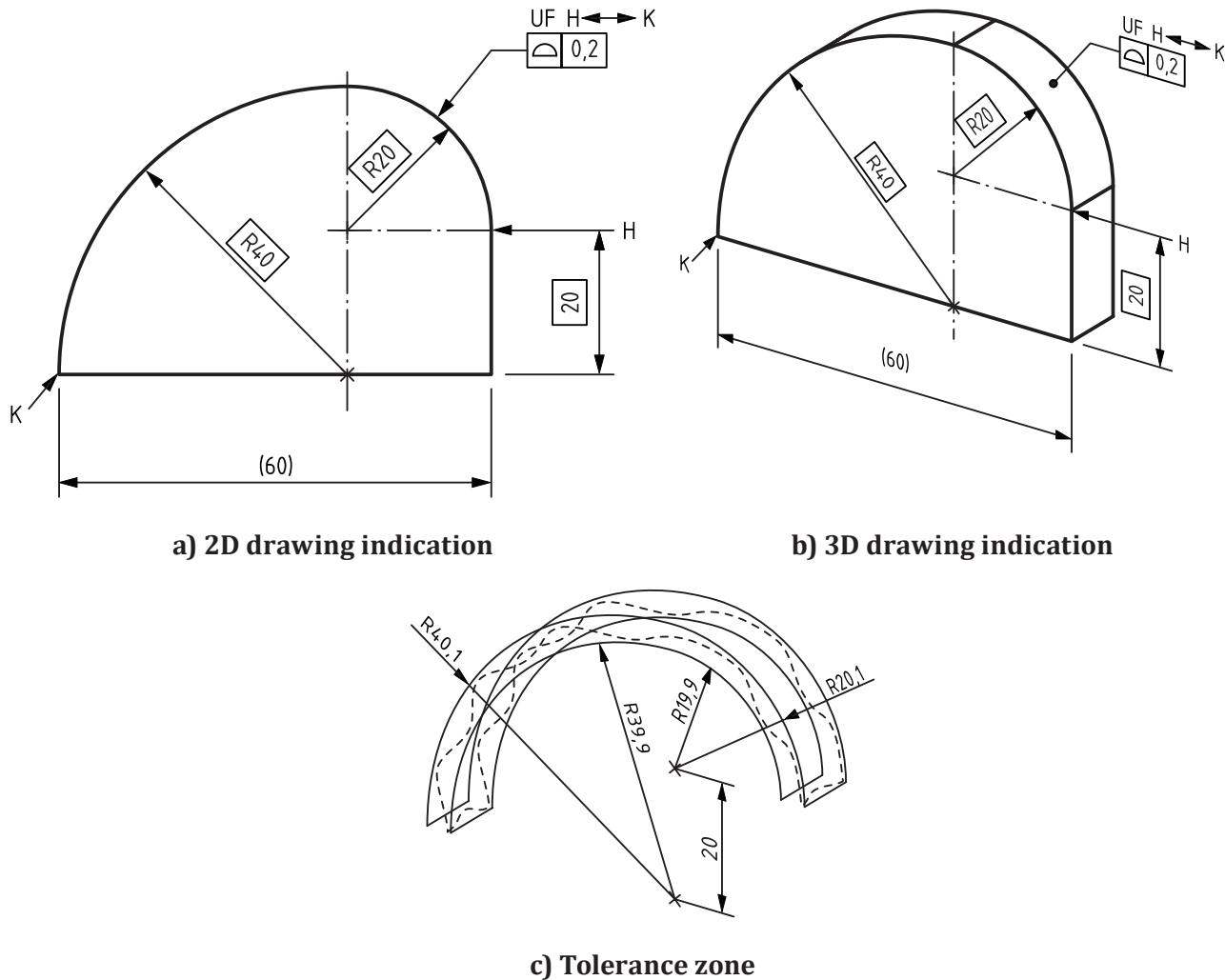

Figure B.2 — Surface profile specification for a compound feature

The drawing indications in [Figure B.2 a\)](#) and [b\)](#) differs from the ones in [Figure B.1 a\)](#) and [b\)](#) in that two specific borderlines are indicated and the “between” modifier symbol is used. The indication shall be interpreted as follows:

- According to rule D, because the “between” symbol is used, the specification applies to the features limited by the borders indicated in the “between” symbol and because the UF modifier is used, the features are considered as one compound feature (a united feature).
- According to rule A, the TEF shall be defined with theoretically exact dimensions. In this case, the tolerated feature is defined as part of a cylinder with a radius of 20 and part of a cylinder with a radius of 40, arranged with a centre distance of 20, such that there is no discontinuity between the two parts of the feature.
- According to rule B, the tolerated feature is a surface and according to the indication rules given in ISO 1101:2017, Clause 6, the tolerated feature is an integral surface.
- According to rule C, the tolerance zone is limited by two equidistant surfaces enveloping spheres with a diameter equal to the tolerance value, the centres of which are situated on the TEF. This



results in the tolerance zone limits being compound curved surfaces each consisting of two 90° sections of cylinders with a centre distance of 20 arranged such that there is no discontinuity between the two parts of the surface. The inner surface has radii of 19,9 and 39,9 and the outer surface has radii of 20,1 and 40,1, respectively.

- Because the specification does not reference datums, the tolerance zone is not constrained.

### B.4 Example 3: Surface profile specification for a set of independent features

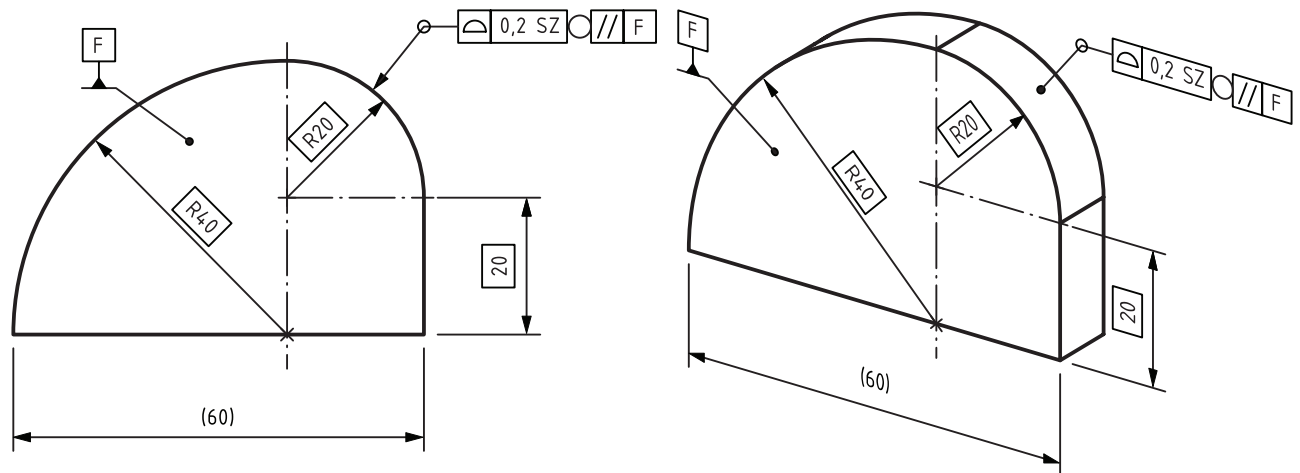

a) 2D drawing indication

b) 3D drawing indication

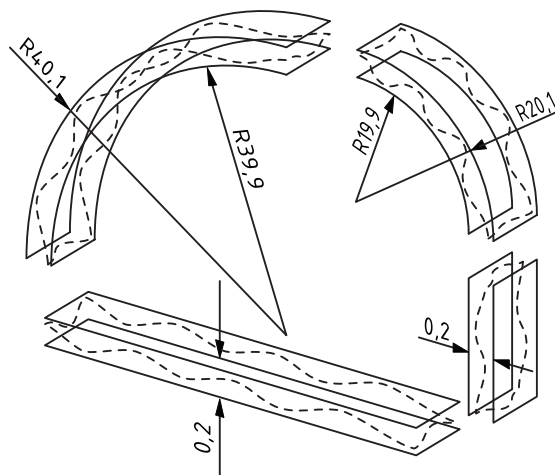

c) Tolerance zone

NOTE 1 TED 20 is not necessary for the interpretation of the specification indicated in the figure.

NOTE 2 The collection plane indicator is defined in ISO 1101:2017, Clause 16.

Figure B.3 — Surface profile specification for a set of independent features

The drawing indications in [Figure B.3](#) a) and b) differ from the ones in [Figure B.1](#) a) and b) in that the “all around” modifier is used. The indication shall be interpreted as follows:

- According to rule D, because the “all around” symbol is used, the specification applies to a set of features that make up the periphery of the workpiece when seen in a plane parallel to datum F as indicated by the collection plane indicator. The features are considered independent, i.e. the tolerance zones are not related to each other. The meaning would have been the same, if four leader lines had been used to identify the four features. The “all around” symbol is a shorthand to identify the features that make up the periphery. To avoid ambiguity, the “all around” symbol is combined with the SZ specification element to indicate that the features are independent.
- According to rule A, the TEF shall be defined with theoretically exact dimensions. In this case, the toleranced features are defined as a part of a cylinder with a radius of 20, a part of a cylinder with a radius of 40, and two planar surfaces.
- According to rule B, the toleranced features are surfaces and according to the indication rules given in ISO 1101:2017, Clause 6, the toleranced features are integral surfaces.
- According to rule C, the tolerance zones are each limited by two equidistant surfaces enveloping spheres with a diameter equal to the tolerance value, the centres of which are situated on the TEF. This results in one tolerance zone’s limits being 90° sections of coaxial cylinders with radius 19,9 and 20,1, respectively, one tolerance zone’s limits being 90° sections of coaxial cylinders with radius 39,9 and 40,1, respectively, and two tolerance zones’ limits being planes separated by 0,2.
- Because the specification does not reference datums, the tolerance zones are not constrained.

### B.5 Example 4: Surface profile specification for a united feature

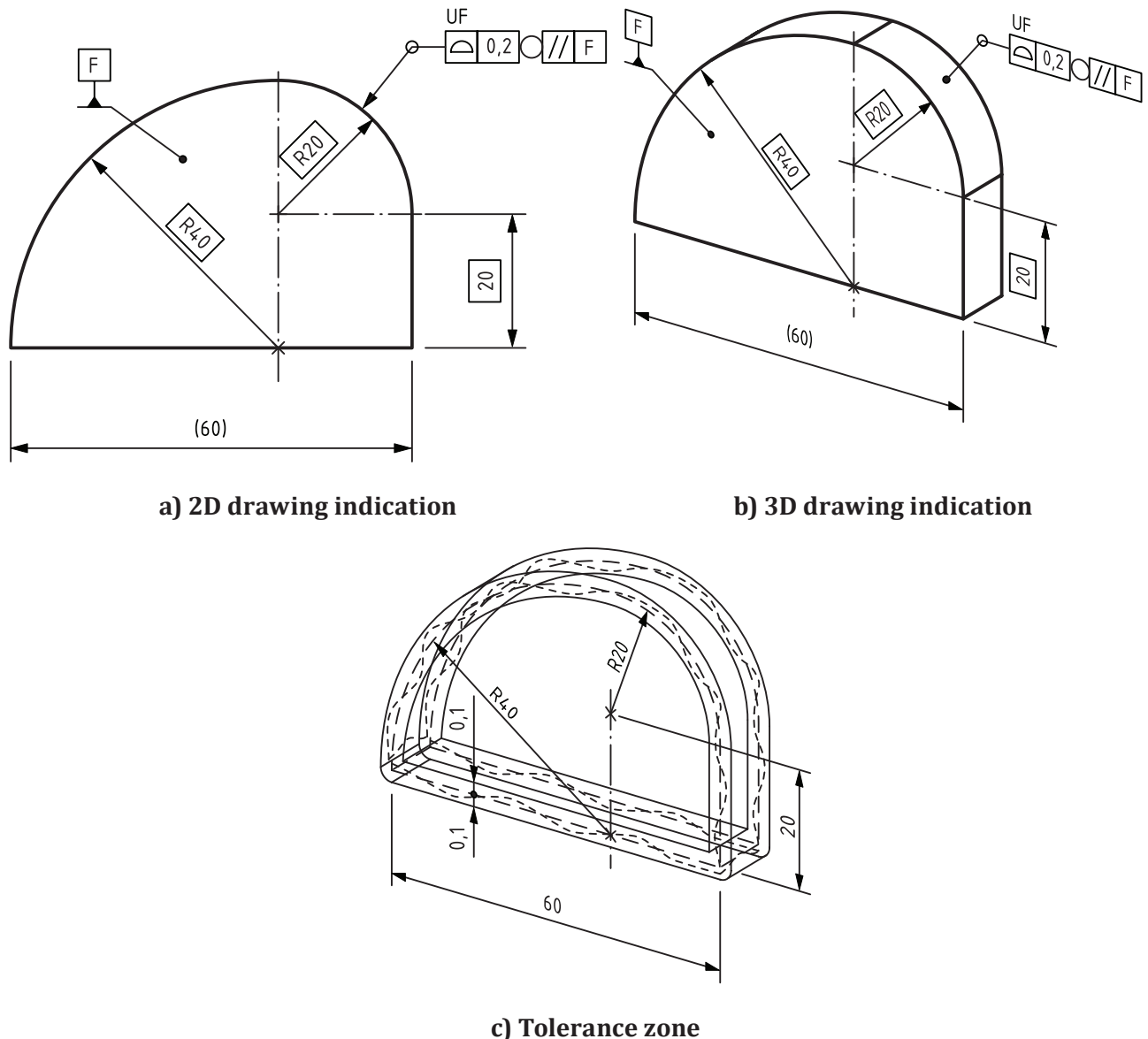

**Figure B.4 — Surface profile specification for a united feature**

The drawing indications in [Figure B.4](#) a) and b) differ from the ones in [Figure B.3](#) a) and b) in that the UF modifier is used to indicate that the specification applies to a united feature. The indication shall be interpreted as follows:

- According to rule D, because the “all around” symbol and the UF modifier are used, the specification applies to a united feature built from the features that make up the periphery of the workpiece when seen in a plane parallel to datum F as indicated by the collection plane indicator. The meaning would have been the same, if four leader lines had been used to identify the four features instead of the “all around” symbol.
- According to rule A, the TEF shall be defined with theoretically exact dimensions. In this case, the tolerated feature is a compound feature, defined as a part of a cylinder with a radius of 20, a part

of a cylinder with a radius of 40, and two planar surfaces in a specific relationship to each other, defined by TEDs.

- According to rule B, the tolerated feature is a surface and according to the indication rules given in ISO 1101:2017, Clause 6, the tolerated feature is an integral surface.
- According to rule C, the tolerance zone is limited by two equidistant surfaces enveloping spheres with a diameter equal to the tolerance value, the centres of which are situated on the TEF.
- Because the specification does not reference datums, the tolerance zone is not constrained.

NOTE 1 Because the periphery is considered one feature, the spheres that define the limits of the tolerance zone are rolled across the discontinuities in the feature and create round corners in the tolerance zone on the outside of the discontinuities.

NOTE 2 The fact that the specification applies to a united feature built from the features that make up the periphery of the workpiece, may be available by query of a CAD model and not otherwise be visible in the CAD system.

### B.6 Example 5: Unequally disposed surface profile specification for a united feature

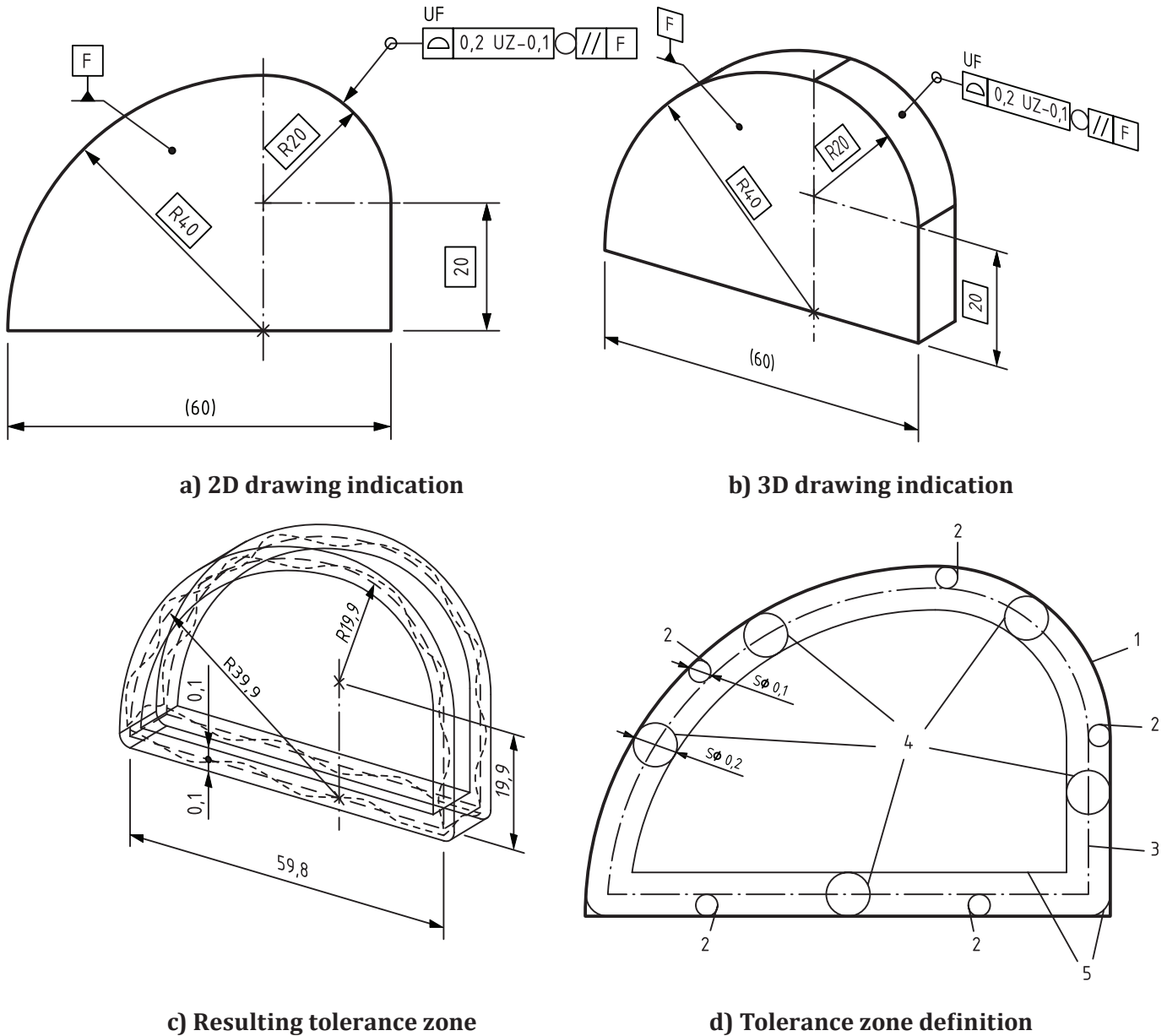

#### Key

- 1 TEF
- 2 representatives of the infinite set of spheres of diameter 0,1 rolling on the inside of the TEF, defining the geometry that is the median surface of the unequally disposed tolerance zone
- 3 off-set geometry
- 4 representatives of the infinite set of spheres of diameter 0,2 centred on the median surface, defining the unequally disposed tolerance zone limits
- 5 unequally disposed tolerance zone limits; note that the tolerance zone has rounded corners

Figure B.5 — Unequally disposed surface profile specification for a united feature

The drawing indications in [Figure B.5](#) a) and b) differ from the ones in [Figure B.4](#) a) and b) in that the UZ modifier is used to indicate that the tolerance zone is moved 0,1 into the material. The indication shall be interpreted as follows:

- According to rule D, because the “all around” symbol and the UF modifier are used, the specification applies to a united feature built from the features that make up the periphery of the workpiece when seen in a plane parallel to datum F, as indicated by the collection plane indicator. The meaning would have been the same, if four leader lines had been used to identify the four features instead of the “all around” symbol.
- According to rule A, the TEF shall be defined with theoretically exact dimensions. In this case, the toleranced feature is a compound feature, defined as a part of a cylinder with a radius of 20, a part of a cylinder with a radius of 40, and two planar surfaces in a specific relationship to each other, defined by TEDs.
- According to rule B, the toleranced feature is a surface and according to the indication rules given in ISO 1101:2017, Clause 6, the toleranced feature is an integral surface.
- According to rule E, because the UZ-0,1 modifier is used, the tolerance zone is unequally disposed around the TEF. An equidistant surface enveloping spheres with a diameter of 0,1 placed on the material side of the TEF, because the value is negative, defines the offset nominal geometry.
- According to rule C, the tolerance zone is limited by two equidistant surfaces enveloping spheres with a diameter equal to the tolerance value, the centres of which are situated on the offset nominal geometry.
- Because the specification does not reference datums, the tolerance zones are not constrained.

NOTE In this particular case, the effect of the unequally disposed tolerance zone with a negative offset equal to half the tolerance value is to move the tolerance zone inside the TEF, so in most areas, the outer specification limit coincides with the TEF. However, in the corners, due to the round corners of the tolerance zone, the outer limit of the tolerance zone does not go all the way out to the TEF.

**B.7 Example 6: Offset surface profile specification for a united feature**

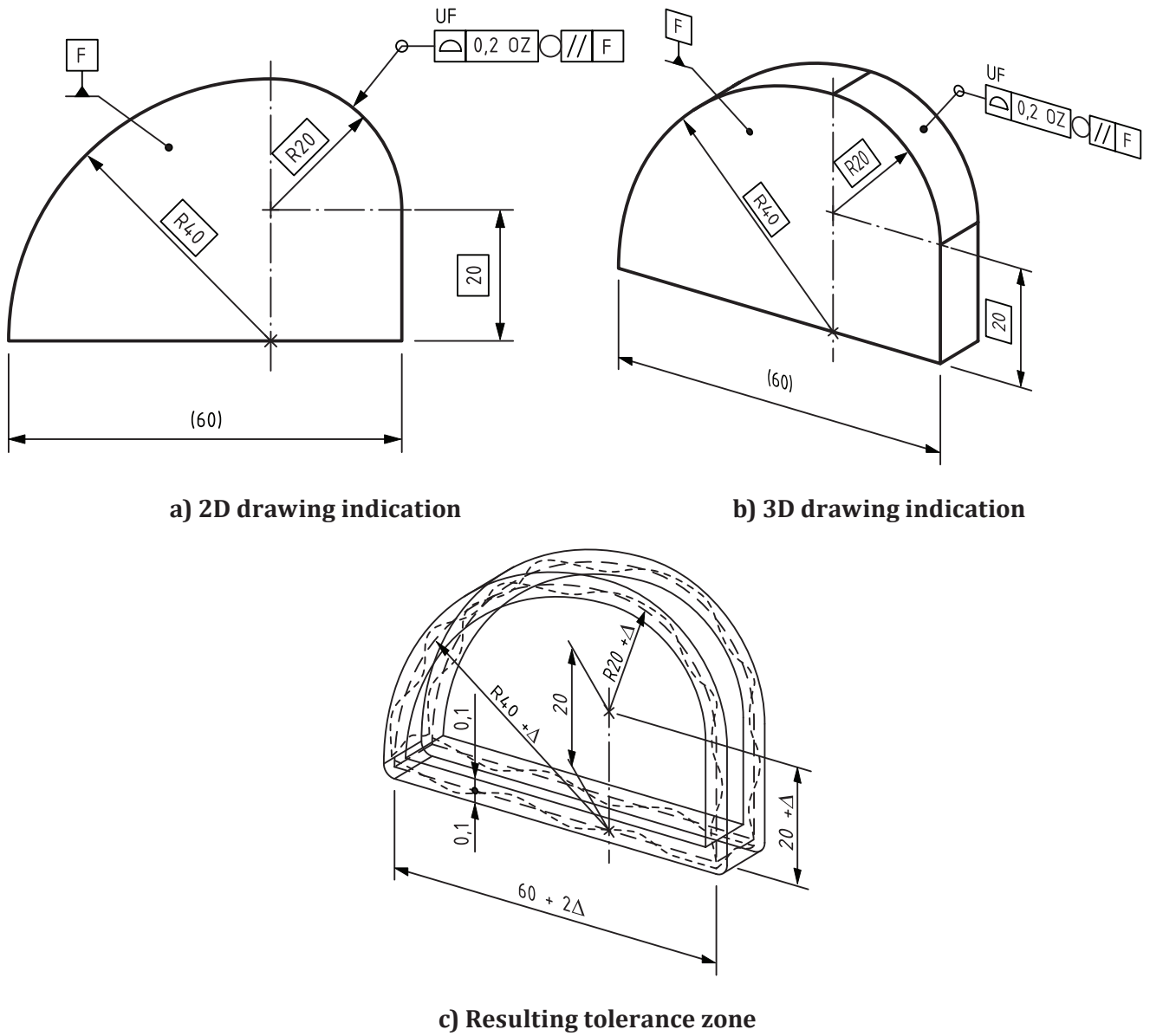

**Figure B.6 — Offset surface profile specification for a united feature**

NOTE See [Figure B.9 c\)](#) for the formal definition of the tolerance zone.

The drawing indications in [Figure B.6 a\)](#) and [b\)](#) differ from the ones in [Figure B.4 a\)](#) and [b\)](#) in that the OZ modifier is used to indicate that an unspecified, but consistent, offset is allowed for the tolerance zone. The indication shall be interpreted as follows:

- According to rule D, because the “all around” symbol and the UF modifier are used, the specification applies to a united feature built from the features that make up the periphery of the workpiece when seen in a plane parallel to datum F, as indicated by the collection plane indicator. The meaning would have been the same, if four leader lines had been used to identify the four features instead of the “all around” symbol.
- According to rule A, the TEF shall be defined with theoretically exact dimensions. In this case, the toleranced feature is a compound feature, defined as a part of a cylinder with a radius of 20, a part of a cylinder with a radius of 40, and two planar surfaces in a specific relationship to each other, defined by TEDs.
- According to rule B, the toleranced feature is a surface and according to the indication rules given in ISO 1101:2017, Clause 6, the toleranced feature is an integral surface.
- According to rule F, because the OZ modifier is used, the tolerance zone is allowed an unspecified, but consistent, offset from the TEF, see ISO 1101:2017, 8.2.2.1.4.1. The offset is indicated as  $\Delta$  in [Figure B.6 c\)](#).
- According to rule C, the tolerance zone is limited by two equidistant surfaces enveloping spheres with a diameter equal to the tolerance value, the centres of which are situated on the offset nominal geometry.
- Because the specification does not reference datums, the tolerance zones are not constrained.

NOTE 1 If  $\Delta$  is negative, the offset nominal geometry will have sharp corners, as shown in [Figure B.6 c\)](#), but if  $\Delta$  is positive, the corners will be rounded with a radius equal to  $\Delta$ .

NOTE 2 Because there are no bounds on  $\Delta$ , a specification with the OZ modifier is usually combined with a specification with a larger tolerance value without the OZ modifier. That way the offset tolerance zone controls the shape of the toleranced feature within the larger, unmodified tolerance zone, see [Figure B.9 c\)](#).



**B.8 Example 7: Combined surface profile specification for a set of features**

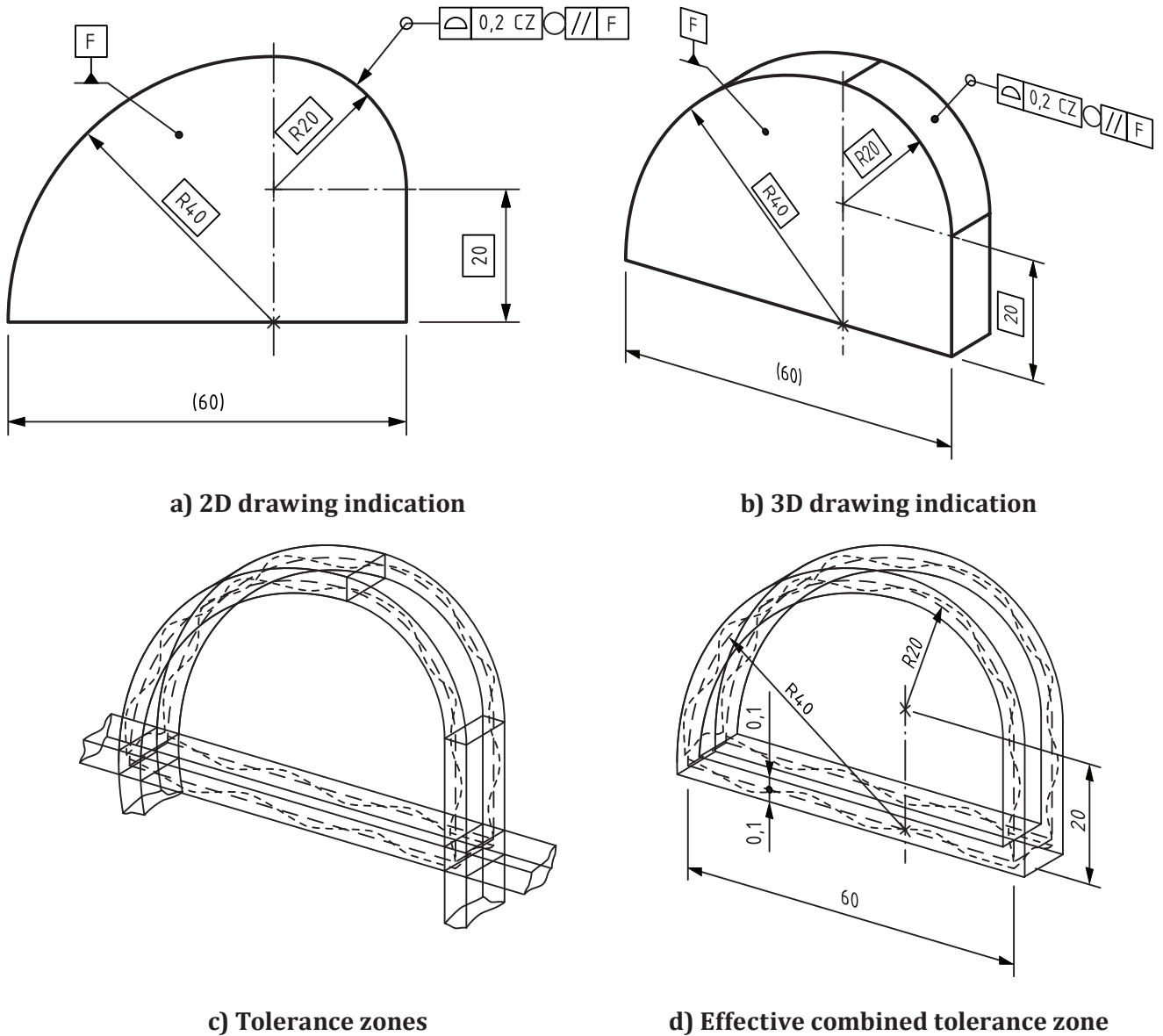

**Figure B.7 — Combined surface profile specification for a set of features**

The drawing indications in [Figure B.7 a\)](#) and [b\)](#) differ from the ones in [Figure B.4 a\)](#) and [b\)](#) in that the CZ modifier is used instead of the UF modifier to indicate that the specification is a combined tolerance zone that applies to a set of features. The indication shall be interpreted as follows:

- According to rule D, because the “all around” symbol is used, the specification applies to a set of features that make up the periphery of the workpiece when seen in a plane parallel to datum F, as indicated by the collection plane indicator. The meaning would have been the same, if four leader lines had been used to identify the four features instead of the “all around” symbol.
- According to rule A, the TEF shall be defined with theoretically exact dimensions. In this case, the toleranced features are a set of four features, defined as a part of a cylinder with a radius of 20, a part of a cylinder with a radius of 40, and two planar surfaces in a specific relationship to each other, defined by TEDs.
- According to rule B, the toleranced features are surfaces and according to the indication rules given in ISO 1101:2017, Clause 6, the toleranced features are integral surfaces.
- According to rule C, each tolerance zone is limited by two equidistant surfaces enveloping spheres with a diameter equal to the tolerance value, the centres of which are situated on the TEF.
- According to rule D, because the CZ, combined zone, modifier is used; the tolerance zones for the four features are combined into one zone. [Figure B.7 c\)](#) show the four zones and how the zones on each side of a corner in principle continue past the corner. Since the features should satisfy all the zones, the resulting combined zone has sharp outside corners, as shown in [Figure B.7 d\)](#). This is the only practical difference from [Figure B.4 c\)](#).
- Because the specification does not reference datums, the tolerance zones are not constrained.

NOTE Conceptually, the UF, united feature, modifier builds one compound feature out of several features and creates one tolerance zone for that compound feature, whereas the CZ, combined zone, modifier considers the features separate, but combines the tolerance zones. The practical difference is small in this case, but may be significant in the case of patterns.

### B.9 Example 8: Surface profile specification for a compound feature completely constrained by datums

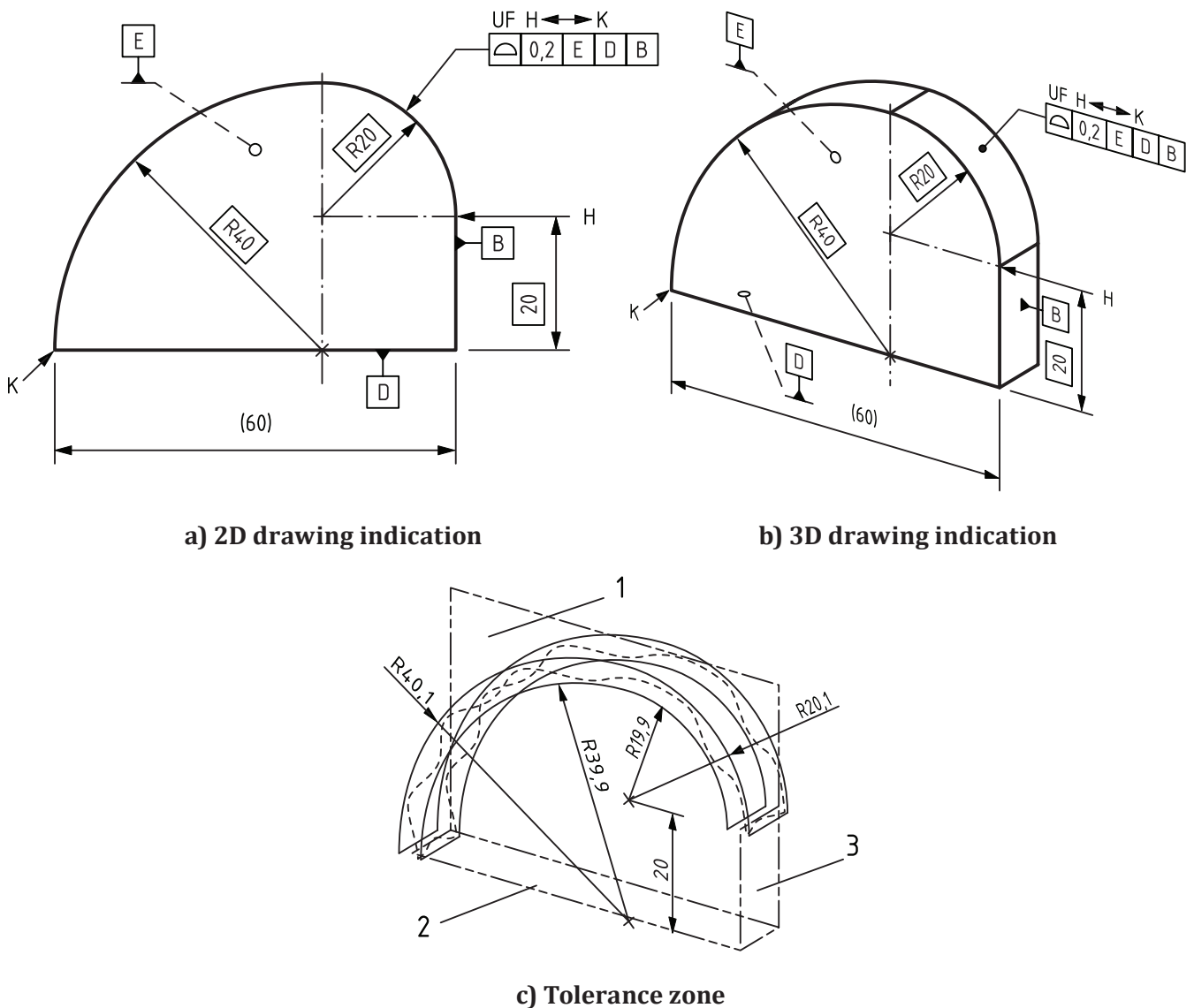

#### Key

- 1 datum E
- 2 datum D
- 3 datum B

**Figure B.8 — Surface profile specification for compound feature completely constrained by datums**

NOTE Because all the non-redundant degrees of freedom for the tolerance zone in [Figure B.8](#) are locked by reference to a datum system, the UF modifier could have been omitted without changing the practical meaning of the specification.

The drawing indications in [Figure B.8](#) a) and b) differ from the ones in [Figure B.2](#) a) and b) in that a complete datum system is referenced in the tolerance indicator. The indication shall be interpreted as follows:

- According to rule D, because the “between” symbol is used, the specification applies to a compound feature limited by the borders indicated in the “between” symbol. Because the UF modifier is indicated, the compound feature is considered as one feature.
- According to rule A, the TEF shall be defined with theoretically exact dimensions. In this case, the tolerated feature is defined as part of a cylinder with a radius of 20 and part of a cylinder with a radius of 40, arranged with a centre distance of 20, such that there is no discontinuity between the two parts of the feature.
- According to rule B, the tolerated feature is a surface and according to the indication rules given in ISO 1101:2017, Clause 6, the tolerated feature is an integral surface.
- According to rule C, the tolerance zone is limited by two equidistant surfaces enveloping spheres with a diameter equal to the tolerance value, the centres of which are situated on the TEF. This results in the tolerance zone limits being compound curved surfaces each consisting of two 90° sections of cylinders with a centre distance of 20 arranged such that there is no discontinuity between the two parts of the surface. The inner surface has radii of 19,9 and 39,9 and the outer surface has radii of 20,1 and 40,1, respectively.
- Because the specification references a full datum system, the tolerance zone is completely constrained by the datum system and cannot move relative to the datum system. The detailed rules for how the datum system constrains the tolerance zone are given in ISO 5459.

NOTE Because the referenced datums lock all the non-redundant degrees of freedom for the tolerance zone and because there is no angular discontinuity between the two integral features, the resulting constraints would have been the same, if SZ or CZ had been used instead of UF.

**B.10 Example 9: Combination of a fixed and an off-set specification**

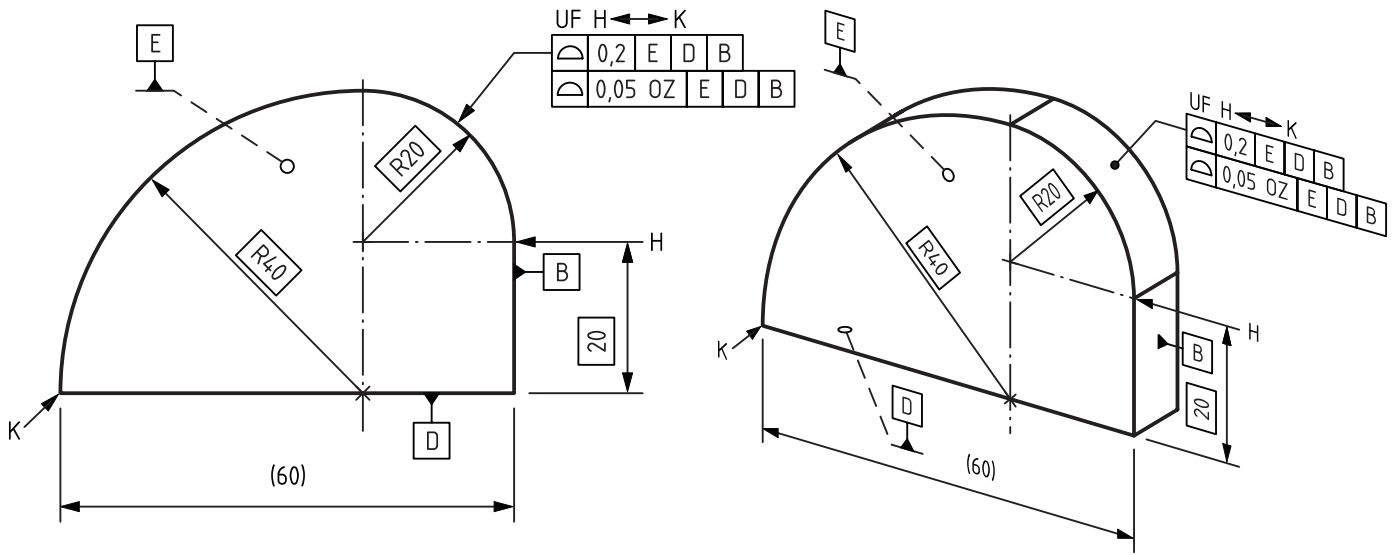

**a) 2D drawing indication**

**b) 3D drawing indication**

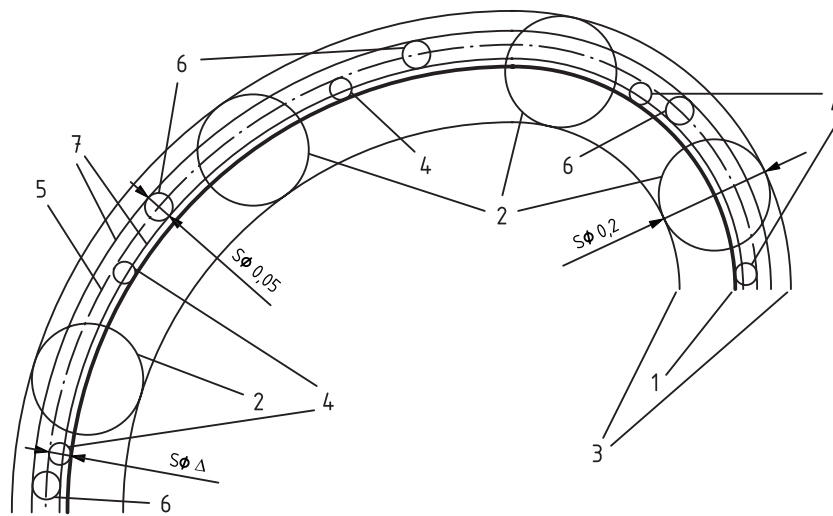

**c) Tolerance zone**

**Key**

- 1 TEF
- 2 representatives of the infinite set of spheres of diameter 0,2 centred on the TEF defining the fixed tolerance zone limits
- 3 fixed tolerance zone limits
- 4 representatives of the infinite set of spheres of non-predetermined but consistent diameter defining the off-set geometry that is the median surface of the off-set tolerance zone
- 5 off-set geometry
- 6 representatives of the infinite set of spheres of diameter 0,05 centred on the off-set median surface defining the off-set tolerance zone limits
- 7 off-set tolerance zone limits

**Figure B.9 — Combination of a fixed and an off-set specification**

NOTE Because all the non-redundant degrees of freedom for the tolerance zone defined by the upper tolerance indicator in [Figure B.9 a\)](#) and [Figure B.9 b\)](#) are locked by reference to a datum system, the UF modifier could have been omitted without changing the practical meaning of the specification. This is not the case for the tolerance zone defined by the lower tolerance indicator. In this case, the UF modifier is necessary to synchronize the offset of the two parts of the tolerance zone.

The drawing indications in [Figure B.9 a\)](#) and [b\)](#) define a combination of a fixed tolerance zone with a larger tolerance values and an off-set tolerance zone with a smaller tolerance value. The fixed tolerance zone is identical to the one shown in [Figure B.8](#). The off-set tolerance zone is similar to the one shown in [Figure B.6](#), except it only applies between lines H and K. The off-set tolerance zone is off-set by a non-predetermined amount, either into the material or out of the material compared to the TEF. The combination of the two specifications controls the shape of the tolerated feature within the off-set tolerance zone, which can adapt to the tolerated feature, as long as the off-set tolerance zone remains within the fixed tolerance zone.

The rules for the fixed tolerance zone are the same as for [Figure B.8](#). The rules for the off-set tolerance zone are similar to those for [Figure B.6](#).

### B.11 Example 10: Unequally disposed surface profile specification constrained by datums

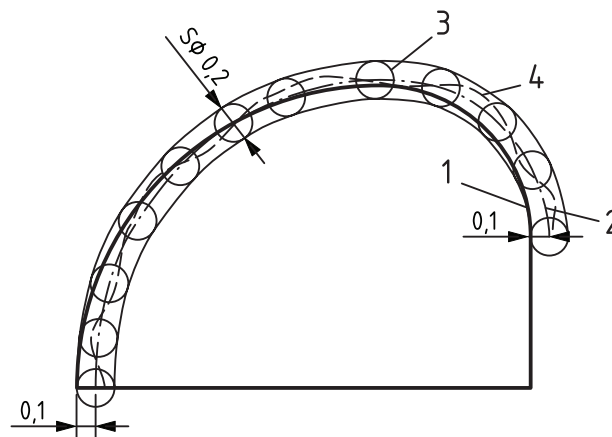
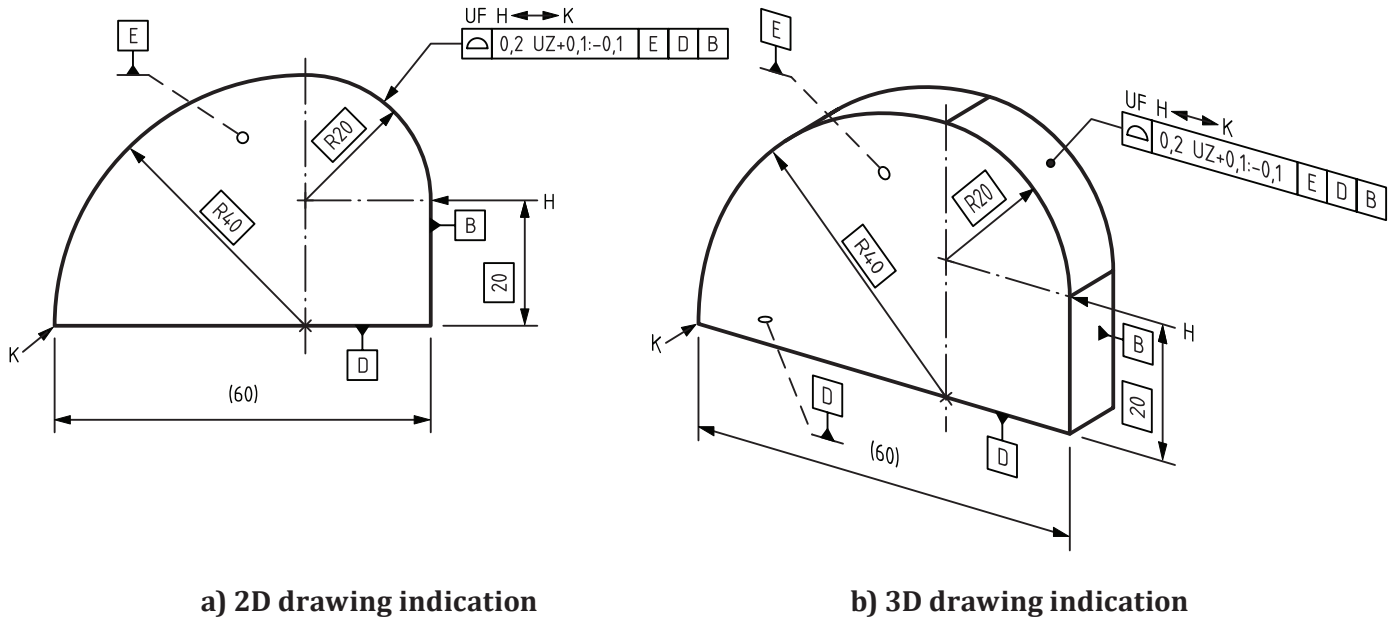

c) Tolerance zone

#### Key

- 1 TEF
- 2 median surface of tolerance zone; starts 0,1 outside the TEF at H and ends 0,1 inside the TEF at K
- 3 spheres of diameter 0,2 centred on the median surface of the tolerance zone, which defines the tolerance zone limits
- 4 real toleranced feature

**Figure B.10 — Unequally disposed surface profile specification with variable displacement, constrained by datums**

NOTE Because all the non-redundant degrees of freedom for the tolerance zone in [Figure B.10](#) are locked by reference to a datum system, the UF modifier could have been omitted without changing the practical meaning of the specification.

The drawing indications in [Figure B.10](#) a) and b) differ from the ones in [Figure B.8](#) a) and b) in that a UZ modifier is used to indicate an unequally disposed tolerance zone. It differs from the unequally disposed tolerance zone indicated in [Figure B.5](#) a) and b) in that it is not unequally disposed by a constant amount. The indication shall be interpreted as follows:

- According to rule D, because the “between” symbol is used, the specification applies to a compound feature limited by the borders indicated in the “between” symbol. Because the UF modifier is indicated, the compound feature is considered as one feature.
- According to rule A, the TEF shall be defined with theoretically exact dimensions. In this case, the tolerated feature is defined as part of a cylinder with a radius of 20 and part of a cylinder with a radius of 40, arranged with a centre distance of 20, such that there is no discontinuity between the two parts of the feature.
- According to rule B, the tolerated feature is a surface and according to the indication rules given in ISO 1101:2017, Clause 6, the tolerated feature is an integral surface.
- According to rule E, because the UZ+0,1:-0,1 modifier is used, the tolerance zone is unequally disposed around the TEF. The +0,1 value (outside the material) corresponds to location H, because they are both listed first and the -0,1 value (inside the material) corresponds to location K, because they are both listed last. The displacement of the median surface of the tolerance zone varies linearly along the curvilinear length of the tolerated feature.
- According to rule C, the tolerance zone is limited by two equidistant surfaces enveloping spheres with a diameter equal to the tolerance value, the centres of which are situated on the median surface of the tolerance zone.
- Because the specification references a full datum system, the tolerance zone is completely constrained by the datum system and cannot move relative to the datum system. The detailed rules for how the datum system constrains the tolerance zone are given in ISO 5459.



### B.12 Example 11: Surface profile specification for a compound feature partially constrained by datums

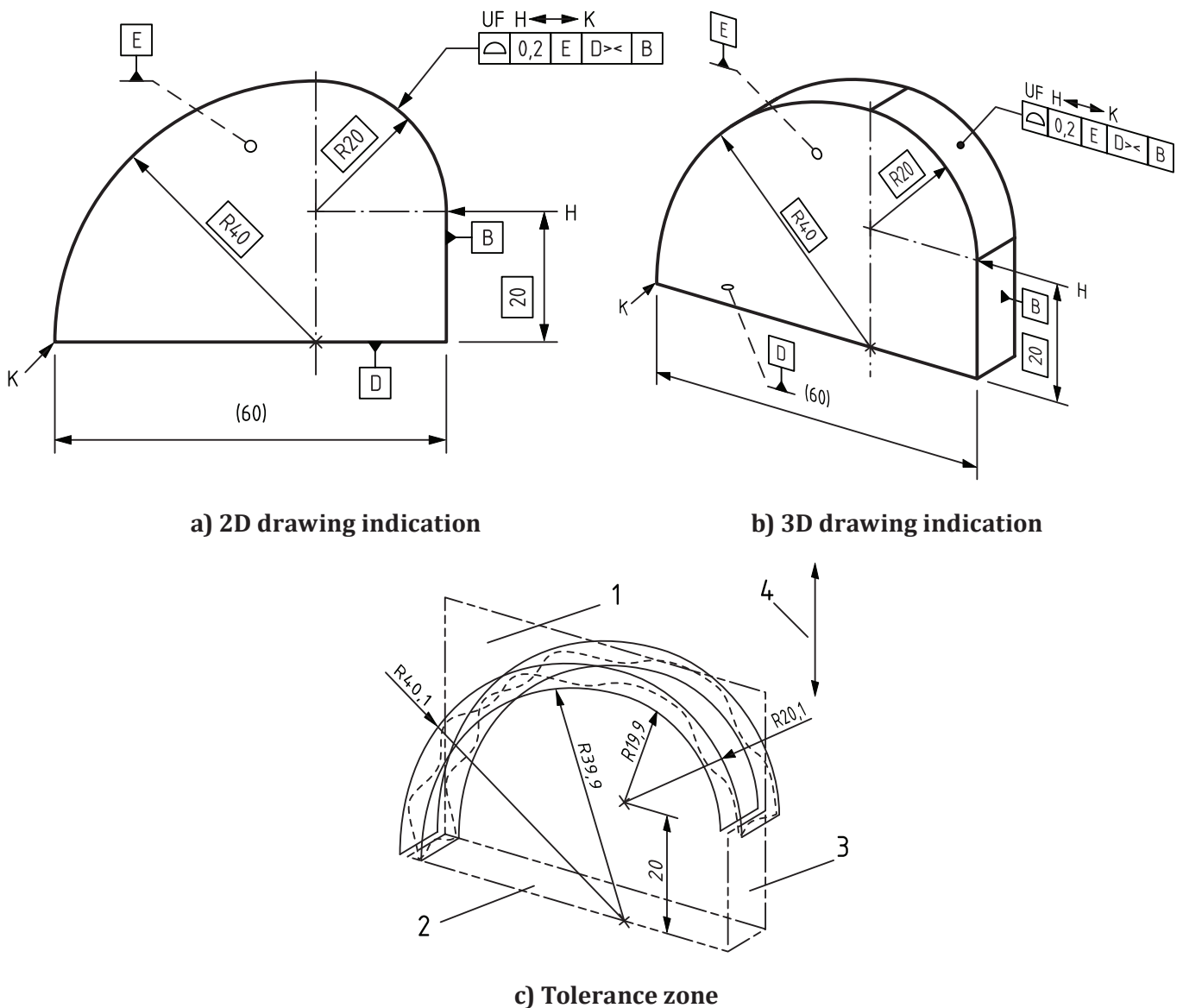

#### Key

- 1 primary datum E
- 2 secondary datum D
- 3 tertiary datum B
- 4 direction of unconstrained motion for the tolerance zone

**Figure B.11 — Surface profile specification for compound feature partially constrained by datums**

The drawing indications in [Figure B.11 a\)](#) and [b\)](#) differ from the ones in [Figure B.8 a\)](#) and [b\)](#) in that the >< “orientation constraint only” modifier is added to datum D. The interpretation differs as follows:

- Because of the >< “orientation constraint only” modifier for datum D, that datum does not constrain translation, allowing the tolerance zone to move in the vertical direction. The detailed rules for how the datum system constrains the tolerance zone are given in ISO 5459.

**B.13 Example 12: Surface profile specification for two independent features partially constrained by datums**

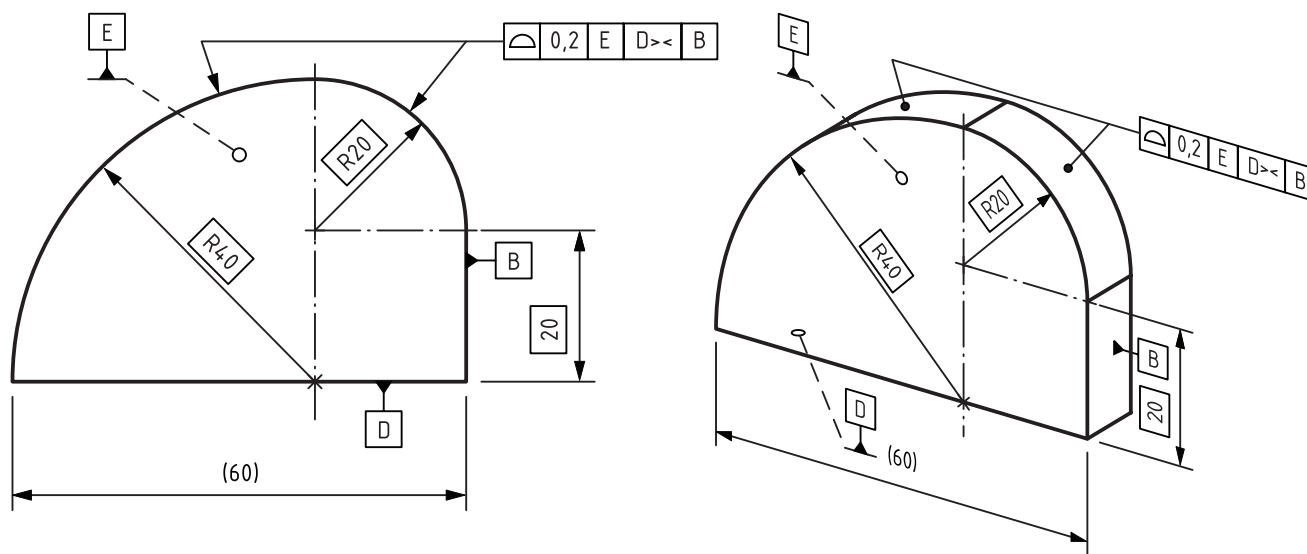

a) 2D drawing indication

b) 3D drawing indication

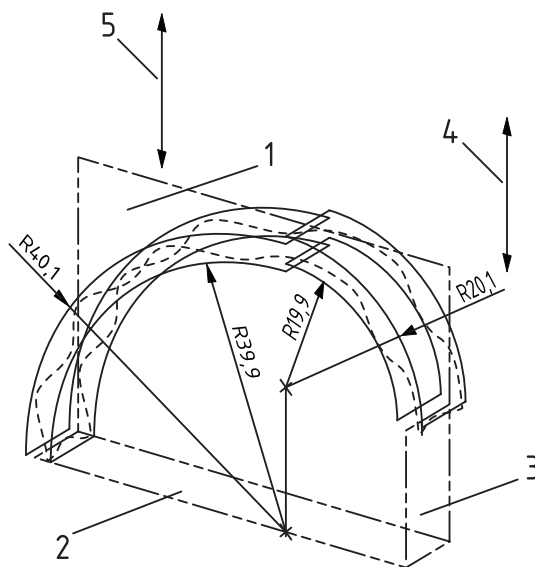

c) Tolerance zone

**Key**

- 1 primary datum E
- 2 secondary datum D
- 3 tertiary datum B
- 4 Direction of unconstrained motion for the R20 tolerance zone
- 5 direction of unconstrained motion for the R40 tolerance zone

NOTE 1 The movements 4 and 5 are independent of each other.

NOTE 2 TED 20 is not necessary for the interpretation of the specification indicated in this figure.

**Figure B.12 — Surface profile specification for two independent features partially constrained by datums**

The drawing indications in [Figure B.12](#) a) and b) differ from the ones in [Figure B.11](#) a) and b) in that the two toleranced features are considered separate features, because there is no indication tying them together. The interpretation differs as follows:

- Because of the two toleranced features are not identified as one feature using the UF modifier and the tolerance zones are not combined using the CZ modifier, the two tolerance zones are independent according to the independency principle, see ISO 8015.
- Because of the >< “orientation constraint only” modifier for datum D, that datum does not constrain translation, allowing the tolerance zones to move in the vertical direction. The detailed rules for how the datum system constrains the tolerance zone are given in ISO 5459.
- Because the two tolerance zones are independent, they can move in the vertical direction independent of each other.

**B.14 Example 13: Line profile specification for a single feature**

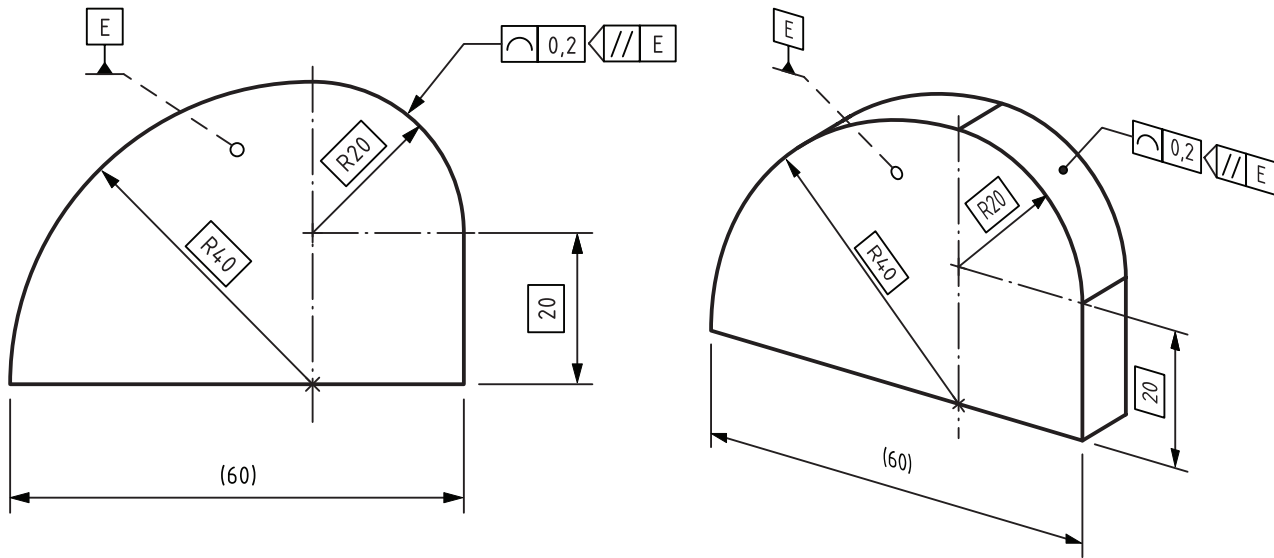

**a) 2D drawing indication**

**b) 3D drawing indication**

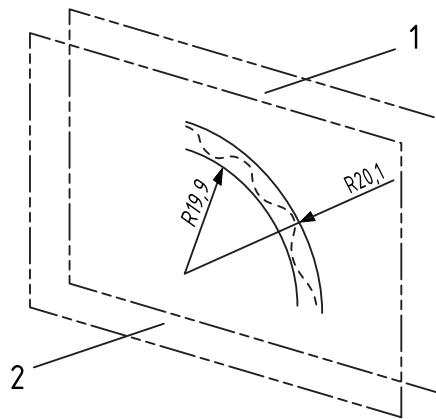

**c) Tolerance zone**

**Key**

- 1 datum E
- 2 intersection plane parallel to datum E

NOTE TEDs 20 and R40 are not necessary for the interpretation of the specification indicated in this figure.

**Figure B.13 — Line profile specification for a single feature**

The drawing indications in [Figure B.13 a\)](#) and [b\)](#) differ from the ones in [Figure B.1 a\)](#) and [b\)](#) in that the line profile symbol is used instead of the surface profile symbol and that an intersection plane indicator is indicated referencing datum E. The drawing indications in [Figure B.13 a\)](#) and [b\)](#) shall be interpreted as follows:

- According to the feature principle, the specification applies to one complete feature, i.e. the feature identified by the leader line, which is a feature that forms a 90° section of a cylinder with a nominal radius of 20.

- According to rule A, the TEF shall be defined with theoretically exact dimensions. In this case, the toleranced feature is defined as part of a cylinder with a radius of 20.
- According to rule B, the toleranced feature is all lines in the identified feature parallel to datum plane E and according to the indication rules given in ISO 1101:2017, Clause 6, the toleranced feature is an integral feature.
- According to rule C, each tolerance zone is limited by two equidistant lines enveloping circles with a diameter equal to the tolerance value, the centres of which are situated on the TEF. This results in the tolerance zone limits being 90° sections of coaxial circles with radius 19,9 and 20,1, respectively.
- Because the tolerance indicator does not reference datums, the tolerance zone is not constrained.

NOTE 1 This specification does not constrain the relationship between the toleranced lines, i.e. the location and orientation in each plane parallel to datum E are not constrained. This is the practical difference between the specifications in [Figure B.1](#) and [B.13](#).

NOTE 2 The specifications in [Figures B.2](#) to [B.12](#) could all be altered to use the line profile symbol instead of the surface profile symbol and their meaning would change similarly to the difference between the specifications in [Figure B.1](#) and [B.13](#). The only exceptions are the specifications in [Figure B.8](#) and [B.10](#). Because the tolerance zones in these cases are completely constrained by datums, the meaning of a surface profile specification and a line profile specification would be the same.

**B.15 Example 14: Line profile specification for a compound derived feature**

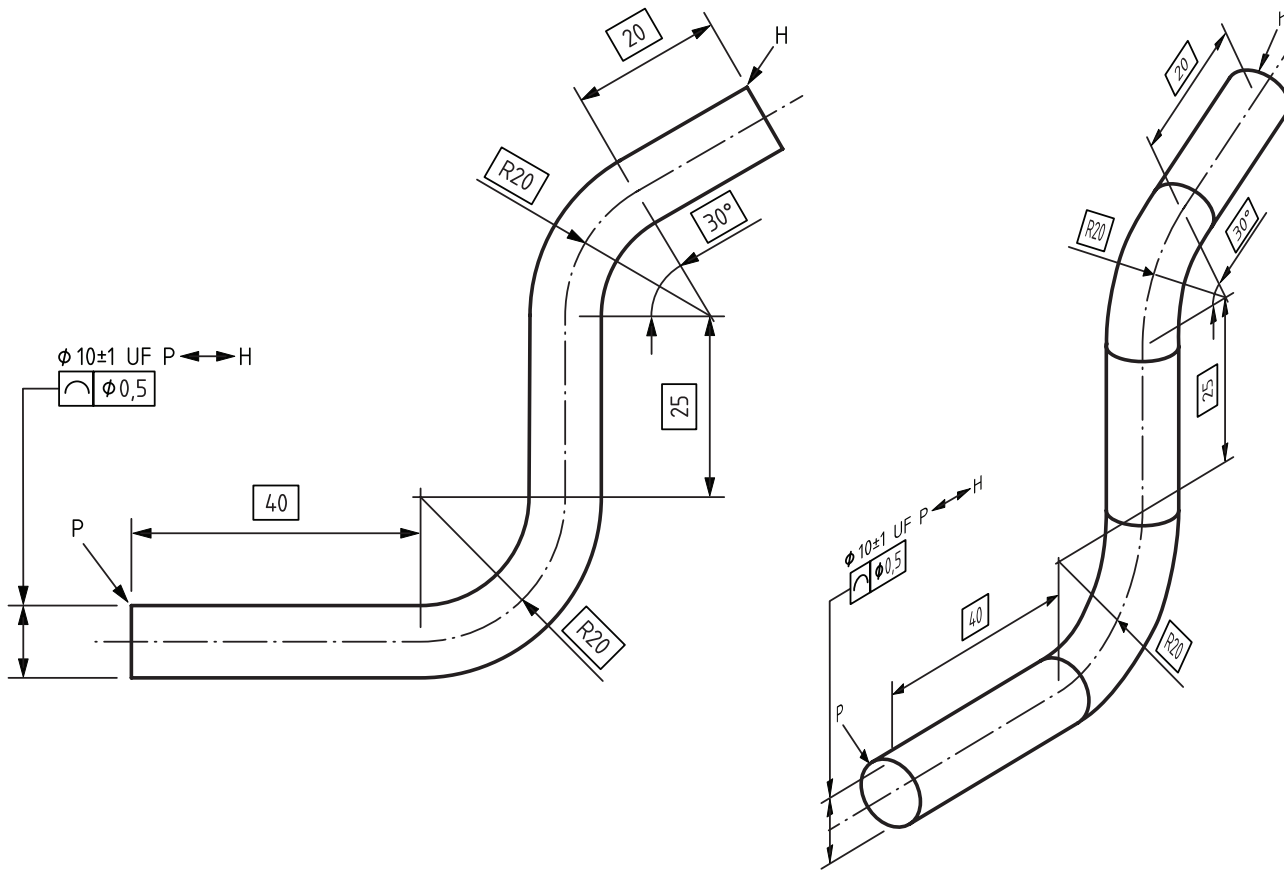

**a) 2D drawing indication**

**b) 3D drawing indication**

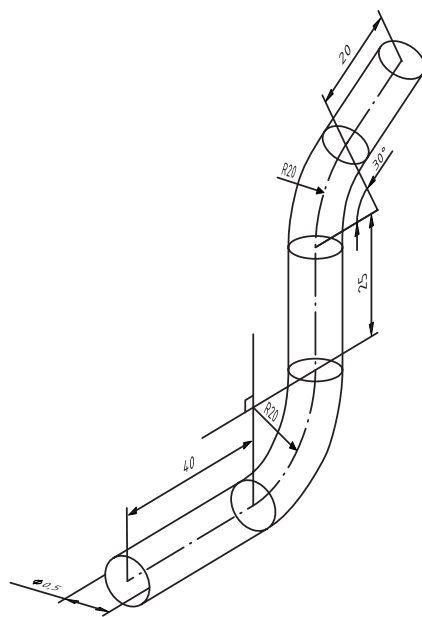

**c) Tolerance zone**

**Figure B.14 — Line profile specification for a compound derived feature**

The drawing indications in [Figure B.14](#) a) and b) shall be interpreted as follows:

- According to rule D, because the “between” symbol and the UF modifier are used, the specification applies to a compound feature limited by the borders indicated in the “between” symbol. The compound feature is considered as one feature.
- According to rule A, the TEF shall be defined with theoretically exact dimensions. In this case, the tolerated feature is defined as a compound line consisting of three straight segments joined by two circular segments of radius 20; one 90° segment and one 30° segment.
- According to rule B, the tolerated feature is a line and according to the indication rules given in ISO 1101:2017, Clause 6, the tolerated feature is a derived line.
- According to rule C, the tolerance zone is limited by a tube enveloping spheres with a diameter equal to the tolerance value, the centres of which are situated on the TEF.
- Because the specification does not reference datums, the tolerance zone is not constrained.

NOTE The meaning would have been the same if the position characteristic symbol had been used instead of the line profile characteristic symbol.

**B.16 Example 15: Surface profile specification for a compound derived feature**

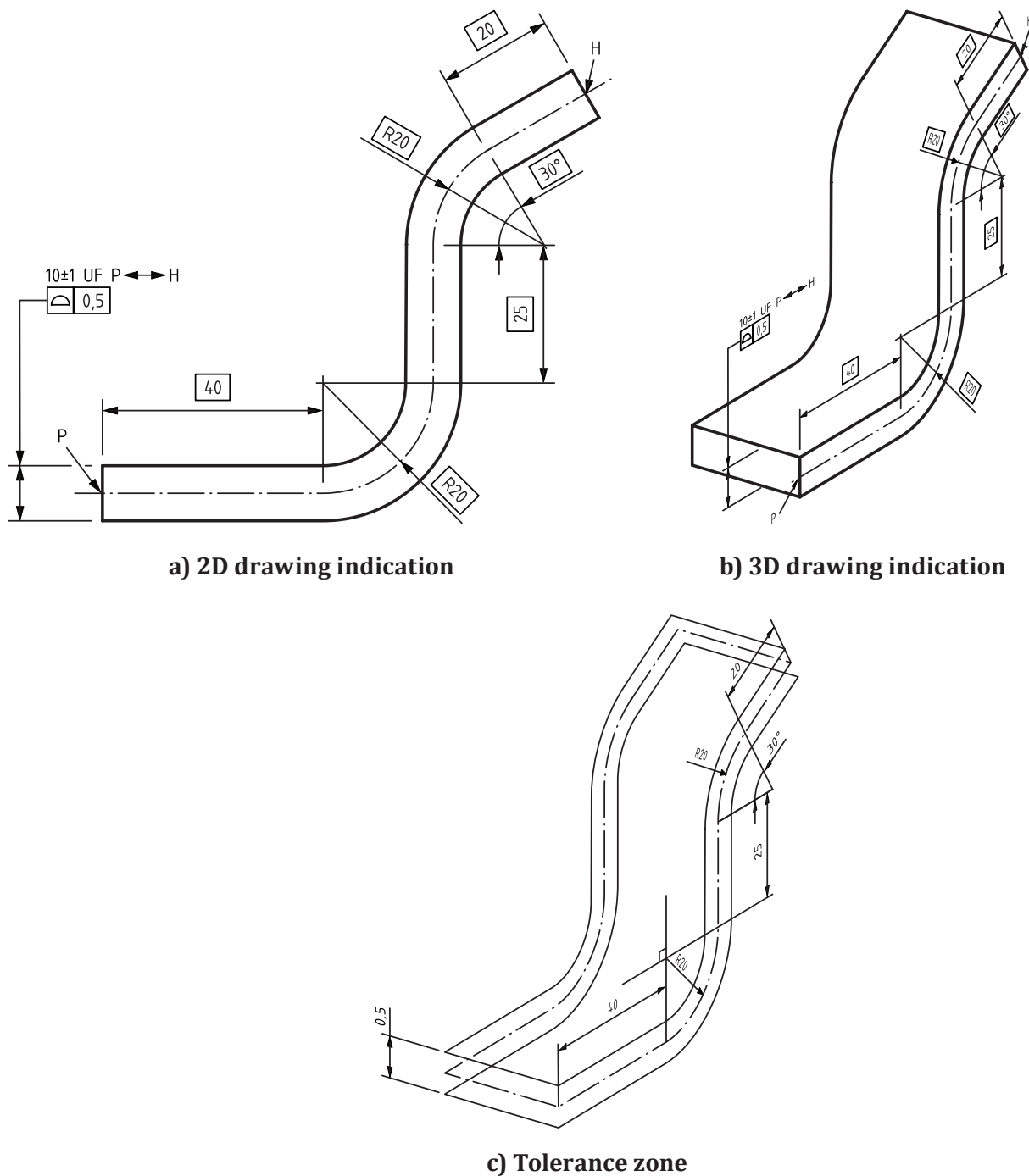

**Figure B.15 — Surface profile specification for a compound derived feature**

The drawing indications in [Figure B.15](#) a) and b) shall be interpreted as follows:

- According to rule D, because the “between” symbol and the UF modifier are used, the specification applies to a compound feature limited by the borders indicated in the “between” symbol. The compound feature is considered as one feature.



- According to rule A, the TEF shall be defined with theoretically exact dimensions. In this case, the tolerated feature is defined as a compound surface consisting of three planar segments joined by two curved segments of radius 20; one 90° segment and one 30° segment.
- According to rule B, the tolerated feature is a surface and according to the indication rules given in ISO 1101:2017, Clause 6, the tolerated feature is a derived surface.
- According to rule C, the tolerance zone is limited by two equidistant surfaces enveloping spheres with a diameter equal to the tolerance value, the centres of which are situated on the TEF.
- Because the specification does not reference datums, the tolerance zone is not constrained.

NOTE The meaning would have been the same if the position symbol had been used.

**B.17 Example 16: Surface profile specification for a complex compound feature**

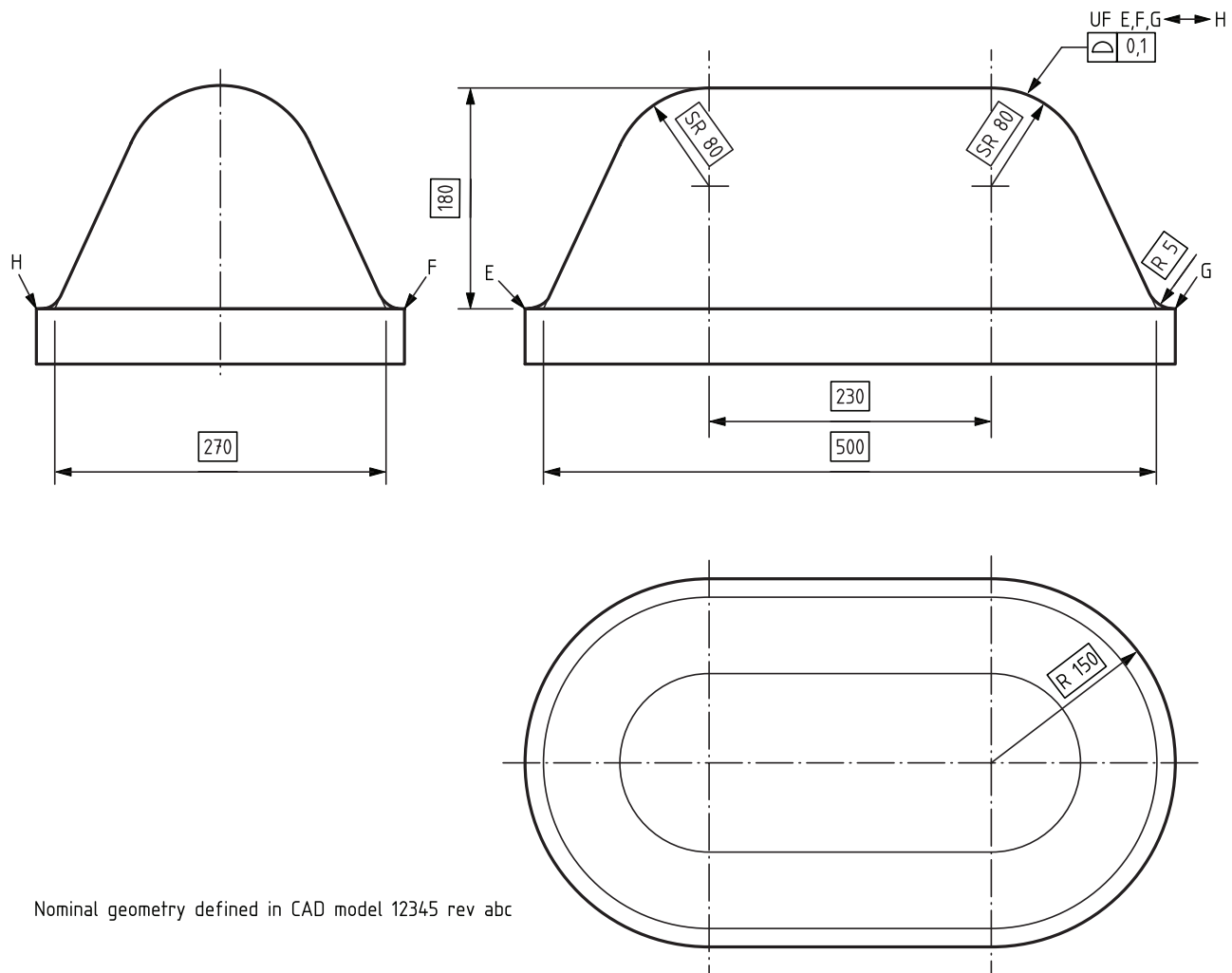

Nominal geometry defined in CAD model 12345 rev abc

**a) Indication on the drawing**

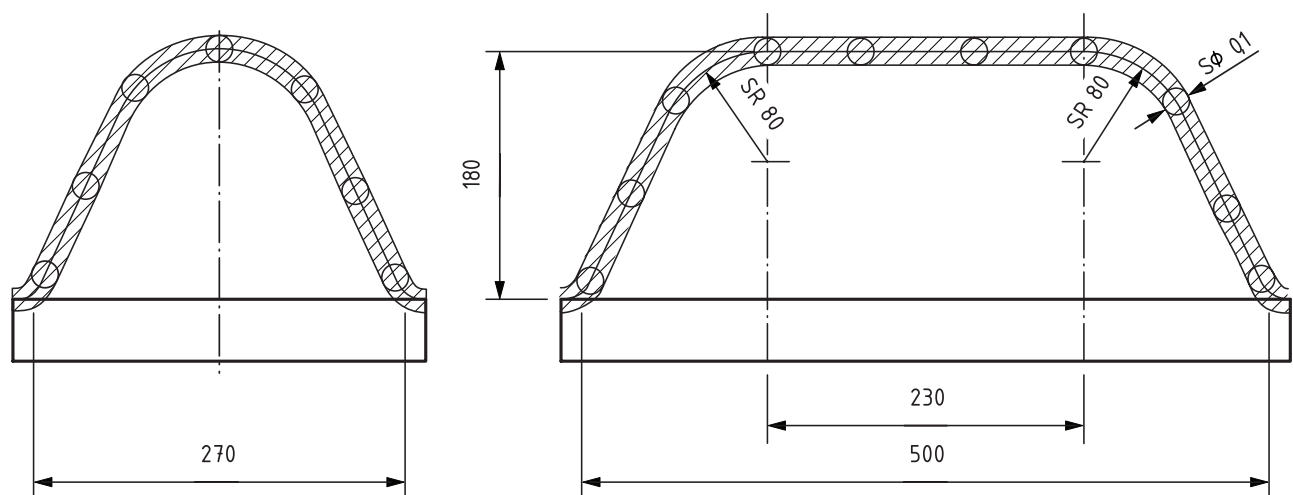

**b) Tolerance zone**

**Figure B.16 — Surface profile specification for a complex compound feature**

The drawing indications in [Figure B.16 a\)](#) shall be interpreted as follows.

- According to rule D, because the “between” symbol and the UF modifier are used, the specification applies to a compound feature limited by the borders indicated in the “between” symbol. The compound feature is considered as one feature.
- According to rule A, the TEF shall be defined with theoretically exact dimensions. In this case, the toleranced feature is defined by reference to a CAD model that complies with ISO 16792.

NOTE Because the TEF is given by reference to a CAD model, the TEDs shown on the drawing are for information only.

- According to rule B, the toleranced feature is a surface and according to the indication rules given in ISO 1101:2017, Clause 6, the toleranced feature is an integral surface.
- According to rule C, the tolerance zone is limited by two equidistant surfaces enveloping spheres with a diameter equal to the tolerance value, the centres of which are situated on the TEF.
- Because the specification does not reference datums, the tolerance zone is not constrained.

## Annex C (informative)

### Former practices

**C.1** This annex describes former practices that have been abandoned and are no longer used. Therefore, they are not an integral part of this document, but should be used for information only.

**C.2** The previous version of this document, ISO 1660:1987, contained a figure similar to [Figure C.1](#). The document did not give a rule, but the figure implied that a profile specification applied “from edge to edge”. This is ambiguous, because there is no definition of what constitutes an edge. In addition, it is contrary to the feature principle defined in ISO 8015:2011, 5.4.

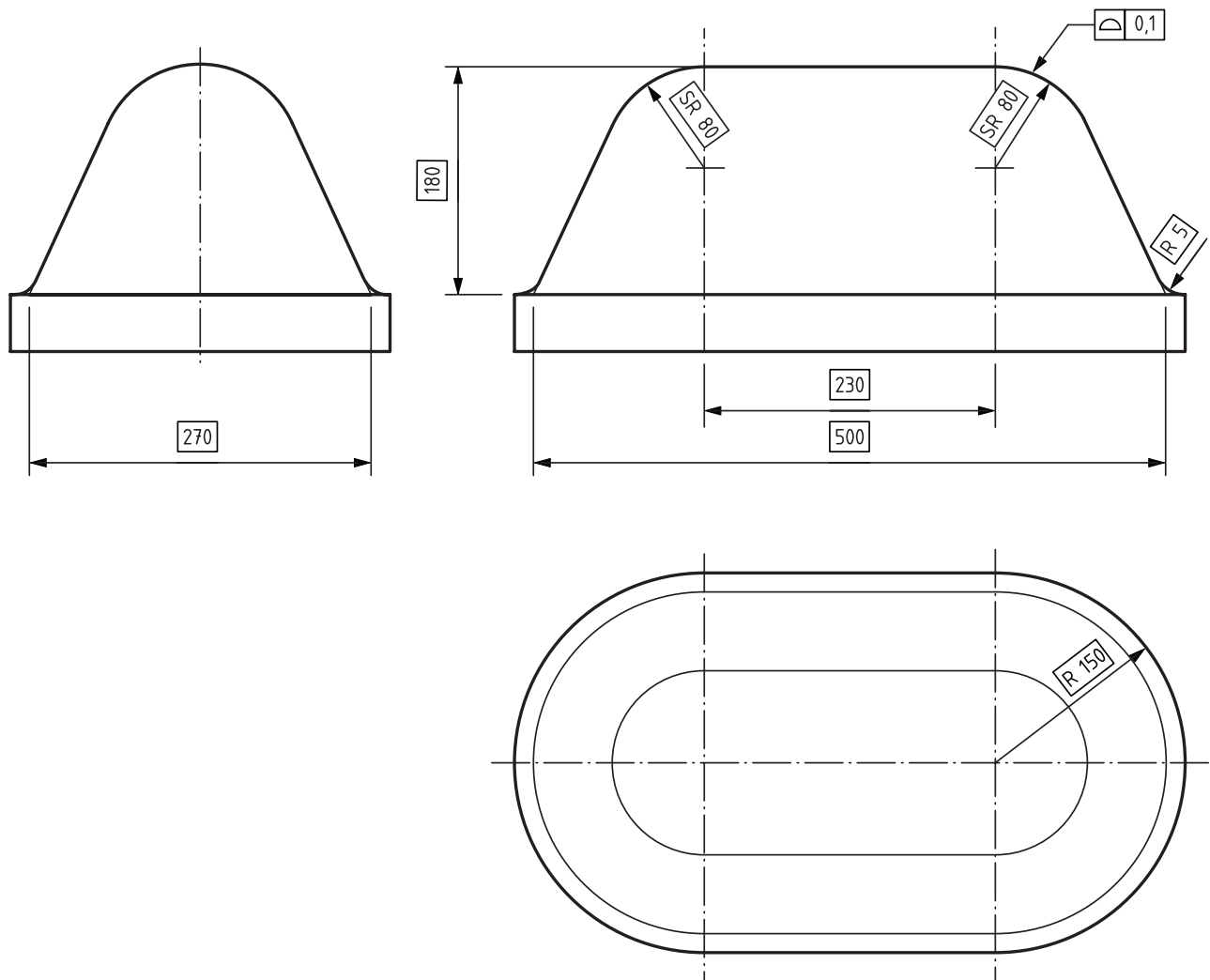

a) Indication on the drawing

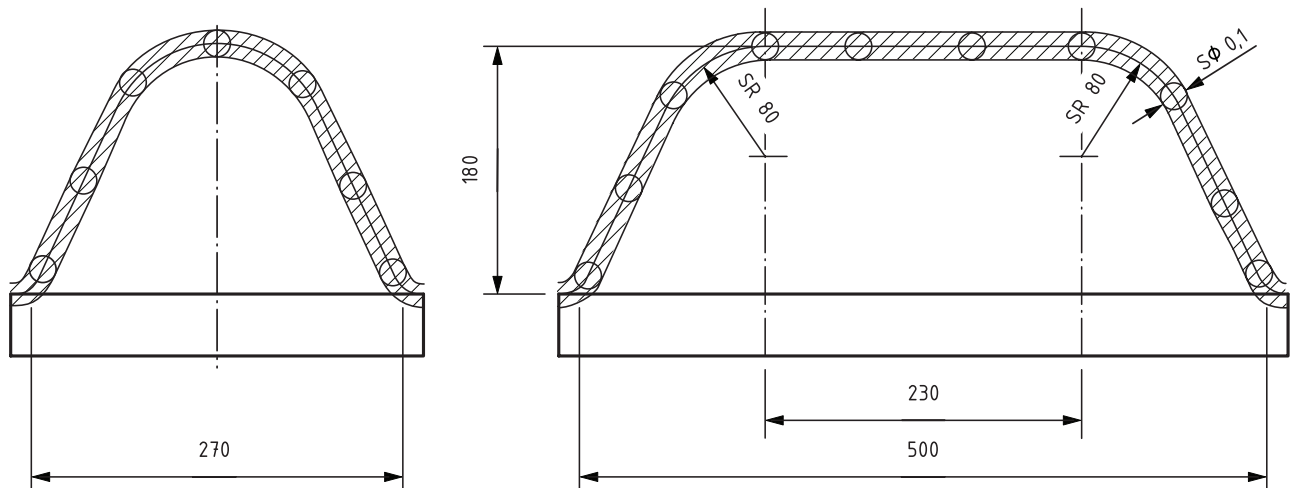

b) Interpretation (obsolete)

**Figure C.1 — Obsolete interpretation of the extent of the tolerated feature for a profile specification**

Using the tools and rules given in this document, a specification that is interpreted as given in [Figure C.1 b\)](#), can be indicated as shown in [Figure B.16 a\)](#).

**C.3** It was former practice to use the “all around” indication without any supplemental indication showing whether the indicated features should be considered individual features or one complex feature. This created an ambiguity, i.e. it was not clear whether the indication in [Figure C.2](#) should be interpreted as given in [Figure B.3 c\)](#), as given in [Figure B.4 c\)](#) or as given in [Figure B.7 c\)](#).

Instead, the indications shown in [Figure B.3 a\)](#) and b), [Figure B.4 a\)](#) and b) or [Figure B.7 a\)](#) and b) should be used, depending on which specification is desired (SZ, UF or CZ).

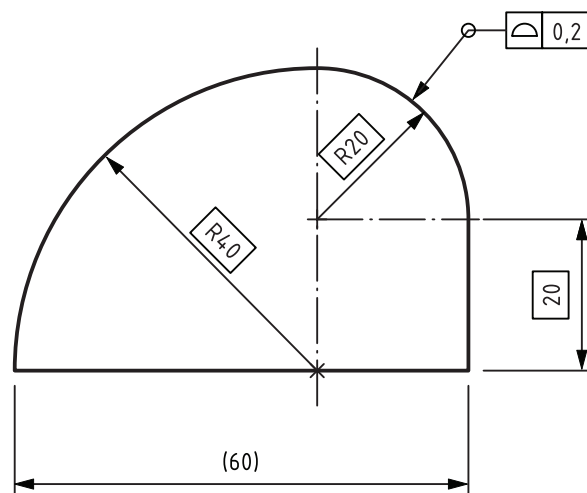

**Figure C.2 — Ambiguous “all around” indication without supplemental indications**

**C.4** The practice of relying on the drawing plane to function as collection plane in connection with the “all around” symbol in 2D has been deprecated to align the practices between 2D and 3D, see ISO 1101:2017, 9.1.2.

## Annex D (informative)

### Relation to the GPS matrix model

#### D.1 General

For full details about the GPS matrix model, see ISO 14638.

The ISO/GPS masterplan given in ISO 14638 gives an overview of the ISO/GPS system of which this document is a part. The fundamental rules of ISO/GPS given in ISO 8015 apply to this document and the default decision rules given in ISO 14253-1 apply to specifications made in accordance with this document, unless otherwise indicated.

#### D.2 Information about the document and its use

This document contains basic information for the geometrical tolerancing of profiles.

#### D.3 Position in the GPS matrix model

This document is a general GPS standard, which influences the chain links A, B and C of the chains of standards on form of lines and surfaces independent of datums and dependent on datums, as graphically illustrated in [Table D.1](#).

**Table D.1 — Fundamental and general ISO GPS standards matrix**

	Chain links						
	A	B	C	D	E	F	G
	Symbols and indications	Feature requirements	Feature properties	Conformance and non-conformance	Measurement	Measurement equipment	Calibrations
Size							
Distance							
Form	•	•	•				
Orientation	•	•	•				
Location	•	•	•				
Run-out							
Profile surface texture							
Areal surface texture							
Surface imperfections							

#### D.4 Related standards

The related standards are those of the chains of standards indicated in [Table D.1](#).

## Bibliography

- [1] ISO 2692, *Geometrical product specifications (GPS) — Geometrical tolerancing — Maximum material requirement (MMR), least material requirement (LMR) and reciprocity requirement (RPR)*
- [2] ISO 7083, *Technical drawings — Symbols for geometrical tolerancing — Proportions and dimensions*
- [3] ISO 5458:1998, *Geometrical Product Specifications (GPS) — Geometrical tolerancing — Positional tolerancing*
- [4] ISO 10579, *Geometrical product specifications (GPS) — Dimensioning and tolerancing — Non-rigid parts*
- [5] ISO 14253-1, *Geometrical product specifications (GPS) — Inspection by measurement of workpieces and measuring equipment — Part 1: Decision rules for proving conformity or nonconformity with specifications*
- [6] ISO 14638, *Geometrical product specifications (GPS) — Matrix model*







# British Standards Institution (BSI)

BSI is the national body responsible for preparing British Standards and other standards-related publications, information and services.

BSI is incorporated by Royal Charter. British Standards and other standardization products are published by BSI Standards Limited.

## About us

We bring together business, industry, government, consumers, innovators and others to shape their combined experience and expertise into standards-based solutions.

The knowledge embodied in our standards has been carefully assembled in a dependable format and refined through our open consultation process. Organizations of all sizes and across all sectors choose standards to help them achieve their goals.

## Information on standards

We can provide you with the knowledge that your organization needs to succeed. Find out more about British Standards by visiting our website at [bsigroup.com/standards](http://bsigroup.com/standards) or contacting our Customer Services team or Knowledge Centre.

## Buying standards

You can buy and download PDF versions of BSI publications, including British and adopted European and international standards, through our website at [bsigroup.com/shop](http://bsigroup.com/shop), where hard copies can also be purchased.

If you need international and foreign standards from other Standards Development Organizations, hard copies can be ordered from our Customer Services team.

## Copyright in BSI publications

All the content in BSI publications, including British Standards, is the property of and copyrighted by BSI or some person or entity that owns copyright in the information used (such as the international standardization bodies) and has formally licensed such information to BSI for commercial publication and use.

Save for the provisions below, you may not transfer, share or disseminate any portion of the standard to any other person. You may not adapt, distribute, commercially exploit, or publicly display the standard or any portion thereof in any manner whatsoever without BSI's prior written consent.

## Storing and using standards

Standards purchased in soft copy format:

- A British Standard purchased in soft copy format is licensed to a sole named user for personal or internal company use only.
- The standard may be stored on more than 1 device provided that it is accessible by the sole named user only and that only 1 copy is accessed at any one time.
- A single paper copy may be printed for personal or internal company use only.

Standards purchased in hard copy format:

- A British Standard purchased in hard copy format is for personal or internal company use only.
- It may not be further reproduced – in any format – to create an additional copy. This includes scanning of the document.

If you need more than 1 copy of the document, or if you wish to share the document on an internal network, you can save money by choosing a subscription product (see 'Subscriptions').

## Reproducing extracts

For permission to reproduce content from BSI publications contact the BSI Copyright & Licensing team.

## Subscriptions

Our range of subscription services are designed to make using standards easier for you. For further information on our subscription products go to [bsigroup.com/subscriptions](http://bsigroup.com/subscriptions).

With **British Standards Online (BSOL)** you'll have instant access to over 55,000 British and adopted European and international standards from your desktop. It's available 24/7 and is refreshed daily so you'll always be up to date.

You can keep in touch with standards developments and receive substantial discounts on the purchase price of standards, both in single copy and subscription format, by becoming a **BSI Subscribing Member**.

**PLUS** is an updating service exclusive to BSI Subscribing Members. You will automatically receive the latest hard copy of your standards when they're revised or replaced.

To find out more about becoming a BSI Subscribing Member and the benefits of membership, please visit [bsigroup.com/shop](http://bsigroup.com/shop).

With a **Multi-User Network Licence (MUNL)** you are able to host standards publications on your intranet. Licences can cover as few or as many users as you wish. With updates supplied as soon as they're available, you can be sure your documentation is current. For further information, email [subscriptions@bsigroup.com](mailto:subscriptions@bsigroup.com).

## Revisions

Our British Standards and other publications are updated by amendment or revision.

We continually improve the quality of our products and services to benefit your business. If you find an inaccuracy or ambiguity within a British Standard or other BSI publication please inform the Knowledge Centre.

## Useful Contacts

### Customer Services

**Tel:** +44 345 086 9001

**Email (orders):** [orders@bsigroup.com](mailto:orders@bsigroup.com)

**Email (enquiries):** [cservices@bsigroup.com](mailto:cservices@bsigroup.com)

### Subscriptions

**Tel:** +44 345 086 9001

**Email:** [subscriptions@bsigroup.com](mailto:subscriptions@bsigroup.com)

### Knowledge Centre

**Tel:** +44 20 8996 7004

**Email:** [knowledgecentre@bsigroup.com](mailto:knowledgecentre@bsigroup.com)

### Copyright & Licensing

**Tel:** +44 20 8996 7070

**Email:** [copyright@bsigroup.com](mailto:copyright@bsigroup.com)

### BSI Group Headquarters

389 Chiswick High Road London W4 4AL UK