

Metallic and oxide coatings — Measurement of coating thickness — Microscopical method

The European Standard EN ISO 1463:2004 has the status of a
British Standard

ICS 17.040.20; 25.220.40

National foreword

This British Standard is the official English language version of EN ISO 1463:2004. It is identical with ISO 1463:2003. It supersedes BS EN ISO 1463:1995 which is withdrawn.

The UK participation in its preparation was entrusted to Technical Committee STI/33, Electrodeposited and related coatings, which has the responsibility to:

- aid enquirers to understand the text;
- present to the responsible international/European committee any enquiries on the interpretation, or proposals for change, and keep the UK interests informed;
- monitor related international and European developments and promulgate them in the UK.

A list of organizations represented on this committee can be obtained on request to its secretary.

Cross-references

The British Standards which implement international or European publications referred to in this document may be found in the *BSI Catalogue* under the section entitled “International Standards Correspondence Index”, or by using the “Search” facility of the *BSI Electronic Catalogue* or of British Standards Online.

This publication does not purport to include all the necessary provisions of a contract. Users are responsible for its correct application.

Compliance with a British Standard does not of itself confer immunity from legal obligations.

Summary of pages

This document comprises a front cover, an inside front cover, the EN ISO title page, the EN ISO foreword page, the ISO title page, pages ii to iv, pages 1 to 11, the Annex ZA page, an inside back cover and a back cover.

The BSI copyright notice displayed in this document indicates when the document was last issued.

Amendments issued since publication

Amd. No.	Date	Comments

This British Standard was published under the authority of the Standards Policy and Strategy Committee on 5 January 2005

© BSI 5 January 2005

ISBN 0 580 45166 6

English version

**Metallic and oxide coatings - Measurement of coating thickness
- Microscopical method (ISO 1463:2003)**

Revêtements métalliques et couches d'oxyde - Mesurage
de l'épaisseur de revêtement - Méthode par coupe
micrographique (ISO 1463:2003)

Metall- und Oxidschichten - Schichtdickenmessung -
Mikroskopische Verfahren (ISO 1463:2003)

This European Standard was approved by CEN on 1 April 2004.

CEN members are bound to comply with the CEN/CENELEC Internal Regulations which stipulate the conditions for giving this European Standard the status of a national standard without any alteration. Up-to-date lists and bibliographical references concerning such national standards may be obtained on application to the Central Secretariat or to any CEN member.

This European Standard exists in three official versions (English, French, German). A version in any other language made by translation under the responsibility of a CEN member into its own language and notified to the Central Secretariat has the same status as the official versions.

CEN members are the national standards bodies of Austria, Belgium, Cyprus, Czech Republic, Denmark, Estonia, Finland, France, Germany, Greece, Hungary, Iceland, Ireland, Italy, Latvia, Lithuania, Luxembourg, Malta, Netherlands, Norway, Poland, Portugal, Slovakia, Slovenia, Spain, Sweden, Switzerland and United Kingdom.



EUROPEAN COMMITTEE FOR STANDARDIZATION
COMITÉ EUROPÉEN DE NORMALISATION
EUROPÄISCHES KOMITEE FÜR NORMUNG

Management Centre: rue de Stassart, 36 B-1050 Brussels

Foreword

The text of ISO 1463:2003 has been prepared by Technical Committee ISO/TC 107 "Metallic and other inorganic coatings" of the International Organization for Standardization (ISO) and has been taken over as EN ISO 1463:2004 by Technical Committee CEN/TC 262 "Metallic and other inorganic coatings", the secretariat of which is held by BSI.

This European Standard shall be given the status of a national standard, either by publication of an identical text or by endorsement, at the latest by November 2004, and conflicting national standards shall be withdrawn at the latest by November 2004.

This document supersedes EN ISO 1463:1994.

According to the CEN/CENELEC Internal Regulations, the national standards organizations of the following countries are bound to implement this European Standard: Austria, Belgium, Cyprus, Czech Republic, Denmark, Estonia, Finland, France, Germany, Greece, Hungary, Iceland, Ireland, Italy, Latvia, Lithuania, Luxembourg, Malta, Netherlands, Norway, Poland, Portugal, Slovakia, Slovenia, Spain, Sweden, Switzerland and United Kingdom.

Endorsement notice

The text of ISO 1463:2003 has been approved by CEN as EN ISO 1463:2004 without any modifications.

NOTE Normative references to International Standards are listed in Annex ZA (normative).

INTERNATIONAL
STANDARD

ISO
1463

Third edition
2003-03-01

**Metallic and oxide coatings —
Measurement of coating thickness —
Microscopical method**

*Revêtements métalliques et couches d'oxyde — Mesurage de
l'épaisseur de revêtement — Méthode par coupe micrographique*



Reference number
ISO 1463:2003(E)

Contents

Page

Foreword.....	iv
1 Scope	1
2 Normative references	1
3 Term and definition	1
4 Principle	1
5 Factors relating to measurement uncertainty	2
5.1 Surface roughness	2
5.2 Taper of cross-section	2
5.3 Deformation of coating	2
5.4 Rounding of edge of coating	2
5.5 Overplating	2
5.6 Etching	2
5.7 Smearing	2
5.8 Magnification	2
5.9 Calibration of stage micrometer	3
5.10 Calibration of micrometer eyepiece	3
5.11 Alignment	3
5.12 Uniformity of magnification	3
5.13 Lens quality	3
5.14 Orientation of eyepiece	3
5.15 Tube length	3
6 Preparation of cross-sections	4
7 Measurement	4
8 Measurement uncertainty	4
9 Test report	4
Annex A (informative) Guidance on the preparation and measurement of cross-sections	5
Annex B (informative) Taper of cross-section and measurement of tooth-constructed coatings	7
Annex C (informative) Some typical etchants for use at room temperature	10
Bibliography	11

Foreword

ISO (the International Organization for Standardization) is a worldwide federation of national standards bodies (ISO member bodies). The work of preparing International Standards is normally carried out through ISO technical committees. Each member body interested in a subject for which a technical committee has been established has the right to be represented on that committee. International organizations, governmental and non-governmental, in liaison with ISO, also take part in the work. ISO collaborates closely with the International Electrotechnical Commission (IEC) on all matters of electrotechnical standardization.

International Standards are drafted in accordance with the rules given in the ISO/IEC Directives, Part 2.

The main task of technical committees is to prepare International Standards. Draft International Standards adopted by the technical committees are circulated to the member bodies for voting. Publication as an International Standard requires approval by at least 75 % of the member bodies casting a vote.

Attention is drawn to the possibility that some of the elements of this document may be the subject of patent rights. ISO shall not be held responsible for identifying any or all such patent rights.

ISO 1463 was prepared by Technical Committee ISO/TC 107, *Metallic and other inorganic coatings*, Subcommittee SC 2, *Test methods*.

This third edition cancels and replaces the second edition (ISO 1463:1982), which has been technically revised.

Metallic and oxide coatings — Measurement of coating thickness — Microscopical method

1 Scope

This International Standard describes a method for the measurement of the local thickness of metallic coatings, oxide layers, and porcelain or vitreous enamel coatings, by the microscopical examination of cross-sections using an optical microscope.

WARNING — The use of this document may involve the use of hazardous materials, operations and equipment. This document does not address any health hazard and safety issues associated with its use. It is the responsibility of the user to establish appropriate health and safety practices and to take suitable action to comply with any national and/or local regulations prior to its use.

2 Normative references

The following referenced documents are indispensable for the application of this document. For dated references, only the edition cited applies. For undated references, the latest edition of the referenced document (including any amendments) applies.

ISO 2064, *Metallic and other inorganic coatings — Definitions and conventions concerning the measurement of thickness*

3 Term and definition

For the purposes of this document the following term and definition apply.

3.1

local thickness

the mean of the thickness measurements, of which a specified number is made within a reference area

[3.4 of ISO 2064:1996]

4 Principle

A portion of the test specimen is cut out and mounted. The mounted cross-section is prepared by suitable techniques of grinding, polishing and etching. The thickness of the coating cross-section is measured by means of a calibrated scale.

NOTE These techniques will be familiar to experienced metallographers, but some guidance is given in Clause 5 and in Annex A for less experienced operators.

5 Factors relating to measurement uncertainty

5.1 Surface roughness

If the coating or its substrate has a rough surface, one or both of the interfaces bounding the coating cross-section may be too irregular to permit accurate measurement. (See A.5.)

5.2 Taper of cross-section

If the plane of the cross-section is not perpendicular to the plane of the coating, the measured thickness will be greater than the true thickness; e.g., an inclination of 10° to the perpendicular will contribute a 1,5 % error.

NOTE B.1 provides guidance on taper cross-section.

5.3 Deformation of coating

Detrimental deformation of the coating can be caused by excessive temperature or pressure during mounting and preparation of cross-sections of soft coatings or coatings that melt at a low temperature, and also by excessive abrasion of brittle materials during preparation of cross-sections.

5.4 Rounding of edge of coating

If the edge of the coating cross-section is rounded, i.e. if the coating cross-section is not completely flat up to its edges, the true thickness cannot be observed microscopically. Edge rounding can be caused by improper mounting, grinding, polishing or etching. It is usually minimized by overplating the test specimen before mounting. (See A.2.)

5.5 Overplating

Overplating of the test specimen protects the coating edges during preparation of cross-sections and thus prevents erroneous measurement. Removal of coating material during surface preparation for overplating can result in a low thickness measurement.

5.6 Etching

Optimum etching produces a clearly defined and narrow dark line at the interface of two metals. Excessive etching produces a poorly defined or wide line that can result in erroneous measurement.

5.7 Smearing

Improper polishing or overplating with a softer metal may cause smearing of one metal over the other metal, obscuring the boundary between the coating and the substrate. This problem may be alleviated by repeating the preparation of the cross section of the coated metal until repeatability of the thickness measurement (see A.3 and A.5) is obtained and also by over-plating with a harder metal.

5.8 Magnification

For any given coating thickness, measurement uncertainty generally increase with decreasing magnification. The magnification should be chosen so that the field of view is between $1,5 \times$ and $3 \times$ the coating thickness.

5.9 Calibration of stage micrometer

Any error in calibration of the stage micrometer will be reflected in the measurement of the specimen. Errors of several percent are not unrealistic unless the scale has been calibrated or has been certified by a responsible supplier. A generally satisfactory means of calibration is to assume that the stated length of the full scale is correct, to measure each subdivision with a filar micrometer, and to calculate the length of each sub-division by simple proportion.

5.10 Calibration of micrometer eyepiece

A filar micrometer eyepiece generally provides the most satisfactory means of making the measurement of the specimen. The measurement will be no more accurate than the calibration of the eyepiece. As calibration is operator dependent, the eyepiece shall be calibrated by the person making the measurement.

Repeated calibrations of the micrometer eyepiece can be reasonably expected to have a spread of less than 1 %. The distance between the two lines of a stage micrometer used for the calibration shall be known to within 0,2 μm or 0,1 %, whichever is the greater. If a stage micrometer is not certified for accuracy, it shall be calibrated.

NOTE The measurement uncertainty of some stage micrometers is certified by the manufacturer. Other stage micrometers have been found to have a measurement uncertainty of 1 μm or 2 μm for a measurement distance of 2 mm and by 0,4 μm and more for measurement distances of 0,1 mm and 0,01 mm.

Some image splitting micrometer eyepieces have a non-linearity that introduces an error of up to 1 % for short measurement distances.

5.11 Alignment

Errors can be introduced by backlash in the movement of the micrometer eyepiece. To eliminate this error, ensure that the final motion during alignment of the hairline is always made in the same direction.

5.12 Uniformity of magnification

Because errors can occur if the magnification is not uniform over the entire field, ensure that both the calibration and the measurement are made over the same portion of the field with the measured boundaries centred about the optical axis.

5.13 Lens quality

As lack of sharpness of the image contributes to the uncertainty of the measurement, ensure that good quality lenses are used.

NOTE Sometimes, image sharpness can be improved by using monochromatic light.

5.14 Orientation of eyepiece

Ensure that the movement of the hairline of the eyepiece for alignment is perpendicular to the boundaries of the coating cross-section; e.g., 10° misalignment will contribute a 1,5 % error.

5.15 Tube length

A change in tube length causes a change in magnification and, if this change occurs between the time of calibration and the time of measurement, the measurement will be in error. Take care to avoid a change in tube length, which can occur when the eyepiece is repositioned within the tube, when the focus of the eyepiece tube is changed and, for some microscopes, when the fine focus is adjusted.

6 Preparation of cross-sections

Prepare, mount, grind, polish, and etch the specimen so that:

- a) the cross-section is perpendicular to the coating;
- b) the surface is flat and the entire width of the coating image is simultaneously in focus at the magnification to be used for the measurement;
- c) all material deformed by cutting or cross-sectioning is removed;
- d) the boundaries of the coating cross-section are sharply defined by no more than contrasting appearance, or by a narrow, well defined, line.

NOTE Further guidance is given in Clause 5 and in Annex A. Some typical etchants are described in Annex C.

7 Measurement

7.1 Give appropriate attention to the factors listed in Clause 5 and Annex A.

7.2 Calibrate the microscope and its measuring device with a certified or calibrated stage micrometer.

7.3 Measure the width of the image of the coating cross-section on at least five points distributed along a length of the microsection.

NOTE Guidance on the measurement of taper of cross-section and of tooth-constructed coatings is given in Annex B.

8 Measurement uncertainty

The microscope and associated equipment, its use, its calibration and the method of preparation of the cross-section shall be chosen so as to allow the coating thickness to be determined to within 1 μm or 10 %, whichever is the greater, of the actual coating thickness. The method is capable of giving an absolute measurement uncertainty of 0,8 μm , and for thicknesses greater than 25 μm a reasonable measurement uncertainty is of the order of 5 % or better (see also B.3.). However, with careful preparation of the specimen and the application of suitable instruments this method is capable of providing a measurement uncertainty of 0,4 μm under reproducible conditions.

9 Test report

The test report shall include the following information:

- a) reference of this document, i.e. ISO 1463;
- b) identity of the test specimen;
- c) results of the test, indicating
 - 1) location on the coated item at which the cross-section was made;
 - 2) measured thickness, in micrometres (millimetres if greater than 1 mm) at each point (see 7.3);
 - 3) local thickness, i.e., the arithmetic mean of the measured thicknesses;
- d) any deviations from the procedure specified;
- e) any unusual features (anomalies) observed during the test;
- f) date of test.

Annex A (informative)

Guidance on the preparation and measurement of cross-sections

A.1 Introduction

The preparation of test specimens and measurement of coating thickness are greatly dependent on individual techniques and there is a variety of suitable techniques available. It is not reasonable to specify only one set of techniques, and it is impractical to include all suitable techniques. The techniques described in this annex are intended as guidance for metallographers not experienced in measurements of coating thickness.

A.2 Mounting

To prevent rounding of the edge of the coating cross-section, the free surface of the coating should be supported so that there is no space between the coating and its support. This is usually achieved by overplating the specimen with a coating of a metal of similar hardness, at least 10 µm thick. For hard, brittle coatings (e.g. oxide or chromium coatings), tightly wrapping the specimen in soft aluminium foil before mounting has proved successful.

If the coating is soft, overplating with a metal that is softer will make polishing more difficult, because the softer metal tends to be polished away more rapidly.

Overplating of zinc or cadmium coatings with copper can cause difficulty because of the tendency of dissolved copper to deposit on the coatings during subsequent etching. It is better to overplate zinc with cadmium and vice versa.

A.3 Grinding and polishing

It is essential to keep the cross-section surface of the mount perpendicular to the coating. This is facilitated by incorporating additional pieces of a similar metal near the outer edges of the plastic mounting, by periodically changing the direction of grinding (rotating through 90°) and by keeping the grinding time and pressure to a minimum. If, before grinding, reference marks are inscribed on the sides of the mount, any inclination from horizontal is easily measurable

Grind the mounted test specimens on suitable abrasive paper, using an acceptable lubricant, such as water or white spirit, and apply minimum pressure to avoid bevelling of the surface. Initial grinding should employ 100 grade or 180 grade abrasive to reveal the true test specimen profile and to remove any deformed metal. Subsequently, use grades 240, 320, 500 and 600 without exceeding grinding times of 30 s to 40 s on each paper; alter the direction of scratches by 90° for each change of paper. A final polish for 2 min to 3 min on a rotating wheel charged with 4 µm to 8 µm diamond paste particles and lubrication with white spirit should suffice to remove scratches for final examination. If an especially high degree of surface finish is required, a further treatment, using diamond paste of approximately 1 µm particles, may be used.

If very soft materials are being prepared, abrasive particles can become embedded during grinding. This may be minimized by totally immersing abrasive papers in a lubricant during grinding or by using a copious flow of lubricant. If abrasive particles do become embedded, they may be removed by applying a short, light hand polish with metal polish after grinding and before diamond finishing or by one or more cycles of alternate etching and polishing.

A.4 Etching

Etching is usually advisable in order to promote contrast between the metal layers to remove traces of smeared metal and to develop a fine line at the boundary of the coating. Some typical etchants are given in Annex C.

A.5 Measurement

The measuring device may be a filar micrometer or a micrometer eyepiece. The latter has lower precision. An image splitting eyepiece is advantageous for thin coatings on rough substrate surfaces. Measurement of the image projected on a ground glass plate is usually less satisfactory because of the lack of sharpness of the image and poor legibility of the rule when the projected image is visible.

The measuring device should be calibrated at least once before and once after a measurement, unless repeated experience indicates otherwise.

When making calibration and coating measurements both should be made by the same operator, the stage micrometer and the coating should be centred in the field and each measurement at a point should be made at least twice and averaged.

For critical and referee measurements, all steps for preparation of cross-sections and measurement of coating thickness, from grinding with 600 grade or coarser abrasive, up to and including the determination of coating thickness, should be performed at least twice. With good techniques and equipment, and smooth coating and substrate surfaces, repeatability within 2 % or 0,5 μm , whichever is the greater, is reasonable.

Some microscopes are subject to a spontaneous movement of the stage relative to the objective, possibly due to non-uniform thermal effects from the light source. Such a movement during the measurement can cause an erroneous measurement at moderate and high magnifications. This can be minimized by completing the measurement quickly and by measuring each interval twice, once from left to right and once from right to left.

Annex B (informative)

Taper of cross-section and measurement of tooth-constructed coatings

B.1 Taper of cross-section

If the sample position deviates from the perpendicular (see Figure B.1), higher measuring values will be obtained (see 5.2).

The coating thickness d can be calculated using the following equation:

$$d = d' \cos \alpha$$

where

d is the coating thickness when $\alpha = 0$;

α is the deviation of the cross-section from the perpendicular of the coating surface, in degrees;

d' is the measured coating thickness when $\alpha \neq 0$.

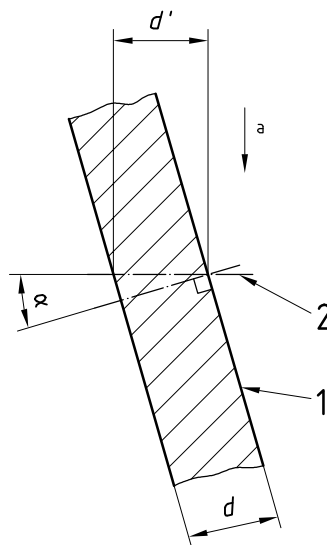

Key

- 1 coating surface
- 2 section
- a Direction of observation

Figure B.1 — Deviation of the cross-section by the angle α

B.2 Measurement of tooth-constructed coatings

B.2.1 Principle

This method can be used for determining the coating thickness for coatings bounded by a tooth construction, e.g. thermochemically produced boride-nitride coatings.

The coating thickness is magnified $200\times$ and measured by a screen line distance of 2 mm between the boundary line of the coating over a suitable total length of, e.g. 100 mm (see Figure B.2).

B.2.2 Evaluation

The arithmetical average value for coatings with tooth-construction is calculated from single values. The standard deviation provides an indication of the irregularities of the boundary surface (i.e. the degree of tooth construction).

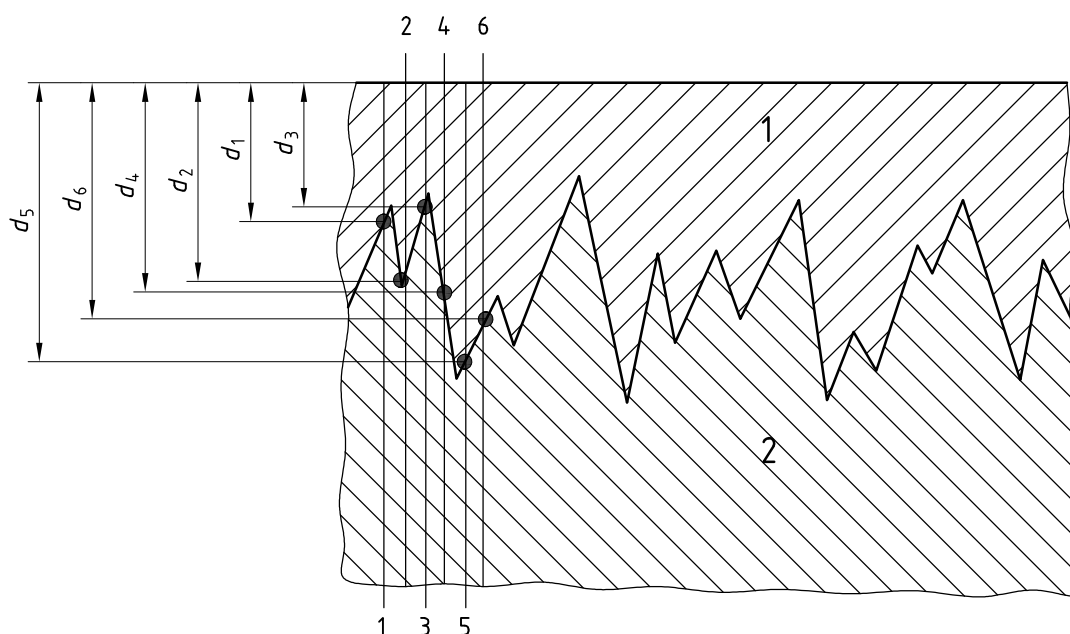

Key

- 1 coating
- 2 substrate

Figure B.2 — Diagrammatic representation of the thickness determination of coatings with tooth construction

B.3 Empirical values for the standard deviation of measurements obtained by light microscopy

Under reproducible conditions, the standard deviation, σ , is $0,3\ \mu\text{m}$. Under comparable conditions, the standard deviation is $0,8\ \mu\text{m}$.

Based on the stated standard deviations, Table B.1 indicates the confidence interval of q , the local coating thickness. The values in the table apply to a statistical certainty of 95 % calculated with the formula (simplified notation):

$$q = \pm \frac{1,96}{\sqrt{n}} \times \sigma$$

where

n is the number of measurement values from which the local coating thickness has been calculated;

σ is the standard deviation.

Therefore 95 % of all measurement results are within the range of the local coating thickness $\pm q$ (see [1]).

Table B.1 — Relative error in % of the local coating thickness with a statistical certainty of 95 %

Local coating thickness q (μm)	Reproducible conditions		Statement of reproducibility requiring definition of reproducibility	
	$\sigma = 0,3 \mu\text{m}$		$\sigma = 0,8 \mu\text{m}$	
	$n = 3$	$n = 10$	$n = 3$	$n = 10$
1	34	20	90	50
5	7	4	18	10
10	4	2	9	5
50	0,7	0,4	1,8	1
100	0,4	0,2	0,9	0,5

Annex C (informative)

Some typical etchants for use at room temperature

WARNING: Precautions should be taken in the preparation, use, handling and disposal of these etchants.

Etchant	Application
<p>1</p> <p>Nitric acid solution ($\rho = 1,42$ g/ml): 5 ml Ethanol solution, volume fraction 95 %: 95 ml</p> <p>WARNING This mixture can be explosively unstable, particularly if heated.</p>	<p>For nickel or chromium coatings on steel. Etches steel. This etchant should be freshly prepared.</p>
<p>2</p> <p>Iron(III) chloride hexahydrate ($\text{FeCl}_3 \cdot 6\text{H}_2\text{O}$): 10 g Hydrochloric acid solution ($\rho = 1,16$ g/ml): 2 ml Ethanol solution, volume fraction 95 %: 98 ml</p>	<p>For gold, lead, silver, nickel and copper coatings on steel, copper and copper alloys. Etches steel, copper and copper alloys.</p>
<p>3</p> <p>Nitric acid solution ($\rho = 1,42$ g/ml): 50 ml Glacial acetic acid: ($\rho = 1,16$ g/ml): 50 ml</p>	<p>For determination of thickness of individual layers of multi-layer coatings of nickel on steel and copper alloys; distinguishes each layer of nickel by identifying structures. Etches nickel; excessive attack on steel and copper alloys.</p>
<p>4</p> <p>Ammonium persulfate: 10 g Ammonium hydroxide solution ($\rho = 0,88$ g/ml): 2 ml Distilled water: 93 ml</p>	<p>For tin and tin alloy coatings on copper and copper alloys. Etches copper and copper alloys. This etchant should be freshly prepared.</p>
<p>5</p> <p>Nitric acid solution ($\rho = 1,42$ g/ml): 5 ml Hydrofluoric acid solution ($\rho = 1,14$ g/ml): 2 ml Distilled water: 93 ml</p>	<p>For nickel and copper coatings on aluminium and its alloys. Etches aluminium and its alloys.</p>
<p>6</p> <p>Chromium (IV) oxide (CrO_3): 20 g Sodium sulfate: 1,5 g Distilled water: 100 ml</p>	<p>For nickel and copper on zinc-based alloys. Also suitable for zinc and cadmium coatings on steel. Etches zinc, zinc-based alloys and cadmium.</p>
<p>7</p> <p>Hydrofluoric acid solution ($\rho = 1,14$ g/ml): 2 ml Distilled water: 98 ml</p>	<p>For anodized aluminium alloys. Etches aluminium and its alloys.</p>

Bibliography

- [1] BARGHOORN, H., *Vergleichende Untersuchungen von Schichtdicke-Messverfahren*, Metalloberfläche, 1955, 7, pp. 8-11
- [2] RAY, G.P., *Thickness testing of electroplated and related coatings*, Electrochemical Publications Ltd., Asahi House, 10 Church Road, Port Erin, Isle of Man, U.K., 1993, ISBN 0 901150 27 4¹⁾

1) Available from the Institute of Metal Finishing, Exeter House, 48 Holloway Head, Birmingham B1 1NQ, U.K.

Annex ZA
(normative)**Normative references to international publications
with their relevant European publications**

This European Standard incorporates by dated or undated reference, provisions from other publications. These normative references are cited at the appropriate places in the text and the publications are listed hereafter. For dated references, subsequent amendments to or revisions of any of these publications apply to this European Standard only when incorporated in it by amendment or revision. For undated references the latest edition of the publication referred to applies (including amendments).

NOTE Where an International Publication has been modified by common modifications, indicated by (mod.), the relevant EN/HD applies.

<u>Publication</u>	<u>Year</u>	<u>Title</u>	<u>EN</u>	<u>Year</u>
ISO 2064	1996	Metallic and other inorganic coatings - Definitions and conventions concerning the measurement of thickness	EN ISO 2064	2000

BSI — British Standards Institution

BSI is the independent national body responsible for preparing British Standards. It presents the UK view on standards in Europe and at the international level. It is incorporated by Royal Charter.

Revisions

British Standards are updated by amendment or revision. Users of British Standards should make sure that they possess the latest amendments or editions.

It is the constant aim of BSI to improve the quality of our products and services. We would be grateful if anyone finding an inaccuracy or ambiguity while using this British Standard would inform the Secretary of the technical committee responsible, the identity of which can be found on the inside front cover. Tel: +44 (0)20 8996 9000. Fax: +44 (0)20 8996 7400.

BSI offers members an individual updating service called PLUS which ensures that subscribers automatically receive the latest editions of standards.

Buying standards

Orders for all BSI, international and foreign standards publications should be addressed to Customer Services. Tel: +44 (0)20 8996 9001. Fax: +44 (0)20 8996 7001. Email: orders@bsi-global.com. Standards are also available from the BSI website at <http://www.bsi-global.com>.

In response to orders for international standards, it is BSI policy to supply the BSI implementation of those that have been published as British Standards, unless otherwise requested.

Information on standards

BSI provides a wide range of information on national, European and international standards through its Library and its Technical Help to Exporters Service. Various BSI electronic information services are also available which give details on all its products and services. Contact the Information Centre. Tel: +44 (0)20 8996 7111. Fax: +44 (0)20 8996 7048. Email: info@bsi-global.com.

Subscribing members of BSI are kept up to date with standards developments and receive substantial discounts on the purchase price of standards. For details of these and other benefits contact Membership Administration. Tel: +44 (0)20 8996 7002. Fax: +44 (0)20 8996 7001. Email: membership@bsi-global.com.

Information regarding online access to British Standards via British Standards Online can be found at <http://www.bsi-global.com/bsonline>.

Further information about BSI is available on the BSI website at <http://www.bsi-global.com>.

Copyright

Copyright subsists in all BSI publications. BSI also holds the copyright, in the UK, of the publications of the international standardization bodies. Except as permitted under the Copyright, Designs and Patents Act 1988 no extract may be reproduced, stored in a retrieval system or transmitted in any form or by any means – electronic, photocopying, recording or otherwise – without prior written permission from BSI.

This does not preclude the free use, in the course of implementing the standard, of necessary details such as symbols, and size, type or grade designations. If these details are to be used for any other purpose than implementation then the prior written permission of BSI must be obtained.

Details and advice can be obtained from the Copyright & Licensing Manager. Tel: +44 (0)20 8996 7070. Fax: +44 (0)20 8996 7553. Email: copyright@bsi-global.com.