

BRITISH STANDARD

**BS EN ISO
1402 : 1997**

Rubber and plastics hoses and hoses assemblies — Hydrostatic testing

The European Standard EN ISO 1402 : 1996 has the status of a
British Standard

ICS 23.040.70

NO COPYING WITHOUT BSI PERMISSION EXCEPT AS PERMITTED BY COPYRIGHT LAW



S

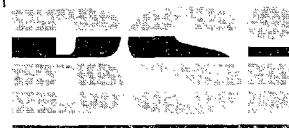

BS EN ISO 1402 : 1997

Committees responsible for this British Standard

The preparation of this British Standard was entrusted by Technical Committee PRI/66, Rubber and plastics tubing, hoses and hose assemblies, to Subcommittee PRI/66/4, Methods of test, upon which the following bodies were represented:

- British Fluid Power Association
- British Rubber Manufacturers Association Ltd.
- Energy Industries Council
- Ministry of Defence
- Society of Motor Manufacturers and Traders Limited

This British Standard, having been prepared under the direction of the Sector Board for Materials and Chemicals, was published under the authority of the Standards Board and comes into effect on 15 January 1997

© BSI 1997

Amendments issued since publication

Amd. No.	Date	Text affected

The following BSI references relate to the work on this standard:
 Committee reference PRI/66/4
 Draft for comment 91/48181 DC

ISBN 0 580 26910 8

Contents

	Page
Committees responsible	Inside front cover
National foreword	ii
Foreword	2
Method	
1 Scope	3
2 Normative references	3
3 General	3
4 Apparatus	3
5 Test pieces	3
6 Application of hydrostatic pressure	4
7 Hydrostatic pressure tests	4
8 Test report	6
Annex	
ZA (normative) Normative references to international publications with their relevant European publications	8
Figures	
1 Measurements of dimensional stability	7
2 Measurements of amount of twisting	7



S

National foreword

This British Standard has been prepared by Subcommittee PRI/66/4 and is the English language version of EN ISO 1402 : 1996 *Rubber and plastics hoses and hose assemblies — Hydrostatic testing* published by the European Committee for Standardization (CEN). It is identical with ISO 1402 : 1994 published by the International Organization for Standardization (ISO). ISO 1402 was produced as a result of international discussions in which the United Kingdom took an active part. It supersedes BS 5173 : Part 102 : Section 102.1 : 1991 which is withdrawn.

EN ISO 1402 : 1996 has been approved by CEN member bodies under the weighted voting procedures introduced in 1988 to coincide with the introduction of 'New Approach' Directives from the Commission of the European Community.

Cross-references

Publication referred to	Corresponding British Standard
ISO 471 : 1984 ¹⁾	BS 903 <i>Physical testing of rubber</i> Part A35 : 1995 <i>Temperatures, humidities and times for conditioning and testing of test pieces</i>
EN 24671 : 1993 (ISO 4671 : 1984)	BS EN 24671 : 1993 <i>Rubber and plastics hose and hose assemblies. Methods of measurement of dimensions</i>
ISO 7751 : 1991	BS 6596 : 1992 <i>Specification for ratios of proof and burst pressure to design working pressure for rubber and plastics hoses and hose assemblies</i>

Compliance with a British Standard does not of itself confer immunity from legal obligations.

¹⁾ This standard has been superseded by ISO 471 : 1995 with which the British Standard cited is identical.

EUROPEAN STANDARD
NORME EUROPÉENNE
EUROPÄISCHE NORM

EN ISO 1402

August 1996

ICS 23.040.70

Descriptors: Rubber products, plastics products, rubber hoses, plastics hoses, tests, hydrostatic tests, determination, dimensional stability

English version

Rubber and plastics hoses and hose assemblies — Hydrostatic testing

(ISO 1402 : 1994)

Tuyaux et flexibles en caoutchouc et en
plastique — Essais hydrostatiques
(ISO 1402 : 1994)

Gummi- und Kunststoffschläuche und
-Schlauchleitungen — Hydrostatische Prüfung
(ISO 1402 : 1994)

This European Standard was approved by CEN on 1996-02-26. CEN members are bound to comply with the CEN/CENELEC Internal Regulations which stipulate the conditions for giving this European Standard the status of a national standard without any alteration.

Up-to-date lists and bibliographical references concerning such national standards may be obtained on application to the Central Secretariat or to any CEN member.

This European Standard exists in three official versions (English, French, German). A version in any other language made by translation under the responsibility of a CEN member into its own language and notified to the Central Secretariat has the same status as the official versions.

CEN members are the national standards bodies of Austria, Belgium, Denmark, Finland, France, Germany, Greece, Iceland, Ireland, Italy, Luxembourg, Netherlands, Norway, Portugal, Spain, Sweden, Switzerland and United Kingdom.

CEN

European Committee for Standardization
Comité Européen de Normalisation
Europäisches Komitee für Normung

Central Secretariat: rue de Stassart 36, B-1050 Brussels

© 1996 Copyright reserved to CEN members

Ref. No. EN ISO 1402 : 1996 E



* S *

Foreword

The text of the International Standard from Technical Committee ISO/TC 45, Rubber and rubber products, of the International Organization for Standardization (ISO) has been taken over as an European Standard by Technical Committee CEN/TC 218, Rubber and plastics hoses and hose assemblies, the secretariat of which is held by BSI.

This European Standard shall be given the status of a national standard, either by publication of an identical text or by endorsement, at the latest by February 1997, and conflicting national standards shall be withdrawn at the latest by February 1997.

According to the CEN/CENELEC Internal Regulations, the National standards organizations of the following countries are bound to implement this European Standard: Austria, Belgium, Denmark, Finland, France, Germany, Greece, Iceland, Ireland, Italy, Luxembourg, Netherlands, Norway, Portugal, Spain, Sweden, Switzerland and the United Kingdom.

NOTE. Normative references to International Standards are listed in annex ZA (normative)

Rubber and plastics hoses and hose assemblies — Hydrostatic testing

1 Scope

This International Standard specified methods for the hydrostatic testing of rubber and plastics hoses and hose assemblies, including methods for the determination of dimensional stability.

2 Normative references

The following standards contain provisions which, through reference in this text, constitute provisions of this International Standard. At the time of publication, the editions indicated were valid. All standards are subject to revision, and parties to agreements based on this International Standard are encouraged to investigate the possibility of applying the most recent editions of the standards indicated below. Members of IEC and ISO maintain registers of currently valid International Standards.

ISO 471:—¹⁾ *Rubber — Times, temperatures and humidities for conditioning and testing.*

ISO 4671:1984, *Rubber and plastics hose and hose assemblies — Methods of measurement of dimensions.*

ISO 7751:1991, *Rubber and plastics hoses and hose assemblies — Ratios of proof and burst pressure to design working pressure.*

3 General

Unless otherwise specified, all tests shall be carried out at standard temperature (see ISO 471).

4 Apparatus

4.1 Pressure source, capable of applying pressure at the rate specified in 6.2.2, up to the required test pressure.

4.2 Calibrated pressure gauge or pressure transducers with digital readouts, chosen for each test so that the test pressure is between 15 % and 85 % of the full-scale reading.

In the interest of accuracy, calibrated pressure gauges or pressure transducers with digital readouts shall be checked at frequent intervals and the fitting of restrictors is recommended to minimize shock damage.

4.3 Sliding vernier callipers or micrometer, and measuring tape.

5 Test pieces

5.1 Hose assemblies

When hose assemblies are to be tested, the manufactured assembly length shall be used for the test.

5.2 Hoses

The hydrostatic pressure and burst tests shall be carried out on a hose test piece with a minimum free length, excluding end fittings and end reinforcements, of 600 mm when deformation is to be measured and 300 mm when it is not.

1) To be published. (Combination and revision of ISO 471:1983 and ISO 1826:1981)



S

5.3 Number of test pieces

At least two test pieces shall be tested.

6 Application of hydrostatic pressure

6.1 General

Water or another liquid suitable for the hose under test shall be used as the test medium.

WARNING — Hoses and hose assemblies pressurized by liquids can fail in a potentially dangerous manner. For this reason, the test shall be performed in a suitable enclosure. Also the use of air and other gases as test media shall be avoided because of the risk to operators. In special cases, where such media are required for the tests, strict safety measures are imperative. Furthermore, it is stressed that, even when a liquid is used as the test medium, it is essential that all air is expelled from the test piece because of the risk of injury to the operator due to the sudden expansion of trapped air released when the hose bursts.

6.2 Procedure

6.2.1 Fill the test piece with test liquid, expelling all air, and connect to the test equipment. Close the valve and apply the hydrostatic pressure at a uniform rate of increase. Measure the pressure using a calibrated pressure gauge or pressure transducer with digital readout (4.2).

NOTE 1 It is important to allow unrestricted movement of the free or plugged end of the test piece during the test.

6.2.2 The rate of pressure increase shall be constant and chosen to reach the final pressure after between 30 s and 60 s for hoses with nominal inside diameters up to 50 mm. For hoses with nominal inside diameters greater than 50 mm and less than or equal to 250 mm, the time needed to reach the final pressure shall be between 60 s and 240 s. For hoses with nominal inside diameters larger than 250 mm, the time needed to reach the final pressure shall be decided between the manufacturer and user.

7 Hydrostatic pressure tests

7.1 Proof pressure hold test

When proof pressure tests are used to determine leakage of hoses or hose assemblies, apply the specified proof pressure in accordance with 6.2.2 and hold it for not less than 30 s or more than 60 s, unless

otherwise specified in the product standard, examining the test pieces during this period for evidence of leakage, cracking, abrupt distortions indicating irregularity in material or manufacture, or other signs of failure.

Unless otherwise specified for the hose, the proof pressure shall be related to the design working pressure by the ratio given in ISO 7751.

NOTE 2 The test is not applicable to curved hose.

7.2 Measurement of deformation under pressure

7.2.1 General procedure

When tests for determining change in length, change in internal diameter and twisting are required, straighten the hose, lay it out horizontally for inspection and apply a hydrostatic pressure of 0,07 MPa when this is necessary to stabilize the hose. Make three reference marks (A, B and C) on the outer surface of the hose, the middle mark (B) being made approximately midway along the length of the hose, and the two outer marks (A and C) being 250 mm from B. Each mark shall consist of an arc on the circumference of the hose through which is drawn a straight line perpendicular to the arc, the three straight lines being colinear (see figure 1).

Maintain the initial pressure of 0,07 MPa (if applied) and make the appropriate measurements (see 7.2.2, 7.2.3 and 7.2.4) at the reference marks.

Apply the specified test pressure at the rate specified in 6.2.2 and maintain it for 1 min before making the test measurements, which shall then be made as quickly as possible to avoid prolonging the test period.

NOTE 3 The test pressure will be specified in the appropriate hose product specification and could be the design working pressure, the proof pressure or any other pressure below the proof pressure at which the hose deformation characteristics are to be measured.

7.2.2 Change in length

Measure the length between the two outermost reference marks (A and C) with an accuracy of ± 1 mm, using the measuring tape (4.3), at the initial pressure (0 or 0,07 MPa) and at the specified test pressure.

Calculate the change in length, Δl , expressed as a percentage of the original length, from the equation

$$\Delta l = \frac{l_1 - l_0}{l_0} \times 100$$

where

- l_0 is the distance between the two outermost reference marks (A and C) measured at the initial pressure;
- l_1 is the distance between the same two reference marks measured at the specified test pressure.

7.2.3 Change in external diameter

7.2.3.1 General

The external diameter should preferably be determined from measurements of circumference made with an accuracy of 1 mm using the measuring tape (see ISO 4671). The measurements may, however, be made directly, using sliding vernier callipers having a minimum useful tip width of 5 mm.

7.2.3.2 Determination by measuring the change in external circumference

Using the measuring tape (4.3), measure the circumference at each of the three reference marks (A, B and C) at the initial pressure (0 or 0,07 MPa) and at the specified test pressure.

Calculate the change in diameter ΔD , expressed as a percentage of the original diameter, from the equation

$$\Delta D = \frac{\Sigma C_1 - \Sigma C_0}{\Sigma C_0} \times 100$$

where

- ΣC_0 is the sum of the circumferences at the three reference marks measured at the initial pressure;
- ΣC_1 is the sum of the circumferences at the three reference marks measured at the specified test pressure.

7.2.3.3 Direct measurement of change in external diameter

Using the sliding vernier callipers (4.3), measure two perpendicular diameters at each of the three reference marks at the initial pressure (0 or 0,07 MPa) and at the specified test pressure.

Calculate the change in diameter ΔD , expressed as a percentage of the original diameter, from the equation

$$\Delta D = \frac{\Sigma D_1 - \Sigma D_0}{\Sigma D_0} \times 100$$

where

- ΣD_0 is the sum of the six diameters measured at the reference marks at the initial pressure;
- ΣD_1 is the sum of the six diameters measured at the reference marks at the specified test pressure.

7.2.4 Twisting

If twisting of the hose develops under pressure, the original lines forming the reference marks will take up a helical pattern (see figure 2).

With the hose at the specified test pressure, project a straight line along the length of the hose from reference mark A until it intersects, at C', the circular arc at reference point C.

Then measure the length s of the circular arc CC' to the nearest millimetre, using the measuring tape (4.3).

Calculate the amount of twisting per metre, T , expressed in degrees, from the equation

$$T = \frac{s \times 360}{C_c \times l_0}$$

where

- C_c is the circumference at reference mark C, measured as described in 7.2.3.1;
- l_0 is the distance between A and C as measured in 7.2.2.

7.2.5 Warping

Warping in hose tests is the deviation from a straight line drawn from fitting to fitting in a plane parallel to the surface on which the hose rests at the initial pressure (0 or 0,07 MPa). A tightly stretched cord may be used to establish the straight line from centre to centre of the fittings. The amount of warping at the specified test pressure is the maximum deviation of any portion of the hose from the straight line drawn from centre to centre of the fittings at the initial pressure. Express warping as the distance from this line to the centreline of the hose at the point of maximum deviation. Report the result to the nearest 5 mm.

7.3 Burst pressure test

Increase the pressure at a rate in accordance with 6.2.2 until the hose or hose assembly fails. The pos-



S

ition and mode of failure shall be recorded in the test report.

Any failure caused by blowing off of fittings, leakage or bursts within 25 mm of a fitting or within a distance equal to the external diameter of the hose, whichever is greater, shall not be interpreted as a true hose burst.

7.4 Leakage test

7.4.1 Test pieces

The test pieces for the leakage test shall comprise unaged hose assemblies on which the end fittings have been attached for not more than 30 days and not less than 1 day.

7.4.2 Procedure

Subject the test assemblies to a specified hydrostatic pressure equal to 70 % of the specified minimum burst pressure. Maintain this specified test pressure for 5 min \pm 0,5 min and then reduce it to zero. Re-apply the specified test pressure and maintain it for a further period of 5 min \pm 0,5 min. This is considered to be a destructive test and the test assemblies shall be destroyed after test.

7.4.3 Criteria for failure

There shall be no leakage or evidence of failure.

Leakage at the end fitting, fitting blow-off or rupture of the hose adjacent to the fitting shall be considered as failures in the performance of the assembly.

NOTE 4 Such failures do not necessarily demonstrate an inability of the hose to meet the specified requirements with an alternative fitting.

8 Test report

The test report shall include the following particulars for each test undertaken:

- a) a full description of the hose and, where applicable, hose assembly tested;
- b) a reference to this International Standard, i.e. ISO 1402;
- c) the method used;
- d) the number of test pieces tested and the length of each test piece;
- e) the test pressure and rate of pressure increase;
- f) the test medium (if other than water);
- g) the results obtained for each test piece;
- h) if the test piece fails, the position and mode of failure;
- i) any unusual features noted during the test;
- j) the date of the test.

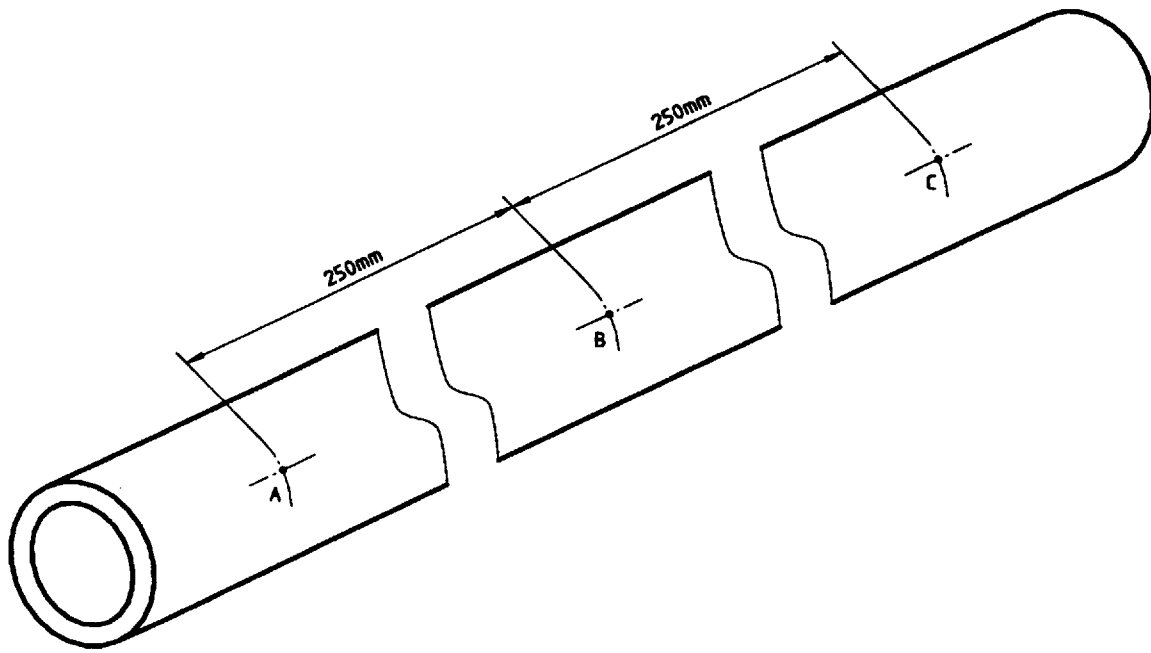

Figure 1 — Measurement of dimensional stability

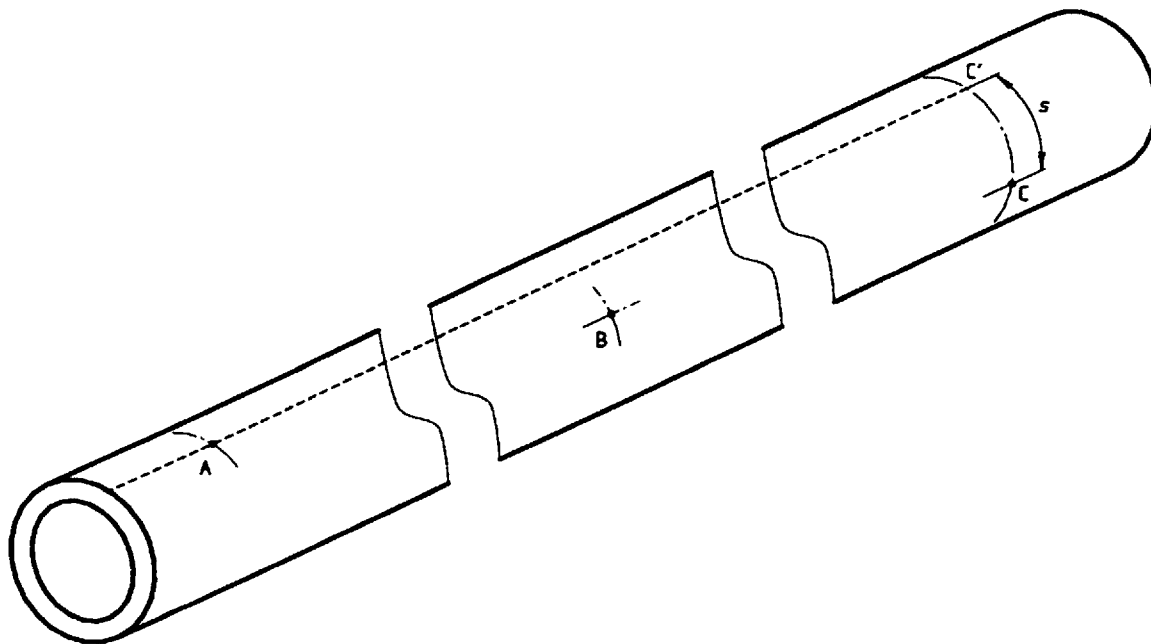

Figure 2 — Measurement of amount of twisting



S

Annex ZA (normative)**Normative references to international publications with their relevant European publications**

This European Standard incorporates by dated or undated reference, provisions from other publications. These normative references are cited at the appropriate places in the text and the publications are listed hereafter. For dated references, subsequent amendments to or revisions of any of these publications apply to this European Standard only when incorporated in it by amendment or revision. For undated references the latest edition of the publication referred to applies.

Publication	Year	Title	EN	Year
ISO 4671	1984	<i>Rubber and plastics hoses and hose assemblies — Methods of measurement of dimensions</i>	EN 24671	1993

List of references

See national foreword.



S

**BS EN ISO
1402 : 1997**

BSI — British Standards Institution

BSI is the independent national body responsible for preparing British Standards. It presents the UK view on standards in Europe and at the international level. It is incorporated by Royal Charter.

Contract requirements

A British Standard does not purport to include all the necessary provisions of a contract. Users of British Standards are responsible for their correct application.

Revisions

British Standards are updated by amendment or revision. Users of British Standards should make sure that they possess the latest amendments or editions.

It is the constant aim of BSI to improve the quality of our products and services. We would be grateful if anyone finding an inaccuracy or ambiguity while using this British Standard would inform the Secretary of the responsible technical committee, the identity of which can be found on the inside front cover. Tel: 0181 996 9000; Fax: 0181 996 7400.

BSI offers members an individual updating service called PLUS which ensures that subscribers automatically receive the latest editions of standards.

Buying standards

Orders for all BSI, international and foreign standards publications should be addressed to Customer Services, Sales Department at Chiswick: Tel: 0181 996 7000; Fax: 0181 996 7001.

In response to orders for international standards, it is BSI policy to supply the BSI implementation of those that have been published as British Standards, unless otherwise requested.

Information on standards

BSI provides a wide range of information on national, European and international standards through its Library, the Standardline Database, the BSI Information Technology Service (BITS) and its Technical Help to Exporters Service. Contact the Information Department at Chiswick: Tel: 0181 996 7111; Fax: 0181 996 7048.

Subscribing members of BSI are kept up to date with standards developments and receive substantial discounts on the purchase price of standards. For details of these and other benefits contact Customer Services, Membership at Chiswick: Tel: 0181 996 7002; Fax: 0181 996 7001.

Copyright

Copyright subsists in all BSI publications. BSI also holds the copyright, in the UK, of the publications of the international standardization bodies. Except as permitted under the Copyright, Designs and Patents Act 1988 no extract may be reproduced, stored in a retrieval system or transmitted in any form or by any means – electronic, photocopying, recording or otherwise – without prior written permission from BSI.

This does not preclude the free use, in the course of implementing the standard, of necessary details such as symbols, and size, type or grade designations. If these details are to be used for any other purpose than implementation then the prior written permission of BSI must be obtained.

If permission is granted, the terms may include royalty payments or a licensing agreement. Details and advice can be obtained from the Copyright Manager, BSI, 389 Chiswick High Road, London W4 4AL.

BSI
389 Chiswick High Road
London
W4 4AL