

Titanium dioxide pigments for paints —

Part 1: Specifications and methods of test

The European Standard EN ISO 591-1:2000 has the status of a
British Standard

ICS 87.060.10

National foreword

This British Standard is the official English language version of EN ISO 591-1:2000. It is identical with ISO 591-1:2000. It supersedes BS 1851:1978 which is withdrawn.

The UK participation in its preparation was entrusted to Technical Committee ST/1, Pigments, which has the responsibility to:

- aid enquirers to understand the text;
- present to the responsible international/European committee any enquiries on the interpretation, or proposals for change, and keep the UK interests informed;
- monitor related international and European developments and promulgate them in the UK.

A list of organizations represented on this committee can be obtained on request to its secretary.

Cross-references

Attention is drawn to the fact that CEN and CENELEC Standards normally include an annex which lists normative references to international publications with their corresponding European publications. The British Standards which implement international or European publications referred to in this document may be found in the BSI Standards Catalogue under the section entitled "International Standards Correspondence Index", or by using the "Find" facility of the BSI Standards Electronic Catalogue.

A British Standard does not purport to include all the necessary provisions of a contract. Users of British Standards are responsible for their correct application.

Compliance with a British Standard does not of itself confer immunity from legal obligations.

Summary of pages

This document comprises a front cover, an inside front cover, the EN ISO title page, the EN ISO foreword page, the ISO title page, pages ii to iv, pages 1 to 12, the annex ZA page and a back cover.

The BSI copyright notice displayed in this document indicates when the document was last issued.

Amendments issued since publication

Amd. No.	Date	Comments
13423 Corrigendum No. 1	5 October 2001	Incorporating annex ZA.

This British Standard, having been prepared under the direction of the Sector Committee for Materials and Chemicals, was published under the authority of the Standards Committee and comes into effect on 15 December 2000

© BSI 5 October 2001

ISBN 0 580 36811 4

ICS 08.006.10; 87.060.10

English version

Titanium dioxide pigments for paints - Part 1: Specifications and methods of test (ISO 591-1:2000)

Pigments de dioxyde de titane pour peintures - Partie 1:
Spécifications et méthodes d'essai (ISO 591-1:2000)

Titandioxid-Pigmente - Teil 1: Anforderungen und
Prüfverfahren (ISO 591-1:2000)

This European Standard was approved by CEN on 15 September 2000.

CEN members are bound to comply with the CEN/CENELEC Internal Regulations which stipulate the conditions for giving this European Standard the status of a national standard without any alteration. Up-to-date lists and bibliographical references concerning such national standards may be obtained on application to the Management Centre or to any CEN member.

This European Standard exists in three official versions (English, French, German). A version in any other language made by translation under the responsibility of a CEN member into its own language and notified to the Management Centre has the same status as the official versions.

CEN members are the national standards bodies of Austria, Belgium, Czech Republic, Denmark, Finland, France, Germany, Greece, Iceland, Ireland, Italy, Luxembourg, Netherlands, Norway, Portugal, Spain, Sweden, Switzerland and United Kingdom.



EUROPEAN COMMITTEE FOR STANDARDIZATION
COMITÉ EUROPÉEN DE NORMALISATION
EUROPÄISCHES KOMITEE FÜR NORMUNG

Management Centre: rue de Stassart, 36 B-1050 Brussels

CORRECTED 2001-04-11

Foreword

The text of the International Standard ISO 591-1:2000 has been prepared by Technical Committee ISO/TC 35 "Paints and varnishes" in collaboration with Technical Committee CEN/TC 298 "Pigments and extenders", the secretariat of which is held by DIN.

This European Standard shall be given the status of a national standard, either by publication of an identical text or by endorsement, at the latest by March 2001, and conflicting national standards shall be withdrawn at the latest by March 2001.

According to the CEN/CENELEC Internal Regulations, the national standards organizations of the following countries are bound to implement this European Standard: Austria, Belgium, Czech Republic, Denmark, Finland, France, Germany, Greece, Iceland, Ireland, Italy, Luxembourg, Netherlands, Norway, Portugal, Spain, Sweden, Switzerland and the United Kingdom.

Endorsement notice

The text of the International Standard ISO 591-1:2000 was approved by CEN as a European Standard without any modification.

NOTE: Normative references to International Standards are listed in annex ZA (normative).

EN ISO 591-1:2000

INTERNATIONAL STANDARD

ISO 591-1

First edition
2000-09-15

Titanium dioxide pigments for paints — Part 1: Specifications and methods of test

*Pigments de dioxyde de titane pour peintures —
Partie 1: Spécifications et méthodes d'essai*



Reference number
ISO 591-1:2000(E)

Contents

Page

Foreword..... iv

1 Scope 1

2 Normative references 1

3 Term and definition 2

4 Classification..... 2

4.1 Types..... 2

4.2 Grades..... 2

5 Required characteristics and associated tolerances 2

5.1 Appearance 2

5.2 Other characteristics..... 2

6 Sampling..... 4

7 Determination of titanium dioxide content 4

7.1 General..... 4

7.2 Method A: Aluminium reduction method 4

7.3 Method B: Chromium(II) chloride reduction method 8

8 Test report 12

Foreword

ISO (the International Organization for Standardization) is a worldwide federation of national standards bodies (ISO member bodies). The work of preparing International Standards is normally carried out through ISO technical committees. Each member body interested in a subject for which a technical committee has been established has the right to be represented on that committee. International organizations, governmental and non-governmental, in liaison with ISO, also take part in the work. ISO collaborates closely with the International Electrotechnical Commission (IEC) on all matters of electrotechnical standardization.

International Standards are drafted in accordance with the rules given in the ISO/IEC Directives, Part 3.

Draft International Standards adopted by the technical committees are circulated to the member bodies for voting. Publication as an International Standard requires approval by at least 75 % of the member bodies casting a vote.

Attention is drawn to the possibility that some of the elements of this part of ISO 591 may be the subject of patent rights. ISO shall not be held responsible for identifying any or all such patent rights.

International Standard ISO 591-1 was prepared by Technical Committee ISO/TC 35, *Paints and varnishes*, Subcommittee SC 2, *Pigments and extenders*.

This part of ISO 591 cancels and replaces ISO 591:1977, which has been technically revised. In contrast to ISO 591:1977, which specified the Nakazono reductor method for the determination of the titanium dioxide content and allowed other methods to be used by agreement between the interested parties, ISO 591-1 contains two methods (see clause 7).

ISO 591 consists of the following parts, under the general title *Titanium dioxide pigments for paints*:

- Part 1: *Specifications and methods of test*
- Part 2: *Determination of the content of secondary constituents*

Titanium dioxide pigments for paints —

Part 1: Specifications and methods of test

1 Scope

This part of ISO 591 specifies the requirements and corresponding methods of test for titanium dioxide pigments for paints.

2 Normative references

The following normative documents contain provisions which, through reference in this text, constitute provisions of this part of ISO 591. For dated references, subsequent amendments to, or revisions of, any of these publications do not apply. However, parties to agreements based on this part of ISO 591 are encouraged to investigate the possibility of applying the most recent editions of the normative documents indicated below. For undated references, the latest edition of the normative document referred to applies. Members of ISO and IEC maintain registers of currently valid International Standards.

ISO 385-1:1984, *Laboratory glassware — Burettes — Part 1: General requirements.*

ISO 648:1977, *Laboratory glassware — One-mark pipettes.*

ISO 787-1:1982, *General methods of test for pigments and extenders — Part 1: Comparison of colour of pigments.*

ISO 787-2:1981, *General methods of test for pigments and extenders — Part 2: Determination of matter volatile at 105 °C.*

ISO 787-3:2000, *General methods of test for pigments and extenders — Part 3: Determination of matter soluble in water — Hot extraction method.*

ISO 787-5:1980, *General methods of test for pigments and extenders — Part 5: Determination of oil absorption value.*

ISO 787-9:1981, *General methods of test for pigments and extenders — Part 9: Determination of pH value of an aqueous suspension.*

ISO 787-14:1973, *General methods of test for pigments — Part 14: Determination of resistivity of aqueous extract.*

ISO 787-18:1983, *General methods of test for pigments and extenders — Part 18: Determination of residue on sieve — Mechanical flushing procedure.*

ISO 787-24:1985, *General methods of test for pigments and extenders — Part 24: Determination of relative tinting strength of coloured pigments and relative scattering power of white pigments — Photometric methods.*

ISO 787-25:1993, *General methods of test for pigments and extenders — Part 25: Comparison of the colour, in full-shade systems, of white, black and coloured pigments — Colorimetric method.*

EN ISO 591-1:2000

ISO 1042:1998, *Laboratory glassware — One-mark volumetric flasks.*

ISO 3696:1987, *Water for analytical laboratory use — Specification and test methods.*

ISO 15528:2000, *Paints, varnishes and raw materials for paints and varnishes — Sampling.*

3 Term and definition

For the purposes of this part of ISO 591, the following term and definition apply.

3.1

titanium dioxide pigment

pigment consisting essentially of titanium dioxide (TiO₂) of the anatase or the rutile crystal structure, as determined by X-ray examination

4 Classification

4.1 Types

This part of ISO 591 covers two types of titanium dioxide pigment, as follows:

Type A: Anatase type

Type R: Rutile type

4.2 Grades

The pigments are further classified into the following grades:

Grade A1	}	Type A
Grade A2		

Grade R1	}	Type R
Grade R2		
Grade R3		

5 Required characteristics and associated tolerances

5.1 Appearance

The material shall be in the form of a soft, dry powder or in such a condition that it may be readily reduced thereto by crushing under a palette knife, without any grinding action.

5.2 Other characteristics

5.2.1 For titanium dioxide pigments complying with this part of ISO 591, the essential requirements are specified in Table 1 and the conditional requirements are listed in Table 2. The conditional requirements shall be specified by agreement between the interested parties.

The requirement for matter volatile at 105 °C after preconditioning in Table 2 shall only apply if this characteristic is explicitly specified by the interested parties or in a contract.

5.2.2 The agreed reference pigment referred to in Table 2 shall comply with the requirements of Table 1.

Table 1 — Essential requirements

Characteristic	Requirement depending on type and grade					Method of test
	Type A		Type R			
	A1	A2	R1	R2	R3	
Titanium dioxide content % (by mass), min.	98	92	97	90	80	See clause 7
Matter volatile at 105 °C at point of acceptance % (by mass), max.	0,5	0,8	0,5	To be agreed between the interested parties		ISO 787-2
Matter soluble in water % (by mass), max.	0,6	0,5	0,6	0,5	0,7	ISO 787-3 ^a
Residue on sieve (45 µm) % (by mass), max.	0,1	0,1	0,1	0,1	0,1	ISO 787-18 or other agreed method

^a If necessary, a coagulation agent may be used.

Table 2 — Conditional requirements

Characteristic	Requirement depending on type and grade					Method of test
	Type A		Type R			
	A1	A2	R1	R2	R3	
Colour	Similar to that of the agreed reference pigment (see 5.2.2)					ISO 787-1 or ISO 787-25 ^a
Scattering power	To be agreed between the interested parties					ISO 787-24
Matter volatile at 105 °C after 24 h preconditioning at (23 ± 2) °C and (50 ± 5) % relative humidity % (by mass), max. ^b	0,5	0,8	0,5	1,5	2,5	ISO 787-2
pH of aqueous suspension	Similar to that of the agreed reference pigment (see 5.2.2)					ISO 787-9
Oil absorption value						
Resistivity of aqueous extract	—	Similar to that of the agreed reference pigment (see 5.2.2)	—	Similar to that of the agreed reference pigment (see 5.2.2)		ISO 787-14

^a By agreement only.
^b See 5.2.1.

6 Sampling

Take a representative sample of the product to be tested, as described in ISO 15528.

7 Determination of titanium dioxide content

7.1 General

For the determination of the titanium dioxide content, two methods (A and B) are provided. In cases of dispute, either of the methods may be used as the referee method, by agreement between the interested parties.

Method A uses aluminium metal as the reducing agent. It is suitable for individual determinations and for routine analysis.

Method B uses chromium(II) chloride and zinc amalgam as reducing agents and can be automated. It is particularly suitable as a routine method.

7.2 Method A: Aluminium reduction method

7.2.1 Principle

A test portion of the dried sample is dissolved in sulfuric acid, with the addition of ammonium sulfate. The titanium(IV) is then reduced to titanium(III) with aluminium under a carbon dioxide atmosphere. The solution is then titrated with ammonium iron(III) sulfate, using ammonium thiocyanate as indicator.

7.2.2 Reagents

During the analysis, use only reagents of recognized analytical grade and only water of at least grade 3 purity as defined in ISO 3696.

WARNING — Use the reagents in accordance with the appropriate health and safety regulations.

7.2.2.1 Hydrochloric acid, concentrated, approximately 37 % (by mass), $\rho \approx 1,19$ g/ml.

7.2.2.2 Sulfuric acid, concentrated, approximately 96 % (by mass), $\rho \approx 1,84$ g/ml.

7.2.2.3 Ammonium sulfate.

7.2.2.4 Sodium hydrogen carbonate, saturated solution.

Prepare this solution at the time of use. About 10 g of sodium hydrogen carbonate (NaHCO_3) to 90 ml of water are required.

7.2.2.5 Ammonium thiocyanate indicator.

Dissolve 24,5 g of ammonium thiocyanate (NH_4SCN) in 80 ml of hot water, filter, cool to room temperature and dilute to 100 ml. Keep in a well-stoppered, dark-coloured bottle.

7.2.2.6 Ammonium iron(III) sulfate, standard volumetric solution, 1 ml equivalent to 0,0048 g of TiO_2 .

7.2.2.6.1 Preparation

Dissolve, in a 1 000 ml one-mark volumetric flask, 30 g of freshly prepared ammonium iron(III) sulfate [$(\text{FeNH}_4(\text{SO}_4)_2 \cdot 12\text{H}_2\text{O})$] in 300 ml of water containing 15 ml of sulfuric acid (7.2.2.2). Add potassium permanganate solution (7.2.2.7), drop by drop, until the solution is pink coloured. Dilute to the mark with water and mix well. Filter if the solution is cloudy.

7.2.2.6.2 Standardization

Standardize the solution using 190 mg to 210 mg of titanium dioxide reference standard, dried to constant mass at (105 ± 2) °C, following the procedure described in 7.2.4.3.

Calculate the titanium dioxide equivalent T_1 of the solution, expressed in grams of TiO_2 per millilitre, using the equation

$$T_1 = \frac{m_1 \times P}{V_1 \times 100}$$

where

m_1 is the mass, in grams, of reference standard used;

P is the titanium dioxide content of the reference standard, expressed as a percentage by mass (i.e. 99,74 %);

V_1 is the volume, in millilitres, of the ammonium iron(III) sulfate solution required in the titration.

7.2.2.7 Potassium permanganate, standard volumetric solution, $c(\frac{1}{5} \text{KMnO}_4) = 0,1$ mol/l.

Dissolve 3,1607 g of potassium permanganate in 500 ml of water in a 1 000 ml one-mark volumetric flask, dilute to the mark with water and mix well.

7.2.2.8 Aluminium metal, electrolytic grade, for example in the form of foil, sheet or cut wire.

7.2.3 Apparatus

Use ordinary laboratory apparatus and burettes, pipettes and one-mark volumetric flasks complying with the requirements of ISO 385-1, ISO 648 and ISO 1042, respectively, together with the following:

7.2.3.1 Delivery tube: an essentially U-shaped glass tube, 4 mm in internal diameter, comprising a horizontal section and two vertical arms, one of the vertical arms being 150 mm long and the other 75 mm long.

As an alternative, an absorption apparatus as shown in Figure 1 or a Contat-Göckel cap as shown in Figure 2 may be used.

7.2.3.2 Weighing bottle, wide-mouth, with an external-fitting cap, and no larger than necessary for the test portion.

7.2.3.3 Oven, capable of maintaining a temperature of (105 ± 2) °C.

7.2.3.4 Desiccator, containing a suitable desiccant, for example silica gel.

7.2.4 Procedure

7.2.4.1 General

Carry out the determination in duplicate.

7.2.4.2 Test portion

Take about 10 g of the sample (see clause 6) and dry it in the open weighing bottle (7.2.3.2) at (105 ± 2) °C to constant mass. Cap the bottle and allow it to cool to room temperature in the desiccator (7.2.3.4).

Weigh out, to the nearest 0,1 mg, 190 mg to 210 mg of this test sample (m_2).

Dimensions in millimetres

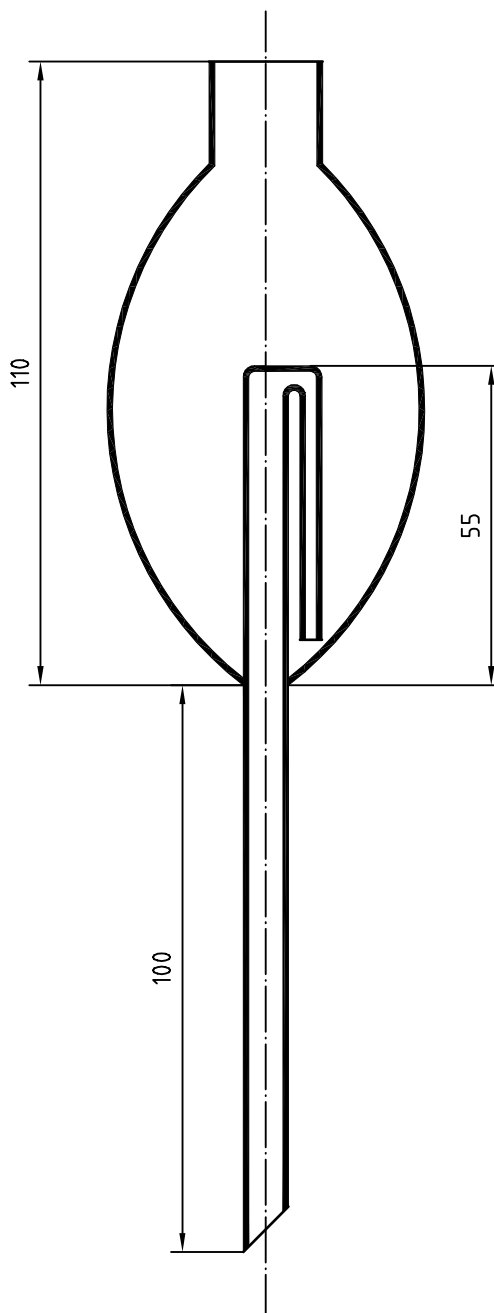
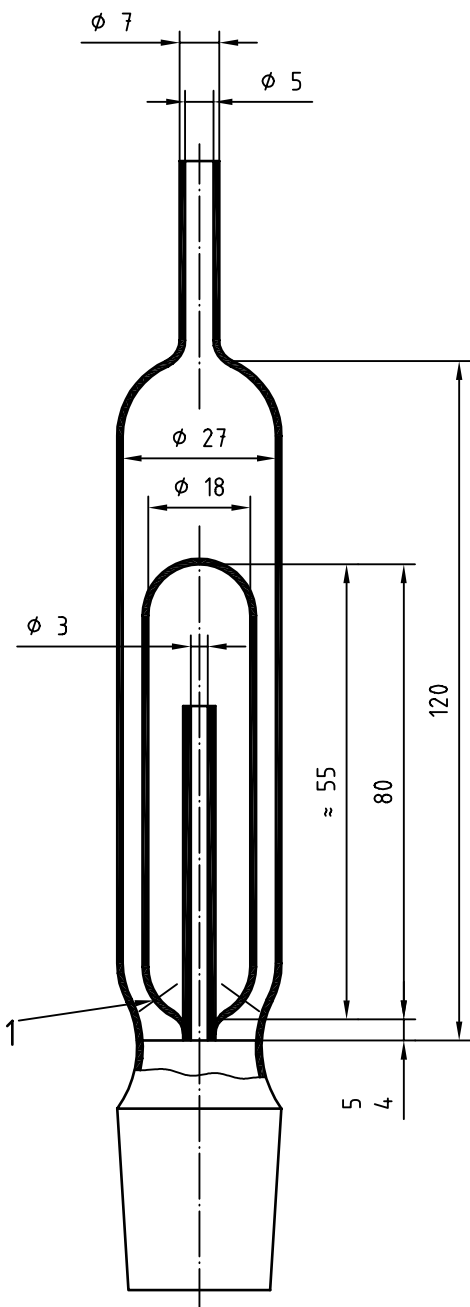

Key

- 1 Four openings (\varnothing 1 mm to 2 mm)

Figure 1 — Possible absorption apparatus

Figure 2 — Possible absorption apparatus (Contat-Göckel cap)

7.2.4.3 Determination

Transfer the test portion to a dry, wide-necked 500 ml conical flask. Add 7 g to 8 g of ammonium sulfate (7.2.2.3) and 20 ml of sulfuric acid (7.2.2.2). Mix well and heat on a hotplate until dense white fumes are evolved. Continue heating strongly until dissolution is complete (usually requires max. 5 min of boiling) or until it is apparent that the residue is composed of SiO₂ or siliceous matter. Cool and, with caution, add 120 ml of water and 20 ml of hydrochloric acid (7.2.2.1). Bring to the boil again and then remove from the heat.

Insert the short arm of the delivery tube (7.2.3.1) into a hole in a rubber stopper which fits the conical flask, or use an absorption apparatus. Place approximately 1 g of aluminium metal (7.2.2.8) in the flask. Ensure that the end of the long arm of the delivery tube is near the bottom of a 250 ml beaker containing about 150 ml of sodium hydrogen carbonate solution (7.2.2.4), or place the solution in the absorption apparatus.

As soon as the dissolution of the aluminium is complete, heat the contents of the flask to gentle boiling for 3 min to 5 min without removing the delivery tube from the sodium hydrogen carbonate solution. Cool to about 60 °C, preferably by partial immersion of the flask in a vessel of water. The sodium hydrogen carbonate solution should siphon into the flask during this cooling, giving an atmosphere of carbon dioxide over the reduced titanium solution. Withdraw the stopper, and rinse the stopper and the delivery tube with a little water, collecting the rinse water in the flask before removing the stopper and delivery tube completely.

Add 2 ml of ammonium thiocyanate indicator solution (7.2.2.5) and titrate immediately with ammonium iron(III) sulfate solution (7.2.2.6) to a pink-coloured endpoint. It is best to add the bulk of the ammonium iron(III) sulfate solution at once, shake well, and finish the titration drop by drop. Record the volume of ammonium iron(III) sulfate solution used (V_2).

7.2.5 Expression of results

7.2.5.1 Calculation

Calculate the titanium dioxide content $w(\text{TiO}_2)$, expressed as a percentage by mass, using the equation

$$w(\text{TiO}_2) = \frac{V_2 \times T_1 \times 100}{m_2}$$

where

m_2 is the mass, in grams, of the test portion, dried to constant mass;

V_2 is the volume, in millilitres, of the ammonium iron(III) sulfate solution (7.2.2.6) used in the determination;

T_1 is the titanium dioxide equivalent, in grams per millilitre, of the ammonium iron(III) sulfate solution (see 7.2.2.6.2).

Calculate the mean of the two determinations and report the result to the nearest 0,1 % (by mass).

NOTE The calculated results include chromium, arsenic and any other substance that is reduced by aluminium and subsequently oxidized by iron(III). However, appreciable quantities of interfering materials are not likely to be encountered in the titanium dioxide pigments usually used in paints and related products.

7.2.5.2 Precision

No precision data are currently available.

7.3 Method B: Chromium(II) chloride reduction method

7.3.1 Principle

A test portion of the dried sample is heated with molten potassium pyrosulfate, and the melt is dissolved in hydrochloric acid. The titanium(IV) is then reduced to titanium(III) with chromium(II) chloride solution under a carbon dioxide atmosphere. The solution is then titrated with potassium dichromate, using potentiometric indication of the endpoint.

7.3.2 Reagents

During the analysis, use only reagents of recognized analytical grade and only water of at least grade 3 purity as defined in ISO 3696.

WARNING — Use the reagents in accordance with the appropriate health and safety regulations.

7.3.2.1 Hydrochloric acid, concentrated, approximately 37 % (by mass), $\rho \approx 1,19$ g/ml.

7.3.2.2 Sulfuric acid, concentrated, approximately 96 % (by mass), $\rho \approx 1,84$ g/ml.

7.3.2.3 Sulfuric acid, dilute, approximately 5 % (by mass).

7.3.2.4 Potassium pyrosulfate ($K_2S_2O_7$), fine powder.

7.3.2.5 Chromium(III) chloride¹⁾, solution, $c(\text{CrCl}_3 \cdot 6\text{H}_2\text{O}) = 0,3$ mol/l.

Dissolve, in a 1 000 ml one-mark volumetric flask, 79,93 g of chromium(III) chloride hexahydrate, $\text{CrCl}_3 \cdot 6\text{H}_2\text{O}$, in 300 ml of water containing 100 ml of hydrochloric acid (7.3.2.1). Dilute to the mark with water and mix well.

7.3.2.6 Chromium(II) chloride, solution, $c(\text{CrCl}_2) = 0,3$ mol/l, prepared by reduction of chromium(III) chloride with zinc amalgam, as follows:



7.3.2.6.1 Precautions

7.3.2.6.1.1 As zinc amalgam is stored in dilute sulfuric acid, it is very important to separate the amalgam from the solution to avoid dilution of the chromium(II) chloride solution to be prepared. Transfer the zinc amalgam as described in 7.3.2.6.2.1.

7.3.2.6.1.2 Store the chromium(II) chloride solution obtained in a brown glass bottle under petroleum ether to minimize oxidation. Ensure that all precautions are taken to preserve the solution from oxidation by always operating in an inert atmosphere (carbon dioxide).

Chromium(II) chloride solutions are unstable. Prepare a fresh solution each day.

1) Information on suppliers of chromium(III) chloride can be obtained through the Secretariat of ISO/TC 35/SC 2, c/o DIN Deutsches Institut für Normung e.V., Burggrafstraße 6, D-10787 Berlin.

7.3.2.6.2 Preparation

7.3.2.6.2.1 Transfer of zinc amalgam to the reductor

Transfer the zinc amalgam (7.3.2.8) to a separator (Nakazono reductor or separating funnel). Separate the amalgam at the base of the separator from the sulfuric acid (in beaker 1 amalgam only, in beaker 2 sulfuric acid). Transfer the amalgam in beaker 1 to the reductor.

7.3.2.6.2.2 Reduction of chromium(III) to chromium(II)

Pour approximately 200 ml of chromium(III) chloride solution (7.3.2.5) into a beaker. Heat the solution to 60 °C. Pour the hot solution into the reductor. Flush with carbon dioxide for 3 min. Close the stopcock connecting the reduction vessel with the atmosphere, then close the stopcock supplying carbon dioxide to the reductor so that the contents of the apparatus remain under an inert atmosphere. Shake the solution for 5 min (the colour of the solution, green at the beginning, changes to intense blue when reduced).

7.3.2.6.2.3 Transfer to the titration flask

Transfer the solution to a brown glass titration flask containing petroleum ether, using the following procedure. Pass carbon dioxide into the reductor by opening the upper stopcock and leaving it open during the following operations. Attach one end of a length of tubing to the base of the reductor. Open the lower stopcock of the reductor and recover the amalgam in a vessel containing dilute sulfuric acid (7.3.2.3). Then, with the other end of the tubing under the petroleum ether layer, transfer the solution to the titration flask.

7.3.2.7 Potassium dichromate, standard volumetric solution, $c(\frac{1}{6} \text{K}_2\text{Cr}_2\text{O}_7) = 0,06 \text{ mol/l}$, 1 ml equivalent to 0,0048 g of TiO_2 .

7.3.2.7.1 Preparation

Dry a sufficient quantity of $\text{K}_2\text{Cr}_2\text{O}_7$ in an oven at $(105 \pm 2) \text{ }^\circ\text{C}$ to constant mass. Allow to cool in a desiccator. Weigh out 2,9418 g of the dried potassium dichromate to the nearest 0,1 mg. Transfer to a 1000 ml one-mark volumetric flask, dissolve in water, dilute to the mark with water and mix well.

7.3.2.7.2 Standardization

Standardize the solution using the titanium dioxide reference standard, dried to constant mass at $(105 \pm 2) \text{ }^\circ\text{C}$, following the procedure described in 7.3.4.3. Prepare four separate solutions and calculate the titanium dioxide equivalent T_2 of the solution, expressed in grams of TiO_2 per millilitre, using the following equation:

$$T_2 = \frac{m_1 \times P}{(V_2 - V_1) \times 100}$$

where

m_1 is the mass, in grams, of reference standard used;

P is the titanium dioxide content of the reference standard, expressed as a percentage by mass (i.e. 99,74 %);

V_1 is the volume, in millilitres, of potassium dichromate solution (7.3.2.7) required to oxidize the excess chromium(II) chloride;

V_2 is the volume, in millilitres, of potassium dichromate solution (7.3.2.7) required to oxidize the excess chromium(II) chloride plus the reduced titanium.

7.3.2.8 Zinc amalgam, 3 % (by mass).

WARNING — Mercury is toxic. Avoid skin contact and inhalation of vapour. Carry out all procedures in a well-ventilated fume cupboard.

Place 50 ml of mercury in a porcelain dish on a steam bath in a fume cupboard. Cover the surface of the mercury with dilute sulfuric acid (7.3.2.3). Add 20 g to 30 g of zinc in small granules. Stir from time to time and replenish the dilute acid with water as required. When all the solid zinc has disappeared, allow the amalgam to cool and stand for several hours. Finally, filter through a Gooch crucible with no filter pad. Keep the amalgam in a small bottle under dilute sulfuric acid (7.3.2.3).

7.3.2.9 Carbon dioxide, in a steel cylinder.

7.3.3 Apparatus

Use ordinary laboratory apparatus and burettes, pipettes and one-mark volumetric flasks complying with the requirements of ISO 385-1, ISO 648 or ISO 1042, respectively, together with the following:

7.3.3.1 Nakazono reductor or separating funnel.

7.3.3.2 Weighing bottle, wide-mouth, with an external-fitting cap, and no larger than necessary for the test portion.

7.3.3.3 Oven, capable of maintaining a temperature of (105 ± 2) °C.

7.3.3.4 Desiccator, containing a suitable desiccant, for example silica gel.

7.3.3.5 Silica flask, capacity 250 ml.

7.3.3.6 Meker burner, burning a gas/oxygen mixture.

7.3.3.7 Automatic titrator, with a microprocessor for endpoint determination.

7.3.3.8 Gold-wire indicator electrode.

7.3.3.9 Calomel reference electrode.

7.3.3.10 Hotplate, capable of being maintained at a constant temperature of 60 °C.

7.3.3.11 Stirrer.

7.3.4 Procedure

7.3.4.1 General

Carry out the determination in duplicate.

7.3.4.2 Test portion

Take about 10 g of the sample (see clause 6) and dry it in the open weighing bottle (7.3.3.2) at (105 ± 2) °C to constant mass. Cap the bottle and allow it to cool to room temperature in the desiccator.

Weigh out, to the nearest 0,1 mg, 0,5 g of this test sample (m_3).

7.3.4.3 Determination

Fuse (25 ± 1) g of potassium pyrosulfate (7.3.2.4) in the silica flask (7.3.3.5) and continue to heat until fuming ceases. Allow to cool.

Transfer the test portion to the flask containing the fused potassium pyrosulfate. Gently heat the flask for 5 min, then raise the heat, gradually to avoid spattering, followed by heating in the full flame of the Meker burner (7.3.3.6). Swirl from time to time until a clear melt is obtained. Allow to cool.

Add 50 ml of hydrochloric acid (7.3.2.1) and 100 ml of water. Heat until the solution is clear. Allow the solution to cool. Make up to 500 ml with water in a one-mark volumetric flask and mix well. Pipette 50 ml of this solution into a brown glass titration flask. Add 5 ml of hydrochloric acid (7.3.2.1) and 100 ml of dilute sulfuric acid (7.3.2.3). Heat on the hotplate (7.3.3.10) to constant temperature (60 °C). Insert the electrodes (7.3.3.8 and 7.3.3.9), the stirrer (7.3.3.11) and a carbon dioxide diffuser. Place under a burette filled with potassium dichromate solution (7.3.2.7). Start up the stirrer and the carbon dioxide flow and set at an appropriate rate. Transfer about 4 ml of chromium(II) chloride solution (7.3.2.6) to the titration flask (see 7.3.2.6.2.3) and begin to titrate with potassium dichromate solution. Determine the volumes V_3 and V_4 (see 7.3.4.4 and 7.3.5.1).

7.3.4.4 Titration curve

Chromium(II) chloride is used to reduce Ti^{4+} to Ti^{3+} . Generally, the potential obtained after reduction of Ti^{4+} is about -400 mV to -300 mV relative to the calomel electrode.

Two changes are observed in the titration curve, the first corresponding to the oxidation of the excess chromium(II) chloride, the second to the oxidation of the reduced titanium. The normal redox potentials for these reactions are as follows:



Reduction of the dichromate takes place as follows:

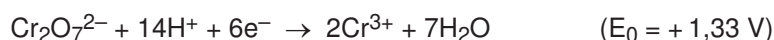

7.3.4.5 Interference

Antimony at a content higher than 0,2 % (by mass) of Sb_2O_3 will lead to a higher value for the TiO_2 content.

7.3.5 Expression of results

7.3.5.1 Calculation

Calculate the titanium dioxide content $w(TiO_2)$, expressed as a percentage by mass, using the equation

$$w(TiO_2) = \frac{(V_4 - V_3) \times T_2 \times 100}{m_3}$$

where

m_3 is the mass, in grams, of the test portion;

V_3 is the volume, in millilitres, of potassium dichromate solution (7.3.2.7), required to oxidize the excess chromium(II) chloride;

V_4 is the volume, in millilitres, of potassium dichromate solution (7.3.2.7), required to oxidize the excess chromium(II) chloride plus the reduced titanium;

T_2 is the titanium dioxide equivalent, in grams per millilitre, of the potassium dichromate solution (see 7.3.2.7.2).

7.3.5.2 Precision

No precision data are currently available.

8 Test report

The test report shall contain at least the following information:

- a) a reference to this part of ISO 591 (ISO 591-1);
- b) all details necessary to identify the product tested;
- c) the results of the test, the method used where a choice is available, and whether or not the product complies with the relevant specification limits;
- d) any deviation from the method of test specified;
- e) the date of the test.

Annex ZA (normative)**Normative references to international publications with their relevant European publications**

This European Standard incorporates by dated or undated reference, provisions from other publications. These normative references are cited at the appropriate places in the text and the publications are listed hereafter. For dated references, subsequent amendments to or revisions of any of these publications apply to this European Standard only when incorporated in it by amendment or revision. For undated references the latest edition of the publication referred to applies (including amendments).

NOTE Where an International Publication has been modified by common modifications, indicated by (mod.), the relevant EN/HD applies.

<u>Publication</u>	<u>Year</u>	<u>Title</u>	<u>EN</u>	<u>Year</u>
ISO 787-2	1981	General methods of test for pigments and extenders - Part 2: Determination of matter volatile at 105 degrees C	EN ISO 787-2	1995
ISO 787-3	2000	General methods of test for pigments and extenders - Part 3: Determination of matter soluble in water - Hot extraction method	EN ISO 787-3	2000
ISO 787-5	1980	General methods of test for pigments and extenders - Part 5: Determination of oil absorption value	EN ISO 787-5	1995
ISO 787-9	1981	General methods of test for pigments and extenders - Part 9: Determination of pH value of aqueous suspension	EN ISO 787-9	1995
ISO 787-18	1983	General methods of test for pigments and extenders - Part 18: Determination of residue on sieve - Mechanical flushing procedure	EN ISO 787-18	1995
ISO 787-24	1995	General method of tests for pigments and extenders - Part 24: Determination of relative tinting strength of coloured pigments and relative scattering power of white pigments - Photometric methods	EN ISO 787-24	1995
ISO 1042	1998	Laboratory glassware - One-mark volumetric flasks	EN ISO 1042	1999
ISO 3696	1987	Water for analytical laboratory use - Specification and test methods	EN ISO 3696	1995

BSI — British Standards Institution

BSI is the independent national body responsible for preparing British Standards. It presents the UK view on standards in Europe and at the international level. It is incorporated by Royal Charter.

Revisions

British Standards are updated by amendment or revision. Users of British Standards should make sure that they possess the latest amendments or editions.

It is the constant aim of BSI to improve the quality of our products and services. We would be grateful if anyone finding an inaccuracy or ambiguity while using this British Standard would inform the Secretary of the technical committee responsible, the identity of which can be found on the inside front cover. Tel: 020 8996 9000. Fax: 020 8996 7400.

BSI offers members an individual updating service called PLUS which ensures that subscribers automatically receive the latest editions of standards.

Buying standards

Orders for all BSI, international and foreign standards publications should be addressed to Customer Services. Tel: 020 8996 9001. Fax: 020 8996 7001. Standards are also available from the BSI website at <http://www.bsi-global.com>.

In response to orders for international standards, it is BSI policy to supply the BSI implementation of those that have been published as British Standards, unless otherwise requested.

Information on standards

BSI provides a wide range of information on national, European and international standards through its Library and its Technical Help to Exporters Service. Various BSI electronic information services are also available which give details on all its products and services. Contact the Information Centre. Tel: 020 8996 7111. Fax: 020 8996 7048.

Subscribing members of BSI are kept up to date with standards developments and receive substantial discounts on the purchase price of standards. For details of these and other benefits contact Membership Administration. Tel: 020 8996 7002. Fax: 020 8996 7001. Further information about BSI is available on the BSI website at <http://www.bsi-global.com>.

Copyright

Copyright subsists in all BSI publications. BSI also holds the copyright, in the UK, of the publications of the international standardization bodies. Except as permitted under the Copyright, Designs and Patents Act 1988 no extract may be reproduced, stored in a retrieval system or transmitted in any form or by any means – electronic, photocopying, recording or otherwise – without prior written permission from BSI.

This does not preclude the free use, in the course of implementing the standard, of necessary details such as symbols, and size, type or grade designations. If these details are to be used for any other purpose than implementation then the prior written permission of BSI must be obtained.

If permission is granted, the terms may include royalty payments or a licensing agreement. Details and advice can be obtained from the Copyright Manager. Tel: 020 8996 7070.