

# Acoustics — Reference zero for the calibration of audiometric equipment —

**Part 5: Reference equivalent threshold  
sound pressure levels for pure tones in  
the frequency range 8 kHz to 16 kHz**

The European Standard EN ISO 389-5:2006 has the status of a  
British Standard

ICS 13.140

## National foreword

This British Standard was published by BSI. It is the UK implementation of EN ISO 389-5:2006. It supersedes BS EN ISO 389-5:2001 which is withdrawn.

The UK participation in its preparation was entrusted by Technical Committee EH/1, Acoustics, to Subcommittee EH/1/1, Hearing.

A list of organizations represented on EH/1/1 can be obtained on request to its secretary.

This publication does not purport to include all the necessary provisions of a contract. Users are responsible for its correct application.

**Compliance with a British Standard cannot confer immunity from legal obligations.**

This British Standard was published under the authority of the Standards Policy and Strategy Committee on 28 February 2007

© BSI 2007

ISBN 978 0 580 50294 1

### Amendments issued since publication

Amd. No.	Date	Comments

English Version

Acoustics - Reference zero for the calibration of audiometric equipment - Part 5: Reference equivalent threshold sound pressure levels for pure tones in the frequency range 8 kHz to 16 kHz (ISO 389-5:2006)

Acoustique - Zéro de référence pour l'étalonnage d'équipements audiométriques - Partie 5: Niveaux de référence équivalents de pression acoustique liminaire pour les sons purs dans le domaine de fréquences de 8 kHz à 16 kHz (ISO 389-5:2006)

Akustik - Standard-Bezugspegel für die Kalibrierung audiometrischer Geräte - Teil 5: Äquivalente Bezugs-Schwellenschalldruckpegel für reine Töne im Frequenzbereich 8 kHz bis 16 kHz (ISO 389-5:2006)

This European Standard was approved by CEN on 6 November 2006.

CEN members are bound to comply with the CEN/CENELEC Internal Regulations which stipulate the conditions for giving this European Standard the status of a national standard without any alteration. Up-to-date lists and bibliographical references concerning such national standards may be obtained on application to the Central Secretariat or to any CEN member.

This European Standard exists in three official versions (English, French, German). A version in any other language made by translation under the responsibility of a CEN member into its own language and notified to the Central Secretariat has the same status as the official versions.

CEN members are the national standards bodies of Austria, Belgium, Cyprus, Czech Republic, Denmark, Estonia, Finland, France, Germany, Greece, Hungary, Iceland, Ireland, Italy, Latvia, Lithuania, Luxembourg, Malta, Netherlands, Norway, Poland, Portugal, Romania, Slovakia, Slovenia, Spain, Sweden, Switzerland and United Kingdom.



EUROPEAN COMMITTEE FOR STANDARDIZATION  
COMITÉ EUROPÉEN DE NORMALISATION  
EUROPÄISCHES KOMITEE FÜR NORMUNG

Management Centre: rue de Stassart, 36 B-1050 Brussels

## Foreword

This document (EN ISO 389-5:2006) has been prepared by Technical Committee ISO/TC 43 "Acoustics" in collaboration with Technical Committee CEN/TC 211 "Acoustics", the secretariat of which is held by DS.

This European Standard shall be given the status of a national standard, either by publication of an identical text or by endorsement, at the latest by May 2007, and conflicting national standards shall be withdrawn at the latest by May 2007.

This document supersedes EN ISO 389-5:1999.

According to the CEN/CENELEC Internal Regulations, the national standards organizations of the following countries are bound to implement this European Standard: Austria, Belgium, Cyprus, Czech Republic, Denmark, Estonia, Finland, France, Germany, Greece, Hungary, Iceland, Ireland, Italy, Latvia, Lithuania, Luxembourg, Malta, Netherlands, Norway, Poland, Portugal, Romania, Slovakia, Slovenia, Spain, Sweden, Switzerland and United Kingdom.

### Endorsement notice

The text of ISO 389-5:2006 has been approved by CEN as EN ISO 389-5:2006 without any modifications.

INTERNATIONAL  
STANDARD

**ISO**  
**389-5**

First edition  
2006-11-15

---

---

**Acoustics — Reference zero for the  
calibration of audiometric equipment —**

Part 5:

**Reference equivalent threshold sound  
pressure levels for pure tones in the  
frequency range 8 kHz to 16 kHz**

*Acoustique — Zéro de référence pour l'étalonnage d'équipements  
audiométriques —*

*Partie 5: Niveaux de référence équivalents de pression acoustique  
liminaire pour les sons purs dans le domaine de fréquences de 8 kHz à  
16 kHz*



Reference number  
ISO 389-5:2006(E)

1  
2

3

4

5

6

7

<b>Contents</b>	<b>Page</b>
<b>Foreword</b> .....	<b>iv</b>
<b>Introduction</b> .....	<b>v</b>
<b>1 Scope</b> .....	<b>1</b>
<b>2 Normative references</b> .....	<b>1</b>
<b>3 Terms and definitions</b> .....	<b>1</b>
<b>4 Specifications</b> .....	<b>2</b>
<b>Annex A</b> (informative) <b>Notes on the derivation of the reference equivalent threshold sound pressure levels for audiometric earphones in the frequency range from 8 kHz to 16 kHz</b> .....	<b>3</b>
<b>Annex B</b> (informative) <b>RETSPL values for Koss HV/1A</b> .....	<b>4</b>
<b>Bibliography</b> .....	<b>6</b>

## Foreword

ISO (the International Organization for Standardization) is a worldwide federation of national standards bodies (ISO member bodies). The work of preparing International Standards is normally carried out through ISO technical committees. Each member body interested in a subject for which a technical committee has been established has the right to be represented on that committee. International organizations, governmental and non-governmental, in liaison with ISO, also take part in the work. ISO collaborates closely with the International Electrotechnical Commission (IEC) on all matters of electrotechnical standardization.

International Standards are drafted in accordance with the rules given in the ISO/IEC Directives, Part 2.

The main task of technical committees is to prepare International Standards. Draft International Standards adopted by the technical committees are circulated to the member bodies for voting. Publication as an International Standard requires approval by at least 75 % of the member bodies casting a vote.

Attention is drawn to the possibility that some of the elements of this document may be the subject of patent rights. ISO shall not be held responsible for identifying any or all such patent rights.

ISO 389-5 was prepared by Technical Committee ISO/TC 43, *Acoustics*.

This first edition of ISO 389-5 cancels and replaces ISO/TR 389-5:1998, which has been technically revised.

ISO 389 consists of the following parts, under the general title *Acoustics — Reference zero for the calibration of audiometric equipment*:

- *Part 1: Reference equivalent threshold sound pressure levels for pure tones and supra-aural earphones*
- *Part 2: Reference equivalent threshold sound pressure levels for pure tones and insert earphones*
- *Part 3: Reference equivalent threshold force levels for pure tones and bone vibrators*
- *Part 4: Reference levels for narrow-band masking noise*
- *Part 5: Reference equivalent threshold sound pressure levels for pure tones in the frequency range 8 kHz to 16 kHz*
- *Part 6: Reference hearing threshold levels for test signals of short duration*
- *Part 7: Reference threshold of hearing under free-field and diffuse-field listening conditions*
- *Part 8: Reference equivalent threshold sound pressure levels for pure tones and circumaural earphones*

A part 9, dealing with the preferred test conditions for the determination of reference hearing threshold levels is under development.



## Introduction

An International Standard for extended high frequency audiometers has already been published as IEC 60645-4. Adaptors to be used with the IEC 60318-1 ear simulator to provide an interim acoustic coupler for the calibration of circumaural audiometric earphones in the extended high frequency range presently are standardized in IEC 60318-2 (to be included in a revised IEC 60318-1). The reference equivalent threshold sound pressure levels for specific circumaural and insert earphones described in this International Standard enable calibration of those audiometers which are equipped with these earphones, in order to promote agreement and uniformity in the expression of hearing threshold level measurements worldwide.

Annexes A and B of this part of ISO 389 are for information only. A Bibliography is given at the end of this International Standard.



# Acoustics — Reference zero for the calibration of audiometric equipment —

## Part 5:

# Reference equivalent threshold sound pressure levels for pure tones in the frequency range 8 kHz to 16 kHz

## 1 Scope

This part of ISO 389 specifies reference equivalent threshold sound pressure levels (RETSPLs) of pure tones in the frequency range from 8 kHz to 16 kHz applicable to the calibration of air conduction audiometers for specific earphones.

NOTE Some notes and references on the derivation and the test conditions used to determine the reference levels are given in Annex A and the Bibliography.

## 2 Normative references

The following referenced documents are indispensable for the application of this document. For dated references, only the edition cited applies. For undated references, the latest edition of the referenced document (including any amendments) applies.

ISO 389-1, *Acoustics — Reference zero for the calibration of audiometric equipment — Part 1: Reference equivalent threshold sound pressure levels for pure tones and supra-aural earphones*

ISO 389-2:1994, *Acoustics — Reference zero for the calibration of audiometric equipment — Part 2: Reference equivalent threshold sound pressure levels for pure tones and insert earphones*

IEC 60318-1<sup>1)</sup>, *Electroacoustics — Simulators for human head and ear — Part 1: Ear simulator for the calibration of supra-aural and circumaural earphones*

IEC 60318-2:1998<sup>2)</sup>, *Electroacoustics — Simulators for human head and ear — Part 2: An interim acoustic coupler for the calibration of audiometric earphones in the extended high-frequency range*

IEC 60711<sup>3)</sup>, *Occluded-ear simulator for the measurement of earphones coupled to the ear by ear inserts*

## 3 Terms and definitions

For the purposes of this document, the terms and definitions given in ISO 389-1 and IEC 60318-1 apply.

---

1) Under revision.

2) To be withdrawn; its contents will be included in a revised IEC 60318-1.

3) To become IEC 60318-4.

## 4 Specifications

The reference equivalent threshold sound pressure levels, RETSPLs, depend on the model of earphone and on the combination of the ear simulator and adapter used to calibrate it. Specified values for two different earphones [an insert earphone (ETYMOTIC RESEARCH ER-2 together with eartips type ER1-14A) and a closed-type circumaural earphone (SENNHEISER HDA 200)] are given in Table 1.

**Table 1 — Reference equivalent threshold sound pressure levels**

Frequency Hz	RETSPL re. 20 µPa <sup>a</sup>	
	dB	
	Etymotic Research ER-2 <sup>b,c</sup> Ear simulator: IEC 60711 <sup>e</sup> Adapter: ISO 389-2:1994, Figure 2b)	SENNHEISER HDA 200 <sup>b,d</sup> Ear simulator: IEC 60318-1 <sup>c</sup> Adapter: IEC 60318-2:1998, Figure 1
8 000	19	17,5
9 000	16	19
10 000	20	22
11 200	30,5	23
12 500	37	27,5
14 000	43,5	35
16 000	53	56

NOTE RETSPL values for the KOSS HV/1A earphone, which is no longer in production, are given in Annex B for information.

<sup>a</sup> Each of the values is the arithmetic mean of the median values derived from several laboratories rounded to the nearest half decibel.

<sup>b</sup> Model of earphone with ear simulator and adapter used.

<sup>c</sup> Values for the Etymotic Research earphone are based on the results of two laboratories (see Annex A). They are derived from determinations of the threshold of hearing of otologically normal persons under conditions as close as possible to those described in Reference [3].

The characteristics of SENNHEISER HDA 200 earphone in the extended high-frequency range depend on temperature, especially at 12,5 kHz; see Reference [5]. It is therefore recommended to calibrate audiometers equipped with these earphones as closely as possible within the temperature range 21 °C to 25 °C.

<sup>d</sup> Values for the SENNHEISER earphone are based on the results of four laboratories. Temperature-dependence information is not available.

<sup>e</sup> IEC 60711 is at present defined in the frequency range up to and including 10 kHz but is according to this document used up to 16 kHz. A revision with a frequency range up to 16 kHz is planned and will become IEC 60318-4.

The headband force of the circumaural earphone SENNHEISER HDA 200 shall be within 10,0 ± 1,0 N. The headband force shall be measured when the two earphones are separated by 145 mm and the height of the earphone is adjusted to provide a distance of 130 mm measured between the centre (top) of the headband and a line between the centres of the earphones.

The eartip of the insert earphone ETYMOTIC RESEARCH ER-2 shall be inserted deeply into the ear canal of a test subject so that the outer end of the ear tip is flush with the bottom of the concha.

## Annex A (informative)

### Notes on the derivation of the reference equivalent threshold sound pressure levels for audiometric earphones in the frequency range from 8 kHz to 16 kHz

The reference equivalent threshold sound pressure levels for audiometric earphones in the frequency range from 8 kHz to 16 kHz specified in this part of ISO 389 are obtained from the results of five independent experimental investigations given in References [4] to [8]. Brief particulars of the tests are given in Table A.1.

**Table A.1 — Investigations of equivalent threshold sound pressure levels for audiometric earphones in the frequency range from 8 kHz to 16 kHz**

Parameter	Investigation				
	Reference [4]	Reference [5]	Reference [6]	Reference [7]	Reference [8]
Types of test earphone(s)	SENNHEISER HDA 200	SENNHEISER HDA 200	SENNHEISER HDA 200 Etymotic Research ER-2	SENNHEISER HDA 200	Etymotic Research ER-2
Number of test subjects	24	28	31	38	24
Number of ears tested	24	28	62 (HDA 200), 31(ER-2)	38	24
Males/ females	15/9	18/10	17/14	15/23	13/11
Age range of test subjects, years	18 to 23	18 to 24	18 to 25	18 to 25	18 to 25
Frequencies tested, kHz	8 to 9 10 to 11,2 12,5 to 14 16	8 to 9 10 to 11,2 12,5 to 14 16	8 to 9 10 to 11,2 12,5 to 14 16	8 to 9 10 to 11,2 12,5 to 14 16	8 to 9 10 to 11,2 12,5 to 14 16
Type of ear simulator used	IEC 60318-1	IEC 60318-1	IEC 60318-1 for HDA 200 IEC 60711 for ER-2	IEC 60318-1	IEC 60711
Type of adapter used for test earphone	IEC 60318-2:1998, Figure 1	IEC 60318-2:1998, Figure 1	IEC 60318-2:1998, Figure 1, for HDA 200 and ISO 389-2:1994, Figure 2b), for ER-2	IEC 60318-2:1998, Figure 1	ISO 389-2:1994, Figure 2b)
Statistical quantity used	median	median	median	median	median

**Annex B**  
(informative)

**RETSPL values for Koss HV/1A**

RETSPL values for the KOSS HV/1A earphone were specified in the earlier version of this International Standard. Though this earphone is no longer in production, some users can, for a period, still need the RETSPL values. They are, therefore, given in this annex for information together with the specifications and the description of positioning of an adapter making the IEC 60318-1 ear simulator complying with the KOSS earphone specifications.

**Table B.1 — Recommended reference equivalent threshold sound pressure levels**

Frequency Hz	RETSPL re. 20 µPa dB
8 000	15,5
9 000	19,5
10 000	24
11 200	23
12 500	25
14 000	34,5
16 000	52

Dimensions in millimetres unless otherwise indicated

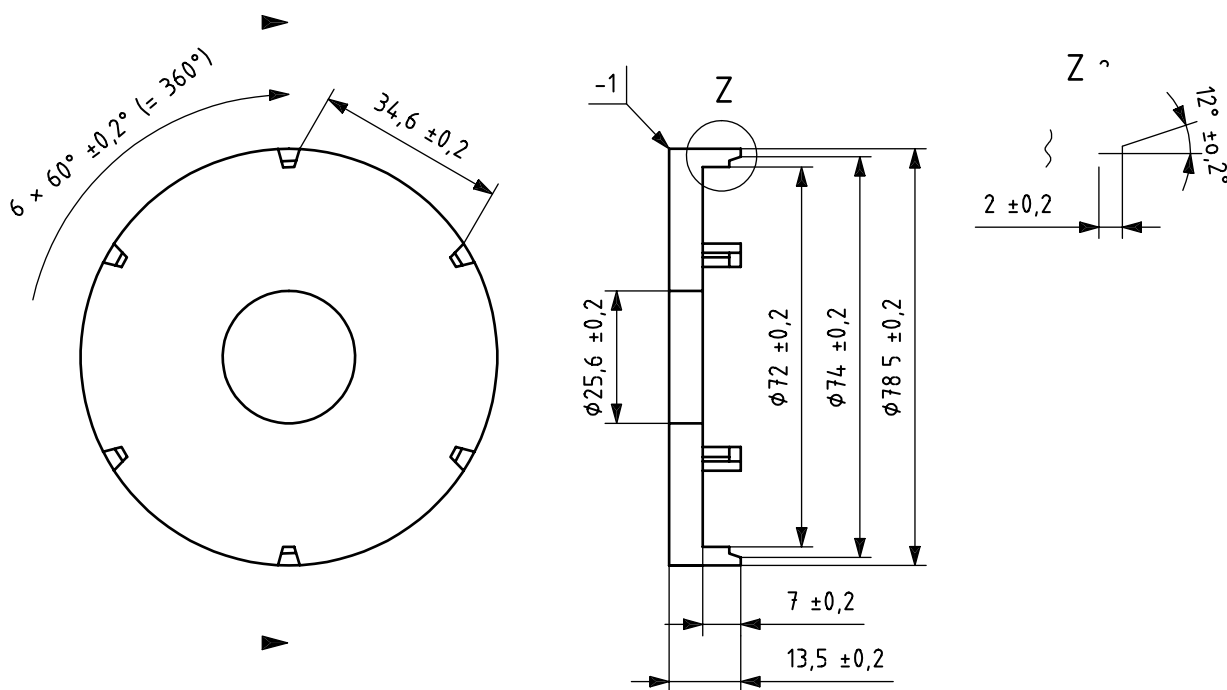

**Figure B.1 — Adapter for use with IEC 60318-1 ear simulator**

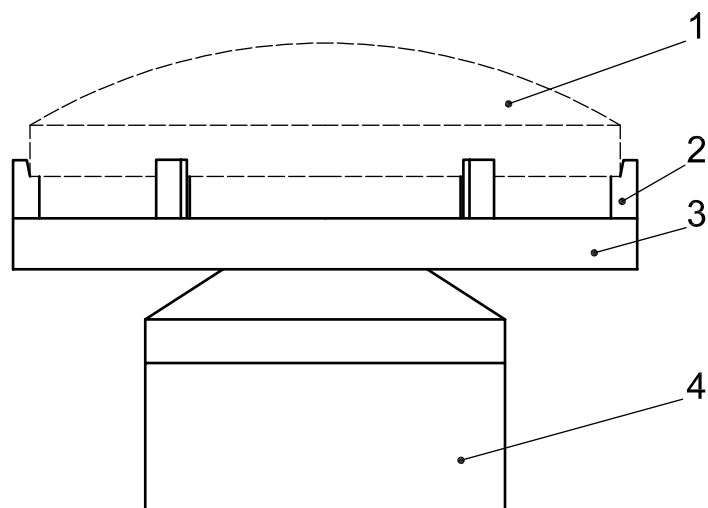

**Key**

- 1 example of a KOSS HV/1A earphone
- 2 distance clamp
- 3 adapter
- 4 IEC 60318-1 ear simulator

**Figure B.2 — Position of the adapter on the IEC 60318-1 ear simulator**

## Bibliography

- [1] ISO 389-8, *Acoustics — Reference zero for the calibration of audiometric equipment — Part 8: Reference equivalent threshold sound pressure levels for pure tones and circumaural earphones*
- [2] IEC 60645-4, *Audiometers — Part 4: Equipment for extended high-frequency audiometry*
- [3] ISO/TC 43/WG 1, Preferred test conditions for determining hearing thresholds for standardization. *Scand. Audiol.*, **25**, 1996, pp. 45-52<sup>4)</sup>
- [4] TAKESHIMA, H., HIRAOKA, T., KUMAGAI, M., SONE, T. and SUZUKI, Y., Reference equivalent threshold sound pressure levels for new earphones. In: *Proceedings of 15th International Congress on Acoustics*, Trondheim, Norway, 1995, pp. 297-300
- [5] GÖSSING, P. and RICHTER, U., Characteristic data of the circumaural earphone Sennheiser HD 200 in the conventional and the extended high frequency range. In: Richter, U. (ed.). *Characteristic data of different kinds of earphones used in the extended high frequency range for pure-tone audiometry*. PTB report PTB-MA-72. Braunschweig 2003
- [6] HAN, L.A. and POULSEN, T., Equivalent Threshold Sound Pressure Levels for Sennheiser HDA 200 Earphone and the Etymotic Research ER-2 Insert Earphone in the Frequency Range 125 Hz to 16 kHz. *Scand Audiol.*, **27**, 1998, pp. 105-112
- [7] SCHÖNFELD, U., REUTER, W., FISCHER, R. and GROSS, M., Hearing thresholds of otologically normal subjects in the extended high-frequency range using the earphone HDA 200. In: Richter, U. (ed.). *Characteristic data of different kinds of earphones used in the extended high frequency range for pure-tone audiometry*. PTB report PTB-MA-72. Braunschweig 2003
- [8] RICHTER, U., Equivalent threshold sound pressure levels of the insert earphones Etymotic Research ER-2A and ER-4A in the extended high-frequency range. In: Richter, U. (ed.). *Characteristic data of different kinds of earphones used in the extended high frequency range for pure-tone audiometry*. PTB report PTB-MA-72. Braunschweig 2003

---

4) Under preparation as ISO 389-9.





---

---

## BSI — British Standards Institution

BSI is the independent national body responsible for preparing British Standards. It presents the UK view on standards in Europe and at the international level. It is incorporated by Royal Charter.

### Revisions

British Standards are updated by amendment or revision. Users of British Standards should make sure that they possess the latest amendments or editions.

It is the constant aim of BSI to improve the quality of our products and services. We would be grateful if anyone finding an inaccuracy or ambiguity while using this British Standard would inform the Secretary of the technical committee responsible, the identity of which can be found on the inside front cover. Tel: +44 (0)20 8996 9000. Fax: +44 (0)20 8996 7400.

BSI offers members an individual updating service called PLUS which ensures that subscribers automatically receive the latest editions of standards.

### Buying standards

Orders for all BSI, international and foreign standards publications should be addressed to Customer Services. Tel: +44 (0)20 8996 9001. Fax: +44 (0)20 8996 7001. Email: [orders@bsi-global.com](mailto:orders@bsi-global.com). Standards are also available from the BSI website at <http://www.bsi-global.com>.

In response to orders for international standards, it is BSI policy to supply the BSI implementation of those that have been published as British Standards, unless otherwise requested.

### Information on standards

BSI provides a wide range of information on national, European and international standards through its Library and its Technical Help to Exporters Service. Various BSI electronic information services are also available which give details on all its products and services. Contact the Information Centre. Tel: +44 (0)20 8996 7111. Fax: +44 (0)20 8996 7048. Email: [info@bsi-global.com](mailto:info@bsi-global.com).

Subscribing members of BSI are kept up to date with standards developments and receive substantial discounts on the purchase price of standards. For details of these and other benefits contact Membership Administration. Tel: +44 (0)20 8996 7002. Fax: +44 (0)20 8996 7001. Email: [membership@bsi-global.com](mailto:membership@bsi-global.com).

Information regarding online access to British Standards via British Standards Online can be found at <http://www.bsi-global.com/bsonline>.

Further information about BSI is available on the BSI website at <http://www.bsi-global.com>.

### Copyright

Copyright subsists in all BSI publications. BSI also holds the copyright, in the UK, of the publications of the international standardization bodies. Except as permitted under the Copyright, Designs and Patents Act 1988 no extract may be reproduced, stored in a retrieval system or transmitted in any form or by any means – electronic, photocopying, recording or otherwise – without prior written permission from BSI.

This does not preclude the free use, in the course of implementing the standard, of necessary details such as symbols, and size, type or grade designations. If these details are to be used for any other purpose than implementation then the prior written permission of BSI must be obtained.

Details and advice can be obtained from the Copyright & Licensing Manager. Tel: +44 (0)20 8996 7070. Fax: +44 (0)20 8996 7553. Email: [copyright@bsi-global.com](mailto:copyright@bsi-global.com).