

Rivets, solid, in nickel alloy — Procurement specification

ICS 49.030.60

National foreword

This British Standard reproduces verbatim ISO 12288:2000 and implements it as the UK national standard.

The UK participation in its preparation was entrusted by Technical Committee ACE/12, Aerospace fasteners and fastening systems, to Subcommittee ACE/12/1, Aerospace fasteners and fastening systems (international), which has the responsibility to:

- aid enquirers to understand the text;
- present to the responsible international/European committee any enquiries on the interpretation, or proposals for change, and keep the UK interests informed;
- monitor related international and European developments and promulgate them in the UK.

A list of organizations represented on this subcommittee can be obtained on request to its secretary.

Cross-references

The British Standards which implement international or European publications referred to in this document may be found in the BSI Standards Catalogue under the section entitled “International Standards Correspondence Index”, or by using the “Find” facility of the BSI Standards Electronic Catalogue.

A British Standard does not purport to include all the necessary provisions of a contract. Users of British Standards are responsible for their correct application.

Compliance with a British Standard does not of itself confer immunity from legal obligations.

Summary of pages

This document comprises a front cover, an inside front cover, the ISO title page, pages ii to iv, pages 1 to 11 and a back cover.

The BSI copyright notice displayed in this document indicates when the document was last issued.

This British Standard, having been prepared under the direction of the Engineering Sector Committee, was published under the authority of the Standards Committee and comes into effect on 15 April 2000

Amendments issued since publication

Amd. No.	Date	Comments

INTERNATIONAL
STANDARD

BS A 351:2000
ISO
12288

First edition
2000-03-01

**Aerospace — Rivets, solid, in nickel
alloy — Procurement specification**

*Aéronautique et espace — Rivets ordinaires, en alliage de nickel —
Spécification d'approvisionnement*



Reference number
ISO 12288:2000(E)

Contents

Page

Foreword.....	iv
1 Scope	1
2 Normative references	1
3 Terms and definitions	1
4 Quality assurance	3
4.1 General.....	3
4.1.1 Approval of manufacturers.....	3
4.1.2 Acceptance of solid rivets	3
4.2 Acceptance inspection and test conditions	3
4.3 Use of "Statistical process control (SPC)"	4
5 Requirements and test methods.....	4
6 Records and test reports	10
7 Certificate of compliance	11

Foreword

ISO (the International Organization for Standardization) is a worldwide federation of national standards bodies (ISO member bodies). The work of preparing International Standards is normally carried out through ISO technical committees. Each member body interested in a subject for which a technical committee has been established has the right to be represented on that committee. International organizations, governmental and non-governmental, in liaison with ISO, also take part in the work. ISO collaborates closely with the International Electrotechnical Commission (IEC) on all matters of electrotechnical standardization.

International Standards are drafted in accordance with the rules given in the ISO/IEC Directives, Part 3.

Draft International Standards adopted by the technical committees are circulated to the member bodies for voting. Publication as an International Standard requires approval by at least 75 % of the member bodies casting a vote.

Attention is drawn to the possibility that some of the elements of this International Standard may be the subject of patent rights. ISO shall not be held responsible for identifying any or all such patent rights.

International Standard ISO 12288 was prepared by Technical Committee ISO/TC 20, *Aircraft and space vehicles*, Subcommittee SC 4, *Aerospace fastener systems*.

Aerospace — Rivets, solid, in nickel alloy — Procurement specification

1 Scope

This International Standard specifies the characteristics and quality assurance requirements for solid rivets made in nickel alloy for aerospace construction.

It is applicable whenever it is referenced in a definition document.

2 Normative references

The following normative documents contain provisions which, through reference in this text, constitute provisions of this International Standard. For dated references, subsequent amendments to, or revisions of, any of these publications do not apply. However, parties to agreements based on this International Standard are encouraged to investigate the possibility of applying the most recent editions of the normative documents indicated below. For undated references, the latest edition of the normative document referred to applies. Members of ISO and IEC maintain registers of currently valid International Standards.

ISO 2859-1:1999, *Sampling procedures for inspection by attributes — Part 1: Sampling schemes indexed by acceptance quality limit (AQL) for lot-by-lot inspection.*

ISO 7870:1993, *Control charts — General guide and introduction.*

ISO 7966:1993, *Acceptance control charts.*

ISO 8258:1991, *Shewhart control charts.*

ISO 9002:1994, *Quality systems — Model for quality assurance in production, installation and servicing.*

ISO 17057:1999, *Aerospace — Rivets, solid — Test method.*

ISO/TR 13425:1995, *Guide for the selection of statistical methods in standardization and specification.*

ASTM E112:1996¹⁾, *Standard Test Methods for Determining Average Grain Size.*

3 Terms and definitions

For the purposes of this International Standard, the following terms and definitions apply.

1) Published by: American Society for Testing and Materials (ASTM), 1916, Race street, Philadelphia, PA 19103, USA.

3.1

batch

quantity of finished rivets, using the same process, from a single material cast (single heat of alloy), having the same number of definition document, diameter and length code, heat treated together to the same specified condition and produced as one continuous run

3.2

rivet wire sample

length of wire, sampled at one end of the coil used for the manufacture of rivets of the batch

NOTE The rivet wire samples should undergo the same heat treatments as the rivets of the batch, at the same time.

3.3

rivet sample

rivet sampled at random from the batch

3.4

definition document

document specifying directly or indirectly all the requirements for rivets

NOTE The definition document may be an International Standard, an in-house standard or a drawing.

3.5

crack

rupture in the material which may extend in any direction and which may be intercrystalline or transcrystalline in character

3.6

seam

longitudinal open surface defect

3.7

lap

surface defect caused by folding over metal fins or sharp corners and then forming them into the surface

3.8

cold shut

doubling over of metal which may occur during the cold heading operation

3.9

blistering

defect in the metal on or near the surface, resulting from expansion of gas in a sub-surface zone

3.10

pit

small sharp cavity in a metal surface caused by non-uniform electrodeposition or by corrosion

3.11

critical defect

defect that, according to judgement and experience, is likely to result in hazardous or unsafe conditions for individuals using, maintaining, or depending upon the considered product, or that is likely to prevent performance of the function of a major end item

3.12

major defect

defect, other than critical, that is likely to result in a failure or to reduce materially the usability of the considered product for its intended purpose

3.13**minor defect**

defect that is not likely to reduce materially the usability of the considered product for its intended purpose, or that represents a departure from established specification having little bearing on the effective use or operation of this product

3.14**sampling plan**

plan according to which one or more samples are taken in order to obtain information and to reach a decision, if possible

3.15**acceptance quality limit****AQL**

maximum percent defective (or the maximum number of defects per hundred units) that, for purposes of sampling inspection, can be considered satisfactory as a process average

NOTE Variant: quality limit which in a sampling plan corresponds to a specified but relatively high probability of acceptance.

4 Quality assurance**4.1 General****4.1.1 Approval of manufacturers**

The manufacturer shall conform to the quality assurance and approval procedures defined in ISO 9002. The purpose of these procedures is to ensure that a manufacturer has a quality system and is capable of continuous production of solid rivets complying with the specified quality requirements.

The approval of the manufacturer shall be granted by the Certification Authorities, or their appointed representative, who may be the prime contractor.

4.1.2 Acceptance of solid rivets

The purpose of acceptance inspection and tests of a solid rivet is to check, as simply as possible, using a method which is inexpensive but the most representative of the actual conditions of use, with the uncertainty inherent in statistical sampling, that the solid rivets satisfy the requirements of this International Standard.

Acceptance inspections and tests shall be carried out by the manufacturer, or under his responsibility.

The manufacturer is responsible for the quality of the solid rivets manufactured.

4.2 Acceptance inspection and test conditions

Acceptance inspections and tests (requirements, methods, numbers of solid rivets) are specified in Table 1. They shall be carried out on each batch. Solid rivets shall be selected from the batch to be tested by simple random sampling.

Each solid rivet may be submitted to several inspections or tests, provided that none of its characteristics to be verified has been previously altered during any of these inspections or tests.

The solid rivets to be subjected to destructive inspections or tests may be those on which non-destructive inspections or tests have been carried out.

Batches declared unacceptable after the acceptance inspection shall be resubmitted for acceptance only after all the defective units have been removed and/or defects have been corrected.

In this case, the attribute(s) which caused the rejection shall be verified using a sample of twice the normal size with the same acceptance limit.

If the reason for rejection results from the method, the test apparatus or from faulty heat treatment which can be rectified in a satisfactory manner, the tests may be repeated after elimination of the cause, provided that any surface treatment be removed prior to heat treatment, without being detrimental to rivet final use. A note to this effect shall be added to the corresponding inspection documents.

Unless otherwise specified, the test temperature shall be the ambient temperature.

4.3 Use of "Statistical process control (SPC)"

When a characteristic is obtained by a controlled statistical process, the manufacturer has the possibility, in order to declare conformity of the characteristic, of refraining from the final systematic sampling provided for in this International Standard, if he is capable of **formally justifying** this choice by using ISO/TR 13425 and the standards quoted in it as a basis.

This justification will include the following phases:

- analysis of the product's key characteristics;
- analysis of the risks for each implemented process;
- determination of the parameters and/or characteristics to be respected under SPC;
- determination of the capabilities of each process;
- drawing up an inspection plan and integration in the manufacturing process;
- drawing up of routes and control charts (ISO 7966, ISO 7870, ISO 8258);
- use of control charts for data consolidation;
- determination of the audits to be run and the control to be carried out to ensure reliability of the device.

To be usable in production, this process shall be or should be validated beforehand by the qualifying body, either during the qualification phase, or *a posteriori* according to the case, by analysing the justificatory file and the results of the qualification inspections such as provided for in clause 5.

5 Requirements and test methods

See Table 1.

Table 1 — Requirements and test methods

Clause	Characteristic	Requirement	Inspection and test method	Classification of defects and sampling
5.1	Material	In accordance with the product standard or definition document.	See material standard.	
5.2	Dimensions	In accordance with the product standard or definition document.	Usual instruments In case of dispute, the projection method at a magnification of 25 times for diameters ≤ 6 mm and 10 times for diameters > 6 mm, shall be used as the reference method. Checks shall be made at three equidistant points around the rivet.	Table 2
5.3	Manufacturing			
5.3.1	Heat treatment	As specified in the material standard.		
5.3.2	Workmanship	No cracks or blistering. Localized, non-continuous seams, laps, cold shuts, tool marks and pits having a maximum depth of 0,07 mm are permissible.	Visual examination with or without magnification. The magnification shall be limited to six times. Defect depth shall be measured perpendicular to a line tangent with the surface. In the event of any doubt, the test specified in 5.4.2 shall be used as the reference method.	Table 2
5.3.3	Surface treatment	Treatment in accordance with the product standard or definition document.	See applicable surface treatment standard.	Table 2
5.4	Mechanical properties			
5.4.1	Double shear strength	See Table 3.	ISO 17057	Table 4
5.4.2	Drivability	No cracks permitted.	Test device: see Figure 1. Test method: a) progressively upset the protruding end, until the values specified in Figure 2 are obtained; b) examine visually without magnification. Sample definition: see Figure 3. Test carried out at delivery condition.	Table 2

Table 1 (continued)

Clause	Characteristic	Requirement	Inspection and test method	Classification of defects and sampling
5.5	Metallurgical properties			
5.5.1	Grain size	Grain size shall be finer than size five in accordance with ASTM E112.	Longitudinal cutting through the shank, polishing and etching using the appropriate reagents and then macroscopic examination.	One test per batch
5.6	Product identification marking	In accordance with the product standard or definition document.	Visual examination.	Table 2
5.7	Delivery			
5.7.1	Packaging	<p>The packaging shall:</p> <ul style="list-style-type: none"> — prevent any damage or corrosion from occurring during handling, transportation and storage; — only contain rivets from the same batch, the number of which is left to the manufacturer's discretion; however, the maximum mass is 25 kg; — contain a copy of the manufacturer's delivery note relating to the batch. Furthermore, this note may be sent separately upon request. <p>Any particular or additional packaging requirements shall be specified with the order.</p>	Visual examination.	
5.7.2	Labelling	<p>Durable labels, secured to the packaging, bearing the following information:</p> <ul style="list-style-type: none"> — designation; — quantity (mass or number); — manufacturer's name; — batch number. 	Visual examination.	

Table 2 — Classification of defects

Category of defects	Acceptance quality limit (AQL)	Characteristics
Major	See Table 5.	Head diameter Head angle Head protrusion Product identification marking ^a Shank diameter Length Cracks Blistering
	See Table 6.	Drivability during installation
Minor	See Table 6.	All other dimensions, appearance items and miscellaneous defects
^a Including legibility.		

Table 3 — Double shear strength

Rivet diameter ^a <i>D</i> ₁ mm		Minimum double shear strength (N) ^b		
		Alloy designation (minimum shear stress)		
nom.	min.	Ni30Cu Monel 400 (340 MPa)	Ni19Cr0,4Ti Nimonic 75 (440 MPa)	Ni15,5Cr8Fe Inconel 600 (440 MPa)
1,6	1,52	1 234	1 597	1 597
2	1,92	1 969	2 548	2 548
2,5	2,42	3 128	4 048	4 048
3	2,92	4 554	5 893	5 893
3,5	3,395	6 156	7 966	7 966
4	3,895	8 102	10 485	10 485
5	4,895	12 797	16 561	16 561
6	5,895	18 560	24 018	24 018
8	7,87	33 079	42 808	42 808
10	9,87	52 028	67 330	67 330
^a For other diameters, use the formula given in footnote ^b .				
^b Values calculated using the following formula: $(D_1 \text{ min.})^2 \times \frac{\pi}{4} \times 2 \times (\text{min. shear stress})$				

Table 4 — Sampling plans for the inspection of double shear strength

Batch size	Sample size	Inspection level	Sampling plan ^{a,b}			AQL %
			Sampling number	Acceptance	Rejection	
≤ 500	2	S-1	First	0	2	15
			Second	1		
501 to 35 000	3		First	0		10
			Second	1		
≥ 35 001	5		First	0		6,5
			Second	1		

^a In accordance with ISO 2859-1, double sampling, normal inspection.

^b Other sampling plans of ISO 2859-1 may be used, provided that they ensure an equivalent quality limit.

Table 5 — Sampling plans for visual inspection and inspection of dimensional characteristics

Batch size	Sample size	Inspection level	Sampling plan ^{a,b}			AQL %
			Sampling number	Acceptance	Rejection	
91 to 150	5	I	First	0	3	10
			Second	3	4	
151 to 280	8		First	0	3	6,5
			Second	3	4	
281 to 500	13		First	1	4	
			Second	4	5	
501 to 1 200			First	0	3	4
			Second	3	4	
1 201 to 10 000	20		First	2	5	6,5
			Second	6	7	
10 001 to 35 000		First	1	3	4	
		Second	4	5		
35 001 to 500 000	50	First	3	6		
		Second	9	10		
≥ 500 001	80	First	3	6	2,5	
		Second	9	10		

^a In accordance with ISO 2859-1, double sampling, normal inspection.

^b Other sampling plans of ISO 2859-1 may be used, provided that they ensure an equivalent quality limit.

Table 6 — Sampling plans for the inspection of mechanical and metallurgical characteristics

Batch size	Sample size	Sampling plan ^{a,b}				AQL %
		Inspection level	Sampling number	Acceptance	Rejection	
91 to 150	5	I	First	1	3	15
			Second	4	5	
151 to 500	8	S-4	First	1	3	10
Second			4	5		
501 to 3 200		S-3	First	0	3	
			Second	3	4	
3 201 to 35 000	13	S-3	First	2	5	
Second			6	7		
35 001 to 500 000	20	S-3	First	3	6	
Second			9	10		
≥ 500 001	32	S-3	First	3	6	6,5
			Second	9	10	

^a In accordance with ISO 2859-1, double sampling, normal inspection.

^b Other sampling plans of ISO 2859-1 may be used, provided that they ensure an equivalent quality limit.

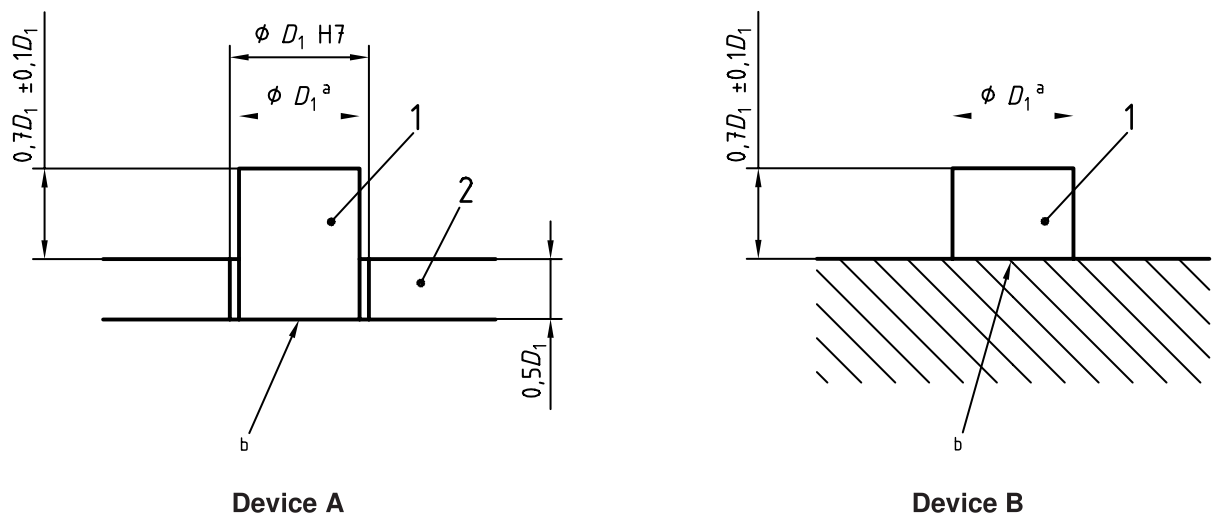

Key

- 1 Rivet sample (see Figure 3)
- 2 Steel plate

NOTE Test device A or B at discretion, device A to be used as the reference method in case of dispute.

- ^a D_1 = rivet nominal diameter.
- ^b Preformed face.

Figure 1

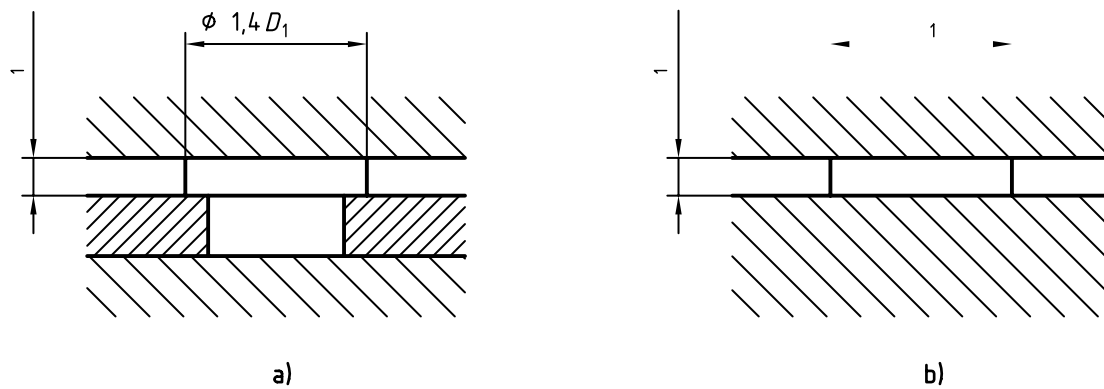

NOTE Figures 2 a) and 2 b) correspond to devices A and B in Figure 1, respectively.

Figure 2

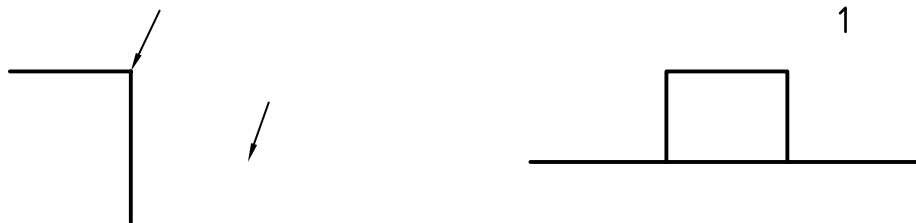

Key

1 Rivet sample

a Tail end of rivet in delivery condition.

b Cutting plane.

Figure 3

6 Records and test reports

For each batch, the manufacturer shall have on file, for at least five years, documentation which can be communicated to a user upon request. This documentation shall include at least:

- a) a copy of documents concerning the material batch and the test references;
- b) the documents concerning the heat treatment of the batch;
- c) the inspection results and tests of the batch.

7 Certificate of compliance

Each shipment shall be accompanied by a certificate of compliance stating that the product satisfies the requirements of this International Standard.

BSI — British Standards Institution

BSI is the independent national body responsible for preparing British Standards. It presents the UK view on standards in Europe and at the international level. It is incorporated by Royal Charter.

Revisions

British Standards are updated by amendment or revision. Users of British Standards should make sure that they possess the latest amendments or editions.

It is the constant aim of BSI to improve the quality of our products and services. We would be grateful if anyone finding an inaccuracy or ambiguity while using this British Standard would inform the Secretary of the technical committee responsible, the identity of which can be found on the inside front cover. Tel: 020 8996 9000. Fax: 020 8996 7400.

BSI offers members an individual updating service called PLUS which ensures that subscribers automatically receive the latest editions of standards.

Buying standards

Orders for all BSI, international and foreign standards publications should be addressed to Customer Services. Tel: 020 8996 9001. Fax: 020 8996 7001.

In response to orders for international standards, it is BSI policy to supply the BSI implementation of those that have been published as British Standards, unless otherwise requested.

Information on standards

BSI provides a wide range of information on national, European and international standards through its Library and its Technical Help to Exporters Service. Various BSI electronic information services are also available which give details on all its products and services. Contact the Information Centre. Tel: 020 8996 7111. Fax: 020 8996 7048.

Subscribing members of BSI are kept up to date with standards developments and receive substantial discounts on the purchase price of standards. For details of these and other benefits contact Membership Administration. Tel: 020 8996 7002. Fax: 020 8996 7001.

Copyright

Copyright subsists in all BSI publications. BSI also holds the copyright, in the UK, of the publications of the international standardization bodies. Except as permitted under the Copyright, Designs and Patents Act 1988 no extract may be reproduced, stored in a retrieval system or transmitted in any form or by any means – electronic, photocopying, recording or otherwise – without prior written permission from BSI.

This does not preclude the free use, in the course of implementing the standard, of necessary details such as symbols, and size, type or grade designations. If these details are to be used for any other purpose than implementation then the prior written permission of BSI must be obtained.

If permission is granted, the terms may include royalty payments or a licensing agreement. Details and advice can be obtained from the Copyright Manager. Tel: 020 8996 7070.