

**Nuts, anchor,
self-locking, fixed, 90°
corner, with
counterbore, with
MJ threads,
classifications:
1 100 MPa (at ambient
temperature)/235 °C,
1 100 MPa (at ambient
temperature)/315 °C
and 1 100 MPa
(at ambient
temperature)/425 °C —
Dimensions**

ICS 49.030.30

National foreword

This British Standard reproduces verbatim ISO 3221:1998 and implements it as the UK national standard.

The UK participation in its preparation was entrusted by Technical Committee ACE/12, Aerospace fasteners and fastening systems, to Subcommittee ACE/12/1, Aerospace fasteners and fastening systems (International), which has the responsibility to:

- aid enquirers to understand the text;
- present to the responsible international/European committee any enquiries on the interpretation, or proposals for change, and keep the UK interests informed;
- monitor related international and European developments and promulgate them in the UK.

A list of organizations represented on this subcommittee can be obtained on request to its secretary.

Cross-references

The British Standards which implement international or European publications referred to in this document may be found in the BSI Standards Catalogue under the section entitled “International Standards Correspondence Index”, or by using the “Find” facility of the BSI Standards Electronic Catalogue.

A British Standard does not purport to include all the necessary provisions of a contract. Users of British Standards are responsible for their correct application.

Compliance with a British Standard does not of itself confer immunity from legal obligations.

Summary of pages

This document comprises a front cover, an inside front cover, pages i and ii, the ISO title page, page ii, pages 1 to 3 and a back cover.

This standard has been updated (see copyright date) and may have had amendments incorporated. This will be indicated in the amendment table on the inside front cover.

Amendments issued since publication

| Amd. No. | Date | Comments |
|----------|------|----------|
| | | |
| | | |
| | | |
| | | |

This British Standard, having been prepared under the direction of the Engineering Sector Committee, was published under the authority of the Standards Committee and comes into effect on 15 February 1999

© BSI 05-1999

ISBN 0 580 32168 1

Contents

| | Page |
|--------------------------------|--------------------|
| National foreword | Inside front cover |
| Foreword | ii |
| Introduction | 1 |
| 1 Scope | 1 |
| 2 Normative references | 1 |
| 3 Configuration and dimensions | 1 |
| Figure 1 | 2 |
| Table 1 | 3 |

INTERNATIONAL
STANDARD

ISO
3221

Second edition
1998-11-15

**Aerospace — Nuts, anchor, self-locking,
fixed, 90° corner, with counterbore, with
MJ threads, classifications: 1 100 MPa (at
ambient temperature)/235 °C, 1 100 MPa (at
ambient temperature)/315 °C and 1 100 MPa
(at ambient temperature)/425 °C —
Dimensions**

*Aéronautique et espace — Écrous à river, à freinage interne, fixes,
d'angle 90°, avec chambrage, à filetage MJ, classifications: 1 100 MPa (à
température ambiante)/235 °C, 1 100 MPa (à température
ambiante)/315 °C et 1 100 MPa (à température ambiante)/425 °C —
Dimensions*



Foreword

ISO (the International Organization for Standardization) is a worldwide federation of national standards bodies (ISO member bodies). The work of preparing International Standards is normally carried out through ISO technical committees. Each member body interested in a subject for which a technical committee has been established has the right to be represented on that committee. International organizations, governmental and non-governmental, in liaison with ISO, also take part in the work. ISO collaborates closely with the International Electrotechnical Commission (IEC) on all matters of electrotechnical standardization.

International Standards are drafted in accordance with the rules given in the ISO/IEC Directives, Part 3.

Draft International Standards adopted by the technical committees are circulated to the member bodies for voting. Publication as an International Standard requires approval by at least 75 % of the member bodies casting a vote.

International Standard ISO 3221 was prepared by Technical Committee ISO/TC 20, *Aircraft and space vehicles*, Subcommittee SC 4, *Aerospace fastener systems*.

This second edition cancels and replaces the first edition (ISO 3221:1989), which has been technically revised.

Descriptors: Aircraft industry, fasteners, MJ threads, nuts (fasteners), anchor nuts, self-locking nuts, counterbore nuts, classification, form specifications, dimensions.

Introduction

The dimensions specified in this International Standard have been determined to allow production of a part which will satisfy the requirements of the procurement specification ISO 5858.

1 Scope

This International Standard specifies the dimensions of self-locking, fixed, 90° corner anchor nuts, with counterbore, with MJ threads, of classifications: 1 100 MPa ¹⁾/235 °C ²⁾, 1 100 MPa ¹⁾/315 °C ²⁾ and 1 100 MPa ¹⁾/425 °C ²⁾.

This International Standard is only applicable for the compilation of aerospace product standards.

2 Normative references

The following normative documents contain provisions which, through reference in this text, constitute provisions of this International Standard. For dated references, subsequent amendments to, or revisions of, any of these publications do not apply. However, parties to agreements based on this International Standard are encouraged to investigate the possibility of applying the most recent editions of the normative documents indicated below. For undated references, the latest edition of the normative document referred to applies. Members of ISO and IEC maintain registers of currently valid International Standards.

ISO 5855-2:1988, *Aerospace — MJ threads — Part 2: Limit dimensions for bolts and nuts.*

ISO 5858:1991, *Aerospace — Self-locking nuts with maximum operating temperature less than or equal to 425 °C — Procurement specification.*

ISO 8788:1987, *Aerospace — Fasteners — Tolerances of form and position for nuts.*

3 Configuration and dimensions

See Figure 1 and Table 1. Dimensions and tolerances are expressed in millimetres. They apply after any surface coating(s) but before the application of any lubricant.

The metallic cap (optional) shall remain joined to the nut at the maximum operating temperature (type of attachment at the user's discretion).

See ISO 5858 for the test conditions.

¹⁾ Corresponds to the minimum tensile stress which the nut is able to withstand at ambient temperature without breaking or cracking when tested with a bolt of a higher strength class.

²⁾ Maximum temperature that the nut is able to withstand, without permanent alteration to its original characteristics, after ambient temperature has been restored. The maximum temperature is conditioned by the surface treatment.

$6.3 / (3.2)^a$

Remove sharp edges 0,1 to 0,4

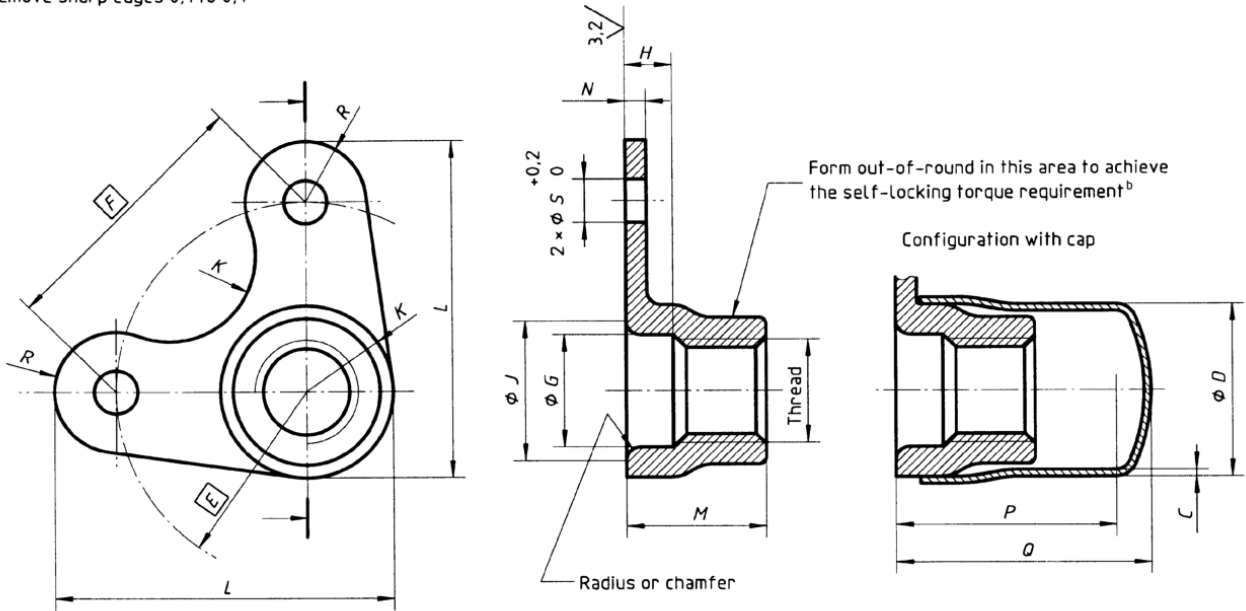

Alternatives: countersunk rivet holes (when specified by purchaser) may be dimpled or cut countersunk (at manufacturer's option)

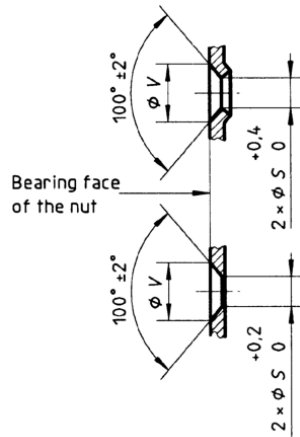

Tolerances of form and position shall conform to those specified in ISO 8788. Details of form not stated are at the manufacturer's discretion.

^aThese values, in micrometres, apply before any surface coating(s) is (are) applied. The values do not apply to threads, punched holes or shear edges the surface texture of which will be as achieved by the usual manufacturing methods.

^bTooling marks permissible in this area

Figure 1

Table 1

| Diameter code | Thread ^a | <i>C</i> | <i>D</i> | <i>E</i> | <i>F</i> | <i>G</i> | <i>H</i> | <i>j</i> ^b | <i>K</i> | <i>L</i> | <i>M</i> | <i>N</i> | <i>p</i> ^c | <i>Q</i> | <i>R</i> | <i>S</i> | <i>V</i> |
|---------------|---------------------|----------|----------|----------|----------|----------|----------|-----------------------|----------|----------|----------|----------|-----------------------|----------|----------|----------|----------|
| | | max. | max. | | | min. | min. | max. | max. | max. | max. | max. | max. | max. | max. | ≈ | |
| 030 | MJ3 × 0,5-4H6H | — | — | 6 | 8,5 | — | — | 4,6 | 3 | 11,7 | 3,2 | 1 | — | — | 2,5 | 2,5 | 4,8 |
| 040 | MJ4 × 0,7-4H6H | 0,4 | 6,6 | 8,5 | 12 | 4,4 | 2,2 | 6,2 | 4 | 15,7 | 5,8 | | 11 | 13 | 3 | | |
| 050 | MJ5 × 0,8-4H6H | | 8,1 | 9,5 | 13,4 | 5,5 | 2,4 | 7,3 | 4,5 | 17,2 | 6,9 | | 11,4 | 13,4 | | | |
| 060 | MJ6 × 1-4H5H | 0,5 | 9,2 | 11 | 15,6 | 6,5 | 2,7 | 8,7 | 5 | 19,7 | 8,1 | 1,2 | 12,7 | 14,7 | 3,5 | 3 | 5,7 |
| 080 | MJ8 × 1-4H5H | | 12,8 | | | 8,5 | | 10,9 | 6,5 | 21,2 | 9,9 | 1,5 | 15 | 18 | | | |
| 100 | MJ10 × 1,25-4H5H | | 15 | 13 | 18,4 | 10,5 | 3 | 12,9 | 8,1 | 25,8 | 12 | 1,6 | 20,2 | 22 | 4,5 | 3,5 | 6,6 |

^a In accordance with ISO 5855-2. In the self-locking zone, the tolerances apply before forming out-of-round.
^b Measured at sharp corners (chamfered) or point of tangency (radiused)
^c Maximum protrusion of the bolt

BSI — British Standards Institution

BSI is the independent national body responsible for preparing British Standards. It presents the UK view on standards in Europe and at the international level. It is incorporated by Royal Charter.

Revisions

British Standards are updated by amendment or revision. Users of British Standards should make sure that they possess the latest amendments or editions.

It is the constant aim of BSI to improve the quality of our products and services. We would be grateful if anyone finding an inaccuracy or ambiguity while using this British Standard would inform the Secretary of the technical committee responsible, the identity of which can be found on the inside front cover.
Tel: 020 8996 9000. Fax: 020 8996 7400.

BSI offers members an individual updating service called PLUS which ensures that subscribers automatically receive the latest editions of standards.

Buying standards

Orders for all BSI, international and foreign standards publications should be addressed to Customer Services. Tel: 020 8996 9001. Fax: 020 8996 7001.

In response to orders for international standards, it is BSI policy to supply the BSI implementation of those that have been published as British Standards, unless otherwise requested.

Information on standards

BSI provides a wide range of information on national, European and international standards through its Library and its Technical Help to Exporters Service. Various BSI electronic information services are also available which give details on all its products and services. Contact the Information Centre.
Tel: 020 8996 7111. Fax: 020 8996 7048.

Subscribing members of BSI are kept up to date with standards developments and receive substantial discounts on the purchase price of standards. For details of these and other benefits contact Membership Administration.
Tel: 020 8996 7002. Fax: 020 8996 7001.

Copyright

Copyright subsists in all BSI publications. BSI also holds the copyright, in the UK, of the publications of the international standardization bodies. Except as permitted under the Copyright, Designs and Patents Act 1988 no extract may be reproduced, stored in a retrieval system or transmitted in any form or by any means – electronic, photocopying, recording or otherwise – without prior written permission from BSI.

This does not preclude the free use, in the course of implementing the standard, of necessary details such as symbols, and size, type or grade designations. If these details are to be used for any other purpose than implementation then the prior written permission of BSI must be obtained.

If permission is granted, the terms may include royalty payments or a licensing agreement. Details and advice can be obtained from the Copyright Manager.
Tel: 020 8996 7070.