

# Manual on Flash Point Standards and Their Use

Methods and Regulations

HARRY A. WRAY, Editor



# **Manual on Flash Point Standards and Their Use: Methods and Regulations**

---

**Harry A. Wray, Editor**

ASTM Manual Series: MNL 9  
ASTM Publication Code Number (PCN)  
28-009092-31



1916 Race Street ■ Philadelphia, PA 19103

## Library of Congress Cataloging in Publication Data

Manual on flash point standards and their use : methods and regulations / Harry A. Wray, editor. -- 1st ed.

(ASTM manual series : MNL 9)

"ASTM publication code number (PCN) 28-009092-31."

Includes bibliographical references and index.

ISBN 0-8031-1410-0

1. Inflammable liquids--Flammability--Standards. I. Wray, Harry

A., 1909- . II. American Society for Testing and Materials.

III. Series: Manual (American Society for Testing and Materials) ;

9.

TP363.M246 1992

628.9'222'021873--dc20

91-45892

CIP

Copyright © 1992 AMERICAN SOCIETY FOR TESTING AND MATERIALS, Philadelphia, PA. All rights reserved. This material may not be reproduced or copied, in whole or in part, in any printed, mechanical, electronic, film, or other distribution and storage media, without the written consent of the publisher.

### Photocopy Rights

Authorization to photocopy items for internal or personal use, or the internal or personal use of specific clients, is granted by the AMERICAN SOCIETY FOR TESTING AND MATERIALS for users registered with the Copyright Clearance Center (CCC) Transactional Reporting Service, provided that the base fee of \$2.50 per copy, plus \$0.50 per page is paid directly to CCC, 27 Congress St., Salem, MA 01970; (508) 744-3350. For those organizations that have been granted a photocopy license by CCC, a separate system of payment has been arranged. The fee code for users of the Transactional Reporting Service is 0-8031-1410-4 92 \$2.50 + .50.

NOTE: This manual does not purport to address (all of) the safety problems associated with its use. It is the responsibility of the user of this manual to establish appropriate safety and health practices and determine the applicability of regulatory limitations prior to use.

Printed in Baltimore, MD

Sept. 1992

# Foreword

The ASTM Manual on Flash Point Standards and Their Use: Methods and Regulations (MNL 9) is sponsored by the ASTM Coordinating Committee for Flash Point. Harry A. Wray, Chairman Emeritus of the Committee, is editor of the publication.

# Acknowledgments

The editor acknowledges the help provided by the ASTM staff, especially Brent Backus, Dorothy Savini, and the editorial and word processing departments. The U.S. National Institute of Standards and Technology, National Center for Standards and Certification Information helped in providing lists of flash point standards of U.S. and other national standards organizations. Information obtained from U.S. standards, code, and tariff organizations, such as the National Fire Protection Association, the Underwriters Laboratories, United Parcel Service, and the Hazardous Materials Systems of the Association of American Railroads is appreciated.

The information obtained from the U.S. Regulatory Agencies and from international regulatory bodies regarding the control of flammable liquids was helpful in making this guide a source of information on international regulations.

Finally, the editor wishes to thank the members, past and present, of the ASTM Coordinating Committee for Flash Point and Related Properties, especially the present chairman and vice chairman, Mr. E. M. (Bud) Nesvig and Mr. John E. Rogerson for making available a forum for obtaining the information that provided the background for this manual.

*Harry A. Wray*  
Editor

# Contents

## PART I: ASTM FLASH POINT STANDARDS

<b>Chapter 1: Flash Point History</b>	3
1. History of Flash Point Testing	3
2. History of ASTM Flash Point Standards	3
3. Flash Point Basics	4
<b>Chapter 2: ASTM Basic Flash Point Standards</b>	5
1. Reprints of the Eight Basic ASTM Flash Point Standards Methods	6
D 56: Test Method for Flash Point by Tag Closed Tester	6
D 92: Test Method for Flash and Fire Points by Cleveland Open Cup	12
D 93: Test Methods for Flash Point by Pensky-Martens Closed Tester	17
D 1310: Test Method for Flash Point and Fire Point of Liquids by Tag Open-Cup Apparatus	30
D 3278: Test Methods for Flash Point of Liquids by Setaflash Closed-Cup Apparatus	37
D 3828: Test Methods for Flash Point by Setaflash Closed Tester	44
D 3934: Test Method for Flash/No Flash Test—Equilibrium Method by a Closed-Cup Apparatus	50
D 3941: Test Method for Flash Point by the Equilibrium Method With a Closed-Cup Apparatus	53
<b>Chapter 3: ASTM Flash Point Standards for Specific Products (Excerpts)</b>	56
1. D 115: Methods of Testing Varnishes Used for Electrical Insulation	56
2. D 117: Guide to Test Methods and Specifications for Electrical Insulating Oils of Petroleum Origin	57
3. D 154: Methods of Testing Varnishes	57
4. D 176: Methods of Solid Filling and Treating Compounds Used for Electrical Insulation	57
5. D 268: Methods of Sampling and Testing Volatile Solvents and Chemical Intermediates for Use in Paint and Related Coatings and Materials	57
6. D 333: Method for Clear and Pigmented Laquers	58
7. D 555: Guide for Testing Drying Oils	58
8. D 801: Methods of Sampling and Testing Dipentene	58
9. D 803: Methods of Testing Tall Oil	58
10. D 901: Methods of Testing Askarels	58
11. D 1131: Methods of Testing Rosin Oils	59
12. D 1168: Methods of Testing Hydrocarbon Waxes for Electrical Insulation	59

13. D 1569: Methods of Testing Detergent Alkylate	59
14. D 2071: Methods for Fatty Nitrogen Products	59
15. D 2225: Methods of Testing Silicone Fluids Used for Electrical Insulation	59
16. D 2554: Test for Flash Point of Dry Cleaning Detergents in Drycleaning Bath	59
17. D 2689: Recommended Practices for Testing Alkyd Resins	60
18. D 2833: Index of Methods for Testing Architectural Paints and Coatings	60
19. D 2939: Method of Testing Emulsified Bitumens Used as Protective Coatings	60
20. D 3065: Test Methods for Flammability of Aerosol Products	60
21. D 3105: Index of Methods for Testing Elastomeric and Plastomeric Roofing and Waterproofing Materials	60
22. D 3143: Test Method for Flash Point of Cutback Asphalt with Tag-Open Cup Apparatus	61
23. D 3288: Test Methods of Testing Magnet-Wire Enamels	62
24. D 3323: Guide for Testing Interior Solvent-Reducible Flat Wall Paints	62
25. D 3425: Guide for Testing Solvent-Reducible Interior Semigloss Wall and Trim Enamels	62
26. D 3436: Standard Practice for Sampling and Handling Aniline	62
27. D 3437: Standard Practice for Sampling and Handling Liquid Cyclic Products	62
28. D 3666: Practice for Evaluation of Inspection and Testing Agencies for Bituminous Paving Materials	63
29. D 3745: Practice for Installation of Prefabricated Asphalt Reservoir, Pond, Canal, and Ditch Liner (Exposed Type)	63
30. D 3757: Guide for Preparing Specifications for Solvent Floor Polishes	63
31. D 3809: Methods of Testing Synthetic Dielectric Fluids for Capacitors	63
32. D 4277: Guide for Testing Amino Resins	63
33. D 4712: Guide for Testing Industrial Water-Reducible Coatings	63
34. D 4733: Test Methods for Solventless Electrical Insulating Varnishes	63
35. E 502: Test Method for Selection and Use of ASTM Standards for the Determination of Flash Point of Chemicals by Closed Cup Methods	64
36. E 752: Safety and Health Requirements Relating to Occupational Exposure to Carbon Disulfide	64
<b>Chapter 4: ASTM Specifications with Flash Point Requirements (Excerpts)</b>	66
1. D 12: Raw Tung Oil	66
2. D 234: Raw Linseed Oil	66
3. D 235: Mineral Spirits (Petroleum Spirits) (Hydrocarbon Dry Cleaning Solvent)	67
4. D 312: Asphalt Used in Roofing	67
5. D 396: Fuel Oils	67
6. D 449: Asphalt Used for Damproofing and Waterproofing	68

7. D 450: Coal-Tar Pitch Used in Roofing, Damproofing, and Waterproofing	68
8. D 946: Penetration-Graded Asphalt Cement for Use in Pavement Construction	68
9. D 1227: Emulsified Asphalt Used as a Protective Coating	69
10. D 1655: Aviation Turbine Fuels	69
11. D 1786: Toluene Diisocyanate	69
12. D 1859: Petroleum for Blending with Creosotet	70
13. D 2026: Cutback Asphalt (Slow-Curing Type)	70
14. D 2027: Cutback Asphalt (Medium-Curing Type)	70
15. D 2028: Cutback Asphalt (Rapid-Curing Type)	70
16. D 2233: Chlorinated Aromatic Hydrocarbons (Askarels) for Capacitors	70
17. D 2283: Chlorinated Aromatic Hydrocarbons (Askarels) for Transformers	71
18. D 2521: Asphalt Used in Canal, Ditch and Pond Lining	71
19. D 2604: High-Boiling Hydrocarbon Solvent for Preparing Oil-Borne Preservative Solutions	71
20. D 2762: Drycleaning Detergent, Non-Charge Type	71
21. D 2763: Drycleaning Detergent, Liquid Charge Type	71
22. D 2880: Gas Turbine Fuel Oils	72
23. D 3141: Asphalt for Undersealing Portland Cement	72
24. D 3225: Low Boiling Hydrocarbon Solvent for Oil-Borne Preservatives	72
25. D 3320: Emulsified Coal-Tar Pitch (Mineral Colloid Type)	72
26. D 3487: Mineral Insulating Oil Used in Electrical Apparatus	73
27. D 3699: Kerosine	73
28. D 3734: High-Flash Aromatic Naphthas	73
29. D 3735: VM&P Naphthas	73
30. D 3757: Guide for Preparing Specifications for Solvent Floor Polishes	73
31. D 3955: Electrical Insulating Varnishes	74
32. D 4010: Waterless Hand Cleaner	74
33. D 4011: Lotion Soap	74
34. D 4022: Coal Tar Roof Cement	74
35. D 4293: Phosphate Ester Based Fluids for Turbine Lubrication	74
36. D 4304: Mineral Lubricating Oil Used in Steam or Gas Turbines	75
<b>Chapter 5: ASTM Fire Property Standards Relating to Flash Point</b>	76
1. D 2883: Reaction Threshold Temperature of Liquids and Solid Materials	76
2. D 4206: Sustained Burning of Liquid Mixtures by Setaflash Apparatus (Open-Cup)	77
3. D 4207: Sustained Burning of Low-Viscosity Liquid Mixture by the Wick Test	77
4. D 4359: Determining Whether a Material is a Liquid or a Solid	78
5. E 659: Test Method for Autoignition Temperature of Liquid Chemicals	78



6. E 681: Concentration Limits of Flammability of Chemicals	79
7. E 771: Spontaneous Heating Tendency of Materials	80
8. E 918: Standard Practice for Determining Limits of Flammability of Chemicals at Elevated Temperature and Pressure	80
9. E 1231: Temperature Limit of Flammability of Chemicals	81
<b>Chapter 6: Auxiliary ASTM Standards Used to Define Flammable and Combustible Liquids in Government Regulations</b>	83
1. D 86: Test Method for Distillation of Petroleum Products	83
2. D 88: Saybolt Viscosity	84
3. D 323: Vapor Pressure of Petroleum Products (Reid Method)	84
4. D 445: Kinematic Viscosity of Transparent and Opaque Liquids (and the Calculation of Dynamic Viscosity)	84
5. D 2170: Kinematic Viscosity of Asphalts (Bitumens)	85
6. D 2171: Viscosity of Asphalts by Vacuum Capillary Viscometer	86
PART II: U.S. STANDARDS, SPECIFICATIONS, CODES, REGULATIONS, AND TARIFFS (FEDERAL, STATE, AND MUNICIPAL)	
<b>Chapter 7: U.S. Federal Standards and Specifications</b>	89
1. Standards and Specifications of U.S. Government	89
2. U.S. Department of Defense Index of Specifications and Standards	89
<b>Chapter 8: Flash Point Standards of U.S. Standards Organization</b>	93
1. American National Standards Institute	93
2. American Boat and Yacht Council	93
3. American Association of Cereal Chemists	93
4. American Oil Chemists' Society	94
5. American Association of State Highway Transportation Officials	94
6. Chemical Specialties Manufacturers Association	94
7. Essential Oil Association of U.S.A.	94
8. Factory Mutual System	94
9. International Conference of Building Officials	94
10. National Fire Prevention Association	94
11. Underwriters Laboratories	95
<b>Chapter 9: U.S. Code and Tariff Writing Organizations</b>	96
1. Association of American Railroads	96
2. United Parcel Service	96
3. Building Officials and Code Administrators	96
3.1 Fire Prevention Code 1990	96
<b>Chapter 10: Local Governmental Regulations in the U.S. States and Municipalities</b>	96
1. State of Michigan	96
2. State of New Jersey	96
3. State of Ohio	96
4. Commonwealth of Pennsylvania	96
4.1 Law	98
4.2 Transportation	98
4.3 Labor Industrial	98
4.4 Environmental Resources	99

5. City of Baltimore	99
6. City of New York	100
6.1 Administrative Code	100
6.2 Regulations for Storage and Use of Chemicals, Acids, and Cases in University, College Hospital Research and Commercial Laboratories	100
7. City of Philadelphia	100
8. Baltimore County Fire Department	101
<b>Chapter 11: U.S. Governmental Regulatory Agencies—Governmental Regulations</b>	102
Introduction	102
1. 49 CFR, Part A, U.S. Department of Transportation, Research and Special Programs Administration (RSPA) (Subchapter C) Hazardous Materials Regulations	102
1.1 Matter Incorporated by Reference (171.1)	103
1.2 Definitions and Abbreviations (171.8)	104
1.3 General Information, Regulations and Definitions (RSPA)	105
1.4 Transitional Provisions for Implementing Requirements Based on the U.N. Recommendations (171.14), <b>Federal Register</b> (December 21, 1990)	105
1.5 Transitional Provisions for Implementing Requirements on the U.N. Recommendations, <b>Federal Register</b> (December 20, 1991)	106
1.6 Purpose and Scope (173.1)	106
1.7 Hazardous Materials Classes and Index to Hazard Class Definitions (173.2)	106
1.8 Classification of Materials Having More Than One Hazard (173.2a)	106
1.9 Precedence of Hazard Table (173.2b)	107
1.10 Subpart D—Definitions, Classification, Packing Group Assignments and Exceptions for Hazardous Materials Other Than Class 1 and Class 7	107
1.11 Appendix E to Part 173—Guidelines for the Classification and Packing Group Assignment of Class 4 Materials	111
1.12 Appendix F to Part 173—Guidelines for the Classification and Packing Group Assignment of Division 5.1 Materials	114
2. 46 CFR, U.S. Coast Guard	115
2.1 Bulk Shipments	115
2.2 Commercial Fishing—Vessels Used to Transport Petroleum Products	115
2.3 Hazardous Ships Stores (Part 147)	115
3. 33 CFR, U.S. Coast Guard, St. Lawrence Shipping	116
3.1 Navigation and Navigable Waters	116
4. 29 CFR, U.S. Department of Labor (Part B), Occupational Safety and Health Administration (OSHA)— Industrial Plants (Labor)	117
4.1 Flammable and Combustible Liquids (1910.106)	117
4.2 Hazard Communication (1910.1200)	117
4.3 Occupational Exposure to Hazardous Chemicals in Laboratories (1910.1450)	119
4.4 Shipyard Employment (1915)	119

**x CONTENTS**

5. 29 CFR, Construction Industry (Subchapter D)	120
5.1 Safety and Health Regulations for Construction Hazard Communications (1926)	120
6. 16 CFR, Consumer Product Safety Commission (Subchapter C)	120
6.1 Commercial Practices (1500)	120
7. 16 CFR, Flash Point Testing Procedures, CPSC Regulations	121
7.1 Tag Open-Cup Method (1500.43)	121
7.2 Method of Test for Flash Point of Volatile Flammable Materials (1500.43a)	122
7.3 Method for Determining Extremely Flammable and Flammable Solids (1500.44)	122
7.4 Method for Determining Extremely Flammable and Flammable Contents of Self-Pressurized Containers (1500.45)	123
7.5 Method for Determining Flash Point of Extremely Flammable and Flammable Contents of Self-Pressurized Containers (1500.45)	123
8. 40 CFR, U.S. Environmental Protection Agency (Part D)	123
8.1 Pesticides and Toxic Substances	123
8.2 Office of Solid Waste	124
PART III: FLASH POINT RELATED SPECIFICATIONS AND STANDARDS FROM OTHER COUNTRIES (NATIONAL GOVERNMENTS AND ORGANIZATIONS)	
<b>Chapter 12: Specifications of Other National Governments</b>	<b>127</b>
Introduction	127
Australia	127
Brazil	127
Canada	127
France	127
Japan	127
Peoples Republic of China	128
Sweden	128
United Kingdom	128
USSR	128
<b>Chapter 13: Flash Point Methods from National Standards Organizations of Other Countries</b>	<b>129</b>
Introduction	129
1. Australia	129
2. Austria	129
3. Bangladesh	129
4. Belgium	130
5. Canada	130
6. Peoples Republic of China	130
7. Republic of China (Taiwan)	130
8. Columbia	130
9. Czechoslovakia	130
10. Denmark	130
11. Ecuador	130
12. Egypt, Arab Republic of	130
13. France	130
14. Germany	131
15. Hungary	131
16. India	131

17. Indonesia	131
18. Iran	131
19. Iraq	131
20. Israel	131
21. Italy	132
22. Japan	132
23. Jordan	132
24. Kuwait	132
25. Mexico	132
26. The Netherlands	132
27. New Zealand	132
28. Saudi Arabia	132
29. Singapore	132
30. Republic of South Africa	133
31. Sweden	133
32. Switzerland	133
33. United Kingdom	133
34. USSR	134
35. Venezuela	134
36. Zimbabwe	134

## PART IV—INTERNATIONAL STANDARDS AND REGULATIONS

<b>Chapter 14: International Flash Point and Related Standards</b>	137
Introduction	137
1. ISO 412: Gum Spirit of Turpentine and Wood Turpentine's for Paints and Varnishes	138
2. ISO 1516: Paints, Varnishes, Petroleum and Related Products—Flash/No Flash-Closed Cup Equilibrium Method	138
3. ISO 1523: Paints, Varnishes, Petroleum and Related Products—Determination of Flash Point—Closed Cup Equilibrium Method	139
4. ISO 2592: Petroleum Products—Determination of Flash and Fire Points—Cleveland Open Cup Method	140
5. ISO 2719: Petroleum Products—Determination of Flash Point—Pensky Martens Closed Cup Method	140
6. ISO 3679: Paints, Varnishes, Petroleum and Related Products—Determination of Flash Point—Rapid Equilibrium Method	141
7. ISO 3680: Paints, Varnishes, Petroleum and Related Products—Determination of Flash Rapid Equilibrium Method	141
8. ISO 5280: Xylene for Industrial Use Specification	142
9. ISO 2431: Paints and Varnishes—Determination of Flow Time by Use of Flow Cups	142
<b>Chapter 15: Regulations of International Regulatory Agencies</b>	147
1. Recommendations of the United Nations Economic and Social Council (Orange Book)	147
1.1 Scope of the Recommendations	147
1.2 Principles Underlying the Regulations of the Transport of Dangerous Goods	147
1.3 Desirability of Uniformity at the World Level for All Modes of Transport	148
1.4 Classification and Definitions of Classes of Dangerous Goods	148

1.5 Special Recommendations Relating to Class 3 Inflammable Liquids	148
2. International Civil Aviation Organization	150
3. International Maritime Organization	150
3.1 International Maritime Dangerous Goods Code	150
3.2 Definitions of Class 3 Inflammable Liquids	151
3.3 Standardization of the Flash Point Test Method	151
4. European Highway and Rail Transport Committee of the United Nations	152
4.1 Definitions	152
4.2 Test for Determining Flash Point	152
4.3 Test for Determining Fluidity	153
5. European Economic Community, Commission of the European Communities	153
5.1 Introduction/Definitions	153
5.2 Flash Point Definitions	154
6. International Air Transport Association	154
APPENDICES	
<b>Appendix A: Regulatory and Non-Regulatory Agencies (Governmental and Civilian)</b>	159
A.1 U.S. Governmental Regulatory Agencies	159
A.2 U.S. Governmental Non-Regulatory Agencies	159
A.3 International Governmental Regulatory Organizations	159
A.4 United Nations Organizations of Experts on the Transportation of Dangerous Goods	160
A.5 International Non-Governmental Regulatory Organizations: International Air Transportation Association	160
A.6 U.S. State Regulatory and Enforcement Agencies for Hazardous Materials	160
A.7 Status of Federal Hazardous Materials Regulations	161
<b>Appendix B: U.S. Non-Governmental Standard, Code, and Tariff Writing Organizations</b>	162
B.1 Code and/or Tariff Writing Organizations	162
B.2 Building Code Organizations	162
B.3 Safety Organizations	162
B.4 Standards Organization Having Flash Point Standards	163
<b>Appendix C: National Standards Organizations of Other Countries</b>	164
C.1 ISO Members	164
C.2 ISO Correspondent Members	167

# Overview

At present, there is no single reference available on flash point standards and their relationship to regulations controlling hazardous materials. This manual provides such information. In addition, it gives information on the relationship between various national and international regulations using flash point to define flammable liquids.

During the last 15 years, there has been a continued major activity in regulations and flash point standards development worldwide to control the manufacturing, storage, shipment, and use of hazardous materials. With the advent of the U.S. Occupational Safety and Health Administration's use of the closed-cup flash point apparatus and the change in flash point method from the open to the closed-cup apparatus by the U.S. Department of Transportation, U.S. industry was required to do extensive flash point testing. This has continued with the addition of regulations to control the environment and will continue with the change from open to closed-cup apparatus in the U.S. Consumer Safety Product Commission regulations.

At present, efforts to make the United Nation's Recommendations on Transportation of Dangerous Goods the basis for worldwide standards and regulations are being considered. Thus, availability of information on worldwide standards and regulations becomes important.

This volume includes the eight full ASTM flash point standard test methods and excerpts of all other ASTM flash point standard test methods and specifications with complete alphanumeric and date designations. Furthermore, all the ASTM flash point standard test methods and specifications with their volume numbers are listed in Chapter 2.

Selected excerpts of regulations for control of flammable liquids as they apply to definitions, classification of, and exceptions to hazardous materials are quoted exactly. Those quoted are from the regulations of all U.S. Regulatory Agencies as specified in the U.S. Code of Federal Regulations and in the publications of the International Regulatory Bodies, such as the International Civil Aviation Organization and the International Maritime Organization. Although the open-cup method specified by the Consumer Product Safety Commission (CPSC) regulation is an old method, and since its use will be permitted even after the adoption of the closed-cup method, it is printed in its entirety.

This guide is as complete as possible, but may contain omissions. As always, ASTM welcomes constructive comments. These can be directed to the Chairman of the ASTM Coordinating Committee for Flash Point and Related Properties, ASTM, 1916 Race Street, Philadelphia, PA 19103.

*Harry A. Wray*  
*Editor*

# **Part I: ASTM Flash Point Standards**

# Flash Point History

## INTRODUCTION

In 1973, the ASTM Coordinating Committee for Flash Point and Related Properties was formed. From its beginning, the Committee's major objective was preparing information on flash point. It was felt that a compilation on flash point methods and Government regulations would be beneficial to the public. The Committee therefore authorized this manual of test methods including those issued by ASTM and other standards organizations. The manual was to include both national and international regulations, codes, and tariffs in which flash point is used to define the flammability hazards of liquids.

## 1. HISTORY OF FLASH POINT TESTING

Since the discovery of petroleum in the nineteenth century, there have been enacted laws, regulations, or codes to control the handling, use, and transportation of hazardous liquids. One method for determining the extent of the hazards was using the flash point of a liquid to define its hazard classification.

The main function of petroleum in the nineteenth century was to produce kerosene. It was used for light and heat. As there was little demand for the light ends of petroleum but a high demand for kerosene, unscrupulous dealers adulterated the kerosene with these more volatile fractions with their low flash potential. As a result, there was a rash of house fires in the United Kingdom (U.K.) and the United States (U.S.), producing a demand for laws or regulations to control the sale of kerosene.

The U.K. then enacted the Petroleum Act of 1862 that stated that a liquid having a flash point below 37.7°C (100°F) was flammable, but no method was prescribed to determine it. In 1879, the U.K. established the Abel Closed-Cup as the required apparatus and lowered the flash point for defining a flammable liquid to 22.7°C (73°F).

In the U.S., one of the first ordinances enacted was by the city of New Orleans in 1869; this ordinance defined as flammable those liquids having a flash point below 43.3°C (110°F) and required that they be labeled as flammable. In 1871, Congress enacted a law administered by the Coast Guard under the Secretary of the Treasury Department to provide for safe handling of hazardous materials aboard ships.

Following these regulations, most of the states enacted laws to control flammable liquids by use of flash point or fire point. By 1890, most of the nations of the world had laws governing hazardous liquids. At present, the U.S. government has four main agencies that regulate and control hazardous liquids. These are (1) U.S. Department of Trans-

portation (DOT), regulating the transportation of flammable liquids; (2) U.S. Department of Labor's Occupational Safety and Health Administration (OSHA), controlling the handling of liquids in the work place; (3) Consumer Product Safety Commission (CPSC), regulating the use of flammable liquids by the consumer; and (4) Environmental Protection Agency (EPA), regulating hazardous liquids in the environment.

## 2. HISTORY OF ASTM FLASH POINT STANDARDS

Twenty years after the founding of ASTM as the American Section of the International Association for Testing Materials in 1898, the first ASTM flash point standard was approved. The Tag closed-cup method was published in 1918 as ASTM D 56-18T. Presuming that the development of a standard takes about two years from conception to its final approval, first work on an ASTM flash point standard was started about 1916. Until recently, it was under the joint jurisdiction of ASTM Committees D 1 on Paint and Related Coatings and Materials, and D 2 on Petroleum Products and Lubricants. It is now under the sole jurisdiction of ASTM Committee D 2.

Note that, while the open-cup methods for flash and fire points were widely specified in individual state laws from about 1890, the first standardized method by ASTM was a closed-cup method.

The first open-cup standard approved by ASTM was ASTM D 92, Test Method Flash and Fire Points by Cleveland Open-Cup, which was published in 1921, three years after D 56 was approved. In the same year, ASTM D 93, Test Methods for Flash Point by Pensky-Martens Closed Tester, was approved.

While federal, state, and local governments used open-cup flash point methods in regulations controlling the manufacture, labeling, storage, transportation, and use of flammable liquids during the first half of the twentieth century, it was not until 1921 that ASTM D 1310, Test Method for Flash Point and Fire Points of Liquids by Tag Open-Cup Apparatus, was approved. In the meantime, the U.S. Interstate Commerce Commission (ICC), which regulated the shipment of hazardous substances before the formation of the U.S. DOT, specified the Tag open-cup method in their regulations. The U.S. Food and Drug Administration (FDA) was required to define flammable and combustible liquids by the Tag open-cup method. Later, the U.S. (CPSC) administered what became the Federal Hazardous Substance Act. In 1970, the U.S. Congress established the OSHA. In 1971, OSHA proposed regulations governing flammable liquids



## 4 FLASH POINT STANDARDS AND THEIR USE

based on the National Fire Protection Association's (NFPA) Code 30 that classifies these liquids using closed-cup methods. These regulations became effective in 1972. The U.S. DOT also proposed similar regulations which became effective in 1976. The U.S. EPA then adopted the Setaflash closed-cup method to determine the ignitibility of solid waste. In 1978, the Federal Hazardous Substance Act was amended to remove this Setaflash method from the act and to empower the CPSC to define flammable and combustible liquids by the best available method. In 1987, the CPSC changed the method used for classifying flammable liquids from the Tag open-cup method to the Setaflash method.

Meanwhile in 1973, two new closed-cup methods were published using the British developed instrument, the Setaflash Closed-Cup Tester. Method D 3243, Flash Point of Aviation Turbine Fuels by Setaflash Closed Tester, was issued by ASTM Committee D 2, and D 3278, Test Methods for Flash Point of Liquids by Setaflash-Closed-Cup Apparatus, by Committee D 1.

In 1979, ASTM developed D 3828, Test Method for Flash Point by Setaflash Closed Tester, jointly with the Institute of Petroleum. Thereafter, D 3243 was withdrawn as an active standard.

Following the advent of the Setaflash methods which use an equilibrium procedure, International Standards Organization/Technical Committee 35 (ISO/TC), Paints and Varnishes, and ISO/TC 28 Petroleum and Related Products developed two methods using that procedure and a regular flash point apparatus. Based on these ISO methods, ASTM in 1980, approved D 3934, Method for Determination of Flash/No Flash of Liquids by the Close Cup Method and D 3941, Test Method for Flash Point by the Equilibrium Closed-Cup Method.

## 3. FLASH POINT BASICS

The following definitions and significance and use statements are combined from ASTM flash point standard test methods to provide the reader with a basis of what this guide is about.

### Definition of Flash Point

*Flash point*—the lowest temperature, corrected to a pressure of 760 mm Hg (101.3kPa) (1013 mbar), at which application of an ignition source causes the vapor of a specimen to ignite.

### Significance and Use

Flash point is an indication of the temperature at which sufficient flammable vapors are evolved from a material to produce an ignition and propagation of a flame upon application of an ignition source. It can be used by regulatory agencies to classify the flammability properties according

to their flash points. Liquids are generally classified as "extremely flammable," "flammable," and "combustible," and by some agencies as "ignitable." These agencies specify various regulations for transportation, storage, and use of liquid materials based on these classes of flammable liquids. Types of containers, placards and labels, and directions for storage are indicated for each class.

Flash points can be used as an indication of the presence of volatile impurities in a low vapor pressure material. For example, a low flash point in kerosene may be an indication of the presence of gasoline as an impurity. Also, a low flash point for a heat transfer fluid or for other process liquids may be an indication of the presence of low molecular weight decomposition products in the original material.

Flash point can be used as a general indication of the volatility of hydrocarbon fractions and, therefore, be used as one test for the suitability of hydrocarbon blends for jet fuels, oil burner fuels, or internal combustion engine fuels.

Flash point, as determined by standard tests, is apparatus dependent and may not represent the absolute minimum temperatures at which a material may evolve flammable vapors.

Some mixed materials that will not burn in the open, materials that could even function as fire extinguishing agents, may have a flash point (dilute alcohol-water mixtures).

Some materials having no flash point may evolve vapors that are flammable in large vessels (trichloroethane, trichloroethylene) or vapors that are flammable under conditions of superheating and adequate mixing (methylene chloride).

### Definition of Fire Point

*Fire point*—the lowest temperature at which a specimen will sustain burning for 5 s under specified conditions of test.

### Flash Point Methods (ASTM)

ASTM standards involving the measurement of the flash point of materials, liquids, and solids can be divided into three general categories: (1) basic standard methods; (2) standard methods, guides, and practices using the basic methods with or without modifications to suit the needs of a particular product or type of product; and (3) standard specifications for defining the properties of a material in which the flash point is listed as one of the properties of the material.

## REPRINT OF THE EIGHT BASIC ASTM FLASH POINT STANDARD METHODS

The eight basic flash point methods are reprinted in numerical order on the following pages.

# ASTM Basic Flash Point Standards

## INTRODUCTION

There are eight basic ASTM standard flash point test methods frequently referenced throughout this manual as follows:

1. D 56-87—Test Method for Flash Point by Tag Closed Tester.
2. D 92-85—Test Method for Flash and Fire Points by Cleveland Open Cup.
3. D 93-85—Test Method for Flash Point by Pensky-Martens Closed Tester.
4. D 1310-86—Test Method for Flash Point and Fire Point of Liquids by Tag Open-Cup Apparatus.
5. D 3278-82—Test Methods for Flash Point of Liquids by Setaflash Closed-Cup Apparatus.

6. D 3828-87—Flash Point by Setaflash Closed Tester.

7. D 3934-84—Test Method for Flash/No Flash Test—Equilibrium Method by Closed-Cup Apparatus.

8. D 3941-84—Test Method for Flash Point by the Equilibrium Method With a Closed-Cup Apparatus.

All eight of these test methods are reprinted in this chapter. To further aid reader referencing of important flash point information, Table 2-1 precedes the full test methods, and provides useful repeatability and reproducibility values for each of the ASTM flash point test methods. Precision values for D 3934 are not included, however, because they are not available as of the date of this publication.

TABLE 2-1—Comparison of ASTM flash point test method precision values.

Test Method/Vol No.	Applicable Material	Flash Point Values, °C (°F)	Repeatability Values, °C (°F)	Reproducibility Values, °C (°F)
OPEN CUPS				
D 92/05.01	...	all values	8 (15)	17 (30)
D 1310/05.01	...	(-18)–93 (0–200)	2 (4)	4 (7)
		93–165 (200–325)	5 (9)	7 (12)
	viscous or pigmented	all values	5 (9)	13 (24)
CLOSED CUPS				
D 56/05.01	...	below 13 (55)	...	3.3 (6)
		13–59 (55–139)	1.1 (2)	2.2 (4)
		60–93 (140–199)	1.7 (3)	3.3 (6)
D 93/05.01	suspensions of solids	35–43 (95–110)	2 (4)	3.5 (6)
(method A)	all other materials	under 104 (220)	2 (4)	3.5 (6)
		above 104 (220)	5.5 (10)	8.5 (15)
D 93/05.01	viscous or pigmented	all values	5 (9)	10 (18)
(method B)				
D 3278/06.03	liquids at or below 45 SUS	37.8 (100)	1.7 (3)	3.3 (6)
	liquids above 45 SUS or with dispersed solids	37.8 (100)	3.3 (6)	3.5 (9)
D 3828/05.03 <sup>a</sup>	...	20–70°C	0.5°C	0.03(M + 29)°C
		68–158°F	0.9°F	0.03(M + 22)°F
		above 70°C	0.022M0.9°C	0.083M0.9°C
		above 158°F	(0.0117M)°F	(0.045M)°F <sup>†</sup>
D 3941/06.03	...	all values	2 (3.5)	3 (5.0)
(ISO Data)				

<sup>a</sup>M is the mean of two results in °C or °F.



# Standard Test Method for Flash Point by Tag Closed Tester<sup>1</sup>

This standard is issued under the fixed designation D 56; the number immediately following the designation indicates the year of original adoption or, in the case of revision, the year of last revision. A number in parentheses indicates the year of last reapproval. A superscript epsilon ( $\epsilon$ ) indicates an editorial change since the last revision or reapproval.

*This test method has been adopted for use by government agencies to replace Method 1101 of Federal Test Method Standard No. 791b, and Method 4291 of Federal Test Method Standard No. 141A.*

## 1. Scope

1.1 This test method covers the determination of the flash point, by Tag closed tester, of liquids with a viscosity of below 5.5 centistokes (cSt) at 104°F (40°C), or below 9.5 cSt at 77°F (25°C), and a flash point below 200°F (93°C) except cut-back asphalts, those liquids which tend to form a surface film under test conditions, and materials which contain suspended solids.

NOTE 1—For the closed-cup flash point of liquids with a viscosity of 5.5 cSt or more at 104°F (40°C), or 9.5 cSt or more at 77°F (25°C), with a flash point of 200°F (93°C) or higher, which tend to form a surface film under test conditions, or suspensions of solids, use Method D 93. For cut-back asphalts refer to Methods D 1310 and D 3143.

NOTE 2—The U. S. Department of Transportation (RSTA)<sup>2</sup> and U. S. Department of Labor (OSHA) have established that liquids with a flash point under 100°F (37.8°C) are flammable as determined by this method for those liquids which have a viscosity less than 5.5 cSt at 104°F (40°C), or 9.5 cSt or less at 77°F (25°C), or do not contain suspended solids or do not have a tendency to form a surface film while under test. Other classification flash points have been established by these Departments for liquids using this test.

1.2 Liquids having viscosities more than 5.5 cSt at 104°F (40°C), or 9.5 cSt or more at 77°F (25°C), and contain suspended solids or have a tendency to form a surface film while under test should be tested in accordance with Test Methods D 93.

1.3 The values stated in inch-pound units are to be regarded as the standard. Temperatures are in degrees Fahrenheit and viscosity is in Centistokes units. The values in parentheses are for information only.

1.4 *This standard should be used to measure and describe the properties of materials, products, or assemblies in response to heat and flame under controlled laboratory conditions and should not be used to describe or appraise the fire hazard or fire risk of materials, products, or assemblies under actual fire conditions. However, results of this test may be used as elements of fire risk assessment which takes into account all of the factors which are pertinent to an assessment of the fire hazard of a particular end use.*

1.5 *This standard may involve hazardous materials, operations, and equipment. This standard does not purport to address all of the safety problems associated with its use. It is the responsibility of the user of this standard to establish appropriate safety and health practices and determine the applicability or regulatory limitations prior to use. For specific hazard statements, see Note 5.*

1.6 Related Standards are Test Methods D 93, D 3828 and D 3941.

## 2. Referenced Documents

### 2.1 ASTM Standards:

- D 93 Test Methods for Flash Point by Pensky-Martens Closed Tester<sup>3</sup>
- D 850 Method for Distillation of Industrial Aromatic Hydrocarbons and Related Materials<sup>4</sup>
- D 1015 Test Method for Freezing Points of High-Purity Hydrocarbons<sup>3</sup>
- D 1078 Test Method for Distillation Range of Volatile Organic Liquids<sup>4</sup>
- D 1310 Test Method for Flash Point and Fire Points of Liquids by Tag Open-Cup Apparatus<sup>3</sup>
- D 3143 Test Method for Flash Point of Cutback Asphalt with Tag Open-Cup Apparatus<sup>5</sup>
- D 3828 Test Method for Flash Point by Setaflash Closed Tester<sup>6</sup>
- D 3941 Test Method for Flash Point by the Equilibrium Method with a Closed-Cup Apparatus<sup>4</sup>
- E 1 Specification for ASTM Thermometers<sup>7</sup>

## 3. Definition

3.1 *flash point*—the lowest temperature corrected to a pressure of 760 mm Hg (101.3 kPa, 1013 m bar) at which application of a test flame causes the vapors of a portion of the sample to ignite under specified conditions of test.

## 4. Summary of Test Method

4.1 The sample is placed in the cup of the tester and, with the lid closed, heated at a slow constant rate. A small flame of specified size is directed into the cup at regular intervals. The flash point is taken as the lowest temperature at which application of the test flame causes the vapor above the sample to ignite.

<sup>1</sup> This test method is under the joint jurisdiction of ASTM Committee D-2 on Petroleum Products and Lubricants and is the direct responsibility of Subcommittee D 02.08 on Volatility.

Current edition approved Dec. 14, 1987. Published February 1988. Originally published as D 56 – 18 T. Last previous edition D 56 – 82.

<sup>2</sup> For information on U. S. Department of Transportation's regulations, see Codes of U. S. Regulations 49 CFR Chapter 1 and for information on U. S. Department of Labor's regulations see Code of U. S. Regulations 29 CFR Chapter XVII. Each of these items are revised annually and may be procured from the Superintendent of Documents, Government Printing Office, Washington, DC 20402.

<sup>3</sup> *Annual Book of ASTM Standards*, Vol 05.01.

<sup>4</sup> *Annual Book of ASTM Standards*, Vol 06.03.

<sup>5</sup> *Annual Book of ASTM Standards*, Vol 04.03.

<sup>6</sup> *Annual Book of ASTM Standards*, Vol 05.03.

<sup>7</sup> *Annual Book of ASTM Standards*, Vols 05.01 and 14.03.

## 5. Significance and Use

5.1 Flash point measures tendency of the sample to form a flammable mixture with air under controlled laboratory conditions. It is only one of a number of properties that must be considered in assessing the overall flammability hazard of a material.

5.2 Flash point is used in shipping and safety regulations to define "flammable" and "combustible" materials. One should consult the particular regulation involved for precise definitions of these classes.

5.3 Flash point can indicate the possible presence of highly volatile and flammable materials in a relatively nonvolatile or nonflammable material. For example, an abnormally low flash point on a sample of kerosine may indicate gasoline contamination.

## 6. Apparatus

6.1 *Tag Closed Tester*—The apparatus is shown in Fig. 1 and described in detail in Annex A1. Refer to Annex A2 for

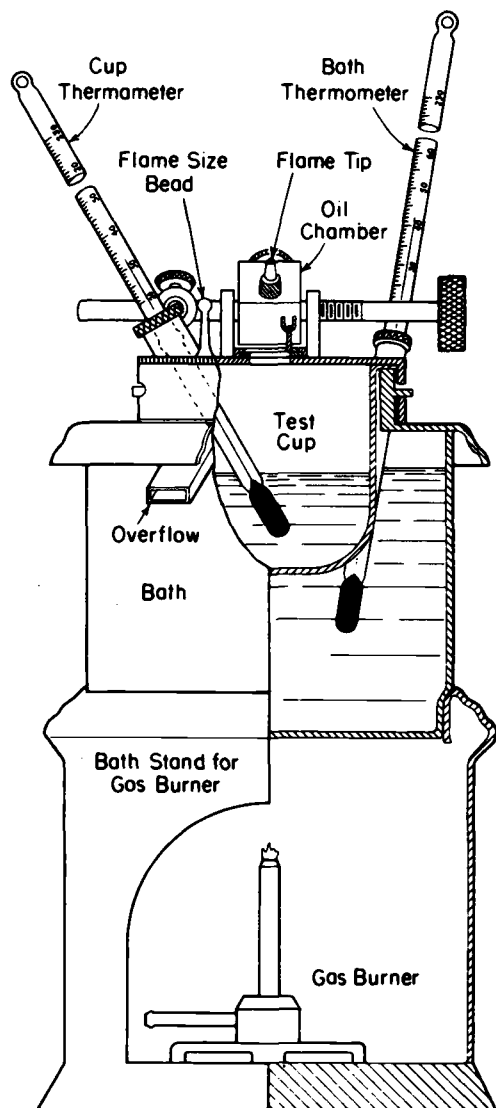

FIG. 1 Tag Closed Flash Tester

directions for checking the condition and operation of the tester.

6.2 *Shield*—A shield 18 in. (460 mm) square and 24 in. (610 mm) high, open in front, is recommended.

6.3 *Thermometers*—For the test cup thermometer, use one as prescribed in Table 1. For the bath thermometer, any convenient type that has an adequately open scale covering the required range may be used; it is often convenient to use the same type of thermometer as used in the test cup.

NOTE 3—Whenever thermometers complying with ASTM requirements are not available, thermometers complying with the requirements for The Institute of Petroleum thermometer IP 15F PM-Low may be used.

NOTE 4—There are automatic flash point testers available and in use which may be advantageous in that they save testing time, permit the use of small samples, and exhibit other factors which may merit their use. When automatic testers are used, the user must be sure that all of the manufacturer's instructions for calibrating, adjusting, and operating the instrument are followed. In any case of dispute, the flash point as determined manually shall be considered the referee test.

## 7. Sample

7.1 Erroneously high flash points can be obtained when precautions are not taken to avoid the loss of volatile material. Containers shall not be opened unnecessarily and transfers shall not be made unless the sample temperature is at least 20°F (11°C) below the expected flash point. Samples in leaky containers shall be discarded.

7.2 Samples are not to be stored in plastic (polyethylene, polypropylene, etc.) bottles, since volatile material may diffuse through the walls of the bottle.

## 8. Preparation of Apparatus

8.1 Support the tester on a level steady table. Unless tests are made in a draft-free room or compartment, surround the tester on three sides by the shield for protection from drafts. Tests are not to be made in a laboratory draft hood or near ventilators.

8.2 Gas is recommended for the test flame.

## 9. Procedure

9.1 For flash points below 55°F (13°C) or above 140°F (60°C), use as bath liquid a 1+1 mixture of water and ethylene glycol (see Warning—see Note 5). For flash points between 55°F (13°C) and 140°F (60°C), either water or a water-glycol mixture may be used as bath liquid (Note 5). The temperature of the liquid in the bath shall be at least 20°F (11°C) below the expected flash point at the time of introduction of the sample into the test cup. Do not cool bath liquid by direct contact with dry ice (solid carbon dioxide). Place the test cup in position in the bath.

NOTE 5: *Precaution*—Although ethylene glycol is considered low in oral toxicity, nonirritating to the skin, and appears to be no respiratory hazard during normal handling, caution should be exercised when using

TABLE 1 Thermometers

For Tests	Below 40°F (4°C)	At 40 to 120°F (4 to 49°C)	Above 120°F (49°C)
Use ASTM Thermometer <sup>A</sup>	57F or 57C	9F or 9C 57F or 57C	9F or 9C

<sup>A</sup> Complete specifications for these thermometers are given in Specification E 1.

it. The operator must avoid oral ingestion of the liquid, inhalation of large quantities of vapors, and contact of the liquid with the eyes or extended areas of the skin.

NOTE 6—Due to possible difficulty in maintaining the prescribed rate of temperature rise and due to the formation of ice on the lid, results by this method for samples having flash points below 32°F (0°C) may be somewhat unreliable. Trouble due to ice formation on the slide may be minimized by carefully lubricating the slide shutter with high-vacuum silicone lubricant.

9.2 Using a graduate and taking care to avoid wetting the cup above the final liquid level, measure  $50 \pm 0.5$  mL of the sample into the cup, both the sample and graduate being precooled, if necessary, so that the sample temperature at the time of measurement will be  $80 \pm 10^\circ\text{F}$  ( $27 \pm 5^\circ\text{C}$ ) or at least  $20^\circ\text{F}$  ( $11^\circ\text{C}$ ) below the expected flash point, whichever is lower. It is essential that the sample temperature be maintained at least  $20^\circ\text{F}$  ( $11^\circ\text{C}$ ) below the expected flash point during the transfers from the sample container to the graduate and from the graduate to the test cup. Destroy air bubbles on the surface of the sample. Wipe the inside of the cover with a clean cloth or absorbent tissue paper; then attach the lid, with the thermometer in place, to the bath collar.

9.3 Light the test flame, adjusting it to the size of the small bead on the cover. Operate the mechanism on the cover in such a manner as to introduce the test flame into the vapor space of the cup, and immediately bring it up again. The time consumed for the full operation shall be about 1 s, or the time required to pronounce distinctly the words "thousand and one." Avoid any jerkiness in the operation of depressing and raising the test flame.

9.4 *Flash Points Below 140°F (60°C)*—When the flash point of the sample is known to be below  $140^\circ\text{F}$  ( $60^\circ\text{C}$ ), apply and adjust the heat so that the temperature of the portion will rise at a rate of  $2^\circ\text{F}$  ( $1^\circ\text{C}$ )/min  $\pm 6$  s. When the temperature of the portion in the test cup is  $10^\circ\text{F}$  ( $5^\circ\text{C}$ ) below its expected flash point, apply the test flame in the manner just described in 9.3, and repeat the application of the test flame after each  $1^\circ\text{F}$  ( $0.5^\circ\text{C}$ ) rise in temperature of the portion.

9.5 *Flash Points at or Above 140°F (60°C)*—If the flash point of the sample is known to be  $140^\circ\text{F}$  ( $60^\circ\text{C}$ ) or higher, apply and adjust the heat so that the temperature of the portion will rise at a rate of  $5^\circ\text{F}$  ( $3^\circ\text{C}$ )/min  $\pm 6$  s. When the temperature of the portion in the test cup is  $10^\circ\text{F}$  ( $5^\circ\text{C}$ ) below its expected flash point, apply the test flame in the manner described in 9.3 and repeat the application of the test flame each  $2^\circ\text{F}$  ( $1^\circ\text{C}$ ) rise in temperature of the portion, at each temperature reading that is a multiple of  $2^\circ\text{F}$  ( $1^\circ\text{C}$ ).

9.6 When the test flame application causes a distinct flash in the interior of the cup, observe and record the temperature of the portion as the flash point. Do not confuse the true flash with the bluish halo which sometimes surrounds the test flame during applications immediately preceding the actual flash.

9.7 Discontinue the test and remove the source of heat. Lift the lid and wipe the thermometer bulb. Remove the sample cup, empty, and wipe dry.

9.8 If, at any time between the first introduction of the test flame and the observation of the flash point, the rise in temperature of the portion is not within the specified rate or if the actual flash point differs from the expected flash point

by an amount greater than  $4^\circ\text{F}$  ( $2^\circ\text{C}$ ), discard the result and repeat the test, adjusting the source of heat to secure the proper rate of temperature rise, or using a modified "expected flash point," or both, as required.

NOTE 7—Never make a repeat test on the same portion of sample; always take a fresh portion of sample for each test.

## 10. Correction for Barometric Pressure

10.1 Observe and record the ambient barometric pressure (Note 8) at the time of the test. When the pressure differs from 760 mm Hg (101.3 kPa), correct the flash point as follows:

- (A) Corrected flash point =  $C + 0.25(101.3 - p)$
- (B) Corrected flash point =  $F + 0.06(760 - P)$
- (C) Corrected flash point =  $C + 0.033(760 - P)$

where:

- $F$  = observed flash point, °F,
- $C$  = observed flash point, °C,
- $P$  = ambient barometric pressure, mm Hg, and
- $p$  = ambient barometric pressure, kPa.

NOTE 8—The barometric pressure used in this calculation must be the ambient pressure for the laboratory at the time of test. Many aneroid barometers, such as those used at weather stations and airports, are precorrected to give sea level readings; these must not be used.

10.2 Record the corrected flash point to the nearest  $1^\circ\text{F}$  (or  $0.5^\circ\text{C}$ ).

## 11. Precision and Bias<sup>8</sup>

11.1 *Precision*—The following criteria should be used for judging the acceptability of results (95 % probability):

11.1.1 *Repeatability*—The difference between successive test results, obtained by the same operator with the same apparatus under constant operating conditions on identical test material, would in the long run, in the normal and correct operation of the test method, exceed the following values only in one case in twenty:

Flash Point, °F (°C)	Repeatability, °F (°C)
Below 140 (60)	2 (1.1)
140 (60) to 199 (93)	3 (1.7)

11.1.2 *Reproducibility*—The difference between two single and independent results, obtained by different operators working in different laboratories on identical test material, would in the long run, in the normal and correct operation of the test method, exceed the following values only in one case in twenty:

Flash Point, °F (°C)	Reproducibility, °F (°C)
Below 55 (13)	6 (3.3)
55 (13) to 139 (59)	4 (2.2)
140 (60) to 199 (93)	6 (3.3)

11.2 *Bias*—The procedure in Test Method D 56 for measuring flash point can be defined only in terms of a test method.

<sup>8</sup> Supporting data are available from ASTM Headquarters. Request RR: D2-1003.

ANNEXES

(Mandatory Information)

A1. APPARATUS

A1.1 The Tag closed tester shall consist of the test cup, lid with test flame, and liquid bath conforming to the following requirements:

A1.1.1 *Test Cup*, of brass or other nonrusting metal of equivalent heat conductivity, conforming to dimensional requirements prescribed in Table A1.1. It shall weigh  $68 \pm 1$  g.

A1.1.2 *Lid*:

A1.1.2.1 The lid comprises a circle of nonrusting metal with a rim projecting downward about  $\frac{5}{8}$  in. (15.9 mm), a slide shutter, a device which simultaneously opens the shutter and depresses the tip of the tube which carries fuel through to the test flame, and a slanting collar in which the cup-thermometer ferrule is inserted. Figure A1.1 gives a diagram of the upper surface of the lid, showing dimensions and positions of the three holes opened and closed by the shutter, and the size and position of the opening for the cup thermometer.

A1.1.2.2 The rim shall fit the collar of the liquid bath with a clearance not exceeding 0.002 in. (0.05 mm) and shall be slotted in such a manner as to press the lid firmly down on the top of the cup when the latter is in place in the bath. When this requirement is not met, the vertical position of the cup in the bath shall be suitably adjusted, as by placing a thin ring of metal under the flange of the cup.

A1.1.2.3 The shutter shall be of such size and shape that it covers the three openings in the lid when in the closed position and uncovers them completely when in the open position. The nozzle of the flame-exposure device shall conform to the dimensions given in Table A1.1. The device shall be designed and constructed so that opening the shutter depresses the tip to a point approximately 0.08 in. (2 mm) to the right of the horizontal center of the middle opening of the lid (Refer to lower part of Fig. A1.2). This will bring the test flame to the approximate center of the opening. The plane of the underside of the lid shall be between the top and bottom of the opening in the tip of the flame-exposure device

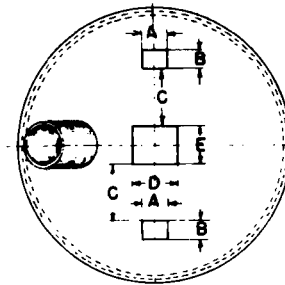

- A - 0.281"
- B - 0.188"
- C - 0.594"
- D - 0.469"
- E - 0.406"

Note: All dimensions  $\pm 0.005$ " unless otherwise shown.

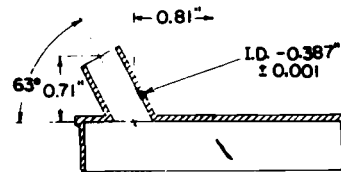

TOP OF LID SHOWING POSITION AND DIMENSIONS OF OPENINGS

Metric Equivalents

in.	mm	in.	mm
0.001	0.03	0.406	10.32
0.005	0.13	0.469	11.92
0.188	4.78	0.594	15.10
0.281	7.15	0.71	18.0
0.387	9.84	0.81	20.6

NOTE—Dimensions relating to the size and position of the thermometer collar are recommended but not mandatory.

FIG. A1.1 Top of Lid Showing Position and Dimensions of Openings

when the latter is fully depressed.

A1.1.2.4 The collar for the cup-thermometer ferrule shall be set at an angle which permits placement of the thermometer with its bulb approximately in the horizontal center of the cup, at a depth prescribed in Table A1.1.

A1.1.3 *Liquid Bath*, conforming to the limiting or minimum dimensions shown in Fig. A1.2. It shall be of brass, copper, or other noncorroding metal of substantial construction. Sheet metal of about No. 20 B & S gage (0.812 mm) is satisfactory. It may, if desired, be lagged with heat-insulating material to facilitate control of temperature.

A1.1.4 *Heater*, of any type (electric, gas, alcohol, etc.) capable of controlling temperature as required in Section 8. An external electric heater, controlled by a variable voltage transformer, is recommended.

TABLE A1.1 Dimensional Requirements

Depth of bath liquid surface below top of test cup	1.094 $\pm$ 0.016 in. (27.8 $\pm$ 0.4 mm)
Depth of sample surface below top of test cup	1.156 $\pm$ 0.031 in. (29.4 $\pm$ 0.8 mm)
Depth of bottom of bulb of test thermometer below top of cup when in place	1.77 $\pm$ 0.03 in. (45.0 $\pm$ 0.8 mm)
Inside diameter of test cup at top	2.125 $\pm$ 0.005 in. (54.0 $\pm$ 0.1 mm)
Diameter of bead on top of cover	0.156 $\pm$ 0.031 in. (4.0 $\pm$ 0.8 mm)
Diameter of opening in tip of test flame nozzle	0.049 $\pm$ 0.010 in. (1.2 $\pm$ 0.3 mm)
Outside diameter of tip of test flame nozzle	0.079 in. max (2.0 mm max)

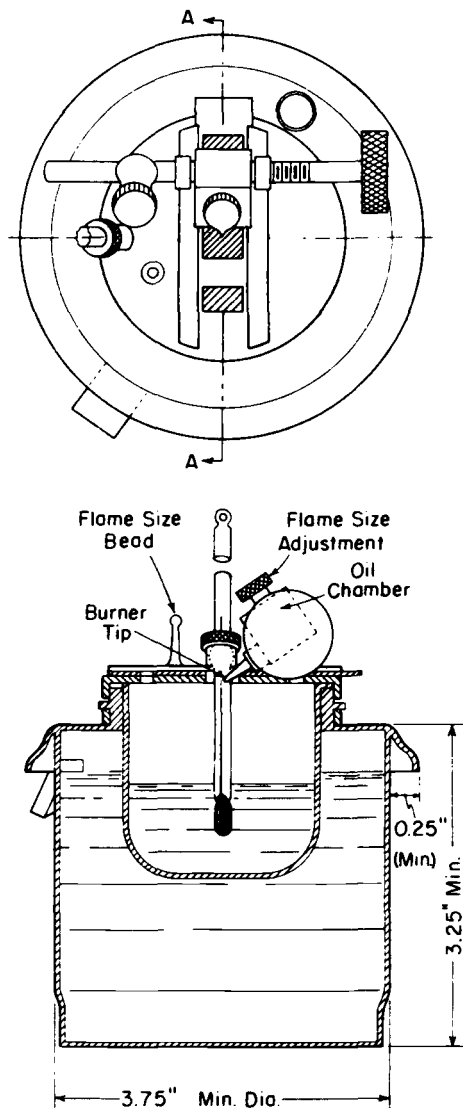

**Metric Equivalents**

in.	0.25	3.25	3.75
mm	6.4	82.6	95.3

**FIG. A1.2 Section of Liquid Bath and Cup**

A1.1.5 *Bath Stand*—For electric heating, any type of stand may be used. For alcohol lamp or gas burner, a stand,

as illustrated in Fig. 1, to protect the flame from air currents (unless tests can be made in a draft-free room) is required.

**A2. CHECKING CONDITION AND OPERATION OF TAG CLOSED TESTERS**

**A2.1 Material**

A2.1.1 *p-Xylene*,<sup>9</sup> conforming to the following requirements:

Specific gravity (60/60°F) (15.6/15.6°C), 0.860 min, 0.866 max.

Boiling range. . . .2°C max from start to dry point, when tested by Test Method D 850 or Test Method D 1078. The

range shall include the boiling point of pure *p-xylene*, which is 281°F (138.4°C).

Freezing point. . . .52.2°F (11.23°C), min (95 % molal purity) as determined by Method D 1015.

**A2.2 Procedure**

A2.2.1 Determine the flash point of the *p-xylene*, following the directions in Sections 6 to 9. When the tester is operating properly, a value of 81 ± 1°F (27.2 ± 0.6°C) will be obtained.

<sup>9</sup> Available as Flash Point Check Fluid (*p-xylene*) from Special Products Div., Phillips Petroleum Co., Drawer O, Borger, TX 79007.

A2.2.2 When the flash point obtained on *p*-xylene is not within the limits stated in A2.2.1, check the condition and operation of the apparatus to ensure conformity with the details listed in Annex A1, especially with regard to tightness of the lid (A1.1.2.2), the action of the shutter and the

position of the test flame (A1.1.2.3), and the angle and position of the thermometer (A1.1.2.4). After adjustment, when necessary, repeat the test, with special attention to procedural details prescribed in Section 8.

### A3. MANUFACTURING STANDARDIZATION

A3.1 The cup thermometer, which conforms also to the specifications for the low-range thermometer used in the Pensky-Martens flash tester, Method D 93, is frequently supplied by the thermometer manufacturer with a metal or polytetrafluoroethylene ferrule intended to fit the collar on the lid of the flash tester. This ferrule is frequently supplemented by an adapter which is used in the larger-diameter collar of the Pensky-Martens apparatus. Differences in dimensions of these collars, which are immaterial in their

effect on the result of tests, are a source of considerable unnecessary trouble to manufacturers and suppliers of instruments, as well as to users.

A3.2 Subcommittee 21 on Metalware Laboratory Apparatus, of ASTM Committee E-1 on Methods of Testing, has studied this problem and has established some dimensional requirements which are shown, suitably identified, in Figs. A1.1, A3.1, and A3.2. Conformity to these requirements is not mandatory but is desirable to users as well as suppliers of Tag closed testers.

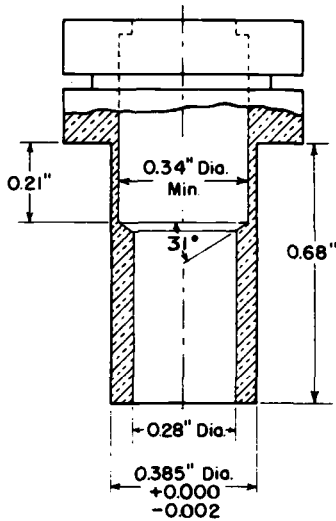

in.	mm	in.	mm
0.002	0.05	0.34	8.6
0.21	5.3	0.385	9.8
0.28	7.1	0.68	17.3

FIG. A3.1 Dimensions for Thermometer Ferrule (Not Mandatory)

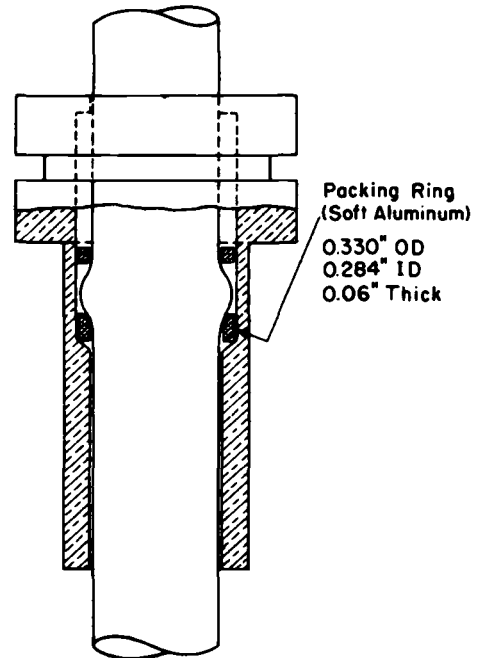

in.	mm	0.06	0.284	0.330
		1.5	7.23	8.40

FIG. A3.2 Dimensions for Thermometer Packing Ring (Not Mandatory)

The American Society for Testing and Materials takes no position respecting the validity of any patent rights asserted in connection with any item mentioned in this standard. Users of this standard are expressly advised that determination of the validity of any such patent rights, and the risk of infringement of such rights, are entirely their own responsibility.

This standard is subject to revision at any time by the responsible technical committee and must be reviewed every five years and if not revised, either reapproved or withdrawn. Your comments are invited either for revision of this standard or for additional standards and should be addressed to ASTM Headquarters. Your comments will receive careful consideration at a meeting of the responsible technical committee, which you may attend. If you feel that your comments have not received a fair hearing you should make your views known to the ASTM Committee on Standards, 1916 Race St., Philadelphia, PA 19103.





Designation: D 92 – 90



Designation: 36/84

An American National Standard  
American Association State  
Highway and Transportation Officials Standard  
AASHTO No.: T48  
DIN 51 376

## Standard Test Method for Flash and Fire Points by Cleveland Open Cup<sup>1</sup>

This standard is issued under the fixed designation D 92; the number immediately following the designation indicates the year of original adoption or, in the case of revision, the year of last revision. A number in parentheses indicates the year of last reapproval. A superscript epsilon ( $\epsilon$ ) indicates an editorial change since the last revision or reapproval.

*This test method was adopted as a joint ASTM-IP standard in 1965.*

*This test method has been adopted for use by government agencies to replace Method 1103.7 of Federal Test Method Standard No. 791b, and Method 4294 of Federal Test Method Standard No. 141A.*

### INTRODUCTION

This flash and fire points method depends on definite rates of temperature increases to control the precision of the method. It is a non-equilibrium method. Its primary use is for viscous materials having a flash point of 79°C (175°F) and above. It is also used to determine fire point which is a temperature above the flash point temperature, at which the sample will support combustion for at least 5 s. Do not confuse with Test Method D 4206 which is a sustained burning test, open cup type, at a specific temperature, 49°C (120°F).

#### 1. Scope

1.1 This test method covers determination of the flash and fire points of all petroleum products except fuel oils and those having an open cup flash below 79°C (175°F).

1.2 The values stated in SI units are to be regarded as the standard. Values in parentheses are provided for information only.

NOTE 1—It is the practice in the United Kingdom and in many other countries to use IP Method 35, unless Test Methods D 93 – IP 34 is specified. This test method is occasionally specified for the determination of the fire point of a fuel oil. For the determination of the flash points of fuel oils, use Test Methods D 93 – IP 34. Test Methods D 93 – IP 34 should also be used when it is desired to determine the possible presence of small but significant concentrations of lower flash point substances which can escape detection by Test Method D 92. Test Method D 1310 can be employed if the flash point is below 79°C (175°F); as determined by Test Method D 92 – IP 36.

1.3 *This standard should be used to measure and describe the properties of materials, products, or assemblies in response to heat and flame under controlled laboratory conditions and should not be used to describe or appraise the fire hazard or fire risk of materials, products, or assemblies under actual fire conditions. However, results of this test may be used as elements of a fire risk assessment which takes into account all of the factors which are pertinent to an assessment of the fire hazard of a particular end use.*

1.4 *This standard does not purport to address all of the safety problems associated with its use. It is the responsibility*

*of the user of this standard to establish appropriate safety and health practices and determine the applicability of regulatory limitations prior to use. See Section 7 and Notes 5 and 6.*

#### 2. Referenced Documents

##### 2.1 ASTM Standards:

- D 93 Test Methods for Flash Point by Pensky-Martens Closed Tester<sup>2</sup>
- D 140 Practice for Sampling Bituminous Materials<sup>3</sup>
- D 1310 Test Method for Flash Point and Fire Point of Liquids by Tag Open-Cup Apparatus<sup>4</sup>
- D 4057 Practice for Manual Sampling of Petroleum and Petroleum Products<sup>5</sup>
- D 4206 Test Method for Sustained Burning of Liquid Mixtures by the Setaflash Apparatus (OpenCup)<sup>6</sup>
- E 1 Specification for ASTM Thermometers<sup>7</sup>
- E 300 Practice for Sampling Industrial Chemicals<sup>8</sup>

##### 2.2 Other Method:

- IP Method 35 Flash Point (Open) and Fire Point by Means of the Pensky-Martens Apparatus<sup>9</sup>

#### 3. Terminology

##### 3.1 Descriptions of Terms Specific to This Standard:

3.1.1 *flash*—point the lowest temperature corrected to a barometric pressure of 101.3 kPa (760 mm Hg), at which

<sup>1</sup> This test method is under the jurisdiction of ASTM Committee D-2 on Petroleum Products and Lubricants and is the direct responsibility of Subcommittee D02.08 on Volatility.

Current edition approved Oct. 26, 1990. Published December 1990. Originally published as D 92 – 21. Last previous edition D 92 – 85.

In the IP, this test method is under the jurisdiction of the Standardization Committee.

<sup>2</sup> *Annual Book of ASTM Standards*, Vols 04.09, 05.01, 06.01 and 06.03.

<sup>3</sup> *Annual Book of ASTM Standards*, Vols 04.03, 04.04 and 04.08.

<sup>4</sup> *Annual Book of ASTM Standards*, Vols 05.01, 06.01, and 06.03.

<sup>5</sup> *Annual Book of ASTM Standards*, Vol 05.03.

<sup>6</sup> *Annual Book of ASTM Standards*, Vol 06.03.

<sup>7</sup> *Annual Book of ASTM Standards*, Vols 05.03 and 14.03.

<sup>8</sup> *Annual Book of ASTM Standards*, Vols 06.03 and 15.05.

<sup>9</sup> Available from the Institute of Petroleum, 61 New Cavendish Street, London, W.1., England.



trated in Figs. 1, 2, and 3, respectively. Dimensions are listed in Tables 1, 2, and 3, respectively.

6.2 *Shield*—A shield 460 mm (18 in.) square and 610 mm (24 in.) high and having an open front is recommended.

6.3 *Thermometer*—A thermometer having a range as shown below and conforming to the requirements prescribed in Specification E 1 or in the Specifications for IP Standard Thermometers:

Temperature Range	Thermometer Number	
	ASTM	IP
-6 to +400°C	11C	28C
20 to 760°F	11F	28F

NOTE 2—There are automatic flash point testers available and in use that can be advantageous in the saving of testing time, and in other ways that can justify their use. In any cases of dispute, the flash point as determined manually is available as the referee.

### 7. Safety Precautions

7.1 The operator must exercise and take appropriate safety precautions during the initial application of the test flame, since samples containing low-flash material may give an abnormally strong flash when the test flame is first applied.

### 8. Sampling

8.1 Proper sampling procedures must be followed. If samples are not properly obtained, erroneous flash point will result.

8.2 The following sampling standards are applicable: Practices D 140, D 4057, and E 300.

8.3 Do not store samples in plastic (polyethylene, polypropylene, etc.) containers since volatile material can diffuse through the walls of the container.

8.4 Do not use samples from leaky containers.

8.5 Light hydrocarbons can be present in the form of gases, such as propane or butane and not be detected by testing because of losses during sampling and loading of the test apparatus. This is especially evident on heavy residuums

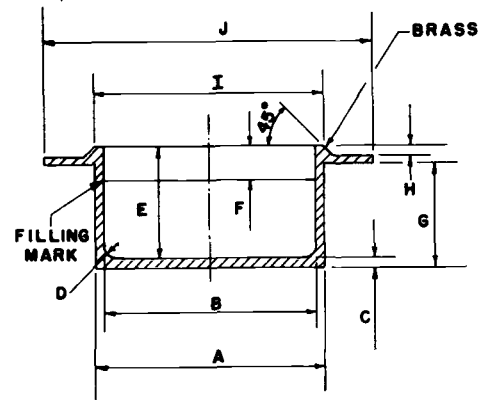

	millimetres		inches	
	min	max	min	max
A	67.5	69	2.658	2.717
B	63	64	2.480	2.520
C	2.8	3.5	0.110	0.138
D—Radius	4	nominal	0.157	nominal
E	32.5	34	1.280	1.339
F	9	10	0.354	0.394
G	31	32.5	1.221	1.280
H	2.8	3.5	0.110	0.138
I	67	70	2.638	2.756
J	97	100	3.819	3.937

FIG. 3 Cleveland Open Cup

or asphalts from solvent extraction processes.

8.6 Air bubbles or foam collected on the surface of the specimen must be eliminated or erroneous flash point will result that cannot be reported.

8.7 Solid samples shall not be added to the cup. Solid or viscous samples should be heated until they are fluid before being poured into the cup; however, the temperature during heating must not exceed 56°C (100°F) below the probable flash point.

### 9. Preparation of Apparatus

9.1 Support the apparatus on a level steady table in a draft-free room or compartment. Shield the top of the apparatus from strong light by any suitable means to permit ready detection of the flash point. Tests made in a laboratory hood (Note 3) or in any location where drafts occur are not to be relied upon. During the last 17°C (30°F) rise in temperature prior to the flash point, care must be taken to avoid disturbing the vapors in the test cup by careless movements or breathing near the cup.

NOTE 3—With some samples whose vapors or products of pyrolysis are objectionable, it is permissible to place the apparatus with shield in a hood, the draft of which is adjustable so that vapors may be withdrawn without causing air currents over the test cup during the final 100°F (56°C) rise in temperature prior to the flash point.

9.2 Wash the test cup with an appropriate solvent to remove any oil or traces of gum or residue remaining from a previous test. If any deposits of carbon are present, they should be removed with steel wool. Flush the cup with cold water and dry for a few minutes over an open flame or a hot plate to remove the last traces of solvent and water. Cool the cup to at least 56°C (100°F) below the expected flash point before using.

9.3 Support the thermometer in a vertical position with

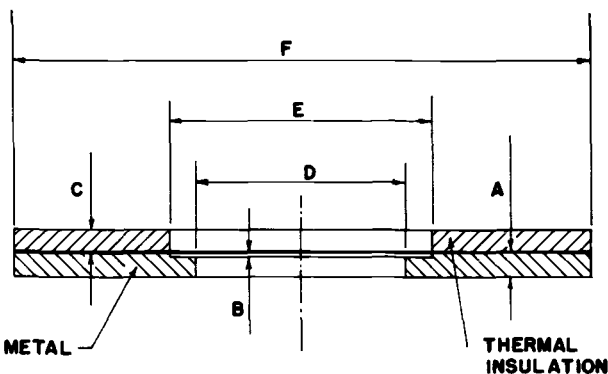

	millimetres		inches	
	min	max	min	max
A	6	7	0.26	0.276
B	0.5	1.0	0.020	0.039
C	6	7	0.236	2.276
D—Diameter	55	56	2.165	2.205
E—Diameter	69.5	70.5	2.736	2.776
F—Diameter	146	159	5.748	6.260

FIG. 2 Heating Plate

the bottom of the bulb ¼ in. (6.4 mm) from the bottom of the cup and locate at a point halfway between the center and side of the cup on a diameter perpendicular to the arc (or line) of the sweep of the test flame and on the side opposite to the test flame burner arm.

NOTE 4—The immersion line engraved on the thermometer will be 2 mm (3/64 in.) below the level of the rim of the cup when the thermometer is properly positioned.

### 10. Procedure

10.1 Fill the cup at any convenient temperature so that the top of the meniscus is exactly at the filling line. If too much sample has been added to the cup, remove the excess, using a medicine dropper; however, if there is sample on the outside of the apparatus, empty, clean, and refill it. Destroy or remove any air bubbles or foam on the surface of the liquid while maintaining proper level of the liquid in the cup. If a foam persists prior to the final test, discard the tests as the results are erroneous. Viscous samples should be heated until they are reasonably fluid before being poured into the cup; however, the temperature during heating must not exceed 56°C (100°F) below the probable flash point.

10.2 Light the test flame and adjust it to a diameter of 3.2 to 4.8 mm (1/8 to 3/16 in.), the size of the comparison bead if one is mounted on the apparatus.

10.3 Apply heat initially so that the rate of temperature rise of the sample is 14 to 17°C (25 to 30°F)/min. When the sample temperature is approximately 56°C (100°F) below the anticipated flash point, decrease the heat so that the rate of temperature rise of the last 28°C (50°F) before the flash point is 5 to 6°C (9 to 11°F)/min.

10.4 Starting at least 28°C (50°F) below the flash point, apply the test flame when the temperature read on the thermometer reaches each successive 2°C (5°F) mark. Pass the test flame across the center of the cup, at right angles to the diameter which passes through the thermometer. With a smooth, continuous motion apply the flame either in a straight line or along the circumference of a circle having a radius of at least 150 mm (6 in.). The center of the test flame must move in a horizontal plane not more than 2 mm (5/64 in.) above the plane of the upper edge of the cup and passing in one direction only. At the time of the next test flame application, pass the flame in the opposite direction. The time consumed in passing the test flame across the cup in each case shall be about 1 s.

NOTE 5: **Caution**—Meticulous attention to all details relating to the test flame applicator, size of the test flame, rate of temperature increase, and rate of passing the test flame over the sample are desirable for good results.

10.5 Record as the observed flash point the temperature read on the thermometer when a flash appears at any point on the surface of the oil, but do not confuse the true flash with the bluish halo that sometimes surrounds the test flame.

10.6 To determine the fire point, continue heating so that the sample temperature increases at a rate of 5 to 6°C (9 to 11°F)/min. Continue the application of the test flame at 2°C (5°F) intervals until the oil ignites and continues to burn for

at least 5 s. Record the temperature at this point as the observed fire point of the oil.

### 11. Calculation and Report

11.1 Observe and record the barometric pressure at the time of the test. When the pressure differs from 101.3 kPa (760 mm Hg), correct the flash or fire point, or both, by means of the following equations:

$$\text{Corrected flash or fire point} = C + 0.25 (101.3 - p) \quad (1)$$

$$\text{Corrected flash or fire point} = F + 0.06 (760 - P) \quad (2)$$

$$\text{Corrected flash or fire point} = C + 0.033 (760 - P) \quad (3)$$

where:

$C$  = observed flash or fire point, °C,

$F$  = observed flash or fire point, °F,

$p$  = ambient barometric pressure, kPa, and

$P$  = ambient barometric pressure, mm Hg

11.2 The corrected values should be used as determined in the correction equation. Values should then be rounded off to the nearest 2°C (5°F) when reported.

NOTE 6: **Caution**—The barometric pressure used in this calculation is the ambient pressure for the laboratory at the time of test. Many aneroid barometers, such as those used at weather stations and airports, are precorrected to give sea level readings. These, if used, would give erroneous results.

### 12. Precision and Bias

12.1 *Precision*—The precision of this test method as determined by the statistical examination of the interlaboratory test results is as follows:

12.1.1 *Repeatability*—The difference between successive results obtained by the same operator with the same apparatus under constant operating conditions on identical test materials would, in the long run, in the normal and correct operation of the test method exceed the following values only in one case in twenty:

	Repeatability
Flash point	8°C (15°F)
Fire point	8°C (15°C)

12.1.2 *Reproducibility*—The difference between two single and independent results obtained by different operators working in different laboratories on identical material would in the long run, exceed the following values only in one case in twenty:

	Reproducibility
Flash point	17°C (30°F)
Fire point	14°C (25°F)

12.1.3 The precision data is not known to have been developed in accordance with Research Report D-2-1007.

12.2 *Bias*—The procedure in this test method has no bias because flash or fire point can be defined only in terms of a test method.

### 13. Keywords

13.1 Cleveland open cup; flash point; fire point, open cup for flash point

## ANNEX

## (Mandatory Information)

## A1. APPARATUS FOR THE CLEVELAND OPEN TESTER

A1.1 *Test Cup*, conforming to and with dimensions as shown in Fig. 3. The cup shall be made of brass or other non-rusting metal of equivalent heat conductivity. The cup may be equipped with a handle.

A1.2 *Heating Plate*—A brass, cast iron, wrought iron, or steel plate with a center hole surrounded by an area of plane depression, and a sheet of compressed insulating sheet, non-asbestos<sup>10</sup> which covers the metal plate except over the area of plane depression in which the test cup is supported. The essential dimensions of the heating plate are shown in Fig. 2; however, it may be square instead of round, and the metal plate may have suitable extensions for mounting the test flame applicator device and the thermometer support. Also, a metal bead, as mentioned in A1.3, can be mounted on the plate so that it extends through and slightly above a suitable small hole in the compressed insulating sheet.

A1.3 *Test Flame Applicator*—The device for applying the flame can be of any suitable type, but it is suggested that the tip be approximately 1.6 mm ( $1/16$  in.) in diameter at the end, and that the orifice be 0.8 mm ( $1/32$  in.) in diameter. The device for operating the test flame can be mounted in such a

manner as to permit automatic duplication of the sweep of the test flame, the radius of swing being not less than 150 mm (6 in.) and the center of the orifice being supported so that it swings in a plane not greater than 2 mm ( $5/64$  in.) above the plane of the rim of the cup. It is desired that a bead, having a diameter of 3.2 to 4.8 mm ( $1/8$  to  $3/16$  in.) be mounted in a convenient position on the apparatus so that the size of the test flame can be compared to it.

A1.4 *Heater*—Heat may be supplied from any convenient source. The use of a gas burner or alcohol lamp is permitted, but under no circumstances are products of combustion or free flame to be allowed to come up around the cup. An electric heater controlled by a variable voltage transformer is preferred. The source of heat shall be centered under the opening of the heating plate with no local superheating. Flame-type heaters can be protected from drafts or excessive radiation by any suitable type of shield that does not project above the level of the upper surface of the asbestos board.

A1.5 *Thermometer Support*—Any convenient device can be used which will hold the thermometer in the specified position during a test and which will permit easy removal of the thermometer from the test cup upon completion of a test.

A1.6 *Heating Plate Support*—Any convenient support which will hold the heating plate level and steady can be employed.

<sup>10</sup> Available from John Crane, Inc., 6400 Oakton Street, Morton Grove, IL 60053; Richard Klinger, Inc., 2350 Campbell Road, Sidney, OH 45365, and others.

*The American Society for Testing and Materials takes no position respecting the validity of any patent rights asserted in connection with any item mentioned in this standard. Users of this standard are expressly advised that determination of the validity of any such patent rights, and the risk of infringement of such rights, are entirely their own responsibility.*

*This standard is subject to revision at any time by the responsible technical committee and must be reviewed every five years and if not revised, either reapproved or withdrawn. Your comments are invited either for revision of this standard or for additional standards and should be addressed to ASTM Headquarters. Your comments will receive careful consideration at a meeting of the responsible technical committee, which you may attend. If you feel that your comments have not received a fair hearing you should make your views known to the ASTM Committee on Standards, 1916 Race St., Philadelphia, PA 19103.*



Designation: D 93 – 90



Designation: 34/85

An American National Standard  
British Standard 2839  
American Association State  
Highway Transportation Standard  
AASHTO No. T73 – 811

## Standard Test Methods for Flash Point by Pensky-Martens Closed Tester<sup>1</sup>

This standard is issued under the fixed designation D 93; the number immediately following the designation indicates the year of original adoption or, in the case of revision, the year of last revision. A number in parentheses indicates the year of last reapproval. A superscript epsilon ( $\epsilon$ ) indicates an editorial change since the last revision or reapproval.

*These test methods were adopted as a joint ASTM-IP Standard in 1967.*

*These test methods have been adopted for use by government agencies to replace Method 1102 of Federal Test Method Standard No. 791b, and Method 4293 of Federal Test Method Standard No. 141A.*

### INTRODUCTION

This flash point test method depends on definite rates of temperature increases to control the precision of the method. It is considered to be a non-equilibrium method. The rate of heating will not give the precision expected in all cases because of the low thermal conductivity of some materials. To reduce this effect, Test Method D 3941 was issued in which the heating rate is considered to be an equilibrium method. Due to the slower heating rate, the time required to make a determination is considerably longer. If your specification requires Test Method D 93, do not substitute Test Method D 3941 or any other method without obtaining comparative data and agreement from the specifier.

#### 1. Scope

1.1 These test methods cover the determination of the flash point by Pensky-Martens closed-cup tester of fuel oils, lube oils, suspensions of solids, liquids that tend to form a surface film under test conditions, and other liquids of similar viscosities.

NOTE 1—This test method can be employed for the detection of contamination of lubricating oils by minor amounts of volatile materials.

NOTE 2—The U.S. Department of Transportation (DOT)<sup>2</sup> and U.S. Department of Labor (OSHA) have established that liquids with a flash point under 100°F (37.8°C) are flammable as determined by methods for those liquids which have a viscosity of 5.8 cSt or more at 100°F (37.8°C) or 9.5 cSt or more at 77°F (25°C), or that contain suspended solids, or have a tendency to form a surface film while under test. Other classification flash points have been established by these departments for liquids using this test. These regulations are in degrees Fahrenheit.

1.2 Liquids having viscosities less than 5.5 cSt at 40°C (104°F) do not contain suspended solids or do not have a tendency to form a surface film while under test conditions can be tested in accordance with Test Method D 56.

1.3 The values stated in SI units shall be regarded as the

standard. The values given in parentheses are for information only.

1.4 *This standard should be used to measure and describe the properties of materials, products, or assemblies in response to heat and flame under controlled laboratory conditions and should not be used to describe or appraise the fire hazard or fire risk of materials, products, or assemblies under actual fire conditions. However, results of this test may be used as elements of a fire risk assessment which takes into account all of the factors which are pertinent to an assessment of the fire hazard of a particular end use.*

1.5 *This standard does not purport to address all of the safety problems associated with its use. It is the responsibility of the user of this standard to establish appropriate safety and health practices and determine the applicability of regulatory limitations prior to use. For specific hazards statements, see Section 7 and Note 5.*

#### 2. Referenced Documents

##### 2.1 ASTM Standards:

- D 56 Test Method for Flash Point by Tag Closed Tester<sup>3</sup>
- D 850 Test Method for Distillation of Industrial Aromatic Hydrocarbons and Related Materials<sup>4</sup>
- D 1015 Test Method for Freezing Point of High-Purity Hydrocarbons<sup>3</sup>
- D 1016 Test Method for Purity of Hydrocarbons from Freezing Points<sup>3</sup>
- D 1078 Test Method for Distillation Range of Volatile Organic Liquids<sup>4</sup>

<sup>1</sup> These test methods are under the jurisdiction of ASTM Committee D-2 on Petroleum Products and Lubricants and are the direct responsibility of Subcommittee D02.08 on Volatility.

In the IP, these methods are under the jurisdiction of the Standardization Committee.

Current edition approved Oct. 26, 1990. Published December 1990. Originally published as D 93 – 21 T. Last previous edition D 93 – 85.

<sup>2</sup> For information concerning regulations of U.S. Department of Transportation, see Codes of U.S. Regulations 49 CFR, Chapter I, and of U.S. Department of Labor, see 29 CFR, Chapter XVII. Each of these items is revised annually and may be procured from Superintendent of Documents, Government Printing Office, Washington, DC 20402.

<sup>3</sup> *Annual Book of ASTM Standards*, Vols 05.01 and 06.03.

<sup>4</sup> *Annual Book of ASTM Standards*, Vol 06.03.

- D 3941 Test Method for Flash Point by the Equilibrium Method With a Closed Cup Apparatus<sup>4</sup>
- D 4057 Practice for Manual Sampling of Petroleum and Petroleum Products<sup>5</sup>
- E 1 Specification for ASTM Thermometers<sup>6</sup>
- E 300 Practice for Sampling Industrial Chemicals<sup>7</sup>

### 3. Terminology

#### 3.1 Description of a Term Specific to This Standard:

3.1.1 *flash point*—the lowest temperature corrected to a barometric pressure of 101.3 kPa (760 mm Hg), at which application of a test flame causes the vapor of a specimen to ignite under specified conditions of test.

3.1.1.1 *Discussion*—The sample is deemed to have flashed when a large flame appears and instantaneously propagates itself over the surface of the sample.

3.1.1.2 *Discussion*—Occasionally, the application of the test flame will cause a blue halo or an enlarged flame. This generally occurs near the actual flash point but in some cases, especially with halogenated hydrocarbons and admixtures, can occur at any temperature. These phenomena are not to be considered true flash points.

### 4. Summary of Test Methods

4.1 The sample is heated at a slow, constant rate with continual stirring. A small flame is directed into the cup at regular intervals with simultaneous interruption of stirring. The flash point is the lowest temperature at which application of the test flame causes the vapor above the sample to ignite.

### 5. Significance and Use

5.1 Flash point measures tendency of the sample to form a flammable mixture with air under controlled laboratory conditions. It is only one of a number of properties which must be considered in assessing the overall flammability hazard of a material.

5.2 Flash point is used in shipping and safety regulations to define flammable and combustible materials. One should consult the particular regulation involved for precise definitions of these classes.

5.3 Flash point can indicate the possible presence of highly volatile and flammable materials in a relatively nonvolatile or nonflammable material. For example, an abnormally low flash point on a sample of kerosine can indicate gasoline contamination.

5.4 This test method provides the only closed cup flash point test procedures for temperatures to 370°C (698°F).

### 6. Apparatus

6.1 *Pensky-Martens Closed Flash Tester*, as described in Annex A1.

6.2 *Thermometers*—Three standard thermometers shall be used with the ASTM Pensky-Martens tester as follows:

6.2.1 For tests in which the indicated reading falls within the limits of 10 to 60°C (50 to 140°F), inclusive, an ASTM 9C (9F) Pensky-Martens low range Thermometer having a

range from -5 to +110°C (20 to 230°F) and conforming to the requirements of Specification E 1 shall be used. Equally acceptable is IP thermometer 15C (15F), with specifications as shown in Annexes A2 and A3.

6.2.2 For tests in which the indicated reading falls within the limits 60 to 140°C (140 to 284°F), inclusive, an ASTM 88C (88F) Vegetable Oil Flash Thermometer having a range of 10 to 200°C (50 to 392°F) and conforming to the requirements of Specification E 1 shall be used. Equally acceptable is IP thermometer IP 101C.

6.2.3 For the range 60 to 110°C (140 to 230°F) either low or medium range thermometer may be used.

6.2.4 For tests in which the indicated reading falls within 130 to 370°C (265 to 700°F) an ASTM 10C (10F) Pensky-Martens high-range Thermometer having a range from 90 to 370°C (200 to 700°F) and conforming to the requirements of Specification E 1 shall be used. Equally acceptable is IP thermometer 16C (16F), with specifications as shown in Annex A3.

6.2.5 For the range 130 to 140°C (265 to 285°F) either the medium or high-range thermometer may be used.

NOTE 3—There are automatic flash point testers available and in use that may be advantageous in that they save testing time and exhibit other factors which may merit their use. In any cases of dispute the flash point as determined manually is considered the referee test.

### 7. Hazards

7.1 The operator must exercise and take appropriate safety precautions during the initial application of the test flame, since samples containing low-flash material can give an abnormally strong flash when the test flame is first applied.

### 8. Sampling

8.1 Erroneously high flash points may be obtained if precautions are not taken to avoid the loss of volatile material. Do not open containers unnecessarily and make a transfer unless the sample temperature is at least the equivalent of 8°C (18°F) below the expected flash point. Do not use samples from leaky containers for these test methods.

8.2 Do not store samples in plastic (polyethylene, polypropylene, etc.) containers, since volatile material may diffuse through the walls of the enclosure.

8.3 Obtain a sample in accordance with instructions given in Practice D 4057 or E 300.

8.4 Samples of very viscous materials may be warmed until they are reasonably fluid before they are tested. However, no sample should be heated more than is absolutely necessary. It shall never be heated above a temperature of 17°C (30°F) below its expected flash point.

8.5 Samples containing dissolved or free water may be dehydrated with calcium chloride or by filtering through a qualitative filter paper or a loose plug of dry absorbent cotton. Warming the sample is permitted, but it should not be heated for prolonged periods or above a temperature of 17°C (30°F) below its expected flash point.

NOTE 4—If the sample is suspected of containing volatile contaminants, the treatment described in 8.4 and 8.5 should be omitted.

### 9. Preparation of Apparatus

9.1 Support the tester on a level, steady table. Unless tests

<sup>5</sup> Annual Book of ASTM Standards, Vol 05.03.

<sup>6</sup> Annual Book of ASTM Standards, Vols 05.03 and 14.03.

<sup>7</sup> Annual Book of ASTM Standards, Vols 06.03 and 15.05.

are made in a draft-free room or compartment, it is good practice, but not required, to surround the tester on three sides with a shield, each section of which is about 450 mm (18 in.) wide and 600 mm (24 in.) high.

**NOTE 5—Caution**—Meticulous attention to all details relating to the flame exposure device, size of test flame, rate of temperature increase, and rate of dipping the flame exposure device into the vapor of the specimen is desirable for good results.

## 10. Calibration

10.1 Determine the flash point of *p*-xylene<sup>8</sup> (**Warning**—See Note 6.), following the directions in Sections 9 through 11. When the tester is operating properly, a value of  $27.2 \pm 1.1^\circ\text{C}$  ( $81 \pm 2^\circ\text{F}$ ) will be obtained.

**NOTE 6: Warning**—*P*-xylene is extremely flammable. Harmful if inhaled. Keep away from heat, sparks and open flame. Keep container closed. Use with adequate ventilation. Avoid buildup of vapors and eliminate all sources of ignition, especially non-explosion proof electrical apparatus and heaters. Avoid breathing vapor or spray mist. Avoid prolonged or repeated contact with skin.

10.2 If the flash point obtained on *p*-xylene is not within the limits stated in 14.1.2, check the condition and operation of the apparatus to ensure conformity with the details listed in Annex A1, especially with regard to the tightness of the lid (A1.1.2.1), the action of the shutter, and position of the test flame (A1.1.2.2). After adjustment, if necessary, repeat the test. *P*-xylene having a flash point of  $27.2 \pm 1.1^\circ\text{C}$  ( $81 \pm 2^\circ\text{F}$ ) is not a suitable reference in the high temperature range of the Pensky-Martens Closed Tester which can be as high as  $370^\circ\text{C}$  ( $700^\circ\text{F}$ ).

10.3 *P*-xylene shall conform to the following requirements:

Specific Gravity	15.56/15.56°C 0.860 min., 0.866 max.
Boiling Range	2°C from start to dry, point when tested in accordance with Test Method D 850 or D 1078. The range shall include the boiling point of pure <i>p</i> -xylene which is $138.35^\circ\text{C}$ ( $281.03^\circ\text{F}$ ).
Purity	95 % min., (freezing point of $11.23^\circ\text{C}$ ), min calculated in accordance with Test Method D 1016, from the experimentally determined freezing point, measured by Test Method D 1015.

## PROCEDURE A—DETERMINATION OF FLASH POINT OF ORDINARY LIQUIDS

### 11. Procedure

11.1 Thoroughly clean and dry all parts of the cup and its accessories before starting the test, being sure to remove any solvent which had been used to clean the apparatus. Fill the cup with the sample to be tested to the level indicated by the filling mark. Place the lid on the cup and set the latter in the stove. Be sure to have the locating or locking device properly engaged. Insert the thermometer. Bring the material to be tested and the tester to a temperature of  $15 \pm 5^\circ\text{C}$  ( $60 \pm 10^\circ\text{F}$ ) or  $11^\circ\text{C}$  ( $20^\circ\text{F}$ ) lower than the estimated flash point, whichever is lower. Light the test flame and adjust it to 4 mm ( $\frac{5}{32}$  in.) in diameter. Supply the heat at such a rate that the temperature as indicated by the thermometer increases 5 to

$6^\circ\text{C}$  ( $9$  to  $11^\circ\text{F}$ )/min. Turn the stirrer 90 to 120 rpm, stirring in a downward direction.

11.2 If the sample is known to have a flash point of  $110^\circ\text{C}$  ( $230^\circ\text{F}$ ) or below, apply the test flame when the temperature of the sample is from  $17^\circ\text{C}$  ( $30^\circ\text{F}$ ) to  $28^\circ\text{C}$  ( $50^\circ\text{F}$ ) below the expected flash point and thereafter at a temperature reading that is a multiple of  $1^\circ\text{C}$  ( $2^\circ\text{F}$ ). Apply the test flame by operating the mechanism on the cover which controls the shutter and test flame burner so that the flame is lowered into the vapor space of the cup in 0.5 s, left in its lowered position for 1 s, and quickly raised to its high position. Do not stir the sample while applying the test flame.

11.3 If the sample is known to have a flash point above  $110^\circ\text{C}$  ( $230^\circ\text{F}$ ) apply the test flame in the manner just described at each temperature that is a multiple of  $2^\circ\text{C}$  ( $5^\circ\text{F}$ ), beginning at a temperature of  $17^\circ\text{C}$  ( $30^\circ\text{F}$ ) to  $28^\circ\text{C}$  ( $50^\circ\text{F}$ ) below the expected flash point.

**NOTE 7**—When testing materials to determine if volatile contaminants are present, it is not necessary to adhere to the temperature limits for initial flame application as stated in 11.2 and 11.3.

11.4 Record as the observed flash point the temperature read on the thermometer at the time the test flame application causes a distinct flash in the interior of the cup. Do not confuse the true flash point with the bluish halo that sometimes surrounds the test flame at applications preceding the one that causes the actual flash.

## PROCEDURE B—DETERMINATION OF FLASH POINT OF SUSPENSIONS OF SOLIDS AND HIGHLY VISCOUS MATERIALS

### 12. Procedure

12.1 Bring the material to be tested and the tester to a temperature of  $15 \pm 5^\circ\text{C}$  ( $60 \pm 10^\circ\text{F}$ ) or  $11^\circ\text{C}$  ( $20^\circ\text{F}$ ) lower than the estimated flash point, whichever is lower. Turn the stirrer  $250 \pm 10$  rpm, stirring in a downward direction. Raise the temperature throughout the duration of the test at a rate of not less than 1 nor more than  $1.5^\circ\text{C}$  ( $2$  to  $3^\circ\text{F}$ )/min. With the exception of these requirements for rates of stirring and heating, proceed as prescribed in Section 11.

### 13. Calculation and Report

13.1 Observe and record the ambient barometric pressure (Note 7) at the time of the test. When the pressure differs from 101.3 kPa (760 mm Hg), correct the flash point as follows:

$$\text{Corrected flash point} = C + 0.25 (101.3 - p) \quad (1)$$

$$\text{Corrected flash point} = F + 0.06 (760 - P) \quad (2)$$

$$\text{Corrected flash point} = C + 0.033 (760 - P) \quad (3)$$

where:

*C* = observed flash point, °C,

*F* = observed flash points, °F,

*P* = ambient barometric pressure, mm Hg, and

*p* = ambient barometric pressure, kPa.

13.2 Record the corrected flash point to the nearest  $0.5^\circ\text{C}$  (or  $1^\circ\text{F}$ ).

13.3 Report the recorded flash point as the Pensky-Martens Closed Cup Flash Point ASTM D 93 – IP 34, of the sample tested.

**NOTE 8**—The barometric pressure used in this calculation is the ambient pressure for the laboratory at the time of test. Many aneroid

<sup>8</sup> Satisfactory *p*-xylene may be obtained as Flash Point Check Fluid from the Special Products Div., Chemical Dept., Phillips Petroleum Co., Drawer O, Borger, TX 79007.



barometers, such as those used at weather stations and airports, are precorrected to give sea level readings and would not give the correct reading for this test.

**14. Precision and Bias**

14.1 *Precision*—The precision of Test Procedure A as determined by the statistical examination of the interlaboratory test results is as follows:

14.1.1 *Repeatability*—The difference between successive results obtained by the same operator with the same apparatus under constant operating conditions on identical test materials would, in the long run, in the normal and correct operation of the test method, exceed the following values in 1 case in 20.

Material	Flash Point Range °C (°F)	Repeatability °C (°F)
Suspensions of solids	35 to 43 (95 to 110)	2 (4)
All others	104 (220) and under	2 (4)
	Above 104 (220)	5.5 (10)

14.1.2 *Reproducibility*—The difference between two single and independent results obtained by different operators working in different laboratories on identical material would, in the long run, exceed the following values only in 1 case in 20.

Material	Flash Point Range °C (°F)	Reproducibility °C (°F)
Suspensions of solids	35 to 43 (95 to 110)	3.5 (6)
All others	104 (220) and under	3.5 (6)
	Above 104 (220)	8.5 (15)

14.1.3 *Bias*—The procedure of this test method has no bias because flash point can be defined only in terms of a test method.

14.1.4 The precision data is not known to have been

developed in accordance with Research Report D-2-1007.

14.2 *Precision*—The precision of Test Procedure B as determined by the statistical examination of the interlaboratory test results is as follows:

14.2.1 *Repeatability*—The difference between successive results obtained by the same operator with the same apparatus under constant operating conditions on identical test materials would, in the long run, in the normal and correct operation of the test method, exceed the following value in 1 case in 20:

Repeatability 5°C (9°F)

14.2.2 *Reproducibility*—The difference between 2 single and independent results obtained by different operators working in different laboratories on identical material would, in the long run, exceed the following value only in 1 case in 20.

Reproducibility 10°C (18°F)

14.2.3 The procedure of this test method has no bias because flash point can be defined only in terms of a test method.

14.2.4 The precision data is not known to have been developed in accordance with Research Report D-2-1007.

14.3 The definition of repeatability and reproducibility given here represents different components of the variance of the test methods: those given in 14.1 are derived from standards of ASTM Committee D-2 and the Institute of Petroleum, while those of 14.2 are from ASTM Committee D-2.

**15. Keywords**

15.1 flash point; Pensky-Martens closed cup; flash point; flammability

ANNEXES

(Mandatory Information)

A1. APPARATUS SPECIFICATIONS

A1.1 A typical assembly of the apparatus, gas heated, is shown in Fig. A1.1. The apparatus shall consist of a test cup, cover, and stove conforming to the following requirements:

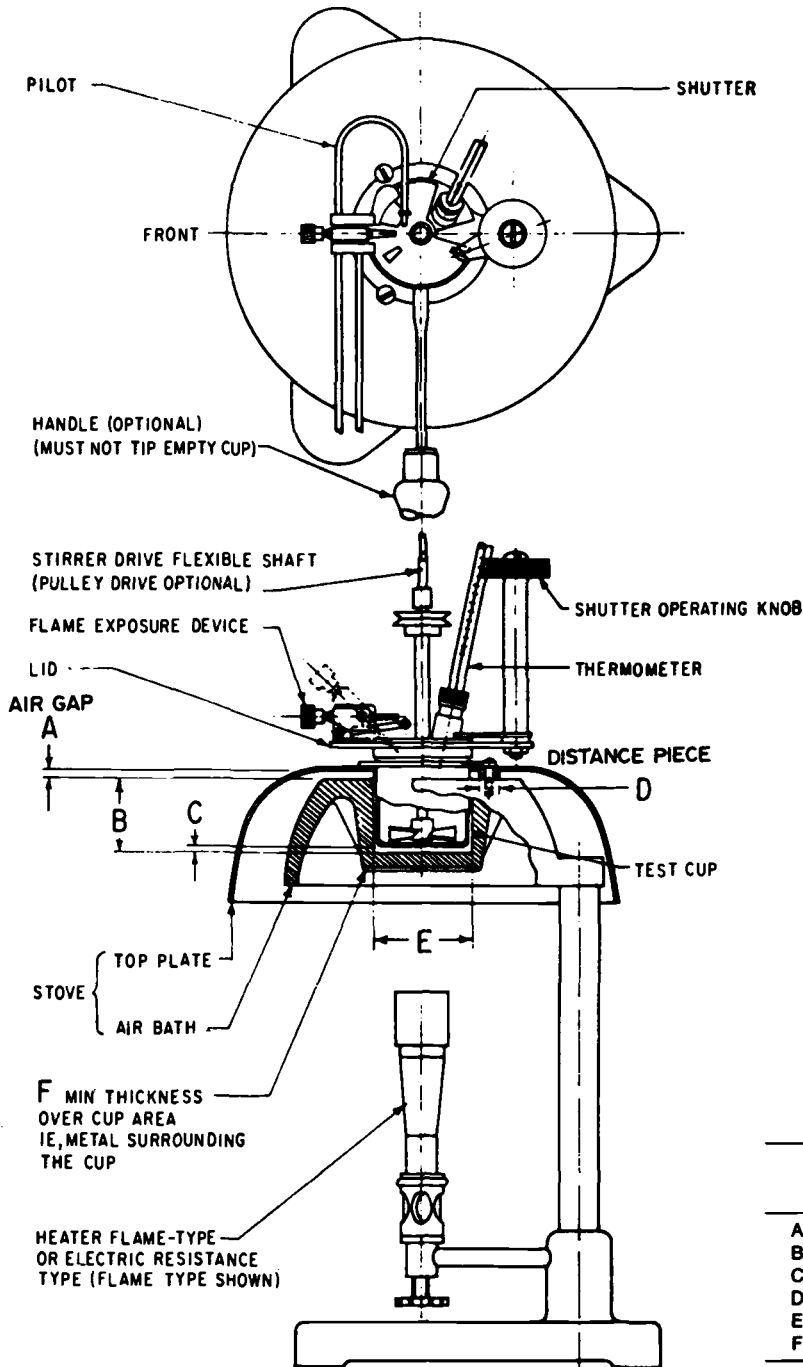

	mm		(in.)	
	min	max	(min)	(max)
A	4.37	5.16	(0.172)	(0.203)
B	41.94	42.06	(1.651)	(1.656)
C	1.58	3.18	(0.062)	(0.125)
D	...	9.52	(...)	(0.375)
E	57.23	57.86	(2.253)	(2.278)
F	6.35	...	(0.25)	(...)

NOTE—Lid assembly may be positioned either right or left-handed.

FIG. A1.1 Pensky-Martens Closed Flash Tester

A1.1.1 *Cup*—The cup shall be of brass, or other nonrusting metal of equivalent heat conductivity, and shall conform to the dimensional requirements in Fig. A1.2. The flange shall be equipped with devices for locating the position of the cup in the stove. A handle attached to the flange of the cup is a desirable accessory. The handle shall not be so heavy as to tip over the empty cup.

A1.1.2 *Cover*:

A1.1.2.1 *Cover Proper*—The cover shown in Fig. A1.3 shall be of brass (A1.1.1) and shall have a rim projecting downward almost to the flange of the cup. The rim shall fit the outside of the cup with a clearance not exceeding 0.36 mm (0.014 in.) on the diameter. There shall be a locating or locking device, or both, engaging with a corresponding device on the cup. The four openings in the cover, *A*, *B*, *C*, and *D*, are shown in Fig. A1.3. The upper edge of the cup shall be in close contact with the inner face of the cover throughout its circumference.

A1.1.2.2 *Shutter*—The cover shall be equipped with a brass (Section 3) shutter (Fig. A1.4), approximately 2.4 mm ( $\frac{3}{32}$  in.) thick, operating on the plane of the upper surface of the cover. The shutter shall be so shaped and mounted that it

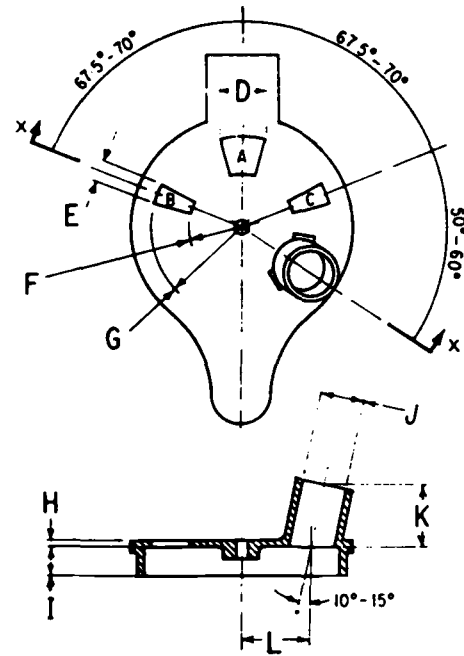

	mm		(in.)	
	min	max	(min)	(max)
D	12.7	13.5	(0.50)	(0.53)
E	4.8	5.6	(0.19)	(0.22)
F	13.5	14.3	(0.53)	(0.56)
G	23.8	24.6	(0.94)	(0.97)
H	1.2	2.0	(0.05)	(0.08)
I	7.9	...	(0.31)	(...)
J	12.27	12.32	(0.483)	(0.485)
K	16.38	16.64	(0.645)	(0.655)
L	18.65	19.45	(0.734)	(0.766)

FIG. A1.3 Cover Proper

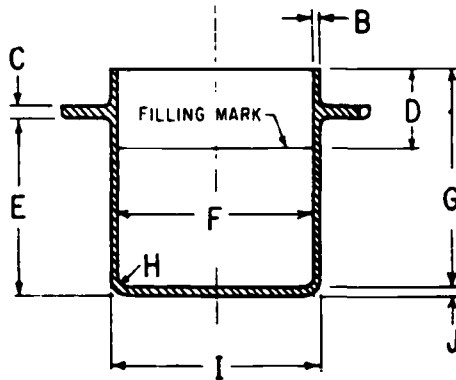
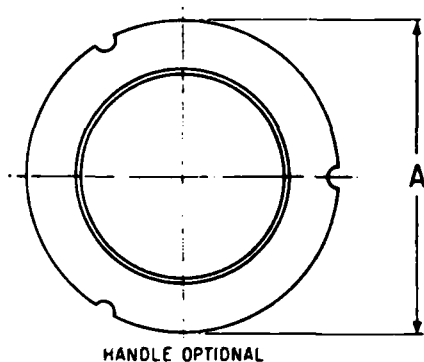

	mm		(in.)	
	min	max	(min)	(max)
A	79.0	79.8	(3.11)	(3.14)
B	1.0	...	(0.04)	(...)
C	2.8	3.6	(0.11)	(0.14)
D	21.72	21.84	(0.855)	(0.860)
E	45.47	45.72	(1.790)	(1.800)
F	50.72	50.85	(1.997)	(2.002)
G	55.75	56.00	(2.195)	(2.205)
H	3.8	4.0	(0.15)	(0.16)
I	53.90	54.02	(2.122)	(2.127)
J	2.29	2.54	(0.090)	(0.100)

FIG. A1.2 Test Cup

rotates on the axis of the horizontal center of the cover between two stops, so placed, that when in one extreme position, the openings *A*, *B*, and *C* in the cover are completely closed, and when in the other extreme position, these openings are completely opened. The mechanism operating the shutter should be of the spring type and constructed so that when at rest the shutter shall exactly close the three openings. When operated to the other extreme, the three cover openings shall be exactly open and the tip of the exposure tube shall be fully depressed.

A1.1.2.3 *Flame-Exposure Device*—The flame-exposure device (Fig. A1.4) shall have a tip with an opening 0.69 to 0.79 mm (0.027 to 0.031 in.) in diameter. This tip shall be made preferably of stainless steel, although it may be fabricated of other suitable metals. The flame-exposure device shall be equipped with an operating mechanism which, when the shutter is in the open position, depresses the tip so that the center of the orifice is between the planes of the under and upper surfaces of the cover proper at a point on a radius passing through the center of the larger opening *A* (Fig. A1.3).

A1.1.2.4 *Pilot Flame*—A pilot flame shall be provided for automatic relighting of the exposure flame. A bead 4 mm ( $\frac{5}{32}$  in.) in diameter can be mounted on the cover so that the size of the test flame can be regulated by comparison. The tip

of the pilot flame shall have an opening the same size as the tip of the flame exposure device (0.69 to 0.79 mm (0.027 to 0.031 in.) in diameter).

A1.1.2.5 *Stirring Device*—The cover shall be equipped with a stirring device (Fig. A1.4) mounted in the center of the cover and carrying two 2-bladed metal propellers. In Fig. A1.4 lower propeller is designated by the letters L, M, and N. This propeller shall measure approximately 38 mm from tip to tip, with each of its two blades 8 mm in width with a pitch of 45°. The upper propeller is designated by the letters A, C,

and G. This propeller measures approximately 19 mm, tip to tip, each of its two blades is also 8 mm in width with a pitch of 45°. Both propellers are located on the stirrer shaft in such a manner that, when viewed from the bottom of the stirrer, the blades of one propeller are at 0 and 180° while the blades of the other propeller are at 90 and 270°. A stirrer shaft may be coupled to the motor by a flexible shaft or a suitable arrangement of pulleys.

A1.1.2.6 *Stove*—Heat shall be supplied to the cup by means of a properly designed stove which is equivalent to an

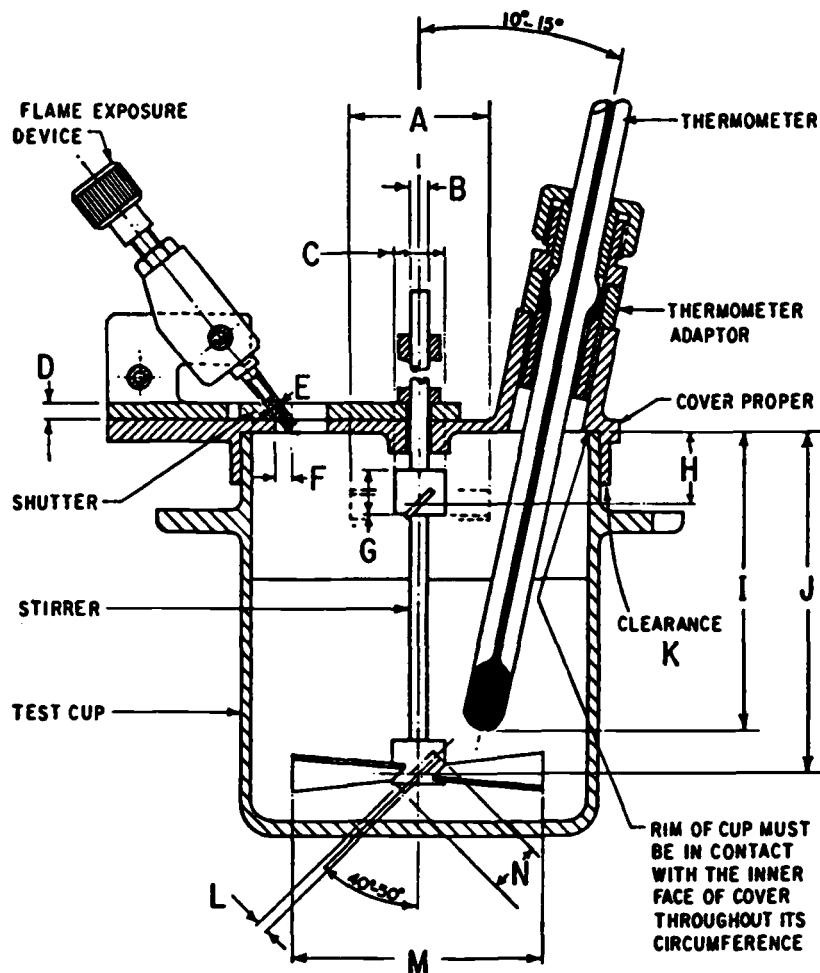

	mm		(in.)	
	min	max	(min)	(max)
A	18.3	19.8	(0.72)	(0.78)
B	2.38	3.18	(0.094)	(0.125)
C	7.6	8.4	(0.30)	(0.33)
D	2.0	2.8	(0.08)	(0.11)
E	0.69	0.79	(0.027)	(0.031)
F	2.0	2.8	(0.08)	(0.11)
G	6.4	10.4	(0.25)	(0.41)
H	9.6	11.2	(0.38)	(0.44)
I <sup>A</sup>	43.0	48.0	(1.69)	(1.81)
J	50.0	51.6	(1.97)	(2.03)
K	...	0.36	(...)	(0.014)
L	1.22	2.06	(0.048)	(0.08)
M	31.8	44.4	(1.25)	(1.75)
N	7.6	8.4	(0.30)	(0.33)

<sup>A</sup> Includes tolerance for length of thermometer given in Specification E 1.

FIG. A1.4 Test Cup and Cover Assembly

air bath. The stove shall consist of an air bath and a top plate on which the flange of the cup rests.

A1.1.2.7 *Air Bath*—The air bath shall have a cylindrical interior and shall conform to the dimensional requirements in Fig. A1.1. The air bath may be either a flame or electrically heated metal casting (A1.1.2.8), or an electric-resistance element (A1.1.2.9). In either case, the air bath must be suitable for use at the temperatures to which it will be subjected without deformation.

A1.1.2.8 *Heater, Flame or Electric*—If the heating element is a flame or an electric heater, it shall be so designed and used that the temperatures of the bottom and the walls are approximately the same. In order that the air bath internal surfaces should be at a uniform temperature, it should not be less than 6.4 mm ( $\frac{1}{4}$  in.) in thickness unless the heating element is designed to give equal heat flux densities over all the wall and bottom surfaces.

A1.1.2.9 *Heater, Electric Resistance*—If the heater is of the electric resistance type, it shall be constructed so that all parts of the interior surface are heated uniformly. The wall and bottom of the air bath shall not be less than 6.4 mm ( $\frac{1}{4}$  in.) in thickness unless the resistance heating elements are distributed over at least 80 % of the wall and all the bottom of the air bath. A heater having such a distribution of the heating elements positioned at least 4.0 mm ( $\frac{5}{32}$  in.) away from the internal surface of the heating unit can be used in conjunction with a minimum thickness of 1.58 mm ( $\frac{1}{16}$  in.) for the wall and bottom of the air bath.

A1.1.2.10 *Top Plate*—The top plate shall be of metal, and shall be mounted with an air gap between it and the air bath. It may be attached to the air bath by means of three screws and spacing bushings. The bushings should be of proper thickness to define an air gap of 4.8 mm ( $\frac{3}{16}$  in.), and they shall be not more than 9.5 mm ( $\frac{3}{8}$  in.) in diameter.

**A2. MANUFACTURING STANDARDIZATION OF THERMOMETER AND FERRULE**

A2.1 The low-range thermometer, which conforms also to the specification for the cup thermometer in the Tag closed tester (Test Method D 56) and which frequently is fitted with a metal ferrule intended to fit the collar on the cover of the Tag flash tester, can be supplemented by an adaptor (Fig. A2.1) to be used in the larger diameter collar of the

Pensky-Martens apparatus. Differences in dimensions of these collars, which do not affect test results, are a source of unnecessary trouble to manufacturers and suppliers of instruments, as well as to users.

A2.2 Dimensional requirements are shown in Fig. A2.1. Conformity to these requirements is not mandatory, but is desirable to users as well as suppliers of Pensky-Martens testers.

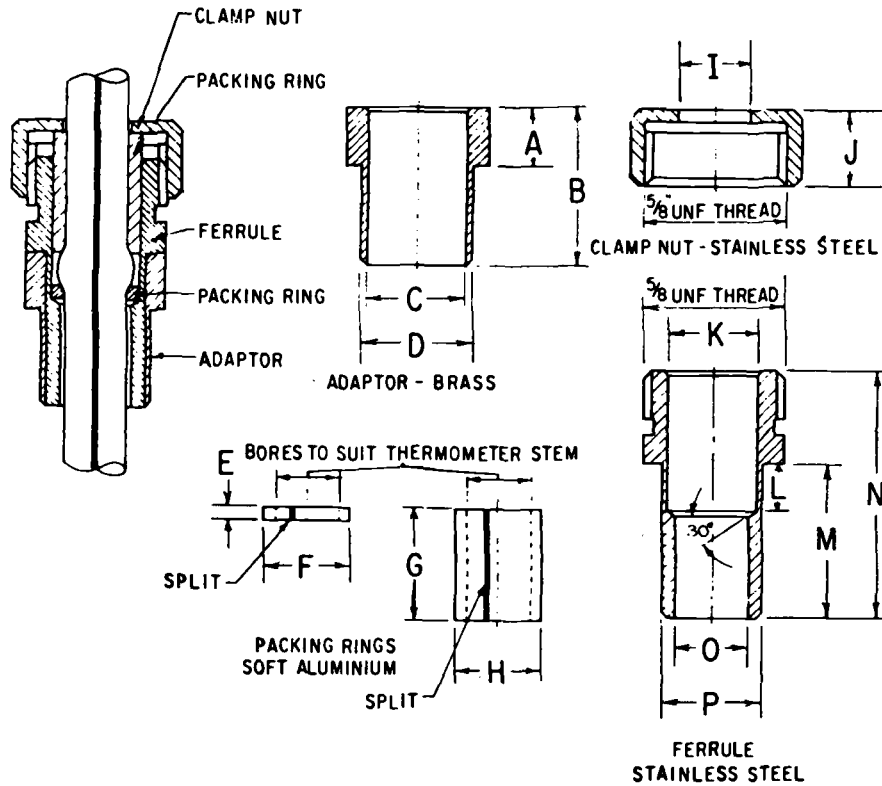

	mm		(in.)	
	min	max	(min)	(max)
A	6.20	6.50	(0.244)	(0.256)
B	17.0	18.0	(0.67)	(0.71)
C	9.80	9.85	(0.386)	(0.388)
D	12.19	12.24	(0.480)	(0.482)
E	1.40	1.65	(0.055)	(0.065)
F	8.56	8.61	(0.337)	(0.339)
G	12.4	13.0	(0.49)	(0.57)
H	8.56	8.61	(0.337)	(0.339)
I	8.1	8.6	(0.32)	(0.34)
J	9.9	10.7	(0.39)	(0.42)
K	8.64	8.69	(0.340)	(0.342)
L	5.1	5.6	(0.20)	(0.22)
M	17.0	17.5	(0.67)	(0.69)
N	27.4	28.2	(1.08)	(1.11)
O	7.11	7.16	(0.280)	(0.282)
P	9.73	9.78	(0.383)	(0.385)

**FIG. A2.1 Dimensions for Thermometer Adapter, Ferrule, and Packing Ring**

### A3. THERMOMETER SPECIFICATIONS

**TABLE A3.1 IP Thermometer Specifications**

NOTE—The stem shall be made with an enlargement having a diameter of 1.5 to 2.0 mm greater than the stem and a length of 3 to 5 mm, the bottom of the enlargement being 64 to 66 mm from the bottom of the bulb. These dimensions shall be measured with the test gage shown in Fig. A3.1.

Name	IP 15C	IP 16C	IP 101C
	Pensky-Martens Low	Pensky-Martens High	Pensky-Martens Medium
Range	−5 to +110°C	90 to 370°C	20 to 150°C
Graduation	0.5°C	2°C	1°C
Immersion, mm	57	57	57
Overall length ± 5 mm	290	280 ± 10	290
Stem diameter, mm	6.0 to 7.0	6.0 to 7.0	6.0 to 7.0
Bulb shape	cylindrical	cylindrical	cylindrical
Bulb length, mm	9 to 13	7 to 10	9 to 13
Bulb diameter, mm	not less than 5.5 and not greater than stem	not less than 4.5 and not greater than stem	not less than 5.5 and not greater than stem
Length of graduated portion, mm	140 to 175	143 to 180	140 to 175
Distance bottom of bulb to, mm	0°C 85 to 95	90°C 80 to 90	20°C 85 to 95
Longer lines at each	1 and 5°C	10 and 20°C	5°C
Figured at each	5°C	20°C	5°C
Expansion chamber	required	required	required
Top finish	ring	ring	ring
Scale error not to exceed ±	0.5°C	1 to 260°C 2°C above 260°C	1°C
See notes	1 and Table A3.3 for emergent stem temperatures	1 and Table A3.3 for emergent stem temperatures	1 and Table A3.3 for emergent stem temperatures

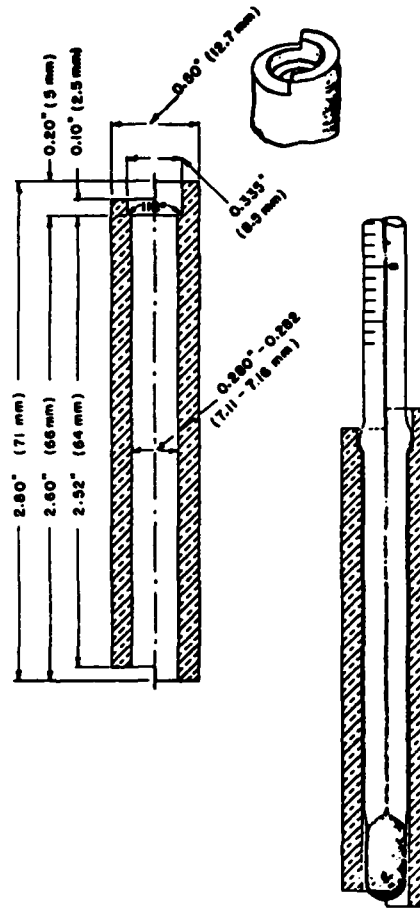
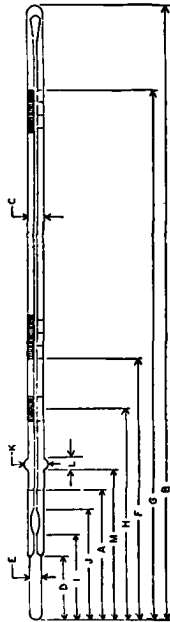

FIG. A3.1 Test Gage for Checking Enlargements on Thermometers



**TABLE A3.2 Specifications for ASTM Thermometers**  
 All dimensions are in millimetres.  
 See Table A3.3 for Standardization Temperature.



ASTM No. and Name	Range	For Test at	Im-mer-sion	Graduations			Scale Error max	Special In-scrip-tion	Expan-sion Cham-ber	Total Length, ±5	Bulb		Scale Location			Ice Point Scale		Contraction Chamber		Stem Enlargement	
				Sub-divi-sions	Long Lines	Num-ber at Each					Permit Heat-ing to	Stem OD	Length	OD	Bot-tom of Bulb to Line at	Dis-tance to	Bot-tom of Bulb to Line at	Dis-tance to	Dis-tance to	Dis-tance to	Dis-tance to
				0.5°C	1°C	5°C	0.5°C		Permit Heat-ing to	B	C	D	E	F	G	H	I	J	K	L	M
9C-62 Pensky- Martens, Low-Range Tag Closed Tester 9F-62	-5 to +110°C		57	0.5°C	1°C	5°C	0.5°C	ASTM 9C or 9F 57 mm IMM	160°C	287	6.0 to 7.0	9.0 to 13	stem	85 to 98	100°C 221 to 237				7.5 to 8.5	2.5 to 5.0 <sup>d</sup>	64 to 66
10C-62 Pensky- Martens, High-Range 10F-62	90 to 370°C		57	2°C	10°C	20°C	<sup>a</sup>	ASTM 10C or 10F 57 mm IMM	<sup>c</sup>	287	6.0 to 7.0	8.0 to 10.0	4.5 to 6.0	86 to 99	360°C 227 to 245				7.5 to 8.5	2.5 to 5.0 <sup>d</sup>	64 to 66

<sup>a</sup> Scale error: 1°C up to 260°C; 2°C over 260°C.

<sup>b</sup> Scale error: 2.5°F up to 500°F; 3.5°F over 500°F.

<sup>c</sup> An expansion chamber is provided for relief of gas pressure to avoid distortion of the bulb at higher temperatures. It is not for the purpose of joining mercury separations; and under no circumstances should the thermometer be heated above the highest temperature reading.

<sup>d</sup> The length of the enlargement, and the distance from the bottom of the enlargement to the bottom of the bulb shall be measured with the test gage shown in Fig. A3.1.

**TABLE A3.3 Standardization Temperatures**

NOTE—The emergent column temperatures are those attained when using the thermometers in the test equipment for which the thermometers were originally designed. In some cases these temperatures are markedly different from those realized during standardization.

Temperature	Average Temperature of Emergent Column	Temperature	Average Temperature of Emergent Column	Temperature	Average Temperature of Emergent Column	Temperature	Average Temperature of Emergent Column
Thermometer 9C (-5 to +100°C)		Thermometer 9F (20 to 230°F)		Thermometer 10C (90 to 370°C)		Thermometer 10F (200 to 700°F)	
0°C	19°C	32°F	66°F	100°C	61°C	212°F	141°F
35°C	28°C	100°F	86°F	200°C	71°C	390°F	159°F
70°C	40°C	160°F	106°F	300°C	87°C	570°F	180°F
105°C	50°C	220°F	123°F	370°C	104°C	700°F	220°F
IP 15C (-7 to 110°C)		IP 15F (20 to 230°F)		IP 16C (90 to 370°C)		IP 16F (20 to 700°F)	
0°C	19°C	32°F	66°F	100°C	61°C	200°F	140°F
20°C	20°C	70°F	70°F	150°C	65°C	300°F	149°F
40°C	31°C	100°F	86°F	200°C	71°C	400°F	160°F
70°C	40°C	150°F	104°F	250°C	78°C	500°F	175°F
100°C	48°C	212°F	118°F	300°C	87°C	600°F	195°F
				350°C	99°C	700°F	220°F

**TABLE A3.4 Specifications for Medium-Range Pensky-Martens**

ASTM No. 88F (88C) Vegetable Oil Flash Thermometer

Name	Medium Range Pensky-Martens	
Reference Fig. No.	5	
Range	10-200°C	50-392°F
For test at		
A Immersion, mm	57	
Graduations:		
Subdivisions	0.5°C	1°F
Long lines at each	1°C and 5°C	5°F
Numbers at each	5°C	10°F
Scale error, max	0.5°C	1°F
Special inscription	ASTM 88F(88C) 57 mm IMM	
Expansion chamber:		
Permit heating to	205°C	400°F
B Total length, mm	285 to 295	
C Stem OD, mm	6.0 to 7.0	
D Bulb length, mm	8.0 to 12.0	
E Bulb OD, mm	>4.5 and <stem <sup>A</sup>	
Scale location:		
Bottom of bulb to line at	20°C	68°F
F Distance, mm	80 to 90	
G Length of graduated portion, mm	145 to 180	
Ice-point scale:		
Range		
H Bottom of bulb to ice-point, mm		
Contraction chamber:		
I Distance to bottom, min, mm		
J Distance to top, max, mm		
Stem enlargement:		
K OD, mm	7.5 to 8.5	
L Length, mm	2.5 to 5.0 <sup>A</sup>	
M Distance to bottom, mm	64 to 66	

<sup>A</sup> Bulb OD shall be greater than 4.5 mm and less than the outside diameter of the stem (C).

*The American Society for Testing and Materials takes no position respecting the validity of any patent rights asserted in connection with any item mentioned in this standard. Users of this standard are expressly advised that determination of the validity of any such patent rights, and the risk of infringement of such rights, are entirely their own responsibility.*

*This standard is subject to revision at any time by the responsible technical committee and must be reviewed every five years and if not revised, either reapproved or withdrawn. Your comments are invited either for revision of this standard or for additional standards and should be addressed to ASTM Headquarters. Your comments will receive careful consideration at a meeting of the responsible technical committee, which you may attend. If you feel that your comments have not received a fair hearing you should make your views known to the ASTM Committee on Standards, 1916 Race St., Philadelphia, PA 19103.*



## Standard Test Method for Flash Point and Fire Point of Liquids by Tag Open-Cup Apparatus<sup>1</sup>

This standard is issued under the fixed designation D 1310; the number immediately following the designation indicates the year of original adoption or, in the case of revision, the year of last revision. A number in parentheses indicates the year of last reapproval. A superscript epsilon ( $\epsilon$ ) indicates an editorial change since the last revision or reapproval.

<sup>ε1</sup>NOTE—Keywords were added editorially in September 1990.

### 1. Scope

1.1 This test method covers the determination by Tag Open-Cup Apparatus of the flash point and fire point of liquids having flash points between 0 and 325°F (–18 and 165°C) and fire points up to 325°F.

1.2 This test method, when applied to paints and resin solutions that tend to skin over or that are very viscous, gives less reproducible results than when applied to solvents.

NOTE 1—In order to conserve time and sample, the fire point of a material may be determined by the Tag Open-Cup Method by continuing the heating of the specimen to its fire point. Fire points may also be determined by Test Method D 92, which should be used for fire points beyond the scope of this test method.

1.3 *This standard should be used to measure and describe the properties of materials, products, or assemblies in response to heat and flame under controlled laboratory conditions and should not be used to describe or appraise the fire hazard or fire risk of materials, products, or assemblies under actual fire conditions. However, results of this test may be used as elements of a fire risk assessment which takes into account all of the factors pertinent to an assessment of the fire hazard of a particular end use.*

1.4 *This standard does not purport to address the safety problems associated with its use. It is the responsibility of the user of this standard to establish appropriate safety and health practices and determine the applicability of regulatory limitations prior to use.*

### 2. Referenced Documents

#### 2.1 ASTM Standards:

D 92 Test Method for Flash and Fire Points by Cleveland Open Cup<sup>2</sup>

D 850 Method for Distillation of Industrial Aromatic Hydrocarbons and Related Materials<sup>3</sup>

D 1015 Test Method for Freezing Points of High-Purity Hydrocarbons<sup>4</sup>

D 1016 Test Method for Purity of Hydrocarbons from Freezing Points<sup>4</sup>

D 1078 Test Method for Distillation Range of Volatile Organic Liquids<sup>3</sup>

D 1364 Test Method for Water in Volatile Solvents (Fischer Reagent Titration Method)<sup>3</sup>

D 2268 Method for Analysis of High-Purity *n*-Heptane and Isooctane by Capillary Gas Chromatography<sup>5</sup>

D 2699 Test Method for Knock Characteristics of Motor Fuels by the Research Method<sup>6</sup>

D 2700 Test Method for Knock Characteristics of Motor and Aviation Fuels by the Motor Method<sup>6</sup>

E 1 Specification for ASTM Thermometers<sup>7</sup>

E 29 Practice for Using Significant Digits in Test Data to Determine Conformance With Specification<sup>8</sup>

### 3. Terminology

#### 3.1 Definition:

3.1.1 *flash point*—the lowest temperature, corrected to a pressure of 760 mm Hg (101.3 kPa, 1013 mbar), at which application of an ignition source causes the vapor of the specimen to ignite under specified conditions of test.

#### 3.2 Description of Term Specific This Standard:

3.2.1 *fire point*—the lowest temperature at which a specimen sustains burning for a minimum of 5 s by the procedure described.

### 4. Summary of Method

4.1 The specimen is placed in the cup of a Tag Open-Cup Apparatus and heated at a slow, but constant rate. A small test flame is passed at a uniform rate across the cup at specified intervals until a flash occurs. To determine the fire point, the test is continued until the application of the test flame causes the specimen to ignite and burn for at least 5 s.

### 5. Significance and Use

5.1 Flash point and fire point of a liquid are physical properties that may be used to define their flammability

<sup>1</sup> This test method is under the jurisdiction of ASTM Committee D-1 on Paint and Related Coatings and Materials and is the direct responsibility of Subcommittee D01.22 on Health and Safety.

Current edition approved April 25, 1986. Published June 1986. Originally published as D 1310 – 52 T. Last previous edition D 1310 – 85.

<sup>2</sup> Annual Book of ASTM Standards, Vols 05.01 and 10.03.

<sup>3</sup> Annual Book of ASTM Standards, Vol 06.03.

<sup>4</sup> Annual Book of ASTM Standards, Vols 05.01 and 06.03.

<sup>5</sup> Annual Book of ASTM Standards, Vol 05.02.

<sup>6</sup> Annual Book of ASTM Standards, Vol 05.04.

<sup>7</sup> Annual Book of ASTM Standards, Vols 05.03 and 14.03.

<sup>8</sup> Annual Book of ASTM Standards, Vols 02.03, 03.01, 03.03, 03.05 and 14.02.

hazards. The flash point may be used to classify materials in government regulations.

**6. Apparatus**

6.1 *Flash Tester—Tag Open-Cup Apparatus* (Fig. 1), as described in detail in Annex A1.

6.2 *Shield*, as described in detail in Annex A1.

6.3 *Thermometers*, conforming to Specification E 1, as listed in Table 1.

6.4 *Flasks*, 500-mL, two, with rubber stoppers.

**7. Materials**

7.1 *Water-Glycol Solution* (1 + 1), for flash points from 0 to 200°F (−18 to 93°C).

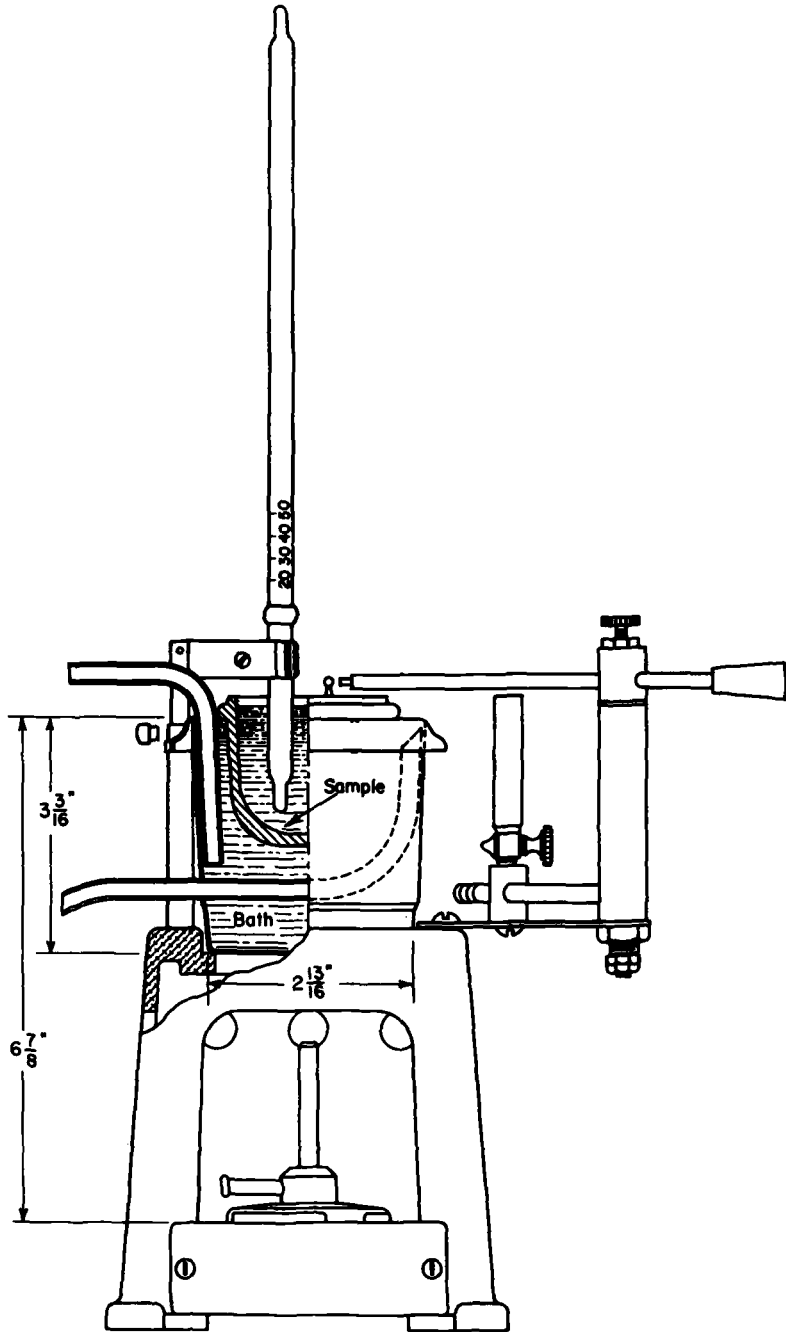

**Metric Equivalents**

in.	mm
2 <sup>13</sup> / <sub>16</sub>	71.4
3 <sup>3</sup> / <sub>16</sub>	81
6 <sup>7</sup> / <sub>8</sub>	174.5

**FIG. 1 Tag Open-Cup Apparatus**

**TABLE 1 Thermometers**

	ASTM Thermometer Number	Thermometer Range	Thermometer Subdivisions
<i>Flash Point/ Fire Point:</i>			
0 to 60°F	33F-75	-36.5 to +107.5°F	0.5°F
-18 to 15°C	33C-75	-38 to +42°C	0.2°C
60 to 200°F	9F-75	20 to 230°F	1°F
15 to 93°C	9C-75	-5 to 110°C	0.5°C
200 to 325°F	35F-79	194 to 338°F	0.5°F
93 to 165°C	35C-79	90 to 170°C	0.2°C

7.2 *Solid Carbon Dioxide-Acetone or other Coolant.*

7.3 *Silicone Fluid*, inert, high boiling, having a flash point exceeding the test temperatures by at least 110°F (60°C) for flash and fire points from 200 to 325°F (93 to 165°C).

7.4 *n-Heptane*,<sup>9</sup> for determination of flash points from 0 to 60°F (-18 to 16°C). See Annex A2 for specifications.

7.5 *p-Xylene*,<sup>9</sup> for determination of flash points from 60 to 200°F (16 to 93°C). See Annex A2 for specifications.

7.6 *Isopropanol (isopropyl alcohol)*,<sup>10</sup> for determination of flash points from 60 to 200°F (16 to 93°C). See Annex A2 for specifications.

7.7 *Diethylene Glycol*,<sup>11</sup> for determination of flash points from 200 to 325°F (93 to 165°C). See Annex A2 for specifications.

## 8. Assembly and Preparation of Apparatus

8.1 Place the tester in a level position on a solid table free of vibration, in a location free of perceptible draft, and in a dim light. Maintain a room temperature of 75 ± 5°F (24 ± 3°C) throughout the test. Other room temperatures may be specified on agreement between buyer and seller.

NOTE 2—For materials with vapors or products of pyrolysis that are objectionable, it is permissible to place the apparatus with shield in a fume hood with the ventilation turned off. The ventilation can then be turned on at completion of the test or when and if fumes become objectionable.

8.2 Adjust the horizontal and vertical positions of the taper so that the jet passes on the circumference of a circle having a radius of at least 6 in. (150 mm). The jet should pass across the center of the cup at right angles to a diameter passing through the thermometer and in a plane 1/8 in. (3.2 mm) above the upper edge of the cup as measured from the center of the orifice.

8.3 Using the leveling device as a gage, adjust the height of the taper so that the center of the orifice is exactly 1/8 in. (3.2 mm) above the top edge of the glass cup when it is in place. It is imperative that this adjustment be made as accurately as possible. Raising or lowering the taper can be achieved by bending it slightly or preferably by adding and removing thin

<sup>9</sup> Satisfactory *n*-heptane and *p*-xylene can be obtained from Special Products Division, Chemical Department, Phillips Petroleum Company, Drawer O, Borger, TX 79607.

<sup>10</sup> Satisfactory isopropanol may be obtained from Exxon Chemical, Americus P. O. Box 3272, Houston, TX 77001, Shell Chemical Co., One Shell Plaza, Houston, TX 77002, or Union Carbide Co., P. O. Box 8361, South Charleston, WV 25303.

<sup>11</sup> Satisfactory diethylene glycol may be obtained from Union Carbide Co., S. Charleston, WV.

metal shims as required from between the taper and the vertical supporting member of the swivel holder.

8.4 With the glass cup in place in the bath, adjust the thermometer holder so that the thermometer is supported firmly in a vertical position halfway between the center and edge of the cup and on a line passing through the center of the cup and the pivot of the taper. Place the thermometer so that the bottom of the bulb is 1/4 in. (6.4 mm) from the inner bottom of the cup.

8.5 Set the draft shield around the tester so that the sides form right angles with each other and the tester is well toward the back of the shield.

## 9. Procedure

### 9.1 Flash Points from 0 to 60°F (-18 to 16°C):

NOTE 3—**Caution**—Meticulous attention to all details relating to the taper, size of taper flame, rate of temperature increase, and rate of passing the taper over the sample is necessary for good results.

9.1.1 Equip two 500-mL flasks with rubber stoppers through which are inserted ASTM 33F (33C) thermometers. Cool a quantity of 1 + 1 water-glycol solution in one stoppered 500-mL flask to approximately -20°F (-30°C) by immersing the flask in a solid carbon dioxide-acetone bath or other coolant. Use extreme care not to contaminate the water-glycol solution with either acetone or carbon dioxide.

9.1.2 Pour the cooled water-glycol solution into the tester bath to a predetermined level 1/8 in. (3.2 mm) below the top when the cup is in place. An overflow is desirable for controlling the liquid level in the bath.

9.1.3 At the same time the water-glycol coolant is being chilled, cool a portion of the sample to approximately -10°F (-25°C) in the second stoppered 500-mL flask. If solid carbon dioxide and acetone or other volatile solvents are used as a coolant, extreme care must be exercised to avoid contamination of the sample. Cool the glass cup and place it in the bath. Position the appropriate thermometer (Table 1) as described in 8.4 and fill the cup with cooled sample to a depth approximately 1/8 in. (3.2 mm) below the edge as determined by the leveling device.

NOTE 4—Remove all bubbles from the surface of the liquid before starting a determination.

9.1.4 Light the ignition flame and adjust it to form a flame of spherical shape matching in size the 5/32-in. (4.0-mm) sphere on the apparatus or the 5/32-in. hole in the leveling device.

9.1.5 Make the final adjustment of the specimen level in the cup when the temperature is 20°F (10°C) below the anticipated flash point. Two trial determinations may be necessary to select the proper temperature at which to adjust the liquid level. A hypodermic syringe or medicine dropper provides a convenient means of adding or removing sample from the cup.

9.1.6 Allow the temperature of the specimen to increase spontaneously without applying any heat until the rate of temperature rise decreases to 2°F (1°C)/min. At this point, apply heat to maintain an increase in temperature at a rate of 2 ± 0.5°F (1 ± 0.25°C)/min.

NOTE 5—With viscous materials, this rate of heating cannot always be maintained.

9.1.7 Determine the approximate flash point by passing the taper flame across the specimen at intervals of 2°F (1°C). Make the first pass of the taper flame immediately after the final adjustment of the specimen level, as in 9.1.5. The time required to pass the ignition flame across the surface of the liquid should be 1 s. Each pass must be in one direction only, and the taper should be kept in the “off” position at one or the other end of the swing except when the flame is applied to the specimen. In case the material tends to “creep” over the edge of the cup, carefully wipe the edge with absorbant tissue to remove frost and liquid just prior to passage of the taper over the cup.

NOTE 6—When determining the flash point or fire point, or both, of viscous liquids and those liquids that tend to form a surface film, the following procedure is suggested: About 15 s before the taper is passed over the surface, insert the end of a stirring rod to a depth of about ½ in. (15 mm) in approximately a vertical position. Move the rod from side-to-side of the cup for three or four complete passes following approximately the path of the taper, remove, and make the test.

NOTE 7—Discontinue heating and checking flash point if the specimen boils before flashing. Record that the material has no flash point prior to boiling.

9.1.8 Continue with procedure in 9.4.

9.2 *Flash Points from 60 to 200°F (16 to 93°C)* (See Notes 3, 4, 5, and 6):

9.2.1 Fill the bath with cold water or water-glycol solution to a predetermined level ⅛ in. (3.2 mm) below the top when the cup is in place. The bath liquid should be at least 30°F (17°C) below the anticipated flash point.

9.2.2 If necessary, cool a portion of the sample to at least 20°F (10°C) below the anticipated flash point. Exercise adequate care to avoid contamination of the sample with coolant liquid or vapors. Fill the glass cup with the cooled sample to a depth approximately ⅛ in. (3.2 mm) below the edge as determined by the leveling device with the proper thermometer (see Table 1) positioned as described in 8.4.

9.2.3 For final adjustment of the specimen level, see 9.1.5.

9.2.4 Light the ignition flame and adjust it as described in 9.1.4.

9.2.5 Apply heat to the liquid bath and adjust so that the temperature of the specimen increases at a rate of  $2 \pm 0.5^\circ\text{F}$  ( $1 \pm 0.25^\circ\text{C}$ )/min.

9.2.6 Determine the approximate flash point by passing the taper flame across the specimen at intervals of 2°F (1°C) as described in 9.1.7.

9.2.7 Continue with procedure in 9.4.

9.3 *Procedure for Flash Points from 200 to 325°F (93 to 165°C)* (See Notes 3, 4, 5, and 6):

9.3.1 Fill the bath with a high-boiling inert silicone fluid to a predetermined level ⅛ in. (3.2 mm) below the top when the cup is in place.

9.3.2 With the appropriate thermometer (see Table 1) properly positioned (8.4), fill the glass cup with sample at room temperature to a depth slightly more than ⅛ in. (3.2 mm) below the edge as determined by the leveling device.

9.3.3 For final adjustment of the specimen level, see 9.1.5.

9.3.4 Light the ignition flame and adjust it as described in 9.1.4.

9.3.5 Apply full heat to the liquid bath and when the temperature of the specimen reaches approximately 190°F (90°C), adjust the heat input so that the temperature of the specimen increases at a rate of  $2 \pm 0.5^\circ\text{F}$  ( $1 \pm 0.25^\circ\text{C}$ )/min.

NOTE 8—The heaters on some testers do not have sufficient capacity to maintain the proper rate of heating when the temperature approaches 250°F (120°C) or above. The heat input to the liquid bath may be increased if necessary by using a variable transformer to increase the voltage to the heater or by wrapping the bath with electrical heating tape. The application of suitable insulation to the outside of the bath to prevent heat loss is also permissible. The important factor is to maintain the rate of temperature increase of the specimen at  $2 \pm 0.5^\circ\text{F}$  ( $1 \pm 0.25^\circ\text{C}$ )/min.

9.3.6 Determine the approximate flash point by passing the taper flame across the specimen at intervals of 2°F (1°C) as described in 9.1.7.

9.4 Determine and record not less than three test values, as follows:

9.4.1 After the initial test to determine the approximate flash point of the materials, repeat the procedure by cooling a fresh portion of the sample, the glass cup, the bath solution, and the thermometer to more than 20°F (10°C) below the approximate flash point. When the temperature of the specimen is exactly 20°F below the approximate flash point, adjust the center of the liquid level to ⅛ in. (3.2 mm) below the upper edge of the cup as determined with the leveling device placed across the diameter of the cup.

9.4.2 Resume heating, or allow the temperature to rise spontaneously in the case of materials flashing below 60°F (16°C). Following the instructions given in 9.1.7, pass the taper flame across the specimen at two intervals of 5°F (3°C) and then at intervals of 2°F (1°C) until the flash point is reached.

9.5 *Fire Point (Sustained Burning):*

9.5.1 Except for the initial test, after determining the flash point, continue heating the apparatus so that the temperature of the specimen increases at the rate of  $2 \pm 0.5^\circ\text{F}$  ( $1 \pm 0.25^\circ\text{C}$ )/min. At intervals of 2°F (1°C), pass the taper across the surface of the specimen as described in 9.1.7 and in Note 7 and determine the temperature at which burning is sustained for 5 s after ignition (fire point). Time the duration of burning from the time the taper (ignition source) has completed its passage across the surface of the liquid.

9.5.2 Determine and record the results obtained from the continuation of three or more flash point tests (9.4).

## 10. Standardization and Calibration

NOTE 9—The calibration procedure provided in this test method eliminates the effect of barometric pressure if calibration and tests are run at the same pressures.

10.1 *Flash Points from 0 to 60°F (−18 to 16°C)* (see Notes 9 and 10):

10.1.1 Make at least five determinations of the flash point (9.1) of standard *n*-heptane that meets the specifications set forth in Annex A2, and calculate the mean. If the mean differs from 23°F (−5°C) by more than  $\pm 3^\circ\text{F}$  ( $\pm 1.5^\circ\text{C}$ ), adjust the height of the taper and repeat the standardization.

NOTE 10—The height of the taper arm is very important. Raising the taper 0.01 in. (0.25 mm) increases the flash point about 2°F (1°C). Therefore, if it is suspected that the taper arm has been jarred or bent, the apparatus should be recalibrated. Each unit of apparatus should have its calibration checked about once a week, if in constant use, or on each occasion of use, when used only occasionally.

10.1.2 Calculate the correction as follows:

$^\circ\text{F} = 23^\circ\text{F}$  minus mean observed flash point of *n*-heptane in  $^\circ\text{F}$   
 $^\circ\text{C} = -5^\circ\text{C}$  minus mean observed flash point of *n*-heptane in  $^\circ\text{C}$

Round the correction to 1°F (0.5°C) in accordance with Recommended Practice E 29. Apply this correction to all flash-point determinations between 0 and 60°F (-18 to 16°C).

10.2 *Flash Points from 60 to 200°F (16 to 93°C)* (see Notes 9 and 10):

10.2.1 Make three determinations of the flash point (9.2) of standard *p*-xylene and the standard isopropyl alcohol that meet specifications set forth in Annex A2. Calculate the mean for each compound. If the difference between the values for these two compounds is less than 15°F (8.5°C) or more than 27°F (16°C), repeat the determinations or obtain fresh standards.

10.2.2 Calculate the correction factor as follows:

$$\begin{aligned} x^{\circ}\text{F} &= 92^{\circ}\text{F} \text{ minus mean flash point of } p\text{-xylene in } ^{\circ}\text{F} \\ x^{\circ}\text{C} &= 33^{\circ}\text{C} \text{ minus mean flash point of } p\text{-xylene in } ^{\circ}\text{C} \\ y^{\circ}\text{F} &= 71^{\circ}\text{F} \text{ minus mean flash point of isopropanol in } ^{\circ}\text{F} \\ y^{\circ}\text{C} &= 22^{\circ}\text{C} \text{ minus mean flash point of isopropanol in } ^{\circ}\text{C} \\ \text{correction factor} &= (x + y)/2 \end{aligned}$$

Round the correction to the nearest 1°F (0.5°C) in accordance with Practice E 29. Apply this correction to all flash point determinations between 60 and 200°F (16 and 93°C).

10.3 *Flash Points from 200 to 325°F (93 to 165°C)* (see Notes 9 and 10):

10.3.1 Make at least five determinations of the flash point (9.3) of standard diethylene glycol that meets the specifications set forth in Annex A2. Calculate the mean and, if it differs from 295°F (146°C) by more than ±10°F (±5.5°C), adjust the height of the taper and repeat the standardization.

10.3.2 Calculate the correction factor as follows:

$$\begin{aligned} ^{\circ}\text{F} &= 295^{\circ}\text{F} \\ &\quad \text{minus mean observed flash point of diethylene glycol in } ^{\circ}\text{F} \\ ^{\circ}\text{C} &= 146^{\circ}\text{C} \\ &\quad \text{minus mean observed flash point of diethylene glycol in } ^{\circ}\text{C} \end{aligned}$$

Round the correction to 1°F (0.5°C) in accordance with Practice E 29. Apply this correction to all flash-point determinations between 200 and 325°F (93 and 165°C).

10.4 Correct the fire-point results with the applicable flash-point factor determined in 10.1, 10.2, or 10.3.

## 11. Report

11.1 Report the mean of not less than three corrected recorded tests, other than the initial test, to the nearest 1°F (0.5°C). Three multiple runs are acceptable for averaging if the difference between the extreme values does not exceed 7°F (4°C) (95 % confidence level).

## 12. Precision<sup>12</sup>

12.1 The following criteria should be used for judging the acceptability of results between 0 and 200°F (-18 and 93°C) at the 95 % confidence level.

12.1.1 *Repeatability*—Two results, each the mean of three determinations, obtained by the same operator should be considered suspect if they differ by more than 4°F (2°C).

12.1.2 *Reproducibility*—Two results, each the mean of three determinations, obtained by operators in different laboratories should be considered suspect if they differ by more than 7°F (4°C).

12.2 The following criteria should be used for judging flash points between 200 and 325°F (93 and 165°C) at the 95 % confidence level.

12.2.1 *Repeatability*—Two results, each the mean of three determinations, obtained by the same operator should be considered suspect if they differ by more than 9°F (5°C).

12.2.2 *Reproducibility*—Two results, each the mean of three determinations, obtained by operators in different laboratories should be considered suspect if they differ by more than 12°F (7°C).

12.3 On the basis of an interlaboratory test of the method using viscous, heavily-pigmented materials that tended to form a surface film, the within-laboratory standard deviation was found to be 3°F (2°C) and the between-laboratories standard deviation was found to be 7°F (4°C). Based on these standard deviations, the following criteria should be used for judging the acceptability of results at the 95 % confidence level:

12.3.1 *Repeatability*—Two results, each the mean of three determinations, obtained by the same operator on different days should be considered suspect if they differ by more than 9°F (5°C).

12.3.2 *Reproducibility*—Two results, each the mean of three determinations, obtained by operators in different laboratories should be considered suspect if they differ by more than 24°F (13°C).

12.4 The precision of fire points will be determined. See Test Method D 92 for precision using the Cleveland Open Cup.

12.5 *Bias*—No estimate of bias of flash point and fire point tests can be determined as no absolute values are available. The tests are equipment and method dependent.

## 13. Keywords

13.1 fire point; flash point; liquids; paints; resin solutions; Tag tester

<sup>12</sup> Supporting data are available from ASTM Headquarters. Request RR: D01 - 1002.

ANNEXES

(Mandatory Information)

A1. APPARATUS

A1.1 *Tag Open-Cup Apparatus*, shown in Fig. 1. It consists of the following parts, which must conform to the dimensions shown, and have the additional characteristics as noted:

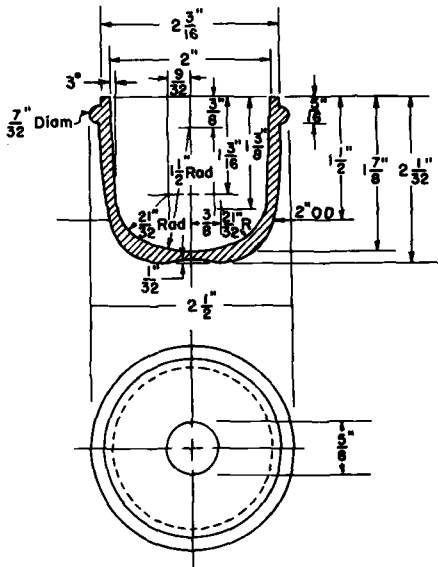

Metric Equivalents

in.	mm	in.	mm
1/32	0.8	19/16	30.1
7/32	5.5	13/8	34.9
9/32	7.0	1 1/2	38.1
5/16	7.5	1 7/8	47.6
3/8	9.5	2	50.8
5/8	15.9	2 1/32	51.6
2 1/32	16.6	2 9/16	55.5
		2 1/2	63.5

FIG. A1.1 Glass Test Cup

A1.1.1 *Copper Bath*, preferably equipped with a constant-level overflow so placed as to maintain the bath liquid level 1/8 in. (3.2 mm) below the rim of the glass cup.

A1.1.2 *Thermometer Holder*, supplied with the tester as shown in Fig. 1 to support the thermometer firmly in a vertical position.

NOTE A1.1—The spring clamp holding the thermometer part may be replaced by a set-screw facing out away from the bath as shown in Fig. 1. This may make it easier and safer to extinguish the fire after the fire point has been reached.

A1.1.3 *Glass Test Cup* (Fig. A1.1), of molded clear glass, annealed, heat-resistant, and free from surface defects.

A1.1.4 *Leveling Device*, or gage, for proper adjustment of the liquid in the cup (Fig. A1.2) made of polished aluminum or stainless steel 1/8 in. (3.2 mm) thick, with two projections for adjusting the liquid level in the glass cup to 0.125 in. ± 0.003 in. (3.18 ± 0.08 mm) below the top edge or rim of the cup. This leveling device may also be used to adjust the size of the test flame and for gaging the height of the taper above the edge of the cup.

A1.1.5 *“Micro” or Small Gas Burner*, of suitable dimensions for heating the bath. A screw clamp may be used to help regulate the gas. A small electric heater controlled by a variable power transformer may be used.

A1.1.6 *Ignition Taper*, a small, straight blow-pipe type gas burner with the tip approximately 1/16 in. (1.5 mm) in diameter and the orifice 1/32 in. (0.8 mm) in diameter. The ignition taper should be maintained in a fixed horizontal plane above the test cup by means of a swivel device so that the test flame passes on the circumference of a circle having a radius of at least 6 in. (150 mm).

A1.1.7 *Draft Shield*, consisting of two rectangular sheets of noncombustible material, 24 by 28 in. (610 by 710 mm), fastened together along the 28-in (710-mm) side, preferably by hinges. A triangular sheet, 24 by 24 by 34 in. (610 by 610 by 860 mm), is fastened by hinges to one of the lateral sheets (to form a top when shield is open). The interior of the draft shield shall be painted a flat black. A draft-free fume hood may be used.



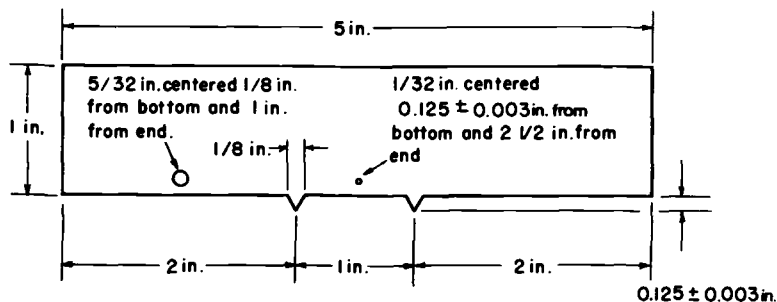

Metric Equivalents

in.	mm
1/32	0.8
1/8	3.2
0.125 ± 0.003	3.18 ± 0.08
5/32	4.0
1	25.4
2	50.8
2 1/2	63.5
5	127

FIG. A1.2 Leveling Device for Adjusting Liquid Level in Test Cup, Height of Taper above Cup, and Size of Test Flame

## A2. SPECIFICATIONS FOR *n*-HEPTANE, *p*-XYLENE, ISOPROPANOL, AND DIETHYLENE GLYCOL

A2.1 *Specifications for n-Heptane*<sup>9</sup> (*ASTM Knock Test Reference Fuel*)—*n*-Heptane shall conform to the following requirement:

A2.1.1 *Purity*—99.75 % when determined by Method D 2268.

NOTE A2.1—This is the same grade of *n*-heptane specified in Test Methods D 2699 and D 2700.

A2.2 *Specifications for p-Xylene (Flash Point Check Grade)*<sup>9</sup>—*p*-Xylene shall conform to the following requirements:

A2.2.1 *Specific Gravity*—15.56/15.56°C—0.863 ± 0.003 max.

A2.2.2 *Boiling Range*—2°C max from start to dry point, when tested in accordance with Method D 850 or Test Method D 1078. The range shall include the boiling point of pure *p*-xylene, which is 281.03°F (138.35°C).

A2.2.3 *Freezing point* 11.23°C, min calculated in accordance with Test Method D 1016, from the experimentally determined freezing point, measured by Test Method D 1015.

A2.3 *Specifications for Isopropanol (Isopropyl Alcohol) 91 % (Volume)*:<sup>10</sup> Isopropanol shall conform to the following requirements:

A2.3.1 *Specific Gravity*—0.8180 ± 0.0005 at 20/20°C as determined by means of a calibrated pycnometer.

A2.3.2 *Distillation Range*—Shall entirely distill within a 1.0°C range that shall include the temperature 80.4°C as determined by Test Method D 1078.

A2.4 *Specifications for Diethylene Glycol*<sup>11</sup>—Diethylene glycol shall conform to the following requirements:

A2.4.1 *Specific Gravity*—1.1185 ± 0.0015 at 20/20°C as determined by means of a calibrated pycnometer.

A2.4.2 *Distillation Range*—Shall entirely distill within a 5.0 range which shall include the temperature 245.8°C as determined by Test Method D 1078.

A2.4.3 *Water*—Not more than 0.2 % as determined by Test Method D 1364.

The American Society for Testing and Materials takes no position respecting the validity of any patent rights asserted in connection with any item mentioned in this standard. Users of this standard are expressly advised that determination of the validity of any such patent rights, and the risk of infringement of such rights, are entirely their own responsibility.

This standard is subject to revision at any time by the responsible technical committee and must be reviewed every five years and if not revised, either reapproved or withdrawn. Your comments are invited either for revision of this standard or for additional standards and should be addressed to ASTM Headquarters. Your comments will receive careful consideration at a meeting of the responsible technical committee, which you may attend. If you feel that your comments have not received a fair hearing you should make your views known to the ASTM Committee on Standards, 1916 Race St., Philadelphia, PA 19103.



# Standard Test Methods for Flash Point of Liquids by Setaflash Closed-Cup Apparatus<sup>1</sup>

This standard is issued under the fixed designation D 3278; the number immediately following the designation indicates the year of original adoption or, in the case of revision, the year of last revision. A number in parentheses indicates the year of last reapproval. A superscript epsilon ( $\epsilon$ ) indicates an editorial change since the last revision or reapproval.

*This standard has been approved for use by agencies of the Department of Defense. Consult the DoD Index of Specifications and Standards for the specific year of issue which has been adopted by the Department of Defense.*

## 1. Scope

1.1 These test methods cover procedures for determining whether a material does or does not flash at a specified temperature or for determining the lowest finite temperature at which a material does flash when using a Setaflash Tester. The test methods are applicable to paints, enamels, lacquers, varnishes, and related products having a flash point between 32 and 230°F (0 and 110°C) and viscosity lower than 150 St at 77°F (25°C).

NOTE 1—Tests at higher or lower temperatures are possible.

NOTE 2—More viscous materials may be tested in accordance with Annex A4.

NOTE 3—Organic peroxides may be tested in accordance with Annex A5, which describes the applicable safety precautions.

NOTE 4—The U.S. Department of Labor (OSHA, Hazard Communications), the U.S. Department of Transportation (RSPA), and the U.S. Environmental Protection Agency (EPA) have specified Test Methods D 3278 as one of several acceptable methods for the determination of flash point of liquids in their regulations.

NOTE 5—These test methods are similar to International Standards ISO 3679 and ISO 3680.

1.2 *This standard should be used to measure and describe the properties of materials, products, or assemblies in response to heat and flame under controlled laboratory conditions and should not be used to describe or appraise the fire hazard or fire risk of materials, products, or assemblies under actual fire conditions. However, results of this test may be used as elements of a fire risk assessment which takes into account all factors pertinent to an assessment of the fire hazard of a particular end use.*

1.3 *This standard may involve hazardous materials, operations, and equipment. This standard does not purport to address all of the safety problems associated with its use. It is the responsibility of the user of this standard to establish appropriate safety and health practices and determine the applicability of regulatory limitations prior to use. For specific hazard statements, see Notes 7 and 12.*

## 2. Referenced Documents

### 2.1 ASTM Standards:

D 56 Test Method for Flash Point by Tag Closed Tester<sup>2</sup>

D 93 Test Methods for Flash Point by Pensky-Martens Closed Tester<sup>2</sup>

<sup>1</sup> These test methods are under the jurisdiction of ASTM Committee D-1 on Paint and Related Coatings and Materials and are the direct responsibility of Subcommittee D01.22 on Health and Safety.

Current edition approved Dec. 29, 1989. Published February 1990. Originally published as D 3278 - 73. Last previous edition D 3278 - 82<sup>\epsilon</sup>1.

<sup>2</sup> *Annual Book of ASTM Standards*, Vols 05.01 and 06.03.

D 850 Test Method for Distillation of Industrial Aromatic Hydrocarbons and Related Materials<sup>3</sup>

D 1015 Test Method for Freezing Points of High-Purity Hydrocarbons<sup>2</sup>

D 1078 Test Method for Distillation Range of Volatile Organic Liquids<sup>3</sup>

### 2.2 ISO Standards:<sup>4</sup>

ISO 3679 Paints, varnishes, petroleum and related products—Determination of flash point—Rapid equilibrium method

ISO 3680 Paints, varnishes, petroleum and related products—Flash/no flash test—Rapid equilibrium method

## 3. Terminology

### 3.1 Definitions:

3.1.1 *flash point*—the lowest temperature, corrected to a pressure of 760 mm Hg (101.3 kPa, 1013 mbar), at which application of an ignition source causes the vapor of the specimen to ignite under specified conditions of test.

## 4. Summary of Test Methods

4.1 By means of a syringe, 2 mL of the sample is introduced through a leakproof entry port into the tightly closed Setaflash Tester or directly into the cup that has been brought to the required test temperature. As a flash/no flash test, the expected flash point temperature may be a specification or other operating requirement. After 1 min, a test flame is applied inside the cup and note is taken whether or not the test specimen flashes. A fresh specimen must be used if a repeat test is necessary.

4.2 For a finite flash point measurement, the temperature is sequentially increased through the anticipated range, the test flame being applied at 9°F (5°C) intervals until a flash is observed. A true determination is then made using a fresh specimen, starting the test at the temperature of the last interval before the flash point of the material and making tests at increasing 1°F (0.5°C) intervals.

## 5. Significance and Use

5.1 Flash point is one of the properties used to define the flammability of a liquid. It is used to classify liquids according to their flammability by governmental regulatory agencies. It may also be used to determine the presence of impurities or contaminants in a given liquid, such as the presence of residual solvents in solvent-refined drying oils.

<sup>3</sup> *Annual Book of ASTM Standards*, Vol 06.03.

<sup>4</sup> Available from American National Standards Institute, 1430 Broadway, New York, NY 10018.

## 6. Apparatus

6.1 *Setaflash Tester*,<sup>5</sup> shown in Fig. A1.1 and described in Annex A1.

6.2 *Thermometers*,<sup>6</sup> low, medium, high temperature Setaflash. Test to determine that the scale error does not exceed 0.5°F (0.25°C). The use of a magnifying lens assists in making temperature observations.

6.3 *Glass Syringe*, 2 ± 0.1-mL capacity at 77°F (25°C), to provide a means of taking a uniform specimen. Check the capacity by discharging water into a weighing bottle and weighing. Adjust plunger if necessary. A disposable syringe of equal precision may be used.

6.4 *Aluminum Cooling Block*<sup>7</sup> (describing in Annex A2), that fits snugly within the test cup used for rapid cooling of the sample cup.

6.5 *Barometer*.

## 7. Reagents and Materials

7.1 *p-Xylene*,<sup>8</sup> reference standard.

7.2 *n-Butanol*,<sup>9</sup> reference standard.

7.3 *Cooling Mixtures* of ice and water or solid CO<sub>2</sub> (dry ice) and acetone.

7.4 *Liquified Petroleum Gas*.

7.5 *Heat Transfer Paste*.<sup>10</sup>

## 8. Sampling

8.1 The specimen size for each test is 2 mL. Obtain at least a 25-mL sample from the bulk source and store in a nearly full, tightly closed, clean glass container or in other container suitable for the type of liquid being sampled.

NOTE 6: **Caution**—Erroneously high flash points may be obtained if precautions are not taken to avoid loss of volatile material. Do not open sample containers unnecessarily and do not transfer the specimen to the cup unless the temperature of the specimen is at least 20°F (10°C) below the expected flash point. Discard samples in leaky containers.

NOTE 7: **Precaution**—Do not store samples in plastic bottles (polyethylene, polypropylene, etc.), as volatile material may diffuse through the walls.

## 9. Preparation of Apparatus

9.1 Prior to initial use or after removal of the thermometer, insert the thermometer into its pocket (see Fig. A1.1) with a good heat transfer paste.

9.2 To help in making the necessary settings during a test, before the initial use determine the relationship between the temperature control dial and thermometer readings at intervals not over 9°F (5°C) throughout the scale range of the heater.

9.3 Place the tester in a subdued light and in a position

not exposed to disturbing drafts. Provide a black-coated shield, if necessary.

9.4 Read the manufacturer's operating and maintenance instructions on the care and servicing of the tester. Observe the specific suggestions regarding the operation of the various controls.

9.5 Check the accuracy of the tester by duplicate determination of the flash point of the *p*-xylene reference standard (Annex A3). The mean of the results should be 81 ± 1.5°F (27.2 ± 0.8°C). An additional reference standard, *n*-butanol (Annex A3), may be used to check the accuracy at approximately the temperature specified by U.S. regulatory agencies in defining flammable liquids. The mean of duplicates should be 98 ± 1.5°F (36.7 ± 0.8°C). If not, remove the thermometer and observe whether sufficient heat transfer paste surrounds the thermometer to provide good heat transfer from the cup to the thermometer.

## TEST METHOD A—FLASH/NO FLASH

### 10. Procedure—Ambient to 230°F (110°C)

10.1 Inspect the inside of the test cup, lid, and shutter mechanism for cleanliness and freedom from contamination. Use an absorbent tissue to wipe clean, if necessary. Lock the cover lid tightly in place.

10.2 Switch the heater on, if not already at stand-by. To rapidly approach the specification flash temperature of the material under test, turn the heater dial fully clockwise (Note 8) causing the heater signal (red) light to glow. When the thermometer indicates a temperature of about 5°F (3°C) below the specification or target flash-point temperature, reduce the heat input to the test cup by slowly turning the heater control dial counter clockwise until the signal light goes out (Note 9).

NOTE 8—When a desired temperature is dialed on the controller, the elapsed time to reach this temperature may be greater than if the controller is turned "full on," but less attention is required.

NOTE 9—The test cup temperature is stable when the signal light slowly cycles on and off.

10.3 Determine the barometric pressure to determine the corrected specification temperature at that barometric pressure (see 15.1).

10.4 After the test-cup temperature has stabilized at the specification or target flash point, charge the syringe with the sample being tested and insert the tip of the syringe into the filling orifice (Fig. A1.2), taking care not to lose any material. Discharge the specimen into the test cup by completely depressing the syringe plunger, then remove the syringe. If the material has a viscosity greater than 45 SUS at 100°F (38°C) or equivalent of 9.5 cSt at 77°F (25°C), raise the lid and discharge the contents of the syringe directly into the cup. Immediately close the lid tightly.

10.5 Set the 1-min timing device. In the meantime, open the gas control valve and light the pilot and test flames. Adjust the test flame size with the pinch valve to match the size of the 5/32-in. (4-mm) diameter flame gate.

10.6 After 1 min has elapsed, observe the temperature. If at the specification temperature (accounting for the differences of the barometer reading from 760 mm), apply the test flame by slowly and uniformly opening the slide fully and closing completely over a period of approximately 2 1/2 s

<sup>5</sup> Closed-cup flash point testers and their accessories meeting the requirements of the unit shown in Fig. A1.1 are available from ERDCO Engineering Corp., 721 Custer Ave., Evanston, IL 60202 or Stanhope-Seta Ltd., Park Close Englefield Green, Engham, Surrey, TW20 OXD, England.

<sup>6</sup> Thermometers may be obtained from the suppliers of the Setaflash Tester.

<sup>7</sup> Cooling blocks may be obtained from ERDCO Engineering Corp.

<sup>8</sup> *p*-Xylene is available as "Flash Point Creek Fluid" from Special Products Div., Chemical Dept., Phillips Petroleum Co., Borger, TX 25303.

<sup>9</sup> *n*-Butanol may be obtained from chemical supply companies.

<sup>10</sup> Heat transfer paste is available from the suppliers of the Setaflash Tester. No. 340 Silicone is available from Dow Corning Corp., 2030 Willard H. Dow Center, Midland, MI 48674. G641 Heat Transfer Compound is available from General Electric Co., Products Div., 12 Corporate Woods Blvd., Albany, NY 12211.

(Note 10), watching for a flash (Note 11) while the flame is inserted.

NOTE 10—When inserted, the nozzle of the ignition device should intersect the plane of the underside of the cover (see A1.1).

NOTE 11—The material is considered to have flashed only if a comparatively large blue flame appears and propagates itself over the surface of the liquid. Occasionally, particularly near the actual flash-point temperature, application of the test flame may give rise to a halo; this effect should be ignored.

10.7 Turn off the test and pilot flame. Clean the apparatus in preparation for the next test.

### 11. Procedure—32°F (0°C) to Ambient

11.1 If the specification or target flash point is at or below ambient temperature, cool the sample to 10 to 20°F (5 to 10°C) below that point by some convenient means.

11.2 Cool the tester to approximately the temperature of the sample by inserting the cooling block (Fig. A2.1) filled with a cooling mixture (Notes 12 and 13) into the sample well. Dry the cup with a paper tissue to remove any collected moisture prior to adding the specimen using a precooled syringe.

NOTE 12: **Precaution**—Be careful in handling the cooling mixture and cooling block; wear gloves and goggles. Mixtures such as dry ice and acetone can produce severe frost bite.

NOTE 13: **Caution**—Be careful when inserting the cooling block into the tester cup to prevent damage to the cup.

11.3 Introduce the specimen as in 10.4. Allow the temperature to rise under ambient conditions or increase the temperature of the cup by rotating the heater controller clockwise slowly until the specification temperature adjusted for barometric pressure is reached. Determine whether the material flashes as in 10.5 and 10.6.

11.4 Turn off the test and pilot flames. Clean the apparatus.

### TEST METHOD B—FINITE FLASH POINT

#### 12. Procedure—Ambient to 230°F (110°C)

##### 12.1 *Preliminary or Trial Test:*

12.1.1 Follow steps 10.1 to 10.5, omitting the barometric reading and using an estimated finite flash point instead of specification flash-point temperature.

12.1.2 After 1 min has elapsed, observe the temperature. Apply the test flame by slowly and uniformly opening the slide fully and closing completely over a period of 2½ s (Note 10), watching for a flash (Note 11) while the flame is inserted.

12.2 If a flash is observed, proceed as in 12.3. If no flash is observed, proceed as in 12.4.

12.3 Using a temperature 9°F (5°C) lower than the temperature observed in 12.1.2, repeat 12.1 (Note 4). If a flash is still observed, repeat at 9°F lower intervals until no flash is observed.

NOTE 14—Never make a repeat test on the same specimen. Always take a fresh portion for each test.

12.3.1 After establishing the approximate flash point, repeat 12.1 with a new specimen, but stabilizing the test temperature at which no flash occurred previously. Observe if a flash occurs at this temperature. If not, increase the temperature by making a small adjustment to the tempera-

ture controller so that an increase of 1°F (0.5°C) occurs within 1 min. Test for a flash at each 1°F interval, recording the temperature at which the flash actually occurs. Record the barometric pressure. Clean the tester.

12.3.1.1 Repeat 12.3.1 with a new specimen. Calculate the corrected mean temperature in accordance with 15.2. Turn off pilot and test flames and clean the tester.

12.4 Using a test temperature 9°F (5°C) higher than the temperature observed in 12.2, repeat 12.1 (Note 14). If no flash is observed, repeat at 9°F higher intervals until a flash is observed.

12.4.1 After establishing the approximate flash point (12.4) with new specimens, make two determinations of the flash point in accordance with 12.3.1 and calculate the corrected mean temperature in accordance with 15.2.

#### 13. Procedure—32°F (0°C) to Ambient Temperature

##### 13.1 *Preliminary or Trial Test:*

13.1.1 Cool the sample to 5 to 10°F (3 to 5°C) below the expected flash point.

13.1.2 Cool the tester to approximately the temperature of the sample by inserting the cooling block filled with a cooling medium into the sample well. (**Precaution**—See Notes 12 and 13.)

13.1.3 Introduce the specimen using a precooled syringe as in 10.4. Set the 1-min timing device. After 1 min observe the temperature, then apply the test flame by slowly and uniformly opening the slide fully and closing completely over a period of 2½ s, watching for a flash (Note 11) while the flame is inserted. Record the temperature.

13.2 If a flash is observed, proceed as in 13.3. If no flash is observed, proceed as in 13.4.

13.3 Take a new specimen and recool the sample cup to 9°F (5°C) below the previous temperature (13.1.3). After 1 min, check for a flash as in 13.1.3. If the material flashes, repeat at 9°F lower intervals until no flash is observed.

13.3.1 After establishing the approximate flash point, repeat 13.1.1 and 13.1.3 with a new specimen but stabilizing the test temperature at which no flash occurred previously. Observe if a flash occurs at this temperature. If not, increase the temperature by making a small adjustment to the temperature controller so that an increase of 1°F (0.5°C) occurs within 1 min. Test for a flash at each 1°F interval, recording the temperature at which the flash actually occurs. Record the barometric pressure.

13.3.1.1 Repeat 13.3.1 with a new specimen. Calculate the corrected mean in accordance with 15.2. Turn off pilot and test flames and clean the tester.

13.4 Using a test temperature 9°F (5°C) higher than the temperature observed in 13.1.3, repeat 13.1.3 (Note 14). If no flash is observed, repeat at 9°F higher intervals until a flash is observed.

13.4.1 After establishing the approximate flash point (13.4), make the determinations of the flash point in accordance with 13.3 and calculate the corrected mean in accordance with 15.2.

#### 14. Clean-up of Apparatus and Preparation for Next Test

14.1 Unlock the lid assembly of the tester and raise to the hinge stop. Soak up liquid with an absorbent paper tissue and wipe dry. Clean the underside of the lid and filling

orifice. A pipe cleaner may be of assistance in cleaning the orifice.

14.2 If the material is a viscous liquid or contains dispersed solids, after soaking up most of the specimen add a small amount of a solvent suitable for the sample to the cup. Then soak up the solvent and wipe clean the interior surfaces of the cup with an absorbent tissue paper.

NOTE 15—If necessary to remove residual high boiling solvent residues, moisten tissue with acetone and wipe dry.

NOTE 16—If any further cleaning is necessary, remove the lid and shutter assembly. Disconnect the silicone rubber hose and slide the lid assembly to the right to remove. If warm, handle carefully.

14.3 After the cup has been cleaned, its temperature may be rapidly increased to some stand-by value by turning the temperature control dial to an appropriate point.

NOTE 17—It is convenient to hold the test cup at some stand-by temperature (depending on planned usage) to conserve time in bringing the cup within the test temperature range. The cup temperature may be quickly lowered by inserting the aluminum cooling block filled with an appropriate cooling mixture into the cup.

14.4 The syringe is easily cleaned by filling it several times with acetone or other compatible solvent, discharging the solvent each time, and allowing the syringe to air dry with the plunger removed. Replace the plunger, and pump several times to displace any solvent vapor with air.

### 15. Correction for Barometric Pressure

15.1 Determine the corrected specification flash point to be used in Test Method A by the following equations:

$$\begin{aligned} F &= S - 0.06 (760 - P) \\ C &= T - 0.03 (760 - P) \\ F &= S - 0.42 (101.3 - B) \\ C &= T - 0.23 (101.3 - B) \end{aligned}$$

where:

$F$  = flash point to be observed to obtain the specification flash point at standard pressure, °F (°C),

$S(T)$  = specification flash point, °F (°C), and

$P(B)$  = ambient barometric pressure, mm Hg (kPa).

NOTE 18—The barometric pressure used in this calculation must be the ambient pressure for the laboratory at the time of test. Many aneroid barometers, such as those used at weather stations and airports, are precorrected to give sea-level readings. These must not be used.

15.2 When the barometric pressure in Test Method B differs from 760 mm Hg, correct the flash point temperature,  $A$ , by means of the following equations:

$$\begin{aligned} A &= F + 0.06 (760 - P) \\ &= C + 0.03 (760 - P) \\ &= F + 0.42 (101.3 - B) \\ &= C + 0.23 (101.3 - B) \end{aligned}$$

where:

$F(C)$  = observed flash point, °F (°C), and

$P(B)$  = ambient barometric pressure, mm Hg (kPa).

### 16. Report

16.1 When using the flash/no flash method, report whether or not the sample flashed at the required flash point

and that Test Method A was used.

16.2 If an actual flash point was determined, report the mean of duplicate determinations to the nearest 1°F (0.5°C), provided the difference between the values does not exceed 2°F (1°C) and that Test Method B was used.

### 17. Precision<sup>11</sup> and Bias

17.1 On the basis of an interlaboratory study of Test Method B in which one operator in each of five laboratories made two determinations on two different days on four solvents, three resins and two paints of different flash points, the within-laboratory and between-laboratory standard deviations were found to be:

Materials	Standard Deviation	
	Within-Laboratory	Between-Laboratory
Solvents (viscosity below 45 SUS at 100°F), °F	0.98	1.55
Resins and Paints (viscosity above 45 SUS at 100°F), °F	1.89	2.41

Based on these standard deviations, the following criteria should be used for judging the acceptability of results at the 95 % confidence level:

17.2 *Liquids at or Below 45 SUS at 100°F or Equivalent Viscosity:*

17.2.1 *Repeatability*—Two results, each the mean of two determinations, obtained by the same operator on different days should be considered suspect if they differ by more than 3°F (1.7°C).

17.2.2 *Reproducibility*—Two results, each the mean of two measurements, obtained by different laboratories, should be considered suspect if they differ by more than 6°F (3.3°C).

17.3 *Viscous Liquid Above 45 SUS at 100°F or Liquids With Dispersed Solids:*

17.3.1 *Repeatability*—Two results, each the mean of two determinations, obtained by the same operator on different days should be considered suspect if they differ by more than 6°F (3.3°C).

17.3.2 *Reproducibility*—Two results, each the mean of two measurements, obtained by different laboratories should be considered suspect if they differ by more than 9°F (5°C).

17.4 A study to determine the precision for materials with a viscosity greater than 150 St has not been made.

17.5 The precision for liquid peroxides has not been determined, but the precision of liquid peroxides should be similar to that of other liquids.

17.6 *Bias*—No estimate of the bias of flash-point tests can be determined as no absolute values are available. In addition, the results are equipment and method dependent.

### 18. Keywords

18.1 flash point; Setaflash Closed-Cup; organic peroxides; flash/no flash; *p*-xylene; *n*-butanol

<sup>11</sup> Supporting data are available from ASTM Headquarters. Request RR:D01-1000. These data are also reported in the *Journal of Paint Technology*, Vol 45, No. 581, p. 44.

**ANNEXES**

**(Mandatory Information)**

**A1. APPARATUS SPECIFICATIONS**

A1.1 A typical apparatus is shown in Fig. A1.1. Electrical heaters are fastened to the cup in a way as to provide for efficient transfer of heat. The tester includes a variable heater control device with a scaled dial and a visible signal to indicate when energy is or is not being applied. Energy may be supplied from a 100 to 250 V 50/60 Hz (for stationary use) or by a 12-V d-c battery service (for field use). An adjustable test flame and a pilot flame to maintain the test flame are provided. These flames may be fueled by piped gas service (fixed location) or by a self-contained tank of

liquefied petroleum gas (7.4) (for portability). A test flame measuring  $\frac{5}{32}$  in. (4 mm) in diameter may be checked against a gage ring on the surface of the tester. Never recharge the gas tank with the pilot or test flames lighted, nor in the vicinity of other naked flames. A 1-min audible signal is a desirable accessory. The cover is fitted with an opening slide device capable of inserting the ignition flame into the well when the slide is open. When inserted the nozzle of the ignition device shall intersect the plane of the underside of the cover.

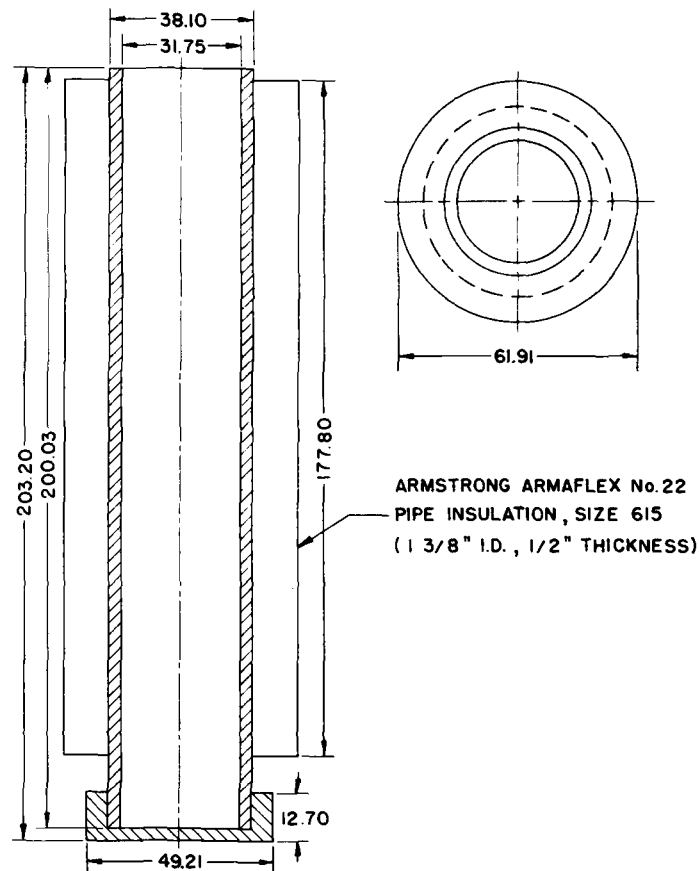

NOTE—All dimensions are in millimetres.

**FIG. A1.1 Setaflash Unit**

A2. COOLING BLOCK

A2.1 The cooling block with dimensions as shown in Fig. A2.1 is made of aluminum and covered with pipe insulation.

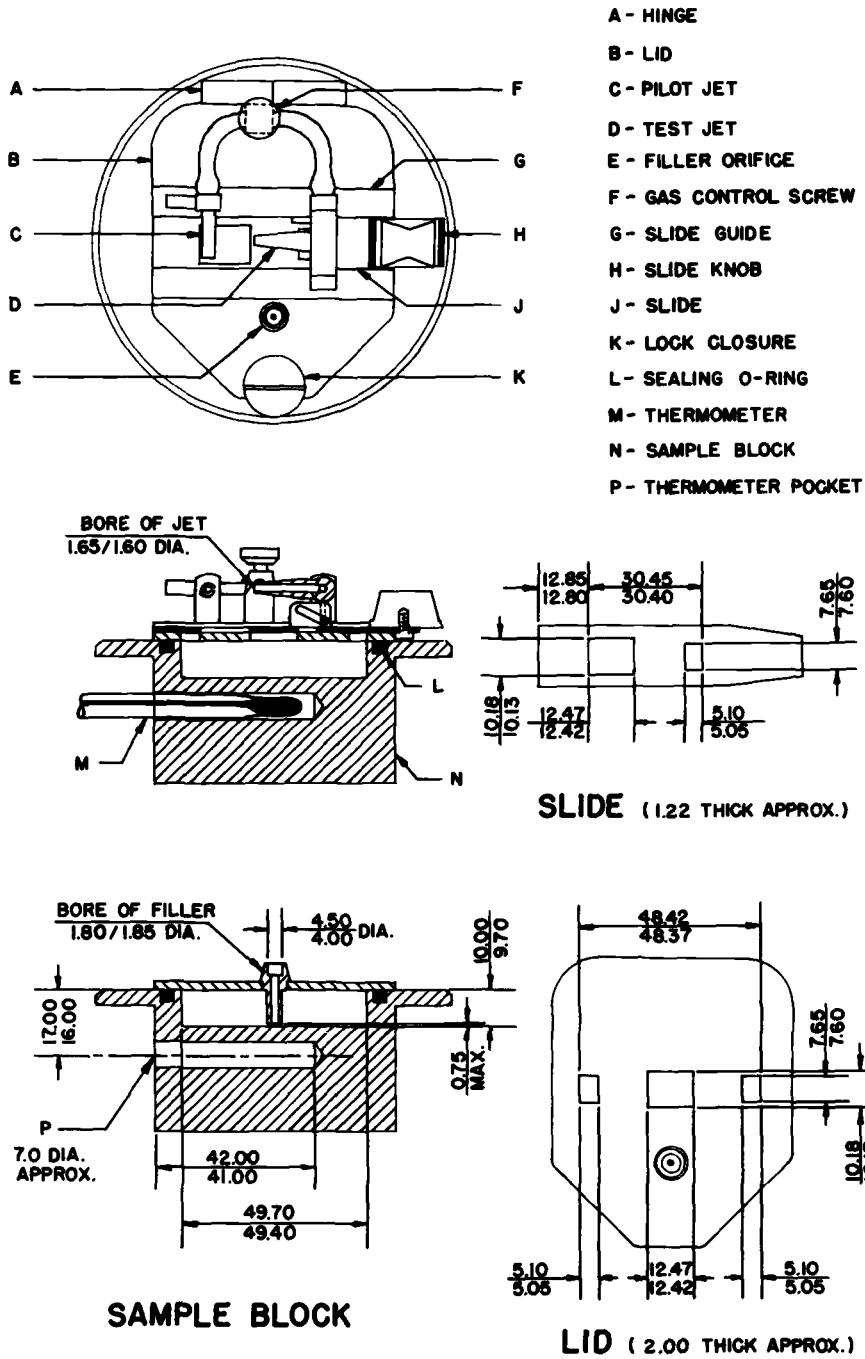

FIG. A2.1 Cooling Block

### A3. SPECIFICATIONS FOR *p*-XYLENE AND *n*-BUTANOL REFERENCE STANDARDS

#### A3.1 *p*-Xylene

A3.1.1 *Specific Gravity, 60/60°F (15.56/15.56°C) Range*—0.860 minimum, 0.866 maximum.

A3.1.2 *Boiling Range*—2°C maximum from start to dry point when tested in accordance with Test Method D 850 or Test Method D 1078. The range shall include the boiling point of pure *p*-xylene, which is 138.35°C.

A3.1.3 *Freezing Point*—11.23°C minimum (95 % molal purity) as determined in accordance with Test Method D 1015.

#### A3.2 *n*-Butanol

A3.2.1 *Specific Gravity, 20/4°C Range*—0.809 minimum, 0.810 maximum.

A3.2.2 *Boiling Range*—1.5°C maximum from start to dry time determined in accordance with Test Method D 1078. The range shall include the boiling point of pure *n*-butanol, which is 117.7°C.

A3.2.3 *Melting Point Range*—−90°C minimum, −89.5°C maximum.

A3.2.4 *Refractive Index *n* 20/D Range*—1.3985 minimum, 1.3993 maximum.

A3.2.5 *Purity by Gas Chromatography*—99.5 % minimum.

### A4. TESTING HIGH VISCOSITY LIQUIDS

A4.1 High-viscosity materials may be added to the cup by the following procedure:

A4.1.1 *Procedure*—Back load a 5 or 10-mL syringe with the sample to be tested and extrude 4 mL into the cup. Spread the specimen as evenly as possible over the bottom of the cup.

A4.1.2 If the sample cannot be loaded into a syringe and extruded, use other means of adding the specimen to the cup

provided a presentative 4-mL specimen can be put into the cup. A spoon of appropriate size is convenient. Push the material from the spoon into the cup.

A4.1.3 If the test specimen does not seal off the bottom of the filling orifice, seal the orifice from the top by suitable means.

A4.2 Using Test Method A (Section 10 or 11), determine whether or not the material flashes or, using Test Method B (Section 12 or 13), determine the flash point of the specimen.

### A5. TESTING ORGANIC PEROXIDES

A5.1 Organic peroxides may be tested by Test Methods A or B with minor modifications that take into account the hazard potential of these compounds.

A5.1.1 The tester should be located behind a transparent safety shield, and fire resistant gloves should be worn.

A5.1.2 The procedure in 10.1 is followed with the exception that the cover lid is not locked in place. Rather, a spring-wire test-tube holder is clamped to the hold-down

lock on the lid to provide an extension arm about 5 in. (12.7 cm) long. A weight of approximately 100 g is hung from the end of the test tube holder. This arrangement adequately seals the test while allowing venting with a rapidly decomposing peroxide.

A5.1.3 Follow the procedures described in Test Methods A or B (Sections 10 through 14). However, when applying the test flame, grasp the handle by means of a second test tube holder, pliers, or tongs.

*The American Society for Testing and Materials takes no position respecting the validity of any patent rights asserted in connection with any item mentioned in this standard. Users of this standard are expressly advised that determination of the validity of any such patent rights, and the risk of infringement of such rights, are entirely their own responsibility.*

*This standard is subject to revision at any time by the responsible technical committee and must be reviewed every five years and if not revised, either reapproved or withdrawn. Your comments are invited either for revision of this standard or for additional standards and should be addressed to ASTM Headquarters. Your comments will receive careful consideration at a meeting of the responsible technical committee, which you may attend. If you feel that your comments have not received a fair hearing you should make your views known to the ASTM Committee on Standards, 1916 Race St., Philadelphia, PA 19103.*





## Standard Test Methods for Flash Point by Setaflash Closed Tester<sup>1</sup>

This standard is issued under the fixed designation D 3828; the number immediately following the designation indicates the year of original adoption or, in the case of revision, the year of last revision. A number in parentheses indicates the year of last reapproval. A superscript epsilon ( $\epsilon$ ) indicates an editorial change since the last revision or reapproval. This is also a standard of the Institute of Petroleum issued under the fixed designation IP 303. The final number indicates year of last revision.

*This test method was adopted as a joint ASTM-IP standard in 1979.*

*This standard has been approved for use by agencies of the Department of Defense. Consult the DoD Index of Specifications and Standards for the specific year of issue which has been adopted by the Department of Defense.*

<sup>ε1</sup> NOTE—An editorial correction was made in Section 11.5 in December 1988.

### 1. Scope

1.1 These test methods cover procedures for the determination of the flash point by a Setaflash<sup>2</sup> closed tester. The procedures may be used to determine the actual flash point temperature of a sample or whether a product will or will not flash at a specified temperature (flash/no flash).

1.2 *This standard should be used to measure and describe the properties of materials, products, or assemblies in response to heat and flame under controlled laboratory conditions and should not be used to describe or appraise the fire hazard or fire risk of materials, products, or assemblies under actual fire conditions. However, results of this test may be used as elements of a fire risk assessment which takes into account all of the factors which are pertinent to an assessment of the fire hazard of a particular end use.*

1.3 The values stated in inch-pound units are to be regarded as the standard. Temperatures are in degrees Fahrenheit and viscosity is in Centistoke units. The values in parentheses are for information only.

1.4 *This standard may involve hazardous materials, operations, and equipment. This standard does not purport to address all of the safety problems associated with its use. It is the responsibility of the user of this standard to establish appropriate safety and health practices and determine the applicability of regulatory limitations prior to use. For specific hazard statements, see Notes 9 and A1.1 and Table 1, Footnote B.*

### 2. Definition

2.1 *flash point*—the lowest temperature corrected to a pressure of 760 mm Hg (101.3 kPa, 1013 m bar) at which application of a test flame causes the vapors of a portion of the sample to ignite under specified conditions of test.

2.1.1 Occasionally, particularly near the actual flash point, the application of the test flame will cause a blue halo or an enlarged flame; this is not a flash and should be ignored.

### 3. Summary of Test Methods

3.1 *Method A—Flash/No Flash Test*—A portion of a sample is introduced by a syringe into the cup of the selected apparatus that is set and maintained at the specified temperature. After a specific time a test flame is applied and an observation made as to whether or not a flash occurred.

3.2 *Method B—Finite (or Actual) Flash Point:*

3.2.1 A portion of a sample is introduced into the cup of the selected apparatus that is maintained at the expected flash point. After a specified time a test flame is applied and the observation made whether or not a flash occurred.

3.2.2 The portion is removed from the cup, the cup cleaned, and the cup temperature adjusted 9°F (5°C) lower or higher depending on whether or not a flash occurred previously. A fresh portion is introduced and tested. This procedure is repeated until the flash point is established within 9°F (5°C).

3.2.3 The procedure is then repeated at 2°F (1°C) intervals until the flash point is determined to the nearest 2°F (1°C).

3.2.4 If improved accuracy is desired the procedure is repeated at 1°F (0.5°C) intervals until the flash point is determined to the nearest 1°F (0.5°C).

### 4. Significance and Use

4.1 Flash point measures the response of the sample to heat and flame under controlled laboratory conditions. It is only one of a number of properties that must be considered in assessing the overall flammability hazard of a material.

4.2 Flash point is used in shipping and safety regulations to define “flammable” and “combustible” materials and classify them. One should consult the particular regulation involved for precise definitions of these classes.

4.3 Flash point can indicate the possible presence of highly volatile and flammable materials in a relatively nonvolatile or nonflammable material.

<sup>1</sup> These test methods are under the jurisdiction of ASTM Committee D-2 on Petroleum Products and Lubricants and is the direct responsibility of Subcommittee D02.08 on Volatility.

Current edition approved Dec. 14, 1987. Published January 1988. Originally published as D 3828 – 79. Last previous edition D 3828 – 81.

<sup>2</sup> Setaflash is a registered trademark of Stanhope-Seta Limited. Designated RAPID TESTS FOR FLASH POINT by the Institute of Petroleum (IP-303).

**TABLE 1 Calibration of Tester**

Material	<i>p</i> -xylene <sup>A</sup> (Warning) <sup>B</sup>	<i>n</i> -butanol <sup>A</sup> (Warning) <sup>B</sup>
Specific gravity, 60/60°F (15.6/15.6°C)	0.860 to 0.866	0.810 to 0.812
Boiling range, °F (°C)	4 (2) maximum including 281.03 (138.35)	4 (2) maximum including 243.5 (117.5)
Freezing point, °F (°C)	52.2 (11.23) minimum	-130 (-90) minimum
Flash point, °F (°C) (acceptable range)	78 ± 1 (25.6 ± 0.5)	97.9 ± 1.7 (36.6 ± 0.8)

<sup>A</sup> Available as Flash Point Check Fluid from Special Products Div., Phillips Petroleum Co., Drawer O, Borgen, TX 79007.

<sup>B</sup> Warning: Handle xylene and *n*-butanol with care. Avoid inhalation; use only in a well-ventilated area. Avoid prolonged or repeated contact with skin. Keep away from flames and heat, except as necessary for the actual flash point determination.

## 5. Apparatus

5.1 *Test Cup and Cover Assembly*—The essential dimensions and requirements of the apparatus are shown in Fig. A1.1 and Table A1 of the Annex. The apparatus and accessories are described in detail in Annex A1.<sup>3</sup>

## 6. Safety Precautions

6.1 The operator must exercise and take appropriate safety precautions during the initial application of the test flame to the sample. Samples containing low-flash material may give an abnormally strong flash when the test flame is first applied.

6.2 When using the instruments at elevated temperatures, take care to keep hands away from the cup area, except for the operating handles.

## 7. Sample

7.1 Erroneously high flash points can be obtained when precautions are not taken to avoid the loss of volatile material. Do not open containers unnecessarily and make a transfer unless the sample temperature is at least 18°F (10°C) below the expected flash point. Do not use samples from leaky containers for this test.

7.2 Do not store samples in plastic (polyethylene, polypropylene, etc.) bottles since volatile material may diffuse through the walls of the bottle.

7.3 A 2 or 4-mL portion is required for each test. Obtain at least a 50-mL sample from the bulk test site and store in a clean, tightly closed container.

## 8. Preparation of Apparatus

8.1 Place the tester on a level, stable surface. Unless tests are made in a draft-free area, surround the tester on three sides with a shield for protection. Do not rely on tests made in a laboratory draft hood or near ventilators.

8.2 Read the manufacturer's instructions on the care and servicing of the instrument and for correct operation of its controls. Low temperature testing is ambient to 230°F (110°C). High temperature is 212 to 572°F (100 to 300°C).

## 9. Calibration and Standardization

9.1 Before initial use determine and plot the relationship between the temperature control dial and the thermometer readings:

9.1.1 Turn the temperature control knob (Note 1) fully counterclockwise ("0" reading). Advance the temperature control knob clockwise until the indicator light is illumi-

nated (Note 2). Advance the knob clockwise to the next numbered line. After the thermometer mercury column ceases to advance, record the dial reading and the temperature. Advance the knob clockwise to the next numbered line. After the thermometer mercury column ceases to advance, record the dial reading and the temperature. Repeat this procedure through the full range of the instrument. Plot the dial readings versus the respective temperatures.

NOTE 1—When the instrument has two temperature control knobs, set the fine control (center, small knob) at its mid-position and allow it to remain there throughout the calibration. The calibration is determined by adjusting the coarse control (larger, out knob) only.

NOTE 2—When testing at low temperatures, it will be found that the indicator light may not illuminate and the temperature may not rise until an upscale temperature control setting is reached.

9.2 Standardize the instrument using the appropriate sample from Table 1. When the average of two determinations falls within the acceptable limits the instrument is assumed to be operating properly. If the average of the two determinations does not fall within this range, check the manufacturer's operating and maintenance instructions and determine that they are being followed. In particular, be sure that the cup lid assembly makes a vapor-tight seal with the cup, the shutter provides a light-tight seal, and that adequate heat transfer paste surrounds the thermometer bulb and the immersed portion of its barrel.

## METHOD A—FLASH/NO FLASH TEST

### 10. Procedure

10.1 Determine the target flash point as follows:

(A) Target flash point, °C =  $S_c - 0.25(101.3 - A)$

(B) Target flash point, °C =  $S_c - 0.03(760 - B)$

(C) Target flash point, °F =  $S_f - 0.06(760 - B)$

where:

$S_c$  = specification, or uncorrected target, flash point, °C,  
 $S_f$  = specification, or uncorrected target, flash point, °F,  
 and

$B$  = ambient barometric pressure, mm Hg, and

$A$  = ambient barometric pressure, kPa.

NOTE 3—The barometric pressure used in this calculation must be the ambient pressure for the laboratory at the time of test. Many aneroid barometers, such as those used at weather stations and airports, are precorrected to give sea level readings; these must not be used.

10.2 Select the proper instrument, as recommended by the manufacturer, for the target flash point (8.2).

10.2.1 Inspect the inside of the sample cup, lid, and shutter mechanism for cleanliness and freedom from contamination. Use an absorbent paper tissue to wipe clean, when necessary. Put cover in place and lock securely. The

<sup>3</sup> Closed cup flash point testers and their accessories meeting these requirements are available from ERDCO Engineering Corp., 721 Custer Ave., Evanston, IL 60202, or Stanhope-Seta Ltd., Park Close, Englefield Green, Egham, Surrey, England TW20 OXD.

filling orifice can be conveniently cleaned with a pipe cleaner.

**10.3 For Target Temperature Above Ambient**—Switch the instrument on and turn the coarse temperature control knob fully clockwise (full on) causing the indicator light to illuminate (Note 4). When the thermometer indicates a temperature about 5°F (3°C) below the target (or specification) temperature, reduce the heat input to the sample cup by turning the coarse temperature control knob counterclockwise to the desired control point (10.1). When the indicator light slowly cycles on and off read the temperature on the thermometer. When necessary, adjust the fine (center) temperature control knob to obtain the desired test (target) temperature. When the test temperature is reached and the indicator lamp slowly cycles on and off, prepare to introduce the portion of the sample.

**NOTE 4**—The target temperature may be attained by originally turning the coarse temperature control knob to the proper setting (9.1) for the temperature desired rather than to the maximum setting (full on). The elapsed time to reach the temperature will be greater, except for maximum temperature; however, less attention will be required during the intervening period.

**10.4** Charge the syringe with a 2-mL portion of the sample to be tested; transfer the syringe to the filling orifice, taking care not to lose any sample; discharge the test portion into the cup by fully depressing the syringe plunger; remove the syringe.

**NOTE 5**—When testing at high temperatures repeat this portion of the procedure charging the sample cup with the required total of 4 mL of sample. Alternatively, use the 5-mL syringe preset to deliver 4 mL and charge all of the portion at one time. Refer to Annex A1.5.

**10.5** Set the timer by rotating its knob clockwise to its stop. Light a match or other source of flame. Slowly open the gas control valve and light the pilot and test flames. Adjust the test flame with the pinch valve to conform to the size of the  $\frac{5}{32}$ -in. (4-mm) gage.

**10.5.1** After the time signal indicates the portion is at test temperature, apply the test flame by slowly and uniformly opening the shutter and losing it completely over a period of approximate 2½ s (Note 6). Watch closely for a flash at the cup openings.

**NOTE 6**—Never apply the test flame to the portion more than once. A fresh portion of the sample must be used for each test.

**10.5.2** The sample is deemed to have flashed when a large flame appears and instantaneously propagates itself over the surface of the sample (2.1.1).

**10.6** Record the test result as flash (or no flash) and the test temperature. It is also recommended the instrument used and the appropriate ASTM or IP standard number be recorded.

**10.7** Turn off the pilot and test flames using the gas control valve. Remove the sample and clean the instrument. It may be necessary to allow the cup temperature to fall to a safe level before cleaning.

**10.8 For Target Temperature Below Ambient**—The instrument power switch is to be in the off position. Fill the refrigerant-charged cooling block with a suitable material (Note 7). Raise the lid and shutter assembly, and position the base of the block in the sample cup, being careful not to damage or mar the cup. When the thermometer reads

approximately 10 to 20°F (5 to 10°C) (**Caution**—See Note 8) below the target temperature, remove the cooling block and quickly dry the cup with a paper tissue to remove any moisture. Immediately close the lid and shutter assembly and secure. Prepare to introduce the portion of the sample using the syringe, both of which have been precooled to a temperature 10 to 20°F (5 to 10°C) below the target temperature.

**NOTE 7**—When the target or specification temperature is not less than 40°F (5°C) crushed ice and water may be used as a charging (cooling) fluid. If below 40°F (5°C) a suitable charging (cooling) fluid is solid carbon dioxide (dry ice) and acetone (**Warning**—See Note 9). If the refrigerant-charged cooling module is unavailable, refer to the manufacturer's instruction manual for alternative methods of cooling.

**NOTE 8**—**Caution**—Do not cool the sample block below -36°F (-38°C), the freezing point of mercury.

**NOTE 9**—**Warning**—Acetone is extremely flammable. **Precaution**—Keep away from heat, sparks, and flames and keep container closed when not actually pouring acetone. Use only in a well-ventilated area. Avoid inhalation and contact with the eyes or skin. Dry ice must not contact the eyes or skin. Use cloth or leather gloves, goggles or safety shield, and keep dry ice in a canvas bag, especially when cracking.

**10.9** Follow the procedure in 10.4 to 10.7.

**NOTE 10**—For target temperatures below ambient do not set the timer. Adjust the test flame and allow the temperature to rise under ambient conditions until the target temperature is reached. Immediately apply the test flame as detailed. To reduce time for running the test, as the temperature nears ambient, increase the temperature of the cup by rotating the tester controller clockwise slowly until the target temperature is reached.

## METHOD B—FINITE OR ACTUAL FLASH POINT DETERMINATION

### 11. Procedure

**11.1** Select the proper instrument, as recommended by the manufacturer, for the expected flash point (8.2)

**11.1.1** Inspect the inside of the sample cup, lid, and shutter mechanism for cleanliness and freedom from contamination. Use an absorbent paper tissue to wipe clean, if necessary. Put cover in place and lock securely. The filling orifice can be conveniently cleaned with a pipe cleaner.

**11.2 For Tests Where the Expected Flash Point is Above Ambient**—Turn the coarse temperature control knob fully clockwise (full on) causing the indicator light to illuminate. When the thermometer reaches a temperature 5°F (3°C) below the estimated flash point, turn the coarse temperature knob counterclockwise to the dial reading representing the estimated flash point temperature as shown on the calibration curve (9.1). When the indicator light slowly cycles on and off, read the temperature on the thermometer. If necessary, adjust the fine temperatures control knob to obtain the exact desired temperature.

**11.3** Charge the syringe with a 2-mL portion of the sample to be tested; transfer the syringe to the filling orifice, taking care not to lose any sample; discharge the test portion into the cup by fully depressing the syringe plunger; remove the syringe (Note 5).

**TABLE 2 Repeatability and Reproducibility**

Temperature, °F (°C)	Repeatability, °F (°C)	Reproducibility, °F (°C)
68 (20)	0.9 (0.5)	2.7 (1.5)
158 (70)	0.9 (0.5)	5.4 (3.0)
200 (93)	2.3 (1.3)	8.8 (4.9)
300 (149)	3.6 (2.0)	13.5 (7.5)
400 (204)	4.7 (2.6)	18.0 (10.0)
500 (260)	5.9 (3.3)	22.3 (12.4)

11.3.1 Set the timer by rotating its knob clockwise to its stop. Light the match or other source of flame. Slowly open the gas control valve and ignite the pilot and test flames. Adjust the test flame with the pinch valve to conform to the size of the 5/32-in. (4-mm) gage.

11.3.2 After the audible time signal indicates the portion is at test temperature, apply the test flame by slowly and uniformly opening the shutter and then closing it completely over a period of approximately 2½ s. Watch closely for a flash at the cup opening.

11.3.2.1 The sample is deemed to have flashed only when a large flame appears and instantaneously propagates itself over the surface of the sample (2.1.1).

11.3.3 Turn off the pilot and test flames using the gas control valve. When the cup temperature falls to a safe level, remove the sample and clean the instrument.

11.4 If a flash was observed in 11.3.2 repeat the procedure given in 11.2 and 11.3 testing a new portion at a temperature 9°F (5°C) below that at which the flash was observed.

11.4.1 If necessary, repeat 11.4 lowering the temperature 9°F (5°C) each time, until no flash is observed (Note 6).

11.4.2 Proceed to 11.6.

11.5 When no flash was observed in 11.3.2 repeat the procedure given in 11.2 and 11.3 testing a fresh portion at a temperature 9°F (5°C) higher each time until a flash is observed (Note 6).

11.6 Having established a flash within two temperatures 9°F (5°C) apart, repeat the procedure at 2°F (1°C) intervals from the lower of the two temperatures until a flash is observed (Note 6). Record the temperature of the test when this flash occurs as the flash point, allowing for any known thermometer correction. Record the barometric pressure (Note 3).

11.7 The flash point determined in 11.6 will be to the nearest 2°F (1°C). If improved accuracy is desired (that is, to the nearest 1°F (0.5°C)) test a fresh portion at a temperature 1°F (0.5°C) below that at which the flash was observed in 11.6. If no flash is observed, the temperature recorded in 11.6 is the flash point to the nearest 1°F (0.5°C). If a flash is observed at the lower temperature (11.7), record this latter temperature as the flash point.

11.8 Turn off the pilot and test flames using the gas control valve. When the cup temperature falls to a safe level, remove the sample and clean the instrument.

11.9 *For Expected Flash Points Below Ambient*—The instrument power switch is to be in off position. Fill the refrigerant-charged cooling block with a suitable material (Note 7). Raise the lid and shutter assembly, and position the base of the block in the sample cup, being careful not to dent or mar the cup. When the thermometer reaches a temperature 10 to 20°F (5 to 10°C) (Caution—See Note 8) below the

expected flash point, remove the cooling block and quickly dry the cup with a paper tissue to remove any moisture. Immediately close the lid and shutter assembly and secure. Prepare to introduce the portion using the syringe, both of which have been precooled to a temperature 10 to 20°F (5 to 10°C) below the expected temperature.

11.10 Follow the procedure in 11.3 to 11.8.

NOTE 11—For expected flash points below ambient do not set the timing device. Adjust the test flame. Allow the temperature to rise, under ambient conditions, until the temperature reaches 9°F (5°C) below the expected flash point. Immediately apply the test flame.

## 12. Calculation

12.1 If it is desired to correct the observed finite flash point for the effect of barometric pressure, proceed as follows:

12.1.1 Observe and record the ambient barometric pressure (Note 3) at the time of the test. If the pressure differs from 760 mm Hg (101.3 kPa) correct the flash point as follows:

$$(A) \text{ Corrected flash point } (^{\circ}\text{C}) = C + 0.25(101.3 - A)$$

$$(B) \text{ Corrected flash point } (^{\circ}\text{F}) = F + 0.06(760 - B)$$

$$(C) \text{ Corrected flash point } (^{\circ}\text{C}) = C + 0.03(760 - B)$$

where:

$F$  = observed flash point, °F,

$C$  = observed flash point, °C,

$B$  = ambient barometric pressure, mm Hg, and

$A$  = ambient barometric pressure, kPa.

## 13. Report

13.1 When using Method A (flash/no flash), report flash (or no flash) at the target temperature (report temperature) and that Method A was used.

13.2 When a finite flash point was determined (Method B), report it to the nearest 2°F (1°C) or, if 11.7 was used, to the nearest 1°F (0.5°C) and that Method B was used.

## 14. Precision and Bias<sup>4</sup>

14.1 *Precision*—The precision of this test method as determined by statistical examination of interlaboratory results is as follows:

14.1.1 *Repeatability*—The difference between the two test results, obtained by the same operator with the same apparatus under constant operating conditions on identical test material, would, in the long run, in the normal and correct operation of this test method, exceed the values shown in Table 2 only in 1 case in 20.

14.1.2 *Reproducibility*—The difference between two single and independent results obtained by different operators working in different laboratories on identical test material, would, in the long run, in the normal and correct operation of this test method, exceed the values shown in Table 2 only in 1 case in 20.

14.2 The above have been calculated from the following equations which were obtained by statistical examination of interlaboratory test results. Values below 158°F (70°C) were first published in 1977.

<sup>4</sup> Supporting data are available from ASTM Headquarters. Request RR:D02:1214.

14.2.1:

Range	Repeatability
68 to 158°F (20 to 70°C)	0.9°F (0.5°C)
above 158°F (70°C)	0.0117 M°F (0.022 M <sup>0.9</sup> °C)

where: *M* = mean of two results.

14.2.2:

Range

68 to 158°F (20 to 70°C)  
above 158°F (70°C)

Reproducibility

0.03 (*M* + 22)°F [0.03 (*M* + 29)°C]  
0.045 M°F (0.083 M<sup>0.9</sup> °C)

where: *M* = mean of the two results.

14.3 *Bias*—The procedure in this test method has no bias because flash point can be defined only in terms of a test method.

ANNEX

(Mandatory Information)

A1. FLASH TEST APPARATUS

A1.1 *Cup Unit* consisting of an aluminum alloy or nonrusting metal block of suitable conductivity with a cylindrical depression, or sample cup, over which is fitted a cover. A thermometer is inserted in the block.

A1.1.1 The cover is fitted with an opening slide and a device capable of inserting an ignition flame (diameter 4 ± 0.5 mm) into the well when the slide is open. When inserted, the nozzle of the ignition device shall intersect the plane of the underside of the cover. The cover is also provided with

an orifice extending into the sample well for insertion of the test sample and also a suitable clamping device for securing the cover tightly to the metal block. The three openings in the cover shall be within the diameter of the sample well. When the slide is in the open position, the two openings in the slide shall coincide exactly with the two corresponding openings in the cover.

A1.1.2 Electrical heaters are attached to the cup in a manner that provides efficient transfer of heat. A heat control is required to hold the equilibrium temperature in a draft-free area within ±1°F (±0.5°C) for low-temperature testing, and ±4°F (±2.0°C) for high-temperature testing, throughout the duration of the test, measured on the mercury-in-glass thermometer. A visual indicator lamp shows when power is or is not being applied.

A1.2 *Test Flame and Pilot Flame-Regulatable Test Flame*, for dipping into the sample cup to try for flash, and a pilot flame, to maintain the test flame, are required. When inserted, the nozzle of the ignition device shall intersect the plane of the underside of the cover. These flames may be fueled from external propane supply<sup>5</sup> or from self-contained or attached tank of butane (**Warning**—See Note A1.1). A gage ring <sup>5</sup>/<sub>32</sub> in. (4 mm) in diameter, engraved on the lid near the test flame, is required to ensure uniformity in the size of the test flame.

NOTE A1.1: **Warning**—Never recharge or change the self-contained gas tank at elevated temperatures, or with the pilot or test flames lighted, nor in the vicinity of other flames.

A1.3 *Audible Signal* is required. The audible signal is given after 1 min in the case of the low-temperature testing and after 2 min in the case of high-temperature testing.

A1.4 *Syringe*, 2-mL capacity, equipped with a needle suitable for use with the apparatus, adjusted to deliver 2.00 ± 0.05 mL.

A1.5 *Syringe*, 5-mL capacity, equipped with a cap needle suitable for use with the apparatus, adjusted to deliver 4.0 ± 0.1 mL may be used with the high-temperature tester to provide a uniform-size portion.

TABLE A1.1 Essential Dimensions of Flash Test Apparatus<sup>A, B</sup>

	mm
<i>Sample Block:</i>	
Block diameter	61.5–62.5
Sample well diameter	49.40–49.70
Sample well depth	9.70–10.00
Top of block to center of thermometer hole	16.00–17.00
Diameter of thermometer hole	7.00 approx
<i>Cover:</i>	
Large opening length	12.42–12.47
Large opening width	10.13–10.18
Small opening length	5.05–5.10
Small opening width	7.60–7.65
Distance between extreme edges of small openings	48.37–48.42
Filling orifice diameter	4.00–4.50
Bore of filler tube	1.80–1.85
Maximum distance of filler tube from base of well with cover closed	0.75 max
<i>Slide:</i>	
Large opening length	12.42–12.47
Large opening width	10.13–10.18
Small opening length	5.05–5.10
Small opening width	7.60–7.65
Near edge of large opening to end of slide	12.80–12.85
Extremes of large and small openings	30.40–30.45
<i>Jet:</i>	
Length of jet	18.30–18.40
External diameter of end of jet	2.20–2.60
Bore of jet	1.60–1.65
Height of jet center above top surface of cover	11.00–11.20
Jet pivot to center of block with cover closed	12.68–12.72

<sup>A</sup> The O-ring seal or gasket, which provides a seal when the cover is shut, must be made of a heat-resistant material capable of withstanding temperatures up to 302°F (150°C) for the low-range apparatus and 608°F (320°C) for a high-range apparatus.

<sup>B</sup> When in position, the thermometer bulb must be surrounded with heat-conducting thermoplastic compound. (Heat Sink Compound is available from instrument sources.)

<sup>5</sup> External fuel adapters are available from instrument sources.

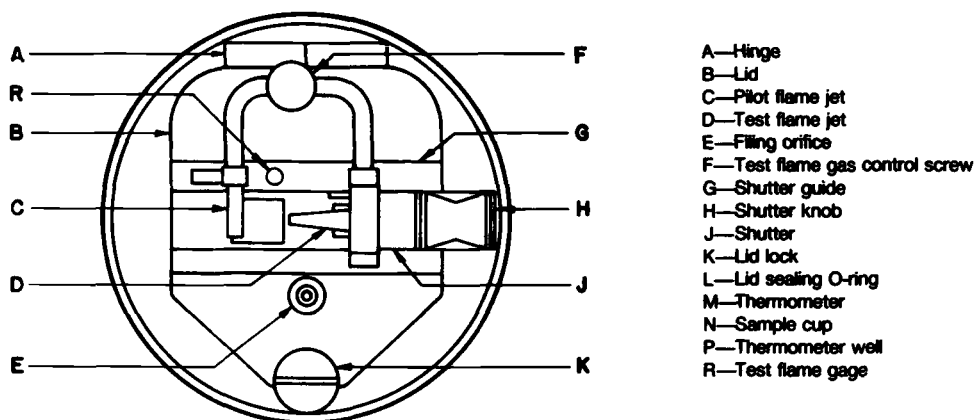

**BORE OF TEST JET**  
 1.65 / 1.60 DIA.

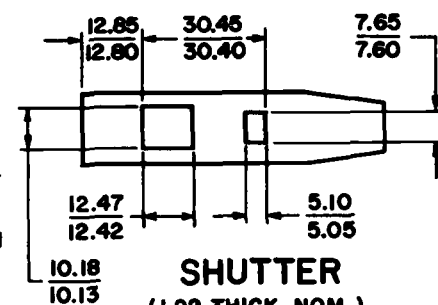
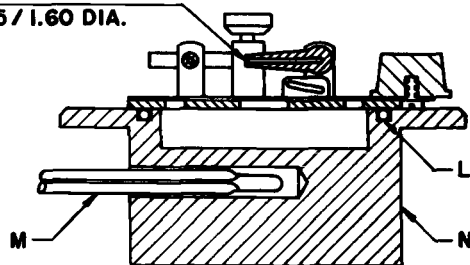

**BORE OF FILLING ORIFICE**  
 1.80 / 1.85 DIA.

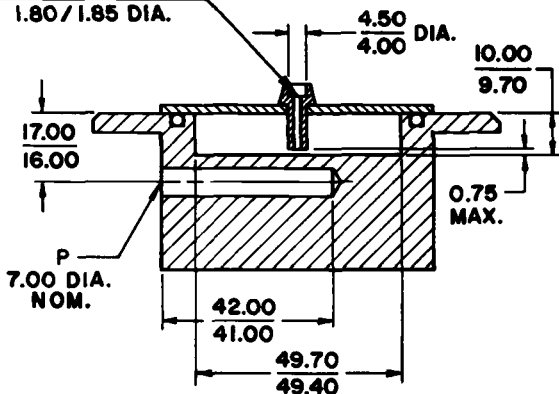

**SAMPLE CUP AND LID**

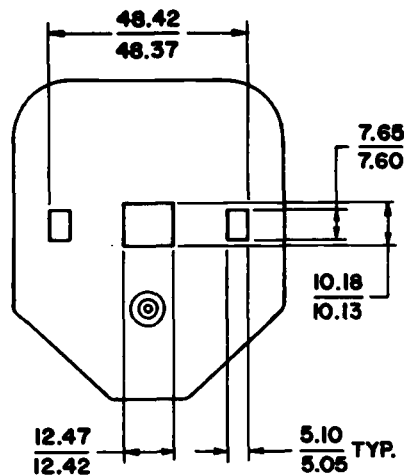

**LID (2.00 THICK NOM.)**

NOTE—All dimensions are in millimeters.

FIG. A1.1 Test Cup and Cover Assembly

The American Society for Testing and Materials takes no position respecting the validity of any patent rights asserted in connection with any item mentioned in this standard. Users of this standard are expressly advised that determination of the validity of any such patent rights, and the risk of infringement of such rights, are entirely their own responsibility.

This standard is subject to revision at any time by the responsible technical committee and must be reviewed every five years and if not revised, either reapproved or withdrawn. Your comments are invited either for revision of this standard or for additional standards and should be addressed to ASTM Headquarters. Your comments will receive careful consideration at a meeting of the responsible technical committee, which you may attend. If you feel that your comments have not received a fair hearing you should make your views known to the ASTM Committee on Standards, 1916 Race St., Philadelphia, PA 19103.



# Standard Test Method for Flash/No Flash Test—Equilibrium Method by a Closed-Cup Apparatus<sup>1</sup>

This standard is issued under the fixed designation D 3934; the number immediately following the designation indicates the year of original adoption or, in the case of revision, the year of last revision. A number in parentheses indicates the year of last reapproval. A superscript epsilon ( $\epsilon$ ) indicates an editorial change since the last revision or reapproval.

## INTRODUCTION

ASTM Flash Point Test Methods D 56, D 93, D 3278, and D 3941 are specified by government departments and agencies for determining whether liquids are flammable or combustible. These classifications are used as the basis for regulating the handling and shipping of liquids.

ISO/TC 35, Paints and Varnishes, and ISO/TC 28, Petroleum and Related Products, have issued ISO 1516 as a common standard, applicable to paints, varnishes, petroleum, and related products. This method is similar to ISO 1516 but uses standard ASTM cups and style and format. Test Methods D 3278 and D 3828 operate on the equilibrium principle by using the Setaflash tester which has a temperature-control device.

This test method does not determine the finite flash point but whether or not flashing occurs at a single specified temperature. The latter determination is made more accurate by ensuring that the test is carried out only when the material under test and the air/vapor mixture above it are in approximate equilibrium at the specified temperature.

## 1. Scope

1.1 This test method covers the determination of whether a liquid complies with the closed-cup flash point requirements in government regulations, or in specifications, or as agreed between the purchaser and the seller.

1.2 This test method is limited to a temperature range between 32 and 230°F (0 and 110°C).

1.3 *This standard should be used to measure and describe the properties of materials, products, or assemblies in response to heat and flame under controlled laboratory conditions and should not be used to describe or appraise the fire hazard or fire risk of materials, products, or assemblies under actual fire conditions. However, results of this test may be used as elements of a fire risk assessment which takes into account all of the factors which are pertinent to an assessment of the fire hazard of a particular end use.*

1.4 *This standard does not purport to address the safety problems associated with its use. It is the responsibility of the user of this standard to establish appropriate safety practices and to determine the applicability of regulatory limitations prior to use.*

## 2. Referenced Documents

### 2.1 ASTM Standards:

- D 56 Test Method for Flash Point by Tag Closed Tester<sup>2</sup>
- D 93 Test Methods for Flash Point by Pensky-Martens Closed Tester<sup>2</sup>

D 3278 Test Methods for Flash Point of Liquids by Setaflash Closed-Cup Apparatus<sup>2</sup>

D 3828 Test Method for Flash Point by Setaflash Closed Tester<sup>3</sup>

D 3941 Test Method for Flash Point by the Equilibrium Method with a Closed-Cup Apparatus<sup>2</sup>

E 1 Specification for ASTM Thermometers<sup>4</sup>

### 2.2 ISO Standard:

ISO 1516 Paints, varnishes, petroleum, and related products—Flash/no-flash test—Closed cup equilibrium method<sup>5</sup>

## 3. Terminology

### 3.1 Definition:

3.1.1 *flash point, n.*—the lowest temperature corrected to a pressure of 760 mm Hg (101.3 kPa) (1013 millibars) at which application of an ignition source causes the vapor of the specimen to ignite under specified conditions of test.

## 4. Summary of Test Method

4.1 A specimen in a closed cup of standard design is heated in a suitable liquid bath. After the specimen has been maintained under equilibrium conditions for at least 10 min at the lowest allowable flash point temperature (within a permitted tolerance) of the specification or regulation, it is determined whether the specimen does or does not flash.

## 5. Significance and Use

5.1 This test method ensures that before the flash test is

<sup>1</sup> This test method is under the jurisdiction of ASTM Committee D-1 on Paint and Related Coatings and Materials and is the direct responsibility of ASTM Subcommittee D01.22 on Health and Safety.

Current edition approved July 27, 1990. Published November 1990. Originally published as D 3934 – 82. Last previous edition D 3934 – 84<sup>1</sup>.

<sup>2</sup> *Annual Book of ASTM Standards*, Vol 06.03.

<sup>3</sup> *Annual Book of ASTM Standards*, Vol 05.03.

<sup>4</sup> *Annual Book of ASTM Standards*, Vols 05.03 and 14.03.

<sup>5</sup> Available from American National Standards Institute, 1430 Broadway, New York, NY 10018.

run the air/vapor space above the specimen has attained a saturation concentration of vapor by using standard closed cups under equilibrium conditions. The saturation concentration of the vapors will be attained at some temperature between that of the liquid and the cooler apparatus lid. However, this temperature will be close to the temperature of the specimen after it has been maintained at the specified temperature for at least a 10-min period. This test method does not provide for the determination of the actual flash point but only whether a specimen does or does not flash at a specified temperature.

## 6. Apparatus

6.1 *Test Cups*, specified in Test Methods D 56 (Tag) and D 93 (Pensky-Martens). Remove the test cup assembly (including lid and specimen thermometer) from the Tag and Pensky-Martens apparatus to permit either to be used in a separate water bath.

NOTE 1—If a stirrer is fitted to the test cup, it shall be operated during the heating period but must be stopped during the flashing determination. If a stirrer originally fitted to the test cup is removed, the aperture in the cover shall be securely plugged before starting the test.

6.2 *Water Bath*, capable of being adjusted to the required specification temperature and of adequate heat capacity to meet the requirements of the test. A bath fitted with a stirrer and an adjustable thermostat is convenient.

NOTE 2—The bath should be fitted with a cover, especially when the specified temperature is above 160°F. At about this temperature the inerting effect of the water vapor may prevent or delay the flashing of the liquid under test.

6.3 *Thermometers*—Standard thermometers specified in Test Methods D 56 and D 93. One thermometer shall be used to measure the temperature of the water bath and one shall be used for measuring the temperature of the specimen in the cup.

NOTE 3—The thermometers for the water bath should be mounted in the bath at the correct level of immersion for which they are specified in Specification E1.

6.4 *Support*, for holding the test cup in the water bath so that the cover and upper edge are horizontal and the cup is immersed in direct contact with the water in such a position that the level of the specimen in the cup is the same as that of the liquid in the water bath.

6.5 *Shield*—A three-sided shield open in the front, each side 18 in. (460 mm) wide and 24 in. (610 mm) high, is recommended.

## 7. Reagents and Materials

7.1 *Water or a 1 + 1 Mixture of Water and Ethylene Glycol* may be used as the bath liquid.

## 8. Preparation of Sample

8.1 Obtain a representative sample of the product under test and keep it in an air-tight container.

8.2 Because of the possibility of loss of volatiles, the sample shall receive only the minimum treatment to assure uniformity. After removal of the specimen, immediately close the sample container tightly to assure that no volatile flammable components escape from the container (otherwise a new sample may be necessary if further testing is required).

8.3 Do not open containers unnecessarily. Do not make transfers unless the sample temperature is at least 20°F (10°C) below the flash point.

8.4 Discard samples in leaky containers.

8.5 Do not store samples in plastic (polyethylene, polypropylene, etc), since volatile material may diffuse through the walls of the bottles.

## 9. Preparation of Apparatus

9.1 Support the cup and water bath on a level, steady table. Unless tests are made in a draft-free room or compartment, surround the tester on three sides with the shield for protection from drafts. Tests made in a laboratory draft hood or near ventilation are not reliable.

9.2 Adjust the temperature of the bath to, and maintain it within 1.0°F (0.5°C) of the specified test temperature, correcting this temperature for any difference from standard barometric pressure by raising the test temperature for a higher pressure or lowering it for a lower pressure.

9.3 Carefully clean and dry the test cup, the cover, and the cup thermometer and bring them to at least 4°F (2°C) below the minimum specified test temperature.

## 10. Procedure

10.1 Fill the test cup with the appropriate amount of specimen for the cup being used at a temperature that is at least 20°F (10°C) below the specified test temperature, corrected for barometric pressure (Note 4). Remove bubbles on the surface of the specimen. Wipe the inside of the cover with a clean cloth or absorbent tissue paper.

NOTE 4—Correct the temperature at which the test is to be performed in accordance with the appropriate equation:

$$^{\circ}\text{F} = S - 0.06 (760 - P)$$

$$^{\circ}\text{C} = T - 0.03 (760 - P)$$

$$^{\circ}\text{F} = S - 0.42 (101.3 - B)$$

$$^{\circ}\text{C} = T - 0.23 (101.3 - B)$$

where:

$^{\circ}\text{F}$ ,  $^{\circ}\text{C}$  = test temperature when the barometric pressure differs from 760 mm of Hg (101.3 kPa),

$S$  ( $T$ ) = specified flash point,  $^{\circ}\text{F}$  ( $^{\circ}\text{C}$ ), and

$P$  ( $B$ ) = actual barometric pressure, mm of Hg (kPa).

10.2 Immediately after filling the cup, place the cover in position and support the cup in the bath so that the cover is horizontal and the cup is immersed in direct contact with the water and with the surface of the specimen at the same level as the liquid in the bath.

10.3 Light the flame of the ignition device and adjust it to the size of a bead of diameter  $\frac{5}{32}$  in. (4 mm).

10.4 Adjust the temperature of the specimen to within 1.0°F (0.5°C) of the minimum corrected test temperature and hold at this temperature for 10 min. Apply the test flame by opening the slide, inserting and removing the nozzle of the ignition device, and closing the slide again, over a period of  $2.5 \pm 0.5$  s. While the test flame is inserted observe whether there is a flash.

NOTE 5—When the vapor mixture under test is near the flash-point temperature, application of the test flame may give rise to a halo; however, the material is only deemed to have flashed if a comparatively large blue flame appears and propagates itself over the surface of the liquid. If a large blue flame does not appear as a flash but instead a continuous luminous flame burns in the orifice when the slide is opened



and the ignition flame introduced, then the flash point is much lower than the test temperature. In such circumstances, if further classification is desired, test a fresh specimen at the temperature limit for the next lower flash point classification.

10.5 Repeat the test using a fresh specimen.

## 11. Report

11.1 Report the following:

11.1.1 Whether the product did, or did not, flash at the specified flash point, and

11.1.2 The cup used.

## 12. Precision and Bias

12.1 *Precision:*

12.1.1 While the precision of Test Method D 3934 has not been determined, the precision of a similar definitive test described in Test Method D 3941 can be used as an indication of the precision of Test Method D 3934. This test method also can be compared to results in the flash, no-flash

procedures in Test Methods D 3278 and D 3828 which are equilibrium methods.

12.1.2 The precision of flash point determinations is improved by the use of equilibrium methods. While vapors in this method will reach an equilibrium at some temperature between that of the liquid and that of the cooler apparatus cover, the temperature of the liquid under conditions of Test Method D 3934 will more closely approach true equilibrium between the liquid under test and the vapor-air mixture above it than in other methods run at finite heating rates.

12.2 *Bias:*

12.2.1 The procedure in this test method has no bias because the value of whether the material did or did not flash can be defined only in terms of a test method.

## 13. Keywords

13.1 closed cup; flash/no flash; flash point; Pensky-Martens; Tag

*The American Society for Testing and Materials takes no position respecting the validity of any patent rights asserted in connection with any item mentioned in this standard. Users of this standard are expressly advised that determination of the validity of any such patent rights, and the risk of infringement of such rights, are entirely their own responsibility.*

*This standard is subject to revision at any time by the responsible technical committee and must be reviewed every five years and if not revised, either reapproved or withdrawn. Your comments are invited either for revision of this standard or for additional standards and should be addressed to ASTM Headquarters. Your comments will receive careful consideration at a meeting of the responsible technical committee, which you may attend. If you feel that your comments have not received a fair hearing you should make your views known to the ASTM Committee on Standards, 1916 Race St., Philadelphia, PA 19103.*



# Standard Test Method for Flash Point by the Equilibrium Method With a Closed-Cup Apparatus<sup>1</sup>

This standard is issued under the fixed designation D 3941; the number immediately following the designation indicates the year of original adoption or, in the case of revision, the year of last revision. A number in parentheses indicates the year of last reapproval. A superscript epsilon ( $\epsilon$ ) indicates an editorial change since the last revision or reapproval.

## INTRODUCTION

Test Methods D 56 and D 93 describe procedures using the Tag Closed Tester and the Pensky-Martens Tester, respectively. Both test methods depend on a definite rate of temperature increase to control the precision of the test method. The rate of heating may not in all cases give the accuracy expected because of low thermal conductivity of certain materials. To reduce this effect, ISO/TC 35, Paints and Varnishes, and ISO/TC 28, Petroleum Products and Lubricants, have issued ISO 1523 in which the heating rate is considerably slower. This test method is similar to ISO 1523, but uses standard ASTM cups, style, and format. Due to the slower heating rate, the time required to make a determination of a flash point is considerably longer than for Test Methods D 56 and D 93 but the accuracy is improved.

### 1. Scope

1.1 This test method covers the determination of the flash point of liquids in which the specimen and the air/vapor mixture above it are approximately in temperature equilibrium.

1.2 This test method is limited to a temperature range from 32 to 230°F (0 to 110°C).

1.3 *This standard should be used to measure and describe the properties of material, products, or assemblies in response to heat and flame under controlled laboratory conditions and should not be used to describe or appraise the fire hazard or fire risk of materials, products or assemblies under actual fire conditions. However, results of this test may be used as elements of a fire risk assessment which takes into account all of the factors which are pertinent to an assessment of the fire hazard of a particular end use.*

1.4 *This standard does not purport to address the safety problems associated with its use. It is the responsibility of the user of this standard to establish appropriate safety and health practices and determine the applicability of regulatory limitations prior to use.*

### 2. Referenced Documents

#### 2.1 ASTM Standards:

D 56 Test Method for Flash Point by Tag Closed Tester<sup>2</sup>

D 93 Test Methods for Flash Point by Pensky-Martens Closed Tester<sup>2</sup>

E 1 Specification for ASTM Thermometers<sup>3</sup>

<sup>1</sup> This test method is under the jurisdiction of ASTM Committee D-1 on Paint and Related Coatings and Materials and is the direct responsibility of Subcommittee D01.22 on Health and Safety.

Current edition approved May 25, 1990. Published July 1990. Originally published as D 3941 – 80. Last previous edition D 3941 – 84<sup>1</sup>.

<sup>2</sup> Annual Book of ASTM Standards, Vol 06.03.

<sup>3</sup> Annual Book of ASTM Standards, Vols 05.03 and 14.03.

#### 2.2 ISO Standard:

ISO 1523 Paints, varnishes, petroleum, and related products—Determination of flash point—Closed cup equilibrium method<sup>4</sup>

### 3. Terminology

#### 3.1 Definition:

3.1.1 *flash point, n*—the lowest temperature corrected to a pressure of 760 mm Hg (101.3 kPa) (1013 millibars) at which application of an ignition source causes the vapor of the specimen to ignite under specified conditions of test.

### 4. Summary of Test Method

4.1 A specimen is heated in a closed cup of standard design in a suitable water bath at the rate of 1.0°F (0.5°C) in not less than 1.5 min so that the difference in temperature between the specimen in the cup and bath never exceeds 3.5°F (2.0°C). Flash determinations are made at intervals of not less than 1.5 min.

### 5. Significance and Use

5.1 This test method, using a slow rate of heating, provides a uniform temperature throughout the specimen. The slow rate of heating is necessary because of the low thermal conductivity of some liquids such as paints, resins, and related products, and also because of the poor heat transfer by convection in high-viscosity products. Since the specimen is being heated at a reduced rate, the longer time interval between each determination is necessary to reestablish after each flash test the saturation concentration of vapor in the air space above the specimen.

NOTE 1—ISO 1523 is used in United Nations Recommendations for Transportation of Dangerous Goods and in the International Civil Aviation Organization (ICAO) regulations and for similar regulations in the International Maritime Dangerous Goods (IMDG) code. Test Method D 3941, which is similar to ISO 1523, is used in the United States

<sup>4</sup> Available from American National Standards Institute, 1430 Broadway, New York, NY 10018.

Department of Transportation (USDOT) regulations. The ICAO and IMDG codes are used for transshipment of hazardous materials through the United States to other countries.

## 6. Apparatus

6.1 *Test Cups*, equipped with their lid as specified in Test Methods D 56 (Tag) and D 93 (Pensky-Martens). Remove the test cup assembly (including lid and specimen thermometer) from the Tag and Pensky-Martens apparatus to permit either to be used in a separate water bath.

6.1.1 If a stirrer is fitted to the test cup used, it shall operate during the heating period but must be stopped during the flashing determination. If the stirrer originally fitted to the test cup is removed, the aperture in the cover shall be securely plugged before starting the test.

6.2 *Water Bath*—Any suitable water bath capable of being adjusted to the required temperature and of adequate heat capacity to meet the requirements of the test. A bath fitted with a stirrer and an adjustable thermostat is convenient.

NOTE 2—The bath should be fitted with a cover, especially when the specified temperature is above 160°F. At about this temperature the inerting effect of the water vapor may prevent or delay the flashing of the liquid under test.

6.3 *Thermometers*—Standard thermometers as specified in Test Methods D 56 and D 93. One thermometer shall be used to measure the temperature of the water bath and one shall be used for measuring the temperature of the specimen in the cup.

NOTE 3—The thermometers for the water bath should be mounted at the correct level of immersion for which they are specified in Specification E 1.

6.4 *Support*, for holding the test cup in the water bath so that the cover and upper edge are horizontal and the cup is immersed in direct contact with the water in such a position that the level of the specimen in the cup is the same as that of the liquid in the water bath.

6.5 *Shield*—A three sided shield, open in front, each side 18 in. (460 mm) wide and 24 in. (610 mm) high, is recommended.

## 7. Reagents and Materials

7.1 *Water or Mixture of Water and Ethylene Glycol (1+1)* may be used as a bath liquid.

## 8. Preparation of Sample

8.1 Obtain a representative sample of the product under test and keep in an air-tight container.

8.2 Because of the possibility of loss of volatile constituents, the sample should receive only the minimum treatment to assure uniformity. After removing the specimen, immediately close the sample container tightly to assure that no volatile flammable components escape from the container (otherwise a new sample may be necessary if further testing is required).

8.3 Do not open containers unnecessarily. Do not make transfers unless the sample temperature is at least 20°F (10°C) below the expected flash point, except for materials that are too viscous to be handled at that temperature. In these cases, transfer the specimens at the lowest possible

temperature at which the material can be accurately measured into the cup.

8.4 Discard samples in leaky containers.

8.5 Do not store samples in plastic (polyethylene, polypropylene, etc.) bottles, since volatile material may diffuse through the walls of the bottles.

## 9. Preparation of Apparatus

9.1 Support the cup and water bath on a level steady table. Unless tests are made in a draft-free room or compartment, surround the tester on three sides by the shield for protection from drafts. Tests made in a laboratory draft hood or near ventilators are not reliable.

9.2 Adjust the temperature of the bath to 10°F (5°C) below the approximate flash point determined by Section 10.

9.3 Carefully clean and dry the test cup, the cover, and the cup thermometer, and bring them to approximately the same temperature as the bath liquid.

## 10. Procedure

10.1 *Preliminary Test*—Determine the approximate flash point of the material by one or more preliminary tests. See 10.2 through 10.7.

10.2 Fill the test cup with the appropriate amount of specimen for the cup being used at a temperature that is at least 20°F (10°C) below the approximate flash point (10.1). (See 8.3 for viscous materials.) Remove any bubbles on the surface of the specimen. Wipe the inside of the cover with a clean cloth or absorbent tissue paper.

10.3 Immediately after filling the test cup, place the cover in position and support the cup in the bath so that the cover is horizontal and the cup is immersed in direct contact with the bath liquid and with the surface of the specimen at the same level as or below that of the liquid in the bath. Confirm that the bath is at a temperature 10°F (5°C) below the approximate flash point.

10.4 Light the flame of the ignition device and adjust it to the size of a bead of diameter  $\frac{5}{32}$  in. (4.0 mm).

10.5 As soon as the specimen has attained the same temperature as the bath (that is, the starting temperature of the definitive tests), perform a flash point test by opening the slide, inserting and removing the test flame, and closing the slide again, over a period of  $2.5 \pm 0.5$  s. While the test flame is inserted, observe whether there is a flash.

10.6 If ignition occurs (Note 4), the initial temperature selected was too high. Repeat the complete procedure from 10.2 with a fresh specimen at a temperature about 10°F (5°C) lower.

NOTE 4—When the vapor mixture under test is near the flash-point temperature, application of the test flame may give rise to a halo; however, the product is only deemed to have flashed if a comparatively large flame appears and propagates itself over the surface of the liquid. If a large blue flame does not appear as a flash, but instead a continuous luminous flame burns in the orifice when the slide is opened and the ignition flame introduced, then the flash point of the product is much lower than the test temperature.

10.7 If no ignition occurs (Note 4), heat the bath at a rate such that the difference in temperature between the bath and the specimen never exceeds 3.5°F (2°C). When the specimen has increased in temperature by 1°F (0.5°C) (that is, after not less than 1.5 min nor more than 5 min), repeat the ignition

test, and if no ignition occurs, repeat the procedure until a temperature is reached at which ignition occurs. Read to the nearest 1°F (0.5°C) the temperature indicated by the cup thermometer.

10.8 Make two determinations repeating the procedure from 10.2, using the flash point temperature determined in 10.7 as the initial temperature. Correct each temperature reading for any known thermometer correction and record the result as the flash point temperature at the barometric pressure prevailing during the test. Record also the barometric pressure in millimetres of mercury or kilopascals. Correct each flash point reading when the barometric pressure differs from 760 mm Hg (101.3 kPa). (see 11.1). Determine the mean of the corrected results of the two determinations.

NOTE 5—As volatile components are liable to be present in the products being tested, the total duration of the test should not exceed 1 h.

### 11. Calculation of Correction for Barometric Pressure

11.1 When the barometric pressure differs from 760 mm Hg (101.3 kPa) calculate the corrected flash point temperature  $T$  by means of the following equation:

$$T = F + 0.06 (760 - P) \\ = C + 0.03 (760 - P)$$

*The American Society for Testing and Materials takes no position respecting the validity of any patent rights asserted in connection with any item mentioned in this standard. Users of this standard are expressly advised that determination of the validity of any such patent rights, and the risk of infringement of such rights, are entirely their own responsibility.*

*This standard is subject to revision at any time by the responsible technical committee and must be reviewed every five years and if not revised, either reapproved or withdrawn. Your comments are invited either for revision of this standard or for additional standards and should be addressed to ASTM Headquarters. Your comments will receive careful consideration at a meeting of the responsible technical committee, which you may attend. If you feel that your comments have not received a fair hearing you should make your views known to the ASTM Committee on Standards, 1916 Race St., Philadelphia, PA 19103.*

$$= F + 0.42 (101.3 - B) \\ = C + 0.23 (101.3 - B)$$

where:

$F (C)$  = observed flash point, °F (°C) and

$P (B)$  = barometric pressure, mm of Hg (kPa).

### 12. Report

12.1 Report the flash point (the mean of two results) to the nearest 1°F (0.5°C) and the cup used in the test.

### 13. Precision and Bias

13.1 *Precision*—ISO reported the following:

13.1.1 *Repeatability*—Two results, each the mean of two determinations, obtained by the same operator using the same apparatus should be considered suspect if they differ by more than 3.5°F (2°C).

13.1.2 *Reproducibility*—Two results, each the mean of two determinations, obtained by operators in different laboratories should be considered suspect if they differ by more than 5°F (3°C).

13.2 *Bias*—The procedure for measuring flash point in this test method has no bias because the value of the flash point can be defined only in terms of a test method.

### 14. Keywords

14.1 closed cup; equilibrium method; flash point; Pensky-Martens; Tag

# 3

## ASTM Flash Point Standards for Specific Products (Excerpts)

### INTRODUCTION

There are a number of standard methods and practices that use the basic flash point methods with or without modification. The modifications are made to suit the needs of the particular product or type of products. The section or sections of the standard excerpts below that specify the basic flash point test(s) are shown with their number, title, and date designation.

If a specific section has a Scope, a Summary of Method, or a Significance and Use statement, these are shown under the section title.

NOTE—All flash point standards referenced herein are included in this manual as part of Chapter 2.

### 1. ASTM D 115-85 METHODS OF TESTING VARNISHES USED FOR ELECTRICAL INSULATION

#### Flash Point

#### 19. Significance and Use

19.1 Flash point approximates the lower temperature limit of flammability, or the temperature at which the con-

TABLE 3-1—Quick Reference to ASTM Standard Methods that cite flash point standards.

ASTM Standards/BOS Volume	Flash Point Standard Cited	Sections Citing Flash Point
D 115-85/10.01	D 56, D 93, D 3278	20.1
D 117-89/10.03	D 92	8.3
D 154-85(1989)/06.01	D 56, D 93, D 1310, D 3278	9.1
D 176-85(1989)/10.01	D 92	10.1
D 268-85/06.03	D 56, D 93, D 1310, D 3278	18.2
D 333-87/06.01	D 56, D 93, D 3278	11.2, 11.3
D 555-84(1988)/06.03	D 56, D 93, D 1310	24.4
D 801-57(1987)/06.03	D 56	14.1
D 803-82(1987)/06.03	D 93	12.1
D 901-86/10.03	D 92	36.1
D 1131-53(1981)/06.03	D 92, D 93	7.1
D 1168-84(1989)/05.01, 10.01	D 92	5.1
D 2071-87/06.03	D 56, D 93, D 1310, D 3278	15.2, 15.3, 15.4
D 2225-86/10.03	D 92	7.2
D 2554-81(1989)/15.04	D 56, D 92	7.1, 7.2
D 2689-88/06.02	D 93, D 3278	13.1
D 2833-89/06.01	D 56, D 93, D 1310, D 3278	Table 2.1
D 2939-78/04.04	D 92	12.1
D 3065-72(1981)/15.09	D 1310	8, 9, 10, 11, 12
D 3105-85/04.04	D 92, D 93, D 1310, D 3278	5.2
D 3143-83(1989)/04.03	D 92, D 1310	1.1
D 3288-82/10.02	D 56	15.1
D 3323-80(1988)/06.01	D 93, D 1310, D 3278	6.7
D 3425-80(1988)/06.01	D 93, D 3278	6.11
D 3436-86/06.03	D 56, D 92, D 1310, D 3934	3.1
D 3437-89/06.03	Fire Hazard	5.2
D 3666-90/04.03	D 92	8.2
D 3745-78(1989)/04.04	D 92	3.3
D 3757-89/15.04	D 56, D 93, D 3278, D 3828	8.2
D 3809-79(1988)/10.03	D 92	7.2
D 4277-83(1988)/06.02	D 3278	12.1
D 4712-87/06.01	D 56, D 93, D 3278	9.13
D 4733-87/10.01	D 93, D 3278	8.4
E 502-84/14.02	D 56, D 93, D 1310, D 3278, D 3941	12.1
E 752-89/11.03	D 56	5.7, 1.2

centration of the vapors of a liquid in air equals the lower flammability limits. It is used in regulations for storage, transportation, handling, and use of a liquid by U.S. regulatory agencies, and state and local ordinances or codes.

## 20. Procedure

20.1 Determine flash point in accordance with one of the following methods, depending on viscosity, type of material, and anticipated flash point:

- 20.1.1 Test Method D 56,
- 20.1.2 Test Method D 93, or
- 20.1.3 Test Method D 3278.

## 21. Report

21.1 The report shall include the following:

- 21.1.1 Identification of the varnish used, and
- 21.1.2 Flash point and method used. The flash point shall be reported as the average value in degrees Celsius or degrees Fahrenheit, corrected to standard barometric pressure.

## 2. ASTM D 117-89 GUIDE TO TEST METHODS AND SPECIFICATIONS FOR ELECTRICAL INSULATING OILS OF PETROLEUM ORIGIN

### 8. Flash and Fire Point

#### 8.1 Scope

8.1.1 This test method covers the determination of flash and fire points of all petroleum products except fuel oils and those having an open-cup flash below 79°C (175°F).

8.1.2 This test method should be used solely to measure and describe the properties of materials in response to heat and flame under controlled laboratory conditions and should not be used for the description, appraisal, or regulation of the fire hazard of materials under actual fire conditions.

8.3 *Summary of Test Method*—Fill the test cup to the specified level with the sample. Heat the sample initially at 14° to 17°C/min (25° to 30°F/min) until the temperature is 56°C (100°F) below the expected flash point. Reduce the rate of temperature change to 5° to 6°C/min (9° to 11°F/min) and apply the test flame every 2°C (or 5°F) until a flash occurs. Continue heating and testing every 2°C (or 5°F) until the oil continues to burn for at least 5 s. The procedure is described in Method D 92, Test for Flash and Fire Points by Cleveland Open-Cup.

8.4 *Significance and Use*—The flash point and fire point tests give an indication of the flammability of an oil. They may also be used to provide a qualitative indication of contamination with more flammable materials. In the latter context, the flash point test is more sensitive.

## 3. ASTM D 154-85 (REAPPROVED 1989)<sup>e1</sup> METHODS OF TESTING VARNISHES

### 9. Flash Point

9.1 Determine the flash point of varnishes having a viscosity of less than 9.5 cSt at 25°C (77°F) (45 SUS at 100°F)

by Test Method D 56, and of varnishes having a viscosity of more than 9.5 cSt at 77°F by Test Methods D 93. Alternatively, use Test Methods D 3278, which gives comparable results to Test Methods D 56 and D 93.

NOTE—Due to various U.S. Government and State regulations, it is now necessary to check with appropriate departments to determine which ASTM Test Method is applicable.

## 4. ASTM D 176-85 (REAPPROVED 1989)<sup>e1</sup> METHODS OF TESTING SOLID FILLING AND TREATING COMPOUNDS USED FOR ELECTRICAL INSULATION

### Flash and Fire Points

#### 9. Significance and Use

9.1 The flash and fire points must be high enough so that the possibility of an explosion or fire is at a minimum when the compounds are being heated and poured. A flash point at least 35°C (63°F) above the pouring temperature is usually considered necessary for safe operations. An unusually low flash point for a given compound indicates admixture or contamination with more volatile material. The test is useful for purposes of specification, classification, and control of product uniformity.

#### 10. Procedure

10.1 Determine the flash and fire points of all compounds in accordance with Test Method D 92.

10.2 In the case of certain compounds containing chlorine, the flash may be indefinite and no fire point may exist. This fact should be reported.

## 5. ASTM D 268-85 METHODS OF SAMPLING AND TESTING VOLATILE SOLVENTS AND CHEMICAL INTERMEDIATES FOR USE IN PAINT AND RELATED COATINGS AND MATERIALS

### 18. Flash Point

18.2 There are four methods currently used to determine the flash points of volatile solvents. One uses an open cup that allows the solvent vapors to disperse into ambient air during the determination while three use a closed-cup that confines the solvent vapors. Flash point values obtained with the open-cup are higher than those measured in closed cups. Current U.S. DOT regulations require the measurement of flash points by the applicable closed-cup procedure to define the characteristics of a product for labelling and transport purposes. Flash points may be determined by the following methods:

18.2.1 *Test Method D 1310, Tag Open Cup*—A temperature range from -18 to 168°C (0 to 325°F) is covered by this instrument.

18.2.2 *Test Method D 56, Tag Closed Cup*—This apparatus is applicable to solvents with a viscosity at 38°C (100°F)

below 45 SUS (9.5 cSt or mm<sup>2</sup>/s at 25°C) (77°F) and which flash below 93°C (200°F).

18.2.3 *Test Methods D 93, Pensky-Martens Closed-Cup*—With a range from -7 to 370°C (20 to 700°F), this unit is applicable to products with flash points higher than those obtainable with either the Tag Closed Tester or the Setaflash Tester. In addition, with its stirrer it is applicable to liquids having a viscosity greater than 9.5 cSt (mm<sup>2</sup>/s) at 25°C, having a tendency to skin over, or containing suspended solids.

18.2.4 *Test Methods D 3278, Setaflash Closed Tester*—The construction of this instrument permits the use of a small, 2-mL specimen and is applicable in the range from 0° to 110°C (32 to 230°F) to liquids with viscosities below 150 St (1.50 mm<sup>2</sup>/s) at 25°C (77°F). One may determine the finite flash point of a liquid or whether the liquid will or will not flash at a certain temperature.

## 6. ASTM D 333-87 METHOD OF TESTING CLEAR AND PIGMENTED LACQUERS

### 11. Flash Point

11.1 The organic solvents used in lacquers have characteristic flash points. The flash point of a liquid is defined as the lowest temperature, corrected to 101.3 kPa (760 mm Hg) of pressure, of the sample at which application of an ignition source causes the vapor of the sample to ignite under specified conditions of test.

11.2 Determine the flash point by Test Method D 56 or Test Methods D 93 for liquid storage regulations of OSHA of U.S. Department of Labor and for classification of hazardous liquids for shipments under the regulations of U.S. DOT and bulk shipments by water.

11.2.1 Determine the flash point of lacquer or lacquer materials having a viscosity less than 9.5 cSt at 25°C (77°F) or 45 SUS at 37.8°C (100°F) (Method D 88) by Test Method D 56 and of lacquers having a viscosity of more than 9.5 cSt at 25°C (77°F) or 45 SUS at 37.8°C (100°F) by Method A of Test Methods D 93. Use Method B of Test Methods D 93 whenever there is a question that the heat transfer within a viscous lacquer is not sufficient to assure an accurate flash point. In addition, use Method B when testing pigmented lacquers or suspensions of solids and liquids which tend to skin under test conditions.

11.3 Test Methods D 3278, which give comparable results to Test Method D 56 and Test Methods D 93 while requiring a smaller specimen and less time to run, may be used as an alternative method.

## 7. ASTM D 555-84 (REAPPROVED 1988) GUIDE FOR TESTING DRYING OILS

### 24. Flash Point

24.2 Most natural and synthetic drying oils have very high flash points of about 260°C (500°F), unless they contain traces of volatile, flammable materials. If the contaminating solvent is known, it is possible to set up a relationship between the solvent content and the flash point.

24.3 Flash point of vegetable oils is helpful in determining that no hazardous amounts of solvents have been left in solvent-extracted oils, or that the oils have been contaminated with such solvents. If flammable solvents are not present, the flash point of natural oils is meaningless as far as specifications are concerned.

24.4 Determine the flash point in accordance with Test Method D 93 which uses the Pensky-Martens Closed Cup. Use Method B for Testing flash point of highly viscous materials. The exact flash point obtained is empirical, depending upon the rate of heating and other factors set forth in the test method. These must be followed carefully if reasonable precision is to be obtained.

NOTE 2—If open-cup methods, such as Test Method D 1310 are used, traces of flammable solvents may evaporate and be lost without ever igniting and an unduly high result may be obtained. Since many oils are fairly viscous liquids, the use of methods that do not provide for stirring, such as Test Method D 56, may give anomalous results.

## 8. ASTM D 801-57 (REAPPROVED 1987) METHODS OF SAMPLING AND TESTING DIPENTENE

### 14. Flash Point

14.1 Determine the flash point by means of the Tag Closed Tester as described in Test Method D 56.

## 9. ASTM D 803-82 (REAPPROVED 1987) METHODS OF TESTING TALL OIL

### Flash Point

### 12. Procedure

12.1 Determine the flash point in accordance with Method D 93.

## 10. ASTM D 901-86 METHODS OF TESTING ASKARELS

### Fire Point

### 35. Significance and Use

35.1 Askarels, as such, have no fire point. The test is only of value, therefore, in showing whether the material has the nonflammable characteristics required of an askarel, or has a large amount of combustible contaminant.

### 36. Procedure

36.1 Verify the lack of a fire point in accordance with Test Method D 92. The verification temperature shall be 200°C (392°F).

**11. ASTM D 1131-53 (REAPPROVED 1981)  
METHODS OF TESTING ROSIN OILS****7. Flash Point**

7.1 Determine the flash point of the oil either in accordance with Test Method D 92 or in accordance with Test Method D 93. Report the method used.

**12. ASTM D 1168-84 (REAPPROVED 1989)  
METHODS OF TESTING HYDROCARBON WAXES USED FOR ELECTRICAL INSULATION**

5.1.5 *Flash and Fire Points*—Test Method D 92.

**13. ASTM D 1569-62 (REAPPROVED 1987)<sup>e1</sup>  
METHODS OF TESTING DETERGENT ALKYLATE****Flash Point****5. Procedure**

5.1 Determine the flash point in accordance with Test Method D 92.

**14. ASTM D 2071-87 METHODS FOR  
FATTY NITROGEN PRODUCTS****15. Flash Points**

15.1 Flash points are run on quaternaries to determine whether they must be classified as flammable under government regulations.

15.2 Determine flash point of quaternaries having a viscosity less than 45 SUS at 100°F (9.5 cSt at 77°F) (Test Method D 88) by Test Method D 56 and flash point of quaternaries having a viscosity of 45 SUS at 100°F or more by Test Methods D 93. In addition, test suspensions of solids or liquids that tend to skin by Test Methods D 93.

**15.3 Regulatory:**

15.3.1 Determine the flash point by Test Method D 56 or by Test Methods D 93 for liquid storage regulations of OSHA of U.S. Dept. of Labor and for classification of hazardous liquids for shipments by all common carriers under the regulations of U.S. DOT.

15.3.2 Determine flash point of liquids regulated by the U.S. Consumer Product Safety Commission by Test Method D 1310.

15.4 Test Methods D 3278, which give comparable results to Test Method D 56 and Test Methods D 93 but requires less sample and less time to run than the latter methods, may be used to check flash point of quaternaries. The U.S. DOT specifies its use as an alternative method to the methods specified in 14.3.1.

**15. ASTM D 2225-86 METHODS OF  
TESTING SILICONE FLUIDS USED  
FOR ELECTRICAL INSULATION****7. Flash and Fire Points**

7.1 *Significance*—The flash and fire points of a silicone insulating fluid indicates the limit to which the material may be heated, under the specified test conditions, before the emitted vapors form a flammable mixture in air. Unusually low flash or fire points for a given product may indicate contamination.

7.2 *Procedure*—Determine the flash and fire points in accordance with Test Method D 92.

**16. ASTM D 2554-81 (REAPPROVED 1989)  
TEST FOR FLASH POINT OF  
DRYCLEANING DETERGENTS IN  
THE DRYCLEANING BATH****Flash Point****1. Scope**

1.1 This test method covers the determination of the flash point of drycleaning detergents of both the charge and non-charge type. It can be used to ascertain compliance with the flash point requirements of Specification D 2763, and Specification D 2762.

1.2 It is the aim of the specification requirement to exclude those detergents which decrease the flash point of a drycleaning solvent by being mixed with it.

**4. Summary of Test Method**

4.1 The detergent dissolved at a stated use concentration in a specific drycleaning solvent is tested for flash point up to the flash point of the drycleaning solvent by methods appropriate to the boiling point of the solvent-detergent mixture.

**5. Significance and Use**

5.1 The results of this test will be significant only in cases where a stable, homogeneous mixture of the detergent in the drycleaning solvent can be achieved for the period of the test.

5.2 The test is carried out at the maximum or normal use concentrations of the detergent in the drycleaning solvent. Results may be of no significance should higher detergent concentrations be used.

**7. Procedure**

7.1 For a detergent dissolved in Stoddard (petroleum) solvent or a solvent believed to have a flash point below 79°C, test in accordance with Method D 56.

7.2 When the drycleaning fluid has a flash point exceeding 79°C, test in accordance with Method D 92.

7.3 Concentration of solvent-detergent mixtures shall be as follows:

7.3.1 *Liquid Charge Type*—Use at 4% concentration by volume.



## 60 FLASH POINT STANDARDS AND THEIR USE

7.3.2 *Non-charge Type*—Dissolve at normal use concentrations.

NOTE—Test shall be run at 4 volume % of detergent unless a lesser maximum use percentage is specified by the manufacturer. In the latter case, use the manufacturer's recommended percentage.

7.4 Stop the heating of the solvent-detergent mixture in the flash point tester at the known flash point of the dry-cleaning solvent.

### 10. Precision and Bias

10.1 This test method should have the exact precision and bias as Methods D 56 and D 92.

### 17. ASTM D 2689-88 RECOMMENDED PRACTICES FOR TESTING ALKYD RESINS

#### 13. Flash Point

13.1 In the Setaflash closed tester, a small specimen is injected by means of a syringe and its flash temperature is determined visually, as described in Test Method B of Test Method D 3278. This procedure is faster, more convenient, and somewhat more precise than the Pensky-Martens procedure described in Test Method B of Test Method D 93; however, results obtained by either test method are acceptable.

### 18. ASTM D 2833-89 INDEX OF METHODS FOR TESTING ARCHITECTURAL PAINTS AND COATINGS

NOTE—This index lists four flash point standards under "Physical Test," as follows: D 56, D 93, D 1310, and D 3278.

### 19. ASTM D 2939-78 METHOD OF TESTING EMULSIFIED BITUMENS USED AS PROTECTIVE COATINGS

#### 12. Flammability

12.1 Make the flammability test in accordance with Test Method D 92, but omit the customary heating procedure. Bring the sample to a temperature of  $32 \pm 1^\circ\text{C}$  ( $90 \pm 2^\circ\text{F}$ ) and apply the test flame. Record any tendency of the material under test to flash or ignite.

### 20. ASTM D 3065-72 (REAPPROVED 1981) TEST METHODS FOR FLAMMABILITY OF AEROSOL PRODUCTS

#### Flash Point

##### 1. Scope

1.1 These methods cover the determination of flammability hazards for aerosol products.

1.2 These test methods appear in the following order:

	Section
Flame Projection Test	4 to 7
Tag Open-Cup Flash Point Test	8 to 12
Closed Drum Test	13 to 16

### 3. Significance and Use

3.1 These methods were developed so that the Open-Drum Test could be abandoned as a meaningful guide in establishing flammability hazards.

### Tag Open-Cup Flash Point Test

#### 8. Apparatus

8.1 *Flash Tester*, described in Appendix A1 of Test Method D 1310 modified by the addition of an open vessel to contain dry ice to chill the aerosol unit.

8.2 *Shield* (see Test Method D 1310, Appendix A1).

8.3 *Thermometer*—ASTM Aniline Point Thermometer having a range from  $-36.5$  to  $+107.5^\circ\text{F}$  and conforming to the requirements for Thermometer 33°F, as prescribed in Specification E1.

#### 9. Reagents

9.1 *Bath Solution*—Brine or glycol.

9.2 *Dry Ice*.

#### 10. Conditioning

10.1 Chill the aerosol unit (filled as for use), flash cup, and bath solution to  $-32^\circ\text{C}$  ( $-25^\circ\text{F}$ ).

#### 11. Procedure

11.1 Transfer the chilled formulation to the test apparatus, and fill the cup to the conventional level, using the mechanical leveling device furnished with the apparatus.

11.2 Allow or cause the test liquid to increase in temperature at a rate of approximately  $1.1^\circ\text{C}$  ( $2^\circ\text{F}$ )/min, while passing the test flame taper across the cup at intervals of  $2^\circ\text{F}$ , until the specimen reaches  $-6.6^\circ\text{C}$  ( $+20^\circ\text{F}$ ), or until the specimen has evaporated completely.

NOTE 2—This procedure does not apply to products in which the presence of a solid portion prevents the transfer of a uniform specimen to the cup at  $-32^\circ\text{C}$  ( $-25^\circ\text{F}$ ).

#### 12. Report

12.1 The report shall include the following:

12.1.1 Product being tested, and

12.1.2 Flash point.

### 21. ASTM D 3105-85 INDEX OF METHODS FOR TESTING ELASTOMERIC AND PLASTOMERIC ROOFING AND WATERPROOFING MATERIALS

NOTE—This standard lists four flash point standards under "Physical Test," as follows: D 92, D 93, D 1310, and D 3278.

## 22. ASTM D 3143-83 (REAPPROVED 1989) TEST METHOD FOR FLASH POINT OF CUTBACK ASPHALT WITH TAG OPEN-CUP APPARATUS

### Flash Point

#### 1. Scope

1.1 This test method covers the determination of flash points by the Tag Open-Cup Apparatus of cut-back asphalts having flash points of less than 93°C (200°F).

NOTE 1—Specifications commonly designate the Cleveland Open-Cup (ASTM D 92-IP36) Method for asphalt cements and cut-back asphalts having flash points above 79°C (175°F).

NOTE 2—This procedure follows in general the procedure outlined in Test Method D 1310, but is restricted to cutback asphalt having flash points of less than 93°C (200°F).

#### 3. Summary of Test Method

3.1 The sample is placed in the cup of the tester and heated at a slow but constant rate. A small test flame is passed at a uniform rate in a level plane across the cup at specified intervals. The flash point is the lowest temperature at which application of the test flame causes the vapor at the surface of the liquid to flash.

#### 4. Significance and Use

4.1 This test method is useful in determining that an asphalt cutback has been prepared with solvents that meet the desired range of flammability, and that the product has not been contaminated with lower flash point solvents.

#### 7. Assembly and Preparation of Apparatus

7.1 Place the tester in a level position on a solid vibration-free table in a location free of draft. Shield the top of the tester from storing light so that the flash may be easily seen. Maintain a room temperature of  $25 \pm 5^\circ\text{C}$  ( $77 \pm 9^\circ\text{F}$ ) throughout the test.

7.2 Adjust the horizontal and vertical positions of the ignition taper so that the jet passes on the circumference of a circle having a radius of 6 in. (152.4 mm) and in a level plane  $\frac{1}{8}$  in. (3.2 mm) above the upper edge of the cup as measured from the center of the orifice. The jet should pass across the center of the cup at right angles to the thermometer. These adjustments should be made only when required as usually the apparatus is used continuously for a series of tests.

NOTE 3—The leveling device is used as a gage to adjust the height of the taper.

7.3 Set the draft shield around the tester so that the sides form right angles with each other and the tester is well toward the back of the shield. If the apparatus is in a draft-free hood or flash room, the shield is not required.

#### 8. Procedure

8.1 Place the glass test cup in the metal bath and adjust the thermometer holder so that the thermometer is supported firmly in a vertical position halfway between the center and edge of the cup and on a line passing through the center of the cup and the pivot of the taper. Place the thermometer so that the bottom of the bulb is  $\frac{1}{4}$  in. (6.3 mm) above the inner bottom of the cup.

8.2 Fill the metal bath with water or water-glycol solution having a temperature at least 16°C (30°F) below the probable flash point of the material to be tested. Cool tap water is satisfactory in most instances when water is used, and may be introduced into the chamber between the bath and sample cups until a slight overflow is noted at the overflow spout. The bath should be up to the overflow tube when the test cup is in place.

8.3 Rest the metal leveling device on the rim of the cup and fill the cup with material to be tested until the level just touches the pointer of the leveling device (this should be approximately  $\frac{1}{8}$  in. (3.2 mm) below the rim of the cup).

NOTE 4—The test sample should be at least 11°C (20°F) below the anticipated flash point.

8.4 Light the ignition taper and adjust the test flame to a diameter approximately the same size as the comparison bead on the apparatus but in no case greater than  $\frac{3}{32}$  in. (4 mm).

NOTE 5—Some instruments have a  $\frac{3}{32}$ -in. (4-mm) hole in the apparatus for comparison instead of the bead.

8.5 Apply heat to the bath so that the temperature of the sample rises at the rate of  $1 \pm 0.25^\circ\text{C}$  ( $2 \pm 0.5^\circ\text{F}$ )/min.

8.6 Beginning at a point  $13.8 \pm 2.8^\circ\text{C}$  ( $25 \pm 5^\circ\text{F}$ ) below the anticipated flash point, make final adjustment of the sample level in the test cup. (A syringe or medicine dropper provides a convenient means of adding or removing the sample from the cup.) At successive  $1^\circ\text{C}$  ( $2^\circ\text{F}$ ) intervals, pass the ignition taper across the sample in a continuous motion, such that the time consumed for each pass is 1 s. The first pass should be made immediately after the final adjustment of the sample level.

NOTE 6—Each pass must be made in one direction only and the taper should be kept in the "off" position at one or the other end of the swing, except when the flame is applied to the sample.

8.7 Record, as the flash point, the temperature read on the thermometer at the time the test flame application causes a distinct flash in the interior of the test cup.

#### 9. Report

9.1 Report the lowest temperature, in degrees Fahrenheit (or Celsius) at which the first initial flash is noted as the Tag Open-Cup Flash Point.

## 10. Precision

10.1 The single-operator standard deviation has been found to be 3.7°C (6.6°F). Therefore, results of two properly conducted tests by the same operator on the same asphalt should not differ by more than 10°C (18°F).

10.2 The multilaboratory standard deviation has been found to be 5.4°C (9.8°F). Therefore, results of two properly conducted tests from two different samples of the same asphalt should not differ by more than 15°C (27°F).

## 23. ASTM D 3288-82 TEST METHODS OF TESTING MAGNET-WIRE ENAMELS

### Flash Point

#### 12. Scope

12.1 This method covers the determination of the flash point of magnet-wire enamel.

#### 13. Significance

13.1 The flash point reveals the upper temperature limit to which a magnet-wire enamel may be stored or used without presenting a fire hazard.

#### 15. Procedure

15.1 Determine the flash point in accordance with Test Method D 56.

#### 16. Report

16.1 The report shall include the following:

16.1.1 Identification of magnet-wire enamel, and

16.1.2 Flash point, preferably recorded in degrees Fahrenheit.

## 24. ASTM D 3323-80 (REAPPROVED 1988)<sup>e1</sup> GUIDE FOR TESTING INTERIOR SOLVENT-THINNED FLAT WALL PAINTS

### Flash Point

6.7 *Flash Point*—When the flash point of a material is required for shipping information, use Test Methods D 3278 or D 93.

## 25. ASTM D 3425-80 (REAPPROVED 1988) GUIDE FOR TESTING SOLVENT-BASED INTERIOR SEMIGLOSS WALL AND TRIM ENAMELS

### Flash Point

6.11 *Flash Point*—Organic solvents used in enamels have characteristic temperatures at which they will support combustion. This temperature is known as the flash point. It is often used for danger classification in shipment by common

carriers. It is also used to determine conditions of storage to meet fire regulations and also the safety requirements of the OSH Act. Determine the flash point in accordance with Test Methods D 93 or D 3278.

## 26. ASTM D 3436-86 PRACTICE FOR SAMPLING AND HANDLING ANILINE

### Flammability

#### 3. Description of Product

3.1 *Typical Properties and Characteristics*

3.2 *Stability*—Aniline is a stable material under normal conditions. It does not decompose at its boiling point or when exposed to high environmental temperatures for long periods. Although the vapor given off at elevated temperatures is flammable, aniline can be handled with little danger of fire. Should aniline ignite, it may be successfully extinguished with water, applied in the form of a fog or spray.

NOTE—Table 1 of this standard lists flash points as 70.0°C (158°F) using the closed-cup method and 75.6°C (168°F) using the open-cup method. Refer to D 56, D 92, D 1310, or D 3934 for procedures.

#### 4. Hazards

4.3 *Fire:*

4.3.1 Aniline has a flash point well above room temperature. Consequently, ignition in air is difficult and the rate of flame propagation is slow. Use methods for controlling Class B fires. Fires involving aniline can be extinguished with carbon dioxide, dry chemical, and water fog. If water is used on an aniline fire in which the liquid temperature is near or above the boiling temperature of water, there will be a boil-over as a result of rapid steam formation and spattering of the aniline. This increases the toxic hazard. Therefore, in fighting large fires use fog, foam, or spray in preference to a solid stream of water.

## 27. ASTM D 3437-89 PRACTICE FOR SAMPLING AND HANDLING CYCLIC PRODUCTS

### Flammability

#### 1. Scope

1.1 This practice covers procedures for sampling and handling liquid cyclic products. These specifically cover liquids at ambient temperature and include benzene, toluene, xylenes, cyclohexane, styrene, pyridine, ethylbenzene, and isopropylbenzene.

#### 4. Description of Products

4.1 These liquids are marketed in different grades of purity so the physical properties will vary somewhat.

4.2 Benzene, toluene, xylene, cyclohexane, styrene, pyridine, and ethylbenzene are classified by the Department of Transportation as flammable liquids, and containers must bear flammable liquid labels. Trucks and tank cars must have flammable liquid placards. Isopropylbenzene is classified as a combustible liquid; trucks and tank cars must have combustible placards.

## 5. Hazards

### 5.2 Fire:

5.2.1 All of these liquids introduce a potential fire hazard where they are stored, handled, or used.

5.2.2 Vapors of all of these materials can form explosive mixtures with air.

5.2.3 Foam, carbon dioxide, dry chemical, or water fog can be used in fighting fires of these products. Special alcohol-type foam is required to extinguish effectively a fire involving pyridine.

## 28. ASTM D 3666-88 PRACTICE FOR EVALUATION OF INSPECTION AND TESTING AGENCIES FOR BITUMINOUS PAVING MATERIALS

NOTE—The laboratory test methods listed in this document are applicable to only asphaltic materials. Two ASTM flash point standards are cited as follows: D 92 and D 3143.

## 29. ASTM D 3745-78 (REAPPROVED 1989) PRACTICE FOR INSTALLATION OF PREFABRICATED ASPHALT RESERVOIR, POND, CANAL, AND DITCH LINER (EXPOSED TYPE)

NOTE—As listed in Table 1 of this Practice, the flash point of 218°C (425°F) is determined using D 92.

## 30. ASTM D 3757-89 GUIDE FOR PREPARING SPECIFICATIONS FOR SOLVENT FLOOR POLISHES

### Flash Point

8.2 *Flash Point*—Use Test Methods D 56, D 93, D 3278 or D 3828 as indicated in Note 1.

NOTE 1—For U.S. Department of Transportation's (RSPA) and U.S. Department of Labor's (OSHA) regulations use Test Method D 56 or D 3278 for liquids with a flash point of 37.8°C (100°F) and a viscosity of less than 45 SUS at 37.8°C (100°F) or 9.5 cSt at 25°C (77°F), or do not contain suspended solids or have a tendency to form a surface film while under test. Use Test Method D 93 or D 3278 for liquids having viscosities of 45 SUS or more at 37.8°C (100°F) or that contain suspended solids or have a tendency to form a surface film while under test. For Consumer Product Safety Com-

mission's regulations, use methods described in 16 CFR Chapter 11, which specifies the use of a modified Test Method D 3828, a closed-cup method.

## 31. ASTM D 3809-79 (REAPPROVED 1988) METHOD OF TESTING SYNTHETIC DIELECTRIC FLUIDS FOR CAPACITORS

### 7. Flash Point

7.1 *Significance*—The flash point of a synthetic fluid reveals the limit to which the material may be heated under the specified test conditions before the emitted vapors become a fire hazard. An unusually low flash point for a given product indicates the presence of hazardous, volatile, and combustible contaminants in the insulating liquid.

7.2 *Procedure*—Determine the flash point in accordance with Test Method D 92.

## 32. ASTM D 4277-83 (REAPPROVED 1988)<sup>e1</sup> PRACTICE FOR TESTING AMINO RESINS

### 12. Flash Point

12.1 Test Methods D 3278 provide for either a flash/no flash or finite flash point determination using the Setaflash closed tester. It is applicable only when the material to be tested has a flash point between 0 and 110°C and a viscosity lower than 150 St at 25°C.

## 33. ASTM 4712-87a GUIDE FOR TESTING OF INDUSTRIAL WATER-REDUCIBLE COATINGS

### Flash Point

9.13 *Flash Point*—Nearly all water-borne coatings are incapable of sustaining combustion, but many do contain volatile solvents whose vapors can ignite if near open flame. Because they do give flash points, water-borne coatings must be tested for flash point temperature to conform with many government regulations concerning transportation, labeling, packaging, etc. Determine flash point in accordance with Test Methods D 56, D 93 or D 3278.

## 34. ASTM D 4733-87 TEST METHODS FOR SOLVENTLESS ELECTRICAL INSULATING VARNISHES

### 8. Flash Point

8.1 *Scope*—This test method covers the determination of the flash point of solventless varnishes. There are two types of material involved:

8.1.1 Those varnishes having a flash point above 110°C (230°F), and

8.1.2 Those varnishes having a flash point below 110°C (230°F).

8.2 *Summary of Test Method*—A specified amount of sample is added to the instrument. The temperature of the material is increased at a constant rate until a small flame ignites the vapor of the specimen in the tester and propagates a flame across its surface. The temperature at ignition is taken as the flash point.

8.4 *Procedure:*

8.4.1 Test the materials of 8.1.1 in accordance with Test Methods D 56, D 93, and D 3278.

8.4.2 Test the materials of 8.1.2 in accordance with Test Method D 3278.

### 35. ASTM E 502-84 (REAPPROVED 1989) TEST METHOD FOR SELECTION AND USE OF ASTM STANDARDS FOR THE DETERMINATION OF FLASH POINT OF CHEMICALS BY CLOSED CUP METHODS

#### 1. Scope

1.1 This test method covers the determination of the flash point of liquid and solid chemical compounds flashing from below -10 to 370°C (16 to 700°F). The procedures and apparatus in Test Methods D 56, D 93, D 3278, D 3828, and D 3941 are to be used. Modification to these procedures are specified for tests on solids and viscous liquids. The significance of the results obtained is discussed along with possible sources of error and factors that might cause interference.

#### 2. Referenced Documents

2.1 *ASTM Standards:*

- D 56 Test Method for Flash Point by Tag Closed Tester
- D 92 Test Method for Flash and Fire Points by Cleveland Open Cup
- D 93 Test Methods for Flash Point by Pensky-Martens Closed Tester
- D 1310 Test Method for Flash Point and Fire Points of Liquids by Tag Open-Cup Apparatus
- D 3278 Test Method for Flash Point of Liquids by Setaflash Closed Tester
- D 3828 Test Method for Flash Point by Setaflash Closed Tester
- D 3934 Test Method for Flash/No Flash Test Equilibrium Method by a Closed-Cup Apparatus
- D 3941 Test Method for Flash Point by the Equilibrium Method with a Closed-Cup Apparatus
- E 681 Test Method for Limits of Flammability of Chemicals

#### 5. Significance and Use

5.1 The flash point measures the response of the sample to heat and flame under controlled laboratory conditions. It is only one of a number of properties that must be considered in assessing the overall flammability hazard of a material.

5.2 As a result of physical factors inherent in the apparatus and procedure, the closed cup flash point does not necessarily represent the minimum temperature at which a material can evolve flammable vapors, and the absence of a flash point does not guarantee nonflammability (see Appendix X1 and X2).

5.3 Flash point is used in shipping and safety regulations to define flammable and combustible materials. Test Methods D 56, D 93, and D 3278 are specified as test methods for determining the flash point of these materials.

5.4 Setaflash methods involving equilibrium procedures and only one flame pass per specimen are preferred.

#### 12. Procedure

12.1 Follow the procedures outlined in Test Methods D 56 or D 3941 (Tag Closed Cup), D 3278 or D 3827 (Setaflash Closed Cup), and D 93 (Pensky Martens Closed Cup), as is necessary. Certain explanatory notes and procedure modifications not contained in the individual methods are given in this method. Occasionally, particularly near the temperature of the actual flash point, the application of the test flame will cause a halo or test flame enlargement that should be ignored. In some cases this test flame enlargement will not lead to a flash point on an increase in temperature.

NOTE—The reader should consult the entire standard for information concerning when specific test methods that should be used, possible interferences in conducting the methods, hazards involved in conducting flash point on certain types of chemicals, and procedures to minimize hazards. This standard also contains commentaries on the flash point test and the flammability of mixtures.

### 36. ASTM E 752-82 SAFETY AND HEALTH REQUIREMENTS RELATING TO OCCUPATIONAL EXPOSURE TO CARBON DISULFIDE

#### Introduction

Carbon disulfide (synonym: carbon bisulfide) is a volatile and colorless to slightly yellowish liquid. In a pure state, carbon disulfide may have an odor similar to ether or chloroform. In a commercial grade, it has a pungent odor similar to that of decaying cabbage. Carbon disulfide is considered highly flammable with an explosive range from 1.00 to 50.0% by volume in air.

#### 1. Scope

1.1 This practice is designed to help protect the safety and health of employees working with carbon disulfide.

1.2 This practice is primarily intended for industries where carbon disulfide is present in the workplace. Every effort should be made to limit exposure of any employee to airborne concentrations of the method.

5.7.1.2 *Fire Protection*—Carbon disulfide has a closed-cup flash point of -30°C (-22°F). It may be easily ignited by an ordinary filament lamp or unprotected steam line.

Smoking shall be prohibited in areas where carbon disulfide vapors could occur. Precautions shall be taken to avoid any possibility of liquid or vapor contact with sources of heat, flame, or static sparks. For fire fighting, self-contained breathing equipment must be used. Carbon disulfide fires are best extinguished by the use of water fog or a fine water spray. Fires shall be completely blanketed with water to extinguish the flame and to cool down the surrounding equipment. Fire hydrants and hoses equipped with variable-

spray or fog nozzles shall be located within a reasonable distance from and on all sides of any facility handling carbon disulfide. Chemical foam, carbon dioxide, and dry powder fire extinguishers are suitable for use on small, well-contained carbon disulfide fires. Carbon dioxide extinguishers shall be fitted with conductive discharge horns to avoid static accumulations. Other precautions for a Class I flammable liquid, Class B fire, and "extra hazard" can be found in NFPA 30 Code for Flammable and Combustible Liquids.

## 4

# ASTM Specifications with Flash Point Requirements (Excerpts)

## INTRODUCTION

The following standard specifications have a flash or fire point requirement. The specifications may require a flash point measurement for several reasons, such as, determining classification for government regulations or preventing sale or use of materials that contain diluents. For example, these diluents may be solvent in refined drying oils or fuels in lubricating oils.

In addition, flash points may help determine suitability of a hydrocarbon blend for fuels.

The section of each specification referring to flash or fire point properties and the test method specified are also listed.

NOTE—All flash point standards referenced herein are included in this manual as part of Chapter 2.

### 1. ASTM D 12-88 RAW TUNG OIL

NOTE—Table 1 of this specification lists the minimum flash point at 95°C (203°F) using D 3278 or 121°C (250°F) using D 93.

### 2. ASTM D 234-82 (REAPPROVED 1987) RAW LINSEED OIL.

NOTE—Table 1 of this specification lists the minimum flash point at 121°C (250°F) using D 93.

TABLE 4-1—Quick reference to ASTM Specifications that cite flash point requirements.

ASTM Specification/BOS Volume	Flash Point Standard Cited	Section Citing Flash Point
D 12-88/06.03	D 93, D 3278	3.1
D 234-82(1987)/06.03	D 93	3.1
D 235-87/05.01,06.03	D 56, D 3278	3.1
D 312-84/04.04	D 92	5.1
D 396-89a/05.01	D 56, D 93	5.1
D 449-79(1983)/04.04	D 92	6.1
D 450-78(1984)/04.04	D 92	6.1
D 946-82/04.03	D 92	5.1
D 1227-87/04.04	D 92	5.1
D 1655-89/05.01, D 1786-90/08.02	D 56, D 3828	4.1, 10.1
D 1859-71(1986)/04.09	D 93	3.1, 4.1
D 2026-72(1985)/04.03	D 92	4.1
D 2027-76(1986)/04.03	D 1310	4.1
D 2028-76(1986)/04.03	D 1310	4.1
D 2233-86/10.03	D 92	5.1
D 2283-86/10.03	D 92	4.1
D 2521-76(1981)/04.04	D 92	4.1
D 2604-86/04.09	D 93	3.1, 4.1
D 2762-70(1989)/15.04	D 56, D 92	4.7
D 2763-70(1989)/15.04	D 56, D 92	5.5
D 2880-89/05.02	D 56, D 93	6.1
D 3141-80(1986)/04.03	D 92	5.1
D 3225-73(1984)/04.09	D 56	3.1, 4.1, 5.1
D 3320-79(1984)/04.04	D 92	6.9
D 3487-88/10.03	D 92	5.1
D 3699-88/05.03	D 56, D 3828	5.2
D 3734-87/06.03	D 56, D 3278	3.1, 6.1
D 3735-87/06.03	D 56, D 3278	3.1, 6.1
D 3757-89/15.04	D 56, D 93, D 3278, D 3828	6.1, 8.2
D 3955-86/10.01	D 56	4.7
D 4010-83/15.04	D 3941, D 3278	3.1, 6.1
D 4011-81(1986)/15.04	D 93, D 3278	5.1
D 4022-81/04.04	D 1310	5.5, 7.6
D 4293-83/05.03	D 92	3.2, 5.2, 5.3
D 4304-84/05.03	D 92	5.1

**3. ASTM D 235-87 MINERAL SPIRITS  
(PETROLEUM SPIRITS)  
(HYDROCARBON DRY  
CLEANING SOLVENT)**

**3. Classification**

3.1 Mineral spirits shall be of the following types as specified:

- 3.1.1 *Type I*—Regular (Stoddard Solvent)
- 3.1.2 *Type II*—High Flash Point
- 3.1.3 *Type III*—Odorless
- 3.1.4 *Type IV*—Low Dry Point

**6. Test Methods**

6.1.5 *Flash Point*—Test method D 56 or Test Methods D 3278. In case of dispute, Test Method D 56 shall be the referee method.

NOTE—Table 1 of this specification lists flash point requirements for the different types of mineral spirits as follows:

Physical and Chemical Properties of Mineral Spirits—  
Specification D 235

	Type I	Type II	Type III	Type IV
Commercial Reference	regular mineral spirits (Stoddard solvent)	high flash point	odorless	low dry point
Flash point, min, °C(°F)	38 (100)	60(140)	38(100)	38(100)

**4. ASTM D 312-89 ASPHALT USED IN ROOFING**

NOTE—The types of asphalt along with their slope guidelines are listed in the Appendix of this specification as follows:

**Slope Guidelines**

*Type I* includes asphalts that are relatively susceptible to flow at roof temperatures with good adhesive and “self-healing” properties. They are generally used in slag- or gravel-surfaced roofs on inclines up to 4.17 % (½ in./ft) slope.

*Type II* includes asphalts that are moderately susceptible to flow at roof temperatures. They are generally for use in built-up roof construction on inclines from approximately 4.17 % (½ in./ft) slope to 12.5 % (1½ in./ft) slopes.

*Type III* includes asphalts that are relatively nonsusceptible to flow at roof temperatures for use in the construction of built-up roof construction on inclines from approximately 8.3 % (1 in./ft) slope to 25 % (3 in./ft) slope.

*Type IV* includes asphalts that are generally nonsusceptible to flow at roof temperatures for use in the construction of built-up roofing on inclines from approximately 16.7 % (2 in./ft) slope to 50 % (6 in./ft) slope. These asphalts may

be useful in areas where relatively high year-round temperatures are experienced.

All four types have minimum flash points of 246°C (475°F) as listed in Table 1 of this specification.

**5. Sampling and Test Methods**

5.1 Sample the material and determine the properties enumerated in this specification in accordance with the following methods:

- 5.1.3 *Flash Point*—Test Method D 92.

**5. ASTM D 396-89a FUEL OILS**

5.1.1 *Flash Point*—Test methods D 93, except where other methods are prescribed by law for the determination of minimum flash point. For Grades No. 1 and No. 2, Test Method D 56, may be used as an alternative with the same limits, provided the flash point is below 79.4°C (175°F) and the viscosity is below 5.8 cSt (45 SUS) at 38°C (100°F). This method will give slightly lower values. In cases of dispute, Test Methods D 93 shall be used as the referee method.

NOTE—The significance of Test methods and the grades of fuel oils are described in the Appendix of this specification as follows:

**Significance of Test Methods**

The significance of the flash point of fuel oil on which limitations are placed by the specification is as follows:

The flash point of a fuel oil is an indication of the maximum temperature at which it can be stored and handled without serious fire hazard. The minimum permissible flash point is usually regulated by federal, state, or municipal laws and is based on accepted practice in handling and use.

**Grades**

*Grade No. 1* is a light distillate intended for use in burners of the vaporizing type in which the oil is converted to a vapor by contact with a heated surface or by radiation. High volatility is necessary to ensure that evaporation proceeds with a minimum of residue.

*Grade No. 2* is a heavier distillate than grade No. 1. It is intended for use in atomizing type burners which spray the oil into a combustion chamber where the tiny droplets burn while in suspension. This grade of oil is used in most domestic burners and in many medium capacity commercial-industrial burners where its ease of handling and ready availability sometimes justify its higher cost over the residual fuels.

*Grade No. 4 (Light)* is a heavy distillate fuel or distillate/residual fuel blend meeting the specification viscosity range. It is intended for use both in pressure-atomizing commercial-industrial burners not requiring higher cost distillates and in burners equipped to atomize oils of higher viscosity. Its permissible viscosity range allows it to be pumped and atomized at relatively low storage temperatures.



Grade No. 4 is usually a heavy distillate/residual fuel blend but may be a heavy distillate fuel meeting the specification viscosity range. It is intended for use in burners equipped with devices that atomize oils of higher viscosity than domestic burners can handle. Its permissible viscosity range allows it to be pumped and atomized at relatively low storage temperatures. Thus, in all but extremely cold weather, it requires no preheating for handling.

Grade No. 5 (Light) is residual fuel of intermediate viscosity for burners capable of handling fuel more viscous than grade No. 4 without preheating. Preheating may be necessary in some types of equipment for burning and in colder climates for handling.

Grade No. 5 (Heavy) is a residual fuel more viscous than Grade No. 5 (light) and is intended for use in similar service. Preheating may be necessary in some types of equipment for burning and in colder climates for handling.

Grade No. 6, sometimes referred to as "Bunker C," is a high-viscosity oil used mostly in commercial and industrial heating. It requires preheating in the storage tank to permit pumping, and additional preheating at the burner to permit atomizing. The extra equipment and maintenance required to handle this fuel usually precludes its use in small installations.

As listed in Table 1 of this specification, No. 1, 2, and 4 light grades of fuel oil have minimum flash points of 38°C (100°F); No. 4, 5 light, and 5 heavy oils have minimum flash points of 55°C (130°F); and No. 6 oil has a minimum flash point of 60°C (140°F).

## 6. ASTM D 449-79 (REAPPROVED 1983) ASPHALT USED FOR DAMPROOFING AND WATERPROOFING

### 3. Classification

3.1 Asphalts covered by this specification include three types:

3.1.1 *Type I*—A soft, adhesive, "self-healing" asphalt that flows easily under the mop and is suitable for use below grade under uniformly moderate temperature conditions both during the process of installation and during service.

NOTE—Type I asphalt is suitable for foundations, tunnels, subways, etc.

3.1.2 *Type II*—A somewhat less susceptible asphalt than Type I, with good adhesive and "self-healing" properties, suitable for use above grade where it will not be exposed to temperatures exceeding 50°C (122°F).

NOTE—Type II asphalt is suitable for railroad bridges, culverts, retaining walls, tanks, dams, conduits, spray decks, etc.

3.1.3 *Type III*—An asphalt less susceptible to temperature than Type II, with good adhesive properties, and suitable for use above grade on vertical surfaces exposed to direct sunlight or temperatures above 50°C (122°F).

## 6. Sampling and Test Methods

6.1 Sample the material and determine the properties enumerated in this specification in accordance with the following methods:

6.1.3 Determine the *Flash Point*—Test Method D 92.

NOTE—Table 1 of this specification lists the flash points of the asphalt types as follows:

	Type I min	Type II min	Type III min
Flash point (Cleveland open-cup), °C (°F)	175 (347)	200 (392)	205 (401)

## 7. ASTM D 450-78 (REAPPROVED 1984) COAL-TAR PITCH USED IN ROOFING, DAMPROOFING, AND WATERPROOFING

### 3. Classification

3.1 Coal-tar pitches covered by this specification include three types:

3.1.1 *Type I*—Suitable for use in built-up roofing systems with felts conforming to the requirements of Specification D 227 or as specified by the manufacturer.

3.1.2 *Type II*—Suitable for use in dampproofing and in membrane waterproofing systems, with primers conforming to the requirements of Specification D 43, felts conforming to the requirements of Specification D 227, and fabrics with coal-tar saturant conforming to the requirements of Specifications D 173, D 1327, or D 1668 or in systems using any combination of components specified by the manufacturer.

3.1.3 *Type III*—Suitable for use in built-up roofing systems, but having less volatile components than Type I.

NOTE—All three types have minimum Cleveland open-cup flash points of 120°C (248°F) as listed in Table 1 of this specification.

## 6. Sampling and Test Methods

6.1 Sample the material and determine the properties enumerated in this specification in accordance with the following methods.

6.1.5 *Flash Point*—Test Method D 92.

## 8. ASTM D 946-82 PENETRATION-GRADED ASPHALT CEMENT FOR USE IN PAVEMENT CONSTRUCTION

### 5. Methods of Sampling and Testing

5.1 The material shall be sampled and the properties enumerated in this specification shall be determined in accordance with the following ASTM methods:

5.1.3 Flash Point—Test Method D 92.

NOTE—As listed in Table 1 of this specification, the flash points for the different penetration grades of asphalt cement are as follows:

	Requirements for Asphalt Cement for Use in Pavement Construction—Specification D 946				
	Penetration Grade				
	40–50	60–70	85–100	120–150	200–300
	min	min	min	min	min
Flash point, Cleveland open-cup °C (°F)	232 (450)	232 (450)	232 (450)	218 (425)	177 (350)

9. ASTM D 1227-87 EMULSIFIED ASPHALT USED AS A PROTECTIVE COATING

3. Classification

3.1 Type I—Emulsified asphalt prepared with mineral colloid emulsifying agents and containing asbestos fibers.

3.2 Type II—Emulsified asphalt prepared with chemical emulsifying agents and containing mineral fillers.

3.3 Type III—Emulsified asphalt prepared with mineral colloid emulsifying agents, without fibrous reinforcement.

3.4 Type IV—Emulsified asphalt prepared with mineral colloid emulsifying agents and containing fibers other than asbestos.

NOTE—None of the 4 types of emulsified asphalts in this specification has a tendency to flash or ignite.

5. Sampling and Test Methods

5.1 Sample the material and determine compliance with these specifications in accordance with ASTM Test Method D 2939 which specifies Test Method D 92.

10. ASTM D 1655-89 AVIATION TURBINE FUELS

4. Types

4.1 Three types of aviation turbine fuels are provided, as follows:

4.1.1 Jet A and Jet A-1—A relatively high flash point distillate of the kerosine type.

4.1.2 Jet B—A relatively wide boiling range volatile distillate

4.2 Jet A and Jet A-1 represent two grades of kerosine fuel that differ in freezing point. Other grades would be suitably identified.

NOTE—As listed in Table 1 of this specification, the minimum flash point of Jet A and Jet A-1 fuels is 38°C (100°F) in accordance with ASTM methods D 56 and D 3828. There is no flash point listed for Jet B fuel. Results obtained by D

3828 may be up to 2°C (3°F) below those obtained by D 56 which is the preferred method. In case of dispute, D 56 will apply.

10. Test Methods

10.1 Determine the requirements enumerated in this specification in accordance with the following ASTM test methods:

10.1.4 Flash Point—Test Method D 56 or D 3828.

NOTE—Flash point is also described in the Fuel Cleanliness and Handling section of Appendix X1 of this Specification as follows:

Flash Point—The flash point is an indication of the maximum temperature for fuel handling and storage without serious fire hazard. The shipment, storage and handling precautions regulated by municipal, state, or federal laws and insurance requirements, are a function of the flash point for the particular fuel being utilized.

11. ASTM D 1786-90 TOLUENE DIISOCYANATE

3. Classification

3.1 This specification covers three classes of toluene diisocyanates, based on isomer ratio, and three types based on acidity and hydrolyzable chloride.

3.2 Each class may be subdivided into three types on the basis of acidity differences as follows:

3.2.1 Type I or A—Acidity shall be between 0.0015 and 0.0045 determined as percent HCl. Hydrolyzable chloride shall be less than 0.01 %.

Detail Requirements for Toluene Diisocyanate

	Class		
	100	80	65
Isomer ratio, 2, 4 isomer, %	97.5 min	80 ± 2	65 ± 2
Purity, min, %	99.5	99.5	99.5
APHA color, max	50	50	50
Total chlorine, max, %	0.2	0.1	0.2

3.2.2 Type II or B—Acidity shall be between 0.0070 and 0.012 as percent HCl. Hydrolyzable chloride shall be less than 0.015 %.

3.2.3 Type III or C—Acidity shall be greater than 0.012 as percent HCl. Hydrolyzable chloride limits may be set at the convenience of the supplier and purchaser.

4. Requirements

4.1 These materials shall conform to the requirements prescribed in Table 1.

## 5. Sampling and Test Methods

5.1 The materials shall be sampled and tested in accordance with Methods D 1638.

## 6. Retest and Rejection

6.1 If any failure occurs, the material may be retested to establish conformity in accordance with agreement between the purchaser and the seller.

## 12. ASTM D 1859-71 (REAPPROVED 1986) PETROLEUM FOR BLENDING WITH CREOSOTE

### 3. Properties

3.1 Petroleum for blending with creosote shall conform to the following minimum flash point requirement: 79°C (175°F)

### 4. Sampling and Test Methods

4.1 Determine the sampling and properties enumerated in this specification in accordance with the following ASTM methods:

4.1.4 *Flash Point*—Test Method D 93.

## 13. ASTM D 2026-72 (REAPPROVED 1985) CUTBACK ASPHALT (SLOW CURING TYPE)

### 4. Test Methods

4.1 The material shall be sampled in accordance with Method D 140, and the properties enumerated in this specification shall be determined in accordance with the following ASTM methods:

4.1.1 *Flash Point (Cleveland Open-Cup)*—Method D 92.

NOTE—As listed in Table 1 of this specification, the flash points for the different cutback asphalts are as follows:

Designation	SC-70	SC-250	SC-800	SC-3000
Minimum flash point (Cleveland open- cup), °C (°F)	66 (150)	79 (175)	93 (200)	107 (225)

## 14. ASTM D 2027-76 (REAPPROVED 1986) CUTBACK ASPHALT (MEDIUM-CURING TYPE)

### 4. Test Methods

4.1 The material shall be sampled in accordance with Method D 140, and the properties enumerated in this spec-

ification shall be determined in accordance with the following ASTM Methods:

4.1.1 *Flash Point Tag Open-Cup*—Method D 3143. (See Test Method 1310 for details of the Tag open-cup apparatus.)

NOTE—As listed in Table 1 of this specification, the flash point for the different cut back asphalts are as follows:

Designation	MC-30	MC-70	MC-250	MC-800	MC-3000
Minimum flash point Tag open-cup, °C (°F)	38 (100)	38 (100)	66 (150)	66 (150)	66 (150)

## 15. ASTM D 2028-76 (REAPPROVED 1986) CUTBACK ASPHALT (RAPID-CURING TYPE)

### 4. Test Methods

4.1 The material shall be sampled in accordance with Methods D 140, and the properties enumerated in this specification shall be determined in accordance with the following ASTM methods:

4.1.1 *Flash Point Tag Open-Cup*—Method D 3143. (See Test Method D 1310 for details of the Tag Open-Cup apparatus.)

NOTE—As listed in Table 1 of this specification, the minimum flash point for all rapid-curing types of cutback asphalt is 27 + °C (80 + °F).

## 16. ASTM D 2233-86 CHLORINATED AROMATIC HYDROCARBONS (ASKARELS) FOR CAPACITATORS

### 1. Scope

1.3 Askarels covered by this specification are of four types as follows:

1.3.1 *Type A*—Biphenyl that has been chlorinated to a content of 42 weight %.

1.3.2 *Type B*—Biphenyl that has been chlorinated to a chlorine content of 54 weight %.

1.3.3 *Type C*—A mixture of approximately 75 % Type B and 25 % trichlorobenzene.

1.3.4 *Type D*—The same as Type A, except that the higher boiling homologs have been removed to a maximum level of 0.4 %.

NOTE—As listed in Table 1 of this specification, the fire point of all four types of askarels is “none to boiling,” according to Test Method D 92. When testing for fire point, pseudo-flash may be observed; it differs noticeably from the flash obtained on combustible materials and is not indicative of a fire hazard.

TABLE 1—Askarels Components in Weight Percent—Specification D 2283.

Components	Type A	Type B	Type C	Type D	Type E	Type F	Type G	Type H
Hexachlorobiphenyl <sup>A</sup>	60	45						
Pentachlorobiphenyl <sup>B</sup>				70		45	60	
Trichlorobiphenyl <sup>C</sup>			80		100			
Trichlorobenzene <sup>D</sup>	40			30			40	
Tri-tetra blend <sup>E</sup>		55	20			55		100
Phenoxypropene oxide <sup>F</sup>	0.18 to 0.22			0.18 to 0.22	0.18 to 0.22			
Diepoxide-type compound <sup>G</sup>		0.115 to 0.135	0.115 to 0.135			0.115 to 0.135	0.115 to 0.135	0.10 to 0.125

<sup>A</sup>Biphenyl chlorinated to a chlorine content of 60 weight %.

<sup>B</sup>Biphenyl chlorinated to a chlorine content of 54 weight %.

<sup>C</sup>Biphenyl chlorinated to a chlorine content of 42 weight %.

<sup>D</sup>A mixture of isomers of trichlorobenzene.

<sup>E</sup>A mixture of isomers of trichlorobenzene and tetrachlorobenzene.

<sup>F</sup>Glycidyl-phenyl ether.

<sup>G</sup>3,4-Epoxy-cyclohexylmethyl-3,4-epoxy-cyclohexane carboxylate.

<sup>H</sup>Non-PCB contains no chlorinated biphenyls.

**17. ASTM D 2283-86 CHLORINATED AROMATIC HYDROCARBONS (ASKARELS) FOR TRANSFORMERS**

**1. Scope**

1.2 Askarels covered by this specification are of various types, having components in weight percent in accordance with Table 1.

NOTE 1—The components and the respective percentages given are descriptive of the materials currently in common use and are not intended as part of this specification.

NOTE 2—Types A through G are PCB-type askarels previously available and still in use in the field. Recently Type H, a non-PCB askarel, was introduced as a retrofit and replacement.

NOTE 3—Current governmental regulations prohibit the manufacture and sale of polychlorinated biphenyls (PCBs). This specification serves as a reference for all askarels, PCB and non-PCB.

NOTE—As listed in Table 1 of this specification, the fire point of all eight askarels is “none to boiling,” according to ASTM Test Method D 92. <sup>A</sup>When testing for fire point, a pseudo-flash may be observed; it differs noticeably from the flash obtained from combustible materials and is not indicative of a fire hazard.

**18. ASTM D 2521-76 (REAPPROVED 1981) ASPHALT USED IN CANAL, DITCH AND POND LINING**

**4. Sampling and Test Methods**

4.1 Sample the material and determine the properties enumerated in this specification in accordance with the following methods:

4.1.5 *Flash Point*—Method D 92.

NOTE—As listed in Table 1 of this specification, the minimum flash point (Cleveland open-cup) for this asphalt is 218°C (425°F).

**19. ASTM D 2604-86 HIGH-BOILING HYDROCARBON SOLVENT FOR PREPARING OIL-BORNE PRESERVATIVE SOLUTIONS**

**3. Properties**

3.1 High-boiling hydrocarbon solvent for preparing oil-borne preservative solutions shall conform to the following minimum flash point requirement using the Pensky-Martens closed tester: 65.6°C (150°F).

**4. Test Methods**

4.1 The material shall be sampled and the properties enumerated in this specification shall be determined in accordance with the following ASTM methods:

4.1.4 *Flash Point*—Method D 93.

**20. ASTM D 2762-70 (REAPPROVED 1989) DRYCLEANING DETERGENT, NON-CHARGE TYPE**

**4. General Requirements**

4.7 The flash point of the detergent dissolved at normal use concentrations in drycleaning solvent shall be not lower than the flash point of the drycleaning solvent itself. Determination shall be made in accordance with ASTM Test Method D 2554, Test for Flash Point of Drycleaning Detergents in the Drycleaning Bath. Method D 2554 specifies flash point methods D 56 and D 92.

**21. ASTM D 2763-70 (REAPPROVED 1989) DRYCLEANING DETERGENT, LIQUID CHARGE TYPE**

5.5 The flash point of a 4 percent solution of the detergent dissolved in drycleaning solvent shall be not lower than the flash point of the drycleaning solvent itself. Determination shall be made in accordance with ASTM Test Method D 2554, Test for Flash Point of Drycleaning Detergents in

the Drycleaning Bath. Method D 2554 specifies flash point methods D 56 and D 92.

## 22. ASTM D 2880-89 GAS TURBINE FUEL OILS

NOTE—The grades of gas turbine fuel oils are listed in Appendix X1 of this specification as follows:

*Grade 0-GT*—Includes naphtha, Jet B, and other light hydrocarbon liquids that characteristically have low flash point and low viscosity as compared with kerosine and fuel oils.

*Grade 1-GT*—Is a light distillate fuel oil suitable for use in nearly all gas turbines.

*Grade 2-GT*—Which is a heavier distillate than Grade 1-GT, can be used by gas turbines not requiring the clean burning characteristics of Grade 1-GT. Fuel heating equipment may be required by the gas turbine depending on the fuel system design or ambient temperature conditions, or both.

*Grade 3-GT*—May be a heavier distillate than Grade 2-GT, a residual fuel oil that meets the low ash requirements, or a blend of distillate with a residual fuel oil. Fuel heating will be required by the gas turbine in almost every installation.

*Grade 4-GT*—Includes most residuals and some topped crudes. Because of the wide variation and lack of control of properties, the gas turbine manufacturer should be consulted with regard to acceptable limits or properties.

NOTE—Fuels prepared to different specifications and sold under different names may meet the requirements of fuels specified under Specification D 2880. However, specification tests would normally have to be run to ensure compliance with the requirements of Specification D 2880 as other fuels are not necessarily interchangeable with D 2880 fuels throughout the range permitted by the other specifications.

### 6. Test Methods

6.1 The requirements enumerated in this specification shall be determined in accordance with the following ASTM methods except as noted:

6.1.1 *Flash Point*—Test Methods D 93, except where other methods are prescribed by law for the determination of minimum flash point. For Grade Nos. 1-GT and 2-GT, Method D 56 may be used along with other mutually acceptable methods, as an alternative with the same limits provided the flash point is below 93°C (200°F). This method will give slightly lower values. In case of dispute, Test Methods D 93 shall be used as the referee method.

As listed in Table 1 of this specification, Nos. 1-GT and 2-GT oils have minimum flash points of 38°C (100°F); No. 3-GT has a minimum flash point of 55°C (130°F); and No. 4-GT oil has a minimum flash point of 66°C (150°F). For No. 0-GT oil, when flash point is below 38°C (100°F), or when kinematic viscosity is below 7.3cSt at 40°C (104°F), or when both conditions exist, the turbine manufacturer should be consulted with respect to safe handling and fuel system design.

NOTE—The **Significance of Test Methods** section in Appendix 1 of this specification lists the following for flash point:

*Flash Point* is an indication of the maximum temperature at which a fuel oil can be stored and handled without serious fire hazard. The minimum permissible flash point is usually regulated by federal, state, or municipal laws and is based on accepted practice in handling and use.

## 23. ASTM D 3141-80 (REAPPROVED 1986) ASPHALT FOR UNDERSEALING PORTLAND CEMENT CONCRETE PAVEMENTS

### 5. Methods of Sampling and Testing

5.1 The asphalt shall be sampled and the properties enumerated in this specification shall be determined in accordance with the following ASTM methods:

5.1.3 *Flash Point*—Test Method D 92.

NOTE—As listed in Table 1 of this specification, the minimum flash point for this asphalt is 225°C (437°F) and is the same as for Type III asphalt in Specification D 312.

## 24. ASTM D 3225-73 (REAPPROVED 1984) LOW BOILING HYDROCARBON SOLVENT FOR OIL-BORNE PRESERVATIVES

### 5. Test Methods

5.1 The sampling and requirements enumerated in this specification shall be determined in accordance with the following ASTM methods:

*Flash Point*—Test Method D 56.

An auxiliary or co-solvent shall be used with the low-boiling hydrocarbon solvent and pentachlorophenol. The combination of the auxiliary solvent and low-boiling hydrocarbon solvent shall have a flash point requirement of 27°C (80°F) in accordance with section 4.1 of this specification.

NOTE—Hydrocarbon solvent for preparing solutions of pentachlorophenol shall conform to the flash point requirement of 27°C (80°F) in accordance with Section 3.1 of this specification.

## 25. ASTM D 3320-79 (REAPPROVED 1984) EMULSIFIED COAL-TAR PITCH (MINERAL COLLOID TYPE)

### 4. Physical Requirements

4.4 The material shall conform to the flash point prescribed below prior to fortification with antifreeze.

## 6. Test Methods

6.9 *Flammability*—Test Method D 2939, Section 12. Test Method D 2939 specifies a modified Test Method D 92 for flash point.

NOTE—As listed in Table 1 of this specification, this coal-tar pitch shows no tendency to flash or ignite.

## 26. ASTM D 3487-88 MINERAL INSULATING OIL USED IN ELECTRICAL APPARATUS

### 3. Definitions

3.1 *Type I Mineral Oil*—an oil for apparatus where normal oxidation resistance is required. Some oils may require the addition of a suitable oxidation inhibitor to achieve this.

3.2 *Type II Mineral Oil*—an oil for apparatus where greater oxidation resistance is required. This is usually achieved with the addition of a suitable oxidation inhibitor.

### 5. Property Requirements

5.1 Mineral insulating oil conforming to this specification shall meet the minimum flash point limits shown in Table 1 as 145°C (293°F), as cited in ASTM flash point Method D 92.

NOTE—The safe operation of the apparatus requires an adequately high flash point, as stated in Appendix 2 of this specification.

## 27. ASTM D 3699-88 KEROSENE

### 5. Test Methods

5.2 The flash point requirement prescribed in this specification is D 56 or D 3828, with Method D 56 designated the referee method in disputes.

NOTE—As listed in Table 1 of this specification, the minimum flash point for kerosene is 38°C (100°F). Appendix 1 also lists the significance of standard flash point specifications for kerosene in Section 1.6 as: the flash point of kerosene is used primarily as an index of fire hazards. The minimum permissible flash point is usually regulated by federal, state, or municipal laws and is based on accepted practice in handling and use.

## 28. ASTM D 3734-87 HIGH-FLASH AROMATIC NAPHTHAS

### 1. Scope

1.1 This specification covers two types of aromatic hydrocarbon solvents, normally petroleum distillates, having high flash points, moderately low volatility, and a distillation range of approximately 28°C (50°F). These solvents are used primarily by the coatings industry and are commonly referred to as high-flash aromatic naphthas.

### 3. Classification

3.1 High-flash aromatic naphthas shall be of the following types, as specified:

3.2 *Type I*—Aromatic 100, having a flash point not less than 38°C (100°F).

3.3 *Type II*—Aromatic 150, having a flash point typically of 66°C (150°F), but not less than 60°C (140°F).

### 6. Test Methods

6.1 The properties enumerated in this specification shall be determined in accordance with the following ASTM test methods:

6.1.5 *Flash Point*—Test Methods D 56, D 3278 (alternative).

## 29. ASTM D 3735-87 VM&P NAPHTHAS

### 1. Scope

1.1 This specification covers three types of moderately volatile hydrocarbon solvents, mainly aliphatic in composition and normally petroleum distillates. These solvents are used primarily by the coatings industry and are commonly referred to as VM&P naphthas.

### 3. Classification

3.1 VM&P naphthas shall be of the following types, as specified:

3.1.1 *Type I*—Regular.

3.1.2 *Type II*—High flash

3.1.3 *Type III*—Odorless

### 6. Test Methods

6.1 The properties enumerated in this specification shall be determined in accordance with the following ASTM test methods:

6.1.6 *Flash Point*—Test Methods D 56, D 3278 (alternative). In case of dispute, Test Method D 56 is controlling.

NOTE—As listed in Table 1 of this specification, the minimum flash points for VM&P Naphthas are 4°C (40°F) for Types I and III, and 27°C (80°F) for Type II.

## 30. ASTM D 3757-89 GUIDE FOR PREPARING SPECIFICATIONS FOR SOLVENT FLOOR POLISHES

6.1.2 *Flash Point*—The flash point of liquid products shall be greater than ( ) when determined in accordance with the methods listed under Test Methods.

### 8. Test Methods

8.2 *Flash Point*—Use Test Methods D 56, D 93, D 3278 or D 3828 as indicated in NOTE below.

NOTE—For U.S. Department of Transportation’s (RSPA) and U.S. Department of Labor’s (OSHA) regulations use Test Method D 56 or D 3278 for liquids with a flash point of 37.8°C (100°F) and a viscosity of less than 45 SUS at 37.8°C (100°F) or 9.5 cSt at 25°C (77°F), or do not contain suspended solids or have a tendency to form a surface film while under test. Use Test Method D 93 or D 3278 for liquids having viscosities of 45 SUS or more at 37.8°C (100°F) or that contain suspended solids or have a tendency to form a surface film while under test. For Consumer Product Safety Commission’s regulations, use methods described in 16 CFR Chapter 11, which specifies the use of a modified Test Method D 3828, a closed-cup method. These regulations are available from Superintendent of Documents, Government Printing Office, Washington, DC 20402.

**31. ASTM D 3955-86 ELECTRICAL INSULATING VARNISHES**

NOTE—As listed in Table 1 of this specification, the minimum flash point of all grades of insulating varnishes is IPO (Information Purposes Only), with a ± 10 percent of qualification value. These values are cited in ASTM Test Method D 115, which specifies D 56 for flash point.

**32. ASTM D 4010-83—WATERLESS HAND CLEANER**

**3. Classification**

3.1 The hand cleaner may be one of two types which each contains two classes:

3.1.1 *Type 1*—No Abrasive: Class A, regular and Class B, antimicrobial.

3.1.2 *Type 2*—With Abrasive: Class A, regular, and Class B, antimicrobial.

NOTE—As listed in Table 1 of this specification, the minimum flash point for all types of waterless hand cleaners is 38°C (100°F), in accordance with ASTM flash point methods D 3941 or D 3278.

**33. ASTM D 4011-81 (REAPPROVED 1986) LOTION SOAP**

NOTE—As listed in Table 1 of this specification, the minimum flash point for all types of lotion soap is 93°C (200°F), in accordance with ASTM flash point methods D 93 and D 3278.

**34. ASTM D 4022-81 COAL TAR ROOF CEMENT**

**5. Performance Requirements**

5.5 *Flash Point*—38°C (100°F) minimum.

**7. Test Methods**

7.6 *Flash Point*—Test Method 3143 (Test Method for Flash Point of Cutback Asphalt with Tag Open-Cup Apparatus) uses the same procedure as ASTM flash point method D 1310.

**35. ASTM D 4293-83 PHOSPHATE ESTER BASED FLUIDS FOR TURBINE LUBRICATION**

**3. Significance and Use**

3.2 Fire resistant fluids are more difficult to ignite and show little tendency to propagate a flame. The term “fire resistant fluid” does not mean that the fluid will not burn.

**5. Safety Precautions**

5.1 The fire tests are used to measure and describe the properties of the phosphate esters in response to heat and flame under controlled laboratory conditions and should not be considered or used for the description or appraisal of the fire hazard of the fluids under actual fire conditions.

5.2 Conducting tests for fire properties such as Test Method D 92 SAE AMS 3150C, could result in a serious fire or explosion. It is recommended that only experienced personnel run these tests.

5.3 Fumes generated by the above tests may be hazardous from the standpoint of both inhalation and skin irritation. Therefore, the Test Method D 92, should be conducted so that all fumes and vapors are contained in a draft-free shield in a hood. High pressure spray flammability tests should, if possible, be remotely controlled from an area outside of or isolated from the test room, or if necessary, by an operator(s) provided with protective clothing and breathing apparatus with safety glasses or face shields, or both, appropriate to the test environment.

NOTE—As listed in Table 1 of this specification, the fire properties of these fluids are as follows:

Requirements for Fire Resistant Turbine Lubricants— Specification D 4293				
Property	Test Method	Limits ISO Viscosity Grade		
		32	46	
Fire properties:				
Flash point, °C (°F), min	D 92	225 (437)	225 (437)	
Fire point °C (°F), min	D 92	325 (617)	325 (617)	
Hot manifold, °C (°F), min	SAE AMS 3150C	704 (1299)	704 (1299)	
Flammability, high temperature spray ignition (high pressure)	SAE AMS 3140C	Report	Report	

### 36. ASTM D 4304-84 MINERAL LUBRICATING OIL USED IN STEAM OR GAS TURBINES

#### 3. DEFINITIONS

3.1 *Type I Mineral Oils*—Oils for steam and gas turbine lubricating systems where the machinery does *not* require lubricants with enhanced load carrying capacity. Such oils normally contain rust and oxidation inhibitors plus other additives as needed to meet the specified performance characteristics. Type I oils usually are available in ISO-VG 32, 46, 68, and 100 (see Practice D 2422).

3.2 *Type II Mineral Oils*—Oils for steam and gas turbine lubricating systems where the machinery requires enhanced load carrying capacity. These oils are similar to Type I and are typically used in marine turbines. Such oils contain rust and oxidation inhibitors, plus mild extreme pressure (EP) additives and other additives as needed to meet the specified performance characteristics. Type II oils usually are available in ISO-VG 68, 100, and 150.

3.3 *Functional Properties*—These properties of the mineral lubricating oil which are required for the design, manufacture, and operation of the machinery. The equipment manufacturers and users may have some special requirements.

NOTE—As described in Appendix 1 of this specification, the significance of functional properties of turbine oils is as follows:

*ISO Viscosity Grade ASTM Test Method D 2422*—The International Standards Organization has established a viscosity classification system for industrial fluid lubricants. Such lubricants are classified by grades designated as ISO-VG based on their viscosities in centistokes at 40°C. The choice of viscosity grade for use in a particular turbine should comply with the turbine manufacturer's recommendations. Deviations must be agreed upon between the manufacturer and the purchaser.

*Flash Point ASTM Test Method D 92*—Flash point is the temperature at which the fluid contained in a test cup and heated at a constant rate will flash but not continue to burn when a flame is passed over the cup. It is indirectly a measure of both the volatility of the oil and the flammability of these volatiles. This is mainly of value as a quality control test.

NOTE—As listed in Tables 1 and 2 of this specification, the flash point for all turbine oil viscosity grades, except viscosity grade 150, is 180°C (356°F). The flash point for viscosity grade 150 is 210°C (410°F).



# 5

## ASTM Fire Property Standards Related to Flash Point

### INTRODUCTION

In addition to the flash point tests previously listed, there are a number of ASTM standards that, in some manner, are related to flash point testing of liquids. Several properties of liquids, namely flammable limits and autoignition temperatures, can be used to estimate the flash point of liquids.

Some liquid mixtures have no flash point while some flammable liquids show a closed cup flash point within the regulatory range of flammability but will not support combustion. ASTM standards for sustained burning are included in the flash point related ASTM standard test methods listed in this chapter.

Furthermore, the United Nations is at present investigating those test methods as well as fire test methods for regulatory purposes.

ever, other media may be substituted provided appropriate precautions are taken for their safe use.

### 3. Terminology

3.1 Definitions: (Refer to D 2883 for the figures mentioned below.)

3.1.1 *Hot-Flame Reaction*—a rapid, self-sustaining, luminous, sometimes audible reaction of the sample or its decomposition products with the atmosphere in the combustion chamber. A yellow or blue flame usually accompanies the reaction. Figures 1 through 3 illustrate the type of temperature records obtained for hot-flames.

3.1.2 *Cool-Flame Reaction*—a relatively slow, self-sustaining, barely luminous reaction of the sample or its decomposition products with the atmosphere in the combustion chamber. This type of flame is visible only in a darkened area. Figures 4 through 7 illustrate the type of temperature records obtained for cool-flames.

3.1.3 *Pre-Flame Reaction*—a slow, nonluminous reaction of the sample or its decomposition products with the atmosphere in the combustion chamber. Figures 8 and 9 illustrate the type of temperature records obtained for pre-flame reactions.

3.1.4 *Catalytic Reaction*—a fast, self-sustaining, energetic, sometimes luminous, sometimes audible reaction that occurs as a result of catalytic action on the surface of the thermocouple or other solid surface within the combustion chamber.

3.1.5 *Noncombustive Reaction*—a reaction other than combustion or thermal degradation undergone by certain materials upon exposure to elevated temperatures. Thermal polymerization is an example of the type of reaction that may occur when dealing with potentially reactive substances.

3.1.6 *Reaction Threshold Temperature*—the lowest temperature at which any reaction of the sample or its decomposition products may be detected by a thermocouple or other sensing devices.

3.1.7 *Reaction Delay Time*—the time, measured in seconds, that elapses between the introduction of the sample into the reaction chamber and the attainment of maximum response from one of the sensors used to follow the reaction. (Fig. 3)

3.1.8 *Incipient Reaction Temperature*—the temperature obtained by extrapolation of a plot of the reciprocal of the reaction delay time versus the initial reaction temperature

**TABLE 5-1—Quick Reference to ASTM Fire Property Standards Relating to Flash Point.**

Fire Property Standard	BOS Volume
D 2883-87	05.02
D 4206-89	06.03
D 4207-82	06.03
D 4359-84	06.01
E 659-78(1989)	05.03, 14.02
E 681-85	14.02
E 771-81	14.02
E 918-83(1988)	14.02
E 1232-91	14.02

### 1. ASTM D 2883-87 REACTION THRESHOLD TEMPERATURE OF LIQUID AND SOLID MATERIALS

#### 1. Scope

1.1 This test method covers determination of the pre-flame, cool-flame, and hot-flame reaction threshold temperatures and the incipient reaction temperature of liquids and solids. Data may be obtained at pressures from low vacuum to 0.8 MPa (115 psia) for temperatures within the range from room temperature to 650°C (1200°F). This test method may be applied to any substance that is a liquid or a solid at room temperature and atmospheric pressure and that, at room temperature, is compatible with glass and stainless steel. Air is the intended oxidizing medium; how-

to that value of the reciprocal which represents infinite delay ( $t - 1 = 0$ ) (Fig. 15).

NOTE 1—The detection of sample reactions and the distinctions between different reactions are based upon the records produced by the various sensing devices used in the apparatus. The temperature record is basic to the method and shall be regarded as the primary source of such data. The use of a pressure record and the records of other sensing devices to obtain additional data is optional.

#### 4. Summary of Test Method

4.1 A small measured amount of the sample contained in a glass ampoule is introduced into a stainless steel reaction chamber maintained at preselected temperature and pressure. The reactions of the sample subsequent to its introduction into the reaction chamber are followed by monitoring the temperature or the temperature and pressure (optional) of the reaction as a function of time.

4.2 At any selected system pressure, the minimum temperature (reaction threshold temperature) required to produce a given reaction is determined as a function of the size of the sample employed. The delay times for cool-flame and hot-flame reactions are also measured. A plot of the reciprocal of the reaction delay time versus the initial reaction chamber temperature for a cool-flame or hot-flame reaction may sometimes be used to determine the incipient reaction temperature by extrapolation to infinite delay time ( $t - 1 = 0$ ).

NOTE 2—The hot-flame reaction, cool-flame reaction, and reaction threshold temperature obtained by this method may approximate those temperatures obtained by ASTM Test Method E 659, for hot-flame autoignition, cool-flame autoignition, and reaction threshold temperature, respectively.

#### 5. Significance and Use

5.1 The reaction thresholds of a material are a measure of the tendency of the material or its decomposition products to undergo gas phase reactions of various types. Hot-flame and cool-flame thresholds relate directly to reactions which are involved in autoignition phenomena. Pre-flame, catalytic and thermal polymerization thresholds also relate to autoignition in that they represent reactions which can be under some conditions the precursors of ignition reactions.

## 2. ASTM D 4206-89 SUSTAINED BURNING OF LIQUID MIXTURES BY SETAFLASH APPARATUS (OPEN CUP)

### Introduction

This method may be used in conjunction with a flash point determination. If the flash point of a mixture of flammable and nonflammable liquids or liquids of widely different flash points is below the upper limit of a flammability classification (for example, 38°C (100°F) specified by the U.S. Department of Transportation), this test may be conducted

to determine the sustained burning characteristics of the mixture.

This method is a modification of the test for combustibility now incorporated as Schedule 2 of the "Highly Flammable Liquids and Liquefied Petroleum Gases Regulation, 1972" of the United Kingdom under The Factories Act, 1961, which is also issued as British Standard BS-3900, Part A-11, Small Scale Test for Combustibility. This sustained burning test was studied and proposed by the ASTM Coordinating Committee for Flash Point and Related Properties. The major purpose of this test is similar to that of the British test—to provide a method for determining the sustained burning characteristics by directly observing this property rather than by deducing them from the flash point.

#### 1. Scope

1.1 This test method describes a procedure for determining the sustained burning characteristics of mixtures of flammable and nonflammable liquids and also mixtures containing liquids with widely different flash points.

#### 3. Summary of Test Method

3.1 A block of aluminum alloy, or other nonrusting metal of suitable heat conductivity, with a concave depression (called the well) is heated to the required temperature of 49°C (120°F). A standard source of flame, capable of being swiveled over the center of the well and at a given distance from it, is attached to the metal block.

3.2 Two mL of the product under test are transferred to the well after the product has reached the stated temperature. The flame is passed over the well, held there for a specified time, and then removed. The time of sustained burning is then noted.

#### 4. Significance and Use

4.1 Mixtures of flammable liquids and nonflammable liquids, such as an alcohol and water mixture, are classified by the U.S. Government by the definition of flammable liquid based on a closed-cup flash point method. Thus, mixtures may be classed as flammable even though they do not sustain burning. This test method determines the ability of a liquid mixture to sustain burning and when used with a closed-cup flash point method indicates the flammability characteristics of the mixture.

## 3. ASTM D 4207-82 SUSTAINED BURNING OF LOW-VISCOSITY LIQUID MIXTURE BY THE WICK TEST

### Introduction

This method suggested by the Chemical Specialties Manufacturers Association was studied and proposed by the ASTM Coordinating Committee on Flash Point and Related Properties and Interaction with Government Agencies on These

Properties. The major purpose of this test is to provide a method for determining the sustained burning characteristic by directly observing this property rather than inferring it from the flash point.

### 1. Scope

1.1 This test method describes a procedure for determining sustained burning characteristics of mixtures, especially mixtures of flammable and nonflammable liquids with a viscosity of below 45 SUS at 38°C (100°F) or 9.5 cSt at 25°C (77°F).

1.2 This method can be used also to determine the sustained burning characteristics of mixtures containing liquids with widely different flash points.

### 3. Significance and Use

3.1 Mixtures of flammable liquids and nonflammable liquids such as alcohol and water may have closed cup flash points and may be classed as flammable even though they do not sustain burning. This test determines the ability of a liquid mixture to sustain burning.

## 4. ASTM D 4359-84 DETERMINING WHETHER A MATERIAL IS A LIQUID OR A SOLID

### Introduction

Although not a flash point standard, Test Method D 4359 can be used to determine whether a material should be regulated as a liquid. If judged to be a liquid, definitions for flammability or combustibility, will be based on flash point standards.

### 1. Scope

1.1 This test method covers the determination of whether a viscous material is a liquid or a solid for regulatory purposes.

### 3. Summary of Method

3.1 The material under test is held at 38°C (100°F) in a tightly closed can. The lid is removed and the can inverted. The flow of the material from the can is observed to determine whether it is a solid or a liquid.

### 4. Significance and Use

4.1 Compliance with regulations often requires the determination of whether a material is a liquid or a solid. A similar test is used by the U.S. Department of Transportation for this purpose.

## 5. ASTM E 659-78 (REAPPROVED 1989) TEST METHOD FOR AUTOIGNITION TEMPERATURE OF LIQUID CHEMICALS

### Introduction

This method is one of several methods developed by ASTM Committee E-27 for determining the hazards of chemicals. It is designed to be used in conjunction with other tests to characterize the hazard potential of the chemical under test.

### 1. Scope

1.1 This test method covers the determination of hot- and cool-flame autoignition temperatures of a liquid chemical in air at atmospheric pressure in a uniformly heated vessel.

NOTE 1—Within certain limitations, this method can also be used to determine the autoignition temperature of solid chemicals which readily melt and vaporize at temperatures below the test temperature.

### 2. Terminology

#### 2.1 Definitions:

2.1.1 *Ignition, n*—initiation of combustion.

2.1.1.1 Ignition, which is subjective, is defined for this method as the appearance of a flame accompanied by a sharp rise in the temperature of the gas mixture. The determination is made in total darkness because some flames, such as cool-flames, are observed with difficulty.

2.2 *Autoignition, n*—the ignition of a material commonly in air as the result of heat liberation due to an exothermic oxidation reaction in the absence of an external ignition source such as a spark or flame.

2.3 *Autoignition temperature, n*—the minimum temperature at which autoignition occurs under the specified conditions of test.

2.3.1 Autoignition temperature is also referred to as spontaneous ignition temperature, self-ignition temperature, autogenous ignition temperature, and by the acronyms AIT and SIT. As determined by this method, AIT is the lowest temperature at which the substance will produce hot-flame ignition in air at atmospheric pressure without the aid of an external energy source such as a spark or flame. It is the lowest temperature to which a combustible mixture must be raised, so that the rate of heat evolved by the exothermic oxidation reaction will over-balance the rate at which heat is lost to the surroundings and cause ignition.

2.4 *Cool-Flame, n*—a faint, pale blue luminescence or flame occurring below the autoignition temperature (AIT).

NOTE 3—Cool-flames, occur in rich vapor-air mixtures of most hydrocarbons and oxygenated hydrocarbons. They are the first part of the multistage ignition process.

2.5 *Ignition Delay Time, n*—the time lapse between application of heat to a material and its ignition. It is the time in seconds between insertion of the sample into the

flask and ignition. It is maximum at the minimum autoignition temperature and also referred to as ignition lag.

### 3. Summary of Test Method

3.1 A small, metered sample of the product to be tested is inserted into a uniformly heated 500-mL glass flask containing air at a predetermined temperature. The contents of the flask are observed in a dark room for 10 min following insertion of the sample, or until autoignition occurs. Autoignition is evidenced by the sudden appearance of a flame inside the flask and by a sharp rise in the temperature of the gas mixture. The lowest internal flask temperature (T) at which hot-flame ignition occurs for a series of prescribed sample volumes is taken to be the hot-flame autoignition temperature (AIT) of the chemical in air at atmospheric pressure. Ignition delay times (ignition time lags) are measured in order to determine the ignition delay–ignition temperature relationship.

3.2 The temperatures at which cool-flame ignitions are observed or evidenced by small sharp rises of the gas mixture temperature are also recorded along with the corresponding ignition delay times. The lowest flask temperature at which cool-flame ignition occurs is taken to be the cool-flame autoignition temperature (CFT). Similarly, observations are made of any nonluminous pre-flame reactions, as evidenced by a relatively gradual temperature rise which then falls off to the base temperature. The lowest flask temperature at which these reactions are observed is the reaction threshold temperature (RTT).

NOTE 2—The hot-flame autoignition, cool-flame autoignition, and reaction threshold temperatures obtained by this method approximate those temperatures obtained by ASTM Test Method D 2883, Test for Reaction Threshold Temperature of Liquid and Solid Materials, for hot-flame reaction, cool-flame reaction, and reaction threshold respectively.

### 4. Significance and Use

4.1 Autoignition, by its very nature, is dependent on the chemical and physical properties of the material and the method and apparatus employed for its determination. The autoignition temperature by a given method does not necessarily represent the minimum temperature at which a given material will self-ignite in air. The volume of the vessel used is particularly important since lower autoignition temperatures will be achieved in larger vessels. Vessel material can also be an important factor.

4.2 The temperatures determined by this method are those at which air oxidation leads to ignition. These temperatures can be expected to vary with the test pressure and oxygen concentration.

4.3 This method is not designed for evaluating materials which are capable of exothermic decomposition. For such materials, ignition is dependent upon the thermal and kinetic properties of the decomposition, the mass of the sample, and the heat transfer characteristics of the system.

4.4 This method can be employed for solid chemicals which melt and vaporize or which readily sublime at the

test temperature. No condensed phase, liquid or solid, should be present when ignition occurs.

4.5 This method is not designed to measure the autoignition temperature of materials which are solids or liquids at the test temperature (for example, wood, paper, cotton, plastics, and high-boiling point chemicals). Such materials will thermally degrade in the flask and the accumulated degradation products may ignite.

4.6 This method was developed primarily for liquid chemicals but has been employed to test readily vaporized solids. Responsibility for extension of this method to solids of unknown thermal stability, boiling point, or degradation characteristics rests with the operator.

## 6. ASTM E 681-85 CONCENTRATION LIMITS OF FLAMMABILITY OF CHEMICALS

### 1. Scope

1.1 This test method covers the determination of the lower and upper limits of flammability of chemicals having sufficient vapor pressure to form flammable mixtures in air at one atmosphere pressure at the test temperature. This method may be used to determine these limits in the presence of inert dilution gases. No oxidant stronger than air should be used.

NOTE 1—The lower flammable limit and upper flammable limit are also referred to as the lower explosive limit (LEL) and upper explosive limit (UEL) respectively.

1.2 This test method is limited to an initial pressure of 101 kPa (1 atm) or less with a practical lower pressure limit of approximately 13.3 kPa (100 mm Hg). The maximum practical operating temperature of this equipment is approximately 150°C (302°F).

1.3 This method is one of several being developed by Committee E-27 for determining the flammability of chemicals.

### 2. Summary of Method

2.1 A uniform mixture of a gas or vapor with air is ignited in a closed vessel and the upward and outward propagation of the flame away from the ignition source is noted by visual observation. The concentration of the flammable component is varied between trials until the composition which will just sustain propagation of the flame is determined.

### 3. Definitions

3.1 *Lower Limit of Flammability or Lower Flammable Limit (LFL)*—the minimum concentration of a combustible substance that is capable of propagating a flame through a homogeneous mixture of the combustible and a gaseous oxidizer under the specified conditions of test.

3.2 *Upper Limit of Flammability or Upper Flammable Limit (UFL)*—the maximum concentration of a combustible substance that is capable of propagating a flame through a

homogeneous mixture of the combustible and a gaseous oxidizer under the specified conditions of test.

3.3 *Propagation of Flame*—as used in this method, the upward and outward movement of the flame front from the ignition source to the vessel walls, which is determined by visual observation.

#### 4. Significance and Use

4.1 The lower and upper limits of flammability of gases and vapors define the range of flammable concentrations in air.

4.2 Limits of flammability may be used to determine guidelines for the safe handling of volatile chemicals. They are used particularly in assessing ventilation requirements for the handling of gases and vapors.

NOTE 2—The break point between nonflammability and flammability occurs over a narrow concentration range at the lower flammable limit but is less distinct at the upper limit.

#### 5. Interferences

5.1 This method is not applicable to certain readily oxidized chemicals. If significant oxidation takes place when the vapors are mixed with air, unreliable results are obtained. Flow systems designed to minimize hold-up time may be required for such materials.

5.2 Measured flammable limits are influenced by flame-quenching effects of the test vessel walls. The test vessel employed in this method is of sufficient size to eliminate the effects of flame quenching for most materials. However, there may be quenching effects, particularly on tests run at subambient pressures. For certain amines, halogenated materials, etc., which have large ignition-quenching distances, tests should be conducted in larger diameter vessels.

### 7. ASTM E 771-81 SPONTANEOUS HEATING TENDENCY OF MATERIALS

#### 1. Scope

1.1 This method covers a small-scale laboratory procedure to determine the self heating tendency of liquid and solid chemicals by exposure to elevated temperatures in air in a controlled semi-adiabatic system.

#### 2. Summary of Method

2.1 A small quantity of the test material held within a loosely packed inert material is heated in a thermostatically controlled chamber and the sample temperature is monitored to determine the temperature rise due to exothermic reaction. Bath temperature, sample quantity, and particle size of solids are varied to obtain the relative self-heating temperature of the material.

#### 3. Significance

3.1 This method is applicable to **solid** and liquid materials and provides a means of accelerating the tendency of

a material toward spontaneous heating which may eventually lead to a fire.

3.2 Tests at temperatures covering the range expected in manufacturing processes or material usage can be of considerable value in determining safe operating conditions.

3.3 Exothermic reaction under test conditions is a positive indication of spontaneous heating tendencies of a material. Negative test results indicate the absence of detectable spontaneous heating behavior under the experimental conditions imposed, but should not be regarded as conclusive for all conditions, particularly those which may be considered adiabatic.

3.4 The spontaneous heating behavior of a material is affected by such factors as available surface area, availability of oxygen to the test specimen, humidity, sample moisture content, packing density, the test temperature, and loss of exothermic heat to the surroundings.

#### 4. Definitions

4.1 *Spontaneous Heating or Self Heating, n*—an exothermic reaction of a material due to slow or incomplete reaction that results in a temperature rise above that of its surroundings.

4.2 *Spontaneous Heating Temperature or Self-Heating Temperature, n*—the lowest temperature at which spontaneous or self heating occurs under the specified test conditions. This temperature refers to a much earlier stage of reaction than that associated with the autoignition temperature of the material.

### 8. ASTM E 918-83 (REAPPROVED 1988) STANDARD PRACTICE FOR DETERMINING LIMITS OF FLAMMABILITY OF CHEMICALS AT ELEVATED TEMPERATURE AND PRESSURE

#### 1. Scope

1.1 This practice covers the determination of the lower and upper concentration limits of flammability of combustible vapor-oxidant mixtures at temperatures up to 200°C (392°F) and initial pressures up to as much as 1.38 MPa (200 psia). This practice is limited to mixtures which would have explosion pressures less than 13.79 MPa (2000 psia).

#### 3. Terminology

##### 3.1 Definitions:

3.1.1 *Lower Limit of Flammability or Lower Flammable Limit (LFL)*—The minimum concentration of a combustible substance that is capable of propagating a flame through a homogeneous mixture of the combustible and a gaseous oxidizer under the specified conditions of test.

3.1.2 *Upper Limit of Flammability or Upper Flammable Limit (UFL)*—The maximum concentration of a combustible substance that is capable of propagating a flame through a homogeneous mixture of the combustible and a gaseous oxidizer under the specified conditions of test.

### 3.2 Description of Terms:

3.2.1 *Propagation of Flames*—As used in this practice, a combustion reaction that produces at least a 7% rise of the initial absolute pressure

$$\frac{P_2}{P_1} \geq 1.07$$

NOTE 1—This 7% rise in pressure corresponds to 1 psia (0.007 MPa) of initial pressure.

## 4. Summary of Practice

4.1 A mixture of gaseous or vaporized fuel with a gaseous oxidizer is prepared in a steel or other appropriate metal vessel at a controlled temperature and pressure. Proportions of the components are determined by measurement of partial pressures during filling of the vessel. Ignition of the mixture is attempted with a fuse wire, and flammability is deduced from the pressure rise produced. Fuel concentration is varied between trials until the limits of flammability have been determined. Composition of the mixtures which fix the flammable limits are confirmed by appropriate analysis.

## 5. Significance and Use

5.1 Knowledge of flammable limits at elevated temperatures and pressures is needed for safe and economical operation of some chemical processes. This information may be needed in order to start up a reactor without passing through a flammable range, to operate the reactor safely and economically, or to store or ship the product safely.

5.2 Limits of flammability data obtained in relatively clean vessels must be carefully interpreted and may not always be applicable to industrial conditions. Surface effects due to carbon deposits and other materials can significantly affect limits of flammability, especially in the fuel-rich region.

## 6. Limitations

6.1 This practice is not applicable to mixtures which undergo spontaneous reaction before ignition is attempted.

6.2 Measure limits of flammability are influenced by flame-quenching effects of the test vessel walls. The vessel described in this practice is suitable for use with most mixtures at elevated temperatures and pressures. For certain emines, halogenated materials etc., which have large ignition-quenching distances, tests may need to be conducted in larger diameter vessels.

## 9. ASTM E 1232-91 TEMPERATURE LIMIT OF FLAMMABILITY OF CHEMICALS

### Introduction

The temperature limit of flammability test measures the minimum temperature at which liquid (or solid) chemicals evolve sufficient vapors to form a flammable mixture with air under equilibrium conditions. This temperature is applicable for assessing flammability in large process vessels and similar equipment.

## 1. Scope

1.1 This test method covers the determination of the minimum temperature at which vapors in equilibrium with a liquid (or solid) chemical will be sufficiently concentrated to form flammable mixtures in air at atmospheric pressure. This test method is written specifically for determination of the temperature limit of flammability of systems using air as the source of oxidant and diluent. It may also be used for other oxidant/diluent combinations, including air plus diluent mixtures; however, no oxidant/diluent combination stronger than air should be used. Also, no unstable chemical capable of explosive decomposition reactions should be tested (see 8.3).

1.2 This test method is designed and written to be run at local ambient pressure and is limited to a maximum initial pressure of 1 atm abs. It may also be used for reduced pressures with the practical lower pressure limit being approximately 13.3 kPa (100 mm Hg). The maximum practical operating temperature of this equipment is approximately 150°C (302°F) (Note A1.2).

## 3. Terminology

### 3.1 Definitions:

3.1.1 *flashpoint*—the lowest temperature, corrected to a pressure of 101.3 kPa (760 mm Hg, 1013 mbar), at which application of an ignition source causes the vapors of the specimen to ignite under specified conditions of test.

3.1.2 *lower limit of flammability or lower flammable limit, (LFL)*—the minimum concentration of a combustible substance that is capable of propagating a flame through a homogeneous mixture of the combustible and a gaseous oxidizer under the specified conditions of test.

3.1.3 *lower temperature limit of flammability, (LTL)*—the lowest temperature, corrected to a pressure of 101.3 kPa (760 mm Hg, 1013 mbar), at which application of an ignition source causes a homogeneous mixture of a gaseous oxidizer and vapors in equilibrium with a liquid (or solid) specimen to ignite and propagate a flame away from the ignition source under the specified conditions of test.

### 3.2 Description of Term Specific to This Standard:

3.2.1 *propagation of flame*—the upward and outward movement of the flame front from the ignition source to the vessel walls, that is determined by visual observation.

## 4. Summary of Test Method

4.1 A pool of liquid is stirred in a closed vessel in an air atmosphere. The vapor-air mixture above this liquid is exposed to an ignition source and the upward and outward propagation of flame away from the ignition source is noted by visual observation. Temperature in the test vessel is varied between trials until the minimum temperature at which flame will propagate away from the ignition source is determined.

## 5. Significance and Use

5.1 The lower temperature limit of flammability is the minimum temperature at which a liquid (or solid) chemical will evolve sufficient vapors to form a flammable mixture

with air under equilibrium conditions. Knowledge of this temperature is important in determining guidelines for the safe handling of chemicals, particularly in closed process and storage vessels.

NOTE 1.—As a result of physical factors inherent in flashpoint apparatus and procedures, closed-cup flashpoint temperatures are not necessarily the minimum temperature at which a chemical will evolve flammable vapors (see Appendixes X2 and X3, taken in part from Test Method E 502). The temperature limit of flammability test is designed to supplement limitations inherent in flashpoint tests. It yields a result closely approaching the minimum temperature of flammable vapor formation for equilibrium situations in the chemical processing industry such as in closed process and storage vessels.

NOTE 2—As a result of flame quenching effects existing when testing in standard closed-cup flashpoint apparatus, there are certain chemicals that exhibit no flashpoint but do evolve vapors that will propagate a flame in vessels of adequate size. The temperature limit of flammability test chamber is sufficiently large to overcome flame quenching effects in most cases of practical importance, thus, usually indicating the presence of vapor-phase flammability.

5.2 The vapor concentration present at the lower temperature limit of flammability equals the lower flammable limit concentration as measured by Test Method E 681 and

extrapolated back to the same temperature. (This permits estimation of lower temperature limits of flammability if vapor pressure and concentration limit of flammability data are available. A comparison of results of the tests, thus, affords a check on test reliability, the reliability of vapor pressure data, or both.)

## 6. Interferences

6.1 This test method is not applicable to materials that undergo chemical changes when mixed with air. Examples include, but are not limited to, oxidation and polymerization.

6.2 Measured temperature limits are influenced by flame quenching effects of the test vessel walls. The test vessel employed in this test method is of sufficient size to eliminate these effects for most materials. For certain amines, halogenated materials, etc., that have large ignition-quenching distances, tests should be conducted in vessels with larger diameters than the one listed in this test method. Quenching effects become increasingly significant as the test pressure decreases.

NOTE—The test method should be consulted for the test procedures and the hazards involved (Sections 8 and 10). The reader may also desire to consult the test method for the rationale of the temperature limit of flammability test and commentary on the flash point test.

# Auxiliary ASTM Standards Used to Define Flammable and Combustible Liquids in Government Regulations

Since flash point information is used mostly for regulatory purposes, other ASTM standards are listed. These are included in Regulatory Agency's definitions for flammable or combustible liquids in addition to the flash point classification values.

The ASTM standards in this chapter are used to determine such properties as follows:

1. *Boiling Point*—used in addition to flash point to define flammable liquid.
2. *Viscosity of Liquids*—used to determine which standards should be used for testing the flash points of liquids with various viscosities.
3. *Test for Solids*—used to determine whether a very viscous material should be considered a liquid or a solid. If a solid, the material is subject to regulations for a solid rather than those for a liquid.

**TABLE 6-1**—Quick Reference to ASTM Standards Used to Define Flammable/Combustible Liquids in Government Regulations.

ASTM Standard/BOS Volume	Other ASTM Methods Used
D 86-82/05.01, 06.03	D 216, D 1078
D 88-81(1987)/04.04, 10.03	D 117, D 445, D 2161, D 2170
D 323-89/05.01	D 1267
D 445-88/05.01, 10.03	D 2170, D 2171
D 2170-85/04.03	
D 2171-88/04.03	

## 1. ASTM D 86-82 TEST METHOD FOR DISTILLATION OF PETROLEUM PRODUCTS

### 1. Scope

1.1 This method covers the distillation of motor gasolines, aviation gasolines, aviation turbine fuels, special boiling point spirits, naphthas, white spirit, kerosines, gas oils, distillate fuel oils, and similar petroleum products.

NOTE 2—For the distillation of natural gasoline, see ASTM Test Method D 216, Distillation of Natural Gasoline (IP Designation: 191). For the distillation of volatile organic liquids

or relatively pure solvents, see ASTM Test Method D 1078, Distillation Range of Volatile Organic Liquids.

NOTE 3—For the distillation of aviation turbine fuels and other products of such wide boiling range that the low distillation thermometer is inadequate, this method may be applied by substituting the high-distillation thermometer and using special operating conditions.

## 3. Summary of Method

3.1 A 100-mL sample is distilled under prescribed conditions which are appropriate to its nature. Systematic observations of thermometer readings and volumes of condensate are made, and from these data, the results of the test are calculated and reported.

## 4. Significance

4.1 Distillation (volatility) characteristics of petroleum products are indicative of performance in their intended applications. Petroleum products specifications generally include distillation limits to assure products of suitable volatility performance.

4.2 The empirical results obtained by use of this distillation method have been found to correlate with automotive equipment performance factors and with other characteristics of petroleum products related to volatility.

## 5. Definitions

5.1 *Initial Boiling Point*—The thermometer reading that is observed at the instant that the first drop of condensate falls from the lower end of the condenser tube.

5.2 *End Point or Final Boiling Point*—The maximum thermometer reading obtained during the test. This usually occurs after the evaporation of all liquid from the bottom of the flask. The term "maximum temperature" is a frequently used synonym.

5.3 *Dry Point*—The thermometer reading that is observed at the instant the last drop of liquid evaporates from the lowest point in the flask. Any drops or film of liquid on the side of the flask or on the thermometer are disregarded.

NOTE 4—The end point (final boiling point), rather than the dry point, is intended for general use. The dry point may



be reported in connection with special purpose naphthas, such as used in the paint industry. Also, it should be substituted for the end point (final boiling point) whenever the sample is of such a nature that the precision of the end point (final boiling point) cannot consistently meet the requirements given in the **Precision** section of this method.

5.4 *Decomposition Point*—The thermometer reading that coincides with the first indications of thermal decomposition of the liquid in the flask.

NOTE 5—Characteristic indications of thermal decomposition are an evolution of fumes, and erratic thermometer readings which usually show a decided decrease after any attempt is made to adjust the heat.

5.5 *Percent Recovered*—The volume in millilitres of condensate observed in the receiving graduate.

5.6 *Percent Recovery*—The maximum percent recovered.

5.7 *Percent Total Recovery*—The combined percent recovery and residue in the flask.

5.8 *Percent Loss*—100 minus the percent total recovery.

5.9 *Percent Residue*—The percent total recovery minus the percent recovery, or the volume of residue in millilitres, if measured directly.

5.10 *Percent Evaporated*—The sum of the percent recovered and the percent loss.

## 2. ASTM D 88-81 (REAPPROVED 1987) SAYBOLT VISCOSITY

### 1. Scope

1.1 This method covers the empirical procedures for determining the Saybolt Universal or Saybolt Furol viscosities of petroleum products at specified temperatures between 21 and 99°C (70 and 210°F). A special procedure for waxy products is indicated.

NOTE 1—ASTM Test Methods D 445 and D 2170 are preferred for the determination of kinematic viscosity. They require smaller samples and less time, and provide greater accuracy. Kinematic viscosities may be converted to Saybolt viscosities by use of the tables in ASTM Test Method D 2161. It is recommended that viscosity indexes be calculated from kinematic rather than Saybolt viscosities.

### 3. Definition

3.1 *Saybolt Universal Viscosity*—The corrected efflux time in seconds of 60 mL of sample flowing through a calibrated Universal orifice under specified conditions. The viscosity value is reported in Saybolt Universal seconds, abbreviated SUS, at a specified temperature.

3.2 *Saybolt Furol Viscosity*—The corrected efflux time in seconds of 60 mL of sample flowing through a calibrated Furol orifice under specified conditions. The viscosity value is reported in Saybolt Furol seconds, abbreviated SFS, at a specified temperature.

3.3 *Furol*—On acronym of "Fuel and road oils."

## 4. Summary of Method

4.1 The efflux time in seconds of 60 mL of sample, flowing through a calibrated orifice, is measured under carefully controlled conditions. This time is corrected by an orifice factor and reported as the viscosity of the sample at that temperature.

## 5. Significance and Use

5.1 This method is useful in characterizing certain petroleum products, as one element in establishing uniformity of shipments and sources of supply.

5.2 See ASTM Guide D 117 for applicability to mineral oils used as electrical insulating oils.

## 3. ASTM D 323-89 VAPOR PRESSURE OF PETROLEUM PRODUCTS (REID METHOD)

### 1. Scope

1.1 This method covers a determination of vapor pressure (Note 1) of gasoline. It is also applied to volatile crude oil and other volatile petroleum products, except liquefied petroleum gases.

NOTE 1—Because the external atmospheric pressure is counteracted by the atmospheric pressure initially present in the air chamber, the "Reid vapor pressure" is an absolute pressure at 37.8°C (100°F) in pounds-force per square inch (or kilopascals) (kPa = kN/m<sup>2</sup>). The "Reid vapor pressure" differs from the true vapor pressure of the sample due to some small sample vaporization and the presence of water vapor and air in the confined space.

NOTE 2—For determination of the vapor pressure of liquefied petroleum gases refer to ASTM Test Method D 1267.

### 3. Summary of Test Method

3.1 The liquid chamber of the vapor pressure apparatus is filled with the chilled sample and connected to the air chamber at 37.8°C (100°F) in a bath. The apparatus is immersed in a bath at 37.8°C (100°F) until a constant pressure is observed. The reading, suitably corrected, is reported as the Reid vapor pressure.

## 4. ASTM D 445-88 KINEMATIC VISCOSITY OF TRANSPARENT AND OPAQUE LIQUIDS (AND THE CALCULATION OF DYNAMIC VISCOSITY)

### 1. Scope

1.1 This test method covers the determination of the kinematic viscosity of liquid petroleum products (Note 1), both transparent and opaque, by measuring the time for a volume of liquid to flow under gravity through a calibrated glass capillary viscometer. The dynamic viscosity can be obtained by multiplying the measured kinematic viscosity by the density of the liquid.

NOTE 1—For the measurement of the viscosity of bitumens, see also Test Method D 2170, and Test Method D 2171/IP 222.

1.2 This test method is intended for application to liquids for which the shear stress and shear rates are proportional.

### 3. Terminology

#### 3.1 Definitions:

3.1.1 *Kinematic Viscosity*—A measure of the resistive flow of a fluid under gravity, the pressure head being proportional to the density,  $p$ , of the fluid; for gravity flow under a given hydrostatic head, the pressure head of a liquid is proportional to its density,  $p$ . For any particular viscometer, the time of flow of a fixed volume of fluid is directly proportional to its kinematic viscosity,  $\nu = \eta/\rho$ , where  $\eta$  is the dynamic viscosity coefficient. The kinematic viscosity coefficient has the dimension  $L^2/T$ , where  $L$  is a length, and  $T$  is a time. The cgs unit of kinematic viscosity is one centimetre squared per second and is called one stokes (symbol St). The SI unit of kinematic viscosity is one metre squared per second and is equivalent to  $10^4$  St. Frequently, the centistokes (symbol cSt) is used ( $1 \text{ cSt} = 10^{-2} \text{ St} = 1 \text{ mm}^2/\text{s}$ ).

3.1.2 *Density*—The mass per unit volume of the fluid. The dimension of density is  $M/L^3$ , where  $M$  is a mass. The cgs unit of density ( $\rho$ ) is one gram per cubic centimetre, and the SI unit of density is one kilogram per cubic metre.

3.1.3 *Dynamic Viscosity (Coefficient of)*—The ratio between the applied shear stress and rate of shear. This coefficient,  $\eta$ , is thus a measure of the resistance to flow of the fluid; it is commonly called the viscosity of the liquid. The dimension of the coefficient of dynamic viscosity is  $M/LT = FT/L^2$  depending on whether the dimension of viscosity is based on the  $M-L-T$  system or the  $F-L-T$  system (where  $F$  represents a force). The cgs unit of dynamic viscosity is one gram per centimetre per second = one dyne-second per centimetre squared and is called one poise (symbol P). The SI unit of dynamic viscosity is one pascal-second; for convenience its submultiple of millipascal-second is frequently used ( $1 \text{ mPa} \cdot \text{s} = 1 \text{ cP}$ ). Frequently, the centipoise (symbol cP) is used ( $1 \cdot \text{cP} = 10^{-2} \text{ P}$ ).

NOTE 2—Dynamic viscosity also denotes a frequency-dependent quantity in which shear stress and shear rate have a sinusoidal time dependence; it is hoped that this dual use of the same term will not be confusing.

### 4. Summary of Test Method

4.1 The time is measured in seconds for a fixed volume of liquid to flow under gravity through the capillary of a calibrated viscometer under a reproducible driving head and at a closely controlled temperature. The kinematic viscosity is the product of the measured flow time and the calibration constant of the viscometer.

### 5. Significance and Use

5.1 Many petroleum products, as well as non-petroleum materials, are used as lubricants for bearings, gears, compressor cylinders, hydraulic equipment, etc. The proper

operation of the equipment depends upon the proper kinematic viscosity or viscosity (sometimes called dynamic viscosity) of the liquid. Thus, the accurate measurement of kinematic viscosity and viscosity is essential to many product specifications.

5.2 The kinematic viscosity of many petroleum fuels is important for their proper use, for example, flow of fuels through pipe lines, injection nozzles and orifices, and the determination of the temperature range for proper operation of the fuel in burners.

## 5. ASTM D 2170-85 KINEMATIC VISCOSITY OF ASPHALTS (BITUMENS)

### 1. Scope

1.1 This test method covers procedures for the determination of kinematic viscosity of liquid asphalts (bitumens), road oils and distillation residues of liquid asphalts (bitumens) all at 60°C (140°F) and of asphalt cements at 135°C (275°F) (NOTE 1) in the range from 6 to 100 000 cSt.

1.2 Results of this test method can be used to calculate viscosity when the density of the test material at the test temperature is known or can be determined.

NOTE 1—This test method is suitable for use at other temperatures and at lower kinematic viscosities, but the precision is based on determinations on liquid asphalts and road oils at 60°C (140°F) and on asphalt cements at 135°C (275°F) only in the viscosity range from 30 to 6000 cSt.

### 3. Summary of Method

3.1 The time is measured for a fixed volume of the liquid to flow through the capillary of a calibrated glass capillary viscometer under an accurately reproducible head and at a closely controlled temperature. The kinematic viscosity is then calculated by multiplying the efflux time in seconds by the viscometer calibration factor.

### 4. Significance and Use

The kinematic viscosity characterizes flow behavior. The method is used to determine the consistency of bitumen as one element in establishing the uniformity of shipments or sources of supply. The specifications are usually at temperatures of 60° and 135°C (140°F and 266°F).

### 5. Definitions

5.1 *Kinematic Viscosity*—The ratio of the viscosity to the density of a liquid. It is a measure of the resistance to flow of a liquid under gravity. The SI unit of kinematic viscosity is  $\text{m}^2/\text{s}$ ; for practical use, a submultiple ( $\text{mm}^2/\text{s}$ ) is more convenient. The cgs unit of kinematic viscosity is  $1 \text{ cm}^2/\text{s}$  and is called a stoke (symbol St). The centistokes ( $1 \text{ cSt} = 10^{-2} \text{ St}$ ) is  $1 \text{ mm}^2/\text{s}$  and is customarily used.

5.2 *Density*—The mass per unit volume of liquid. The cgs unit of density is  $1 \text{ g}/\text{cm}^3$  and the SI unit of density is  $1 \text{ kg}/\text{m}^3$ .

5.3 *Viscosity*—The ratio between the applied shear stress and rate of shear is called the coefficient of viscosity of the liquid. This coefficient is a measure of the resistance to flow of a liquid. It is commonly called the viscosity of the liquid. The cgs unit of viscosity is 1 g/cm·s (1 dyne·s/cm<sup>2</sup>) and is called a poise (P). The SI unit of viscosity is 1 Pa·s (1 N·s/m<sup>2</sup>) and is equivalent to 10 P.

5.4 *Newtonian Liquid*—a liquid in which the rate of shear is proportional to the shearing stress. The constant ratio of the shearing stress to the rate of shear is the viscosity of the liquid. If the ratio is not constant, the liquid is non-Newtonian.

## 6. ASTM D 2171-88 VISCOSITY OF ASPHALTS BY VACUUM CAPILLARY VISCOMETER

### 1. Scope

1.1 This test method covers procedures for the determination of viscosity of asphalt (bitumen) by vacuum capillary viscometers at 60°C (140°F). It is applicable to materials having viscosities in the range from 0.036 to over 200000 P.

NOTE 1—This method is suitable for use at other temperatures, but the precision is based on determinations on asphalt cements at 60°C (140°F).

### 3. Definitions

3.1 *Newtonian Liquid*—A liquid in which the rate of shear is proportional to the shearing stress. The constant ratio of the shearing stress to the rate of shear is the viscosity of the liquid. If the ratio is not constant, the liquid is non-Newtonian.

3.2 *Viscosity*—The ratio between the applied shear stress and rate of shear is called the coefficient of viscosity. This

coefficient is thus a measure of the resistance to flow of the liquid. It is commonly called the viscosity of the liquid. The cgs unit of viscosity is 1 g/cm·s (1 dyne·s/cm<sup>2</sup>) and is called a poise (P). The SI unit of viscosity is 1 Pa·s (1 N·s/m<sup>2</sup>) and is equivalent to 10 P.

## 4. Summary of Test Method

4.1 The time is measured for a fixed volume of the liquid to be drawn up through a capillary tube by means of vacuum, under closely controlled conditions of vacuum and temperature. The viscosity in poises is calculated by multiplying the flow time in seconds by the viscometer calibration factor.

NOTE 2—The rate of shear decreases as the liquid moves up the tube, or it can also be varied by the use of different vacuum or different size viscometer. Thus, this method is suitable for the measurement of viscosities of Newtonian (simple) and non-Newtonian (complex) liquids.

## 5. Significance and Use

5.1 The viscosity at 60°C (140°F) characterizes flow behavior and may be used for specification requirements for cutbacks and asphalt cements.

## 7. Non Related Fire Standards

There are other fire related ASTM standards dealing with the response of materials, products and assemblies to heat and flame. These standards involve such things as buildings, structures, furniture, and carpets. Among these standards are ASTM E 84 Test Method for Surface Burning Characteristics of Building Materials and ASTM E 119 Method for Fire Tests of Building Constructions and Materials. These standards are outside the scope of this compilation.

**Part II: Other U.S. Standards,  
Specifications, Codes, Regulations, and  
Tariffs (Federal, State, and Municipal)**



# 7

# U.S. Federal Standards and Specifications

## STANDARDS AND SPECIFICATIONS OF THE UNITED STATES GOVERNMENT

### Scope

The document text cited in this section are composed of standard test methods for sampling, inspecting, and testing of various products and commodities produced by U.S. federal agencies.

The test methods, when cited in a specification, form an integral part of that specification. Such a citation, although referenced to the basic number of a method, is intended to apply to the latest version of the method as revised and as amended by a subsequent "change notice" to the standard.

Some methods are identical to those published by ASTM. These methods are listed in the contents of this publication. The details of such test methods are, thus, omitted from the standards listed in this chapter.

### 1.1 NUMBERING SYSTEM

Test methods are identified by numerical designations, each consisting of a basic number, and, in some instances, a revision number (decimal). These numbers may be further identified by a "T" suffix.

a. Basic number. The basic number of method is its official designation, and should be used without revision number whenever the method is referenced. The number always refers to the same method of determination, the same accuracy, and the same end results, regardless of revision status.

b. Revision number. Revision numbers appear as decimal additions to the basic numbers. These are assigned to basic numbers when changes are made in the method to clarify it or to give additional details that will increase the reproducibility of the test results.

c. Suffix T. The suffix "T" is used to denote a tentative status of the test. This tentative status is applied to newly developed tests or revisions, and is retained until the new method (or revision) has been adopted as standard. (Tentative methods are for optional use by all Federal Agencies.)

### 1.2 PURCHASE OF SPECIFICATION AND STANDARDS

Federal and military specifications and standards may be obtained as outlined under General Provisions in the Index

of Specifications and Standards. Federal Government activities may obtain the Index from established distribution points within their agencies. All others may purchase the Index, with cumulative monthly supplements as issued from the Superintendent of Documents, U.S. Government Printing Office, Washington, DC 20402.

Among the Federal test method standards listing flash-point and other related methods are Federal Test Method Standard No. 101C, Packaging Materials. Federal Test Method Standard No. 141C Paint, Varnish, Lacquer, and Related Materials, Methods for Sampling and Testing and Federal Test Method Standard No. 791C, Lubricants, Liquid Fuels, and Related Products.

Table 7-1 lists identical ASTM methods to their respective Federal Test Methods. These ASTM Test Methods may be used in place of these Federal Test Methods.

## 2. UNITED STATES DEPARTMENT OF DEFENSE INDEX OF SPECIFICATIONS AND STANDARDS

The following ASTM standards have been adopted by the United States Department of Defense (DOD). The information shown was obtained from the Index of Specifications and Standards, available from the U.S. Government Printing Office, Washington, DC 20402.

Table 7-2 lists the government standard designations with their Federal Supply Classification (ESC). The heading PREP in the following tables indicates the military services responsible for standards and specification preparing activities, as follows:

**ME** refers to:

Commander  
U.S. Army Mobility Equipment  
Research and Development Command  
Attn: STRBE-DS  
Ft. Belvoir, VA 22060

**EA** refers to:

Commander  
U.S. Army Amendment and Research & Development  
Command  
Attn: DRSMC-TSC-S(A)  
Aberdeen Proving Ground, MD 21010

**90 FLASH POINT STANDARDS AND THEIR USE**

The heading CUST in the following tables refers to the military service designated as custodian of the standard or specification, as follows:

**AS** refers to:

Commander  
 Naval Air Systems Command  
 Attn: AIR  
 Washington, DC 20361

**SH** refers to:

Commander  
 Naval Sea System Command  
 DOD Standardization Program & Documents Branch  
 Attn: SEA55Z3  
 Washington, DC 20362

**YD** refers to:

Commander  
 Naval Facilities Engineering Command  
 (FAC04M2C)  
 200 Stovell St.  
 Alexandria, VA 22332

**11** refers to:

ASD/ENESS  
 Wright Patterson AFB, OH 45433

**68** refers to:

SA-ALC/SFRM  
 Kelly AFB, TX 78241

**69** refers to:

HQ, AFLC/DSTZT  
 Wright-Patterson AFB, OH 45433

**PS** refers to:

Product Engineering Service Office  
 Two Skyline Place, Suite 1400  
 5203 Leesburg Pike  
 Falls Church, VA 22041

**SM** refers to:

Director  
 DARCOM Packaging, Storage and Containerization  
 Center  
 Attn: SDSTO-TP-S  
 Tobhanna, PA 18466

**TABLE 7-1—Federal Flash Point Methods with their referenced ASTM Test Methods.**

Title	Federal Method No.	Referenced ASTM Methods
<b>FEDERAL TEST METHOD NO. 101C</b>		
Flash and Fire Points by Cleveland Open-cup	4012	D 92
Flash Point of Pigmented Materials (Pensky-Martens Closed Cup Tester)	4012	D 93
Rate of Burning and/or Extent and Time of Burning of Flexible Plastics in a Vertical Position	4012	D 568
Flash Points and Fire Points of Liquids by Tag Open-Cup Apparatus	4012	D1310
<b>FEDERAL TEST METHOD NO. 141C</b>		
Flash Point of Volatile Materials (Tag Closed Tester)	4291	D 56
Flash Point of Lacquer Solvents or Diluents of Low Flash Point (Tag Closed Cup)	4292	D 56
Flash Point of Pigmented Materials (Pensky-Martens Closed Cup Tester)	4293	D 93
Flash and Fire Points by (Cleveland Open Cup)	4294	D 92
<b>FEDERAL TEST METHOD NO. 141-C AUXILIARY METHOD FOR FLAMMABILITY REGULATION CLASSIFICATION</b>		
Viscosity (Saybolt Viscometer)	4285	D 88
<b>FEDERAL TEST METHOD NO. TM791C</b>		
Flash Point by Tag Closed Tester	1101.8	D 56
Flash Point by Penky-Martens Closed Tester	1102.11	D 93
Flash and Fire Points by Cleveland Open Cup	1103.7	D 92
<b>FEDERAL TEST METHOD NO. TM791C AUXILIARY METHODS FOR FLAMMABILITY REGULATION CLASSIFICATION</b>		
Saybolt Viscosity	304.8	D 88
Viscosity (Kinematic) of Transparent and Opaque Liquids	305.7	D 445
Distillation of Petroleum Products	1001.13	D 86
Vapor Pressure of Petroleum Products (Reid Method)	1201.7	D 323

Three of the U.S. military specifications shown in Tables 7-3 and 7-4 (i.e., MIL-T-5624N, MIL-T-83133C and MIL-T-38219B) and the commercial specifications listed in Tables 7-7 and 7-8 have been obtained from the Exxon International Company's Bulletin, "Jet Fuel Specifications," 1990 edition, which provides information on specifications for hydrocarbon fuels for turbine aircraft. This publication is available from Exxon Company International, Marketing/Distribution, 200 Park Ave., Florham Park, NJ 07932.

In 1976 W.A. Affens of Naval Research Laboratory issue NRL Report 7999, Shipboard Safety. A Meaningful Flash Point Requirement for Navy Fuels. In this report offers are listed for several U.S. Military Specifications for Ship Propulsion Fuels, which showed flash point and fire point specifications. Table 7-6 lists the specifications from this reprint.

**TABLE 7-2—U.S. Department of Defense Test Methods.**

Title	ASTM Document Number	FSC	PREP	CUST
Flash Point by Pensky-Martens Closed Tester	D 93-77	9150	ME	ME SH 11
Flash and Fire Points by Cleveland Open Cup	D 92-78	9150	ME	ME SH 11
Flash Point of Liquids by Tag Open Cup	D 1310	...	ME	EA YD 68
Flash Point by Tag Closed Tester	D 56-77	9150	ME	ME SH 11
Flash Point of Liquids by Setaflash Closed Tester	D 3278-78	6810	EA	EA YD 68

**TABLE 7-3—U.S. Military Specifications Operational Fuels.**

Agency	USAF	USAF
Specification Title	MIL-T-5624N Amend 1 Turbine Fuel Aviation February 10, 1989	MIL-T-83133C Amend 1 Turbine Fuel Aviation February 10, 1989
Latest Revision Date	February 10, 1989	February 10, 1989
Grade Designation	JP-4	JP-8
Fuel Type	Wide-Cut	Special Test Fuel
Flash Point °C (°F) min.	60 (140)	38 (100.4)
ASTM Flash Point Method	D 93	D 93
FSC	9130	9130
CUST	ME AS 11 PS	ME AS 11
PREP	11	11

**TABLE 7-4—U.S. Military Specification Special and Referee Test Fuels.**

Agency	USAF	USAF
Specification Title	MIL-T-38219B Turbine Fuel Low Volatility March 1, 1985	MIL-T-25524Ca Turbine Fuel Aviation Thermally Stable January 30, 1981
Latest Revision Date	March 1, 1985	January 30, 1981
Grade Designation	JP-7	Th Stable
Fuel Type	Low Volatility	Kerosene
Flash Point, °C (°F) min.	60 (140)	43 (109.4)
ASTM Flash Point Method	D 93, D 56, D 3828	D 93
FSC	9130	9130
PREP	11	11
CUST	11	11

**TABLE 7-5—U.S. Military Specifications Missile Fuels.**

Agency	USAF	US Navy
Specification Title	MIL-P-87107B Amend 1a Propellant High Density Synthetic Hydrocarbon Type April 23, 1981	MIL-P-82522Aa Propellant, Jet Engine Th Dimer October 8, 1971
Revision Date	April 23, 1981	October 8, 1971
Grade Designation	JP 9; JP-10	RJ-4
Fuel Type	Propellant	TH-Dimer(2)
Flash Point, °C (°F) Min.	16-27 (60.8-80.6) 52 (125.6)	60-79.4 (140-175)
ASTM Flash Point Method	D 93, D 3828	D 93, D 3828
FSC	9135	9130
PREP	11	AS
CUST	11	68

92 FLASH POINT STANDARDS AND THEIR USE

**TABLE 7-6—Shipboard Safety—A Meaningful Flash Point Requirement for Navy Fuels.**

Agency	US Navy	US Navy
Specification	MIL-F-359E	MIL-F-16884G
Title	Fuel Oil Burner	Fuel, Naval Distillate
Revision Date	September 1965	March 1973
Fuel Type	Navy Special Oil (Fuel oil)	Diesel Fuel Marine
Flash Point, min.°F (°C)	66 (150.8)	60 (140)
Flash Point, min.°F (°C)	93 (199.4)	...
ASTM Flash Point Method	D 93, D 92	D 93
FSC	9140	9140
PREP	SH	SH
CUST	ME SH 68	ME SH 68

**TABLE 7-7—Commercial Specifications.**

Agency	IATA	...
Specification	Guidance Material	Joint Fueling System Checklist
Latest Revision Date	November 1988	Issue 13, May 1989
Grade Designation	...	Jet A-1
Fuel type	Kerosene	Kerosene
Flash Point, °C (°F) min.	38 (100.4)	38 (100.4)
ASTM Flash Point Method	D 56, D 3828	D 56, D 3828
IP Flash Point Method	170, 303	170, 303

**TABLE 7-8—Commercial Specifications Engine Manufacturers Requirements.**

Agency	Detroit Diesel Allison	General Electric
Specification	EMH-64H	D50TF2-S9
Latest Revision Date	July 18, 1973	May 18, 1989
Grade Designation	...	Class A/C
Fuel type	Kerosene	Kerosene
Flash Point°C (°F) min.	40.6-65.6(105-150)(*)	37.8 (100)
ASTM Flash Point Method	D 56, D 3828	D 56, D 3828



## 8

# Flash Point Standards of U.S. Standards Organizations

**TABLE 8-1**—Quick Reference to Flash Point Standards of Other U.S. Standards Organizations.<sup>a</sup>

Standards Organizations	Standard Number
ANSI	Uses ASTM Flash Point Methods D 56, D 92, D 93, D 3828
ABYC	P-12
AACCH	58-82085
AOC	CC9A, CC9B, TNIA, TN2A
AASHTO	M-172, T-48, T-73, T-79
CSMA	AG-3
EOA	FP-1
FMS	7-42, 7-42N
ICBO	9-1, 9-2, 9-3, 9-4, 9-6, UBSC10-1
NFPA	30, 49, 70, 321, 325A, 325M, 491M, 704M <sup>b</sup>
UL	340 <sup>c</sup>

<sup>a</sup>Titles for these standards and the full addresses of these organizations are listed in the text to follow.

<sup>b</sup>NFPA's Standard 321 is reprinted in part in section 10 of this chapter.

<sup>c</sup>UL's Standard 340 is reprinted in part in section 11 of this chapter.

## 1. AMERICAN NATIONAL STANDARDS INSTITUTE (ANSI), 1430 BROADWAY, NEW YORK, NY 10018

The American National Standards Institute is the official U.S. representative in the International Standards Organization (ISO). ANSI standards are produced by America's voluntary standards system, which is a federation of standards writing organizations, commerce and industry, and public and consumer interests. ANSI is the coordinator for this voluntary standards system.

ANSI performs several major functions, including the following:

- Coordinating the voluntary development of national standards to ensure that they meet national needs, do not significantly overlap or conflict with each other, and are produced without unnecessary duplication of effort.
- Approving standards as American National Standards when it has verified that they meet consensus requirements.
- Managing and coordinating U.S. participation in the work of nongovernmental international standards bodies such as the International Organization for Standardization (ISO) and the International Electrotechnical Commission (IEC). ANSI is the U.S. member of both these organizations and the sole source in this country of their publications.

- Acting as a clearing house and information center for American National Standards and international standards.

While the Institute lists flash point methods and related standards in their catalog of ANSI standards, these methods have been produced by other standards organizations. These include some but not all of ASTM's flash point methods. The ANSI catalog also includes considerable numbers of National Fire Protection Association (NFPA) standards. The ANSI standards included in this volume are listed under the parent organization. However, other standards may be available from ANSI including all international standards.

The following ASTM flash point methods are listed in ANSI's Catalog: *D 56, Flash Point Closed Tester*; *D 92, Flash and Fire Points by Cleveland Open Cup*; *D 93, Flash Point by Pensky-Martens Closed Tester*; *D 3828, Flash Point by Seta-flash Closed Tester*.

Other organizations which produce flash point and related standards are listed below. The list of standards from all organizations except the National Fire Protection Association (NFPA) and Underwriters Laboratories (UL) was obtained from the National Institute of Standards and Technology Publication, NIST, Special Publication 329 (Supplement 1 and 2), an Index of U.S. Voluntary Engineering Standards, NIST, Gaithersburg, MD 20899. NFPA Standard 321 was obtained from the *NFPA Fire Protection Handbook*. UL Standard 340 was obtained from their publication, "Standard for Safety—Tests for Comparative Flammability of Liquids."

(Note: ASTM's flash point related methods and standards are covered in Chapters 1 through 6 of this manual.)

## 2. AMERICAN BOAT AND YACHT COUNCIL INC. (ABYC), 15 EAST 26TH ST., ROOM 1603, NEW YORK, NY 10010.

ABYC P-12, Recommended Practice and Standard Covering Portable Containers for Flammable Liquids.

## 3. AMERICAN ASSOCIATION OF CEREAL CHEMISTS AACCH, 3340 PILOT KNOB RD., ST. PAUL, MN 55121.

AACCH 58-82085. Smoke, Flash and Fire Points.

**4. AMERICAN OIL CHEMISTS' SOCIETY (AOC), 508 S. 6TH ST., CHAMPAIGN, IL 61820.**

AOC-CC9A. Smoke, Flash and Fire Points (commercial fats and oils).

AOC-CC9B. Flash Point Closed Cup Method (commercial fats and oils).

AOC-TN1A. Flash and Fire Points of Fatty Acids by Cleveland Open Cup Method.

AOC-TN2A. Flash and Fire Points of Fatty Quaternary Ammonium Chloride.

**5. AMERICAN ASSOCIATION OF STATE HIGHWAY TRANSPORTATION OFFICIALS (AASHTO), 341 NATIONAL PRESS BUILDING, WASHINGTON, DC 20004.**

AASHTO M 172. Standard Specifications for Pensky-Martens Closed Flash Tester.

AASHTO T-48. Method of Test for Flash and Fire Points by Cleveland Open Cup.

AASHTO T-73. Flash Point by Pensky-Martens Closed Tester.

AASHTO T-79. Flash Point with Taglibue Open Cup.

**6. CHEMICAL SPECIALTIES MANUFACTURERS ASSOCIATION (CSMA), 50 EAST 41ST ST., NEW YORK, NY 10017.**

CSMA AG-3. Method for Flammability of Aerosol Coatings.

**7. ESSENTIAL OIL ASSOCIATION OF U.S.A., INC. (EOA), 60 EAST 42ND ST., NEW YORK, NY 10017.**

EOA FP-1 Standard for Flash Points, Closed Cup, Aromatic Chemicals, and Isolates.

**8. FACTORY MUTUAL SYSTEM (FMS), 1151 BOSTON PROVIDENCE TURNPIKE, NORWOOD, MA 02062.**

The Factory Mutual System is involved in industrial fire and explosion prevention and in fuels and combustion testing and research. Among their flash point publications are:

FMS 7-42. Flash Point Index of Trade Name Liquids.

FMS 7-42N. Rec. for Flash Point Index of Trade Name Liquids (NFPA 325-A).

**9. INTERNATIONAL CONFERENCE OF BUILDING OFFICIALS (ICBO), 5360 SOUTH WORKMAN MILL ROAD, WHITTIER, CA 90601.**

ICBO 9-1. Flash Point by Tag Closed Tester (Uniform Building Code Standards).

ICBO 9-2. Flash Point by Pensky-Martens Closed Tester (Uniform Building Code Standards).

ICBO 9-3. Flash Point of Aviation Turbine Fuels by Setaflash Closed Tester (Uniform Building Code Standards).

ICBO 9-4. Flash Point of Liquids by Setaflash Closed Tester (Uniform Building Code Standards).

ICBO 9-6. Flash and Fire Points by Cleveland Open Cup (Uniform Building Code Standards).

ICBO UBCS10-1-Kerosine, Acetone, Alcohol Cleaning Fluids, Flammable Aerosols with a Flash Point Below 200°F.

**10. NATIONAL FIRE PREVENTION ASSOCIATION (NFPA), BATTERYMARCH PARK, QUINCY, MA 02269.**

The National Fire Protection Association is involved in many aspects of fire protection as it applies to life and property. It issues a large number of fire safety standards and codes for use by various industries, states, and municipalities. The following are concerned with flash point and related properties:

NFPA 30. Flammable and Combustible Liquid Code.

NFPA 49. Hazardous Chemicals Data.

NFPA 70. National Electric Code.

NFPA 321. Basic Classification of Flammable and Combustible Liquids (*see partial text below*).

NFPA 325A. Flash Point Index of Trade Name Liquids.

NFPA 325M. Fire Hazard Properties of Flammable Liquids, Gases and Volatile Solids.

NFPA 491M. Manual of Hazardous Chemical Reactions.

NFPA 704M. Recommended System for the Identification of the Fire Hazards of Materials.

NOTE—Article 500 of the National Electrical Code (NEC) classifies chemicals into a number of groups according to the safe use of electrical equipment in an atmosphere of these chemicals. In addition, the National Materials Advisory Board of the National Academy of Sciences (2101 Constitution Avenue, N.W., Washington, DC 20418) has published a compilation of chemicals classifying them by the NEC Groups and by organic and other chemical family groups. The title of the classification is "Matrix of Combustion-Relevant Properties and Classifications of Gases, Vapors and Selected Solids".

**Classification of Flammable and Combustible Liquids (from NFPA 321)**

NOTE—NFPA 321 © 1987 is reprinted with permission from the National Fire Protection Association. This reprinted material is not the complete and official position of NFPA

on the referenced subject which is represented only by the standard in its entirety.

**Liquid.** For the purpose of this classification, any material which has a fluidity greater than that of 300 penetration asphalt when tested in accordance with ASTM D 5, *Test for Penetration of Bituminous Materials*.

**Flammable Liquid.** A liquid having a flash point below 37.8°C (100°F) and having a vapor pressure not exceeding 40 psia (2068.6 mm Hg) at 37.8°C (100°F).

**Combustible Liquid.** A liquid having a flash point at or above 37.8°C (100°F).

**Flash Point.** The minimum temperature of a liquid at which sufficient vapor is given off to form an ignitable mixture with the air near the surface of the liquid or within the vessel used as determined by appropriate test procedure and apparatus specified below:

- *ASTM D 56*—For the flash point of a liquid having a viscosity below 5.5 at 40°C (104°F) or below 9.5 cSt at 25°C (77°F). Cut-back asphalts, those liquids which tend to form a surface film and materials which contain suspended solids are excluded from study by ASTM D 56, even if they otherwise meet the viscosity requirements.
- *ASTM D 93*—For the flash point of a liquid having a viscosity of 5.5 cSt or more at 40°C (104°F) or 9.5 cSt or more at 25°C (77°F) or a flash point of 93.4°C (200°F) or higher.
- *ASTM D 3278*—May be used as an alternate method for paints, enamels, lacquers, varnishes and related products and their components having flash points between 0°C (32°F) and 110°C (230°), and having a viscosity lower than 150 stokes at 25°C (77°F).
- *ASTM D 3828*—may be used for materials other than those for which D 3278 is specified.

**Vapor Pressure.** The pressure, measured in psia, exerted by a liquid, as determined by ASTM D 323, *Standard Test Method for Vapor Pressure of Petroleum Products (Reid Method)*.

**Boiling Point.** The boiling point of a liquid at a pressure of 14.7 psia (760 mm Hg). Where an accurate boiling point is unavailable for the material in question, or for mixtures which do not have a constant boiling point, for purposes of this classification the 10 percent point of a distillation performed in accordance with ASTM D 86, *Standard Test Method for Distillation of Petroleum Products*, may be used as the boiling point of the liquid.

## Classification of Liquids

*Class I*—Shall include those having flash points below 37.8°C (100°F) and may be subdivided as follows:

*Class IA*—Shall include those having flash points below 22.8°C (73°F) and having a boiling point below 37.8°C (100°F).

*Class IB*—Shall include those having flash points below 22.8°C (73°F) and having a boiling point at or above 37.8°C (100°F).

*Class IC*—Shall include those having flash points at or above 22.8°C (73°F) and below 37.8°C (100°F).

*Class II*—Shall include those having flash points at or above 37.8°C (100°F) and below 60°C (140°F).

*Class III*—Shall include those having flash points at or above 60°C (140°F) and may be subdivided as follows:

*Class IIIA*—Shall include those having flash points at or above 60°C (140°F) and below 93.4°C (200°F).

*Class IIIB*—Shall include those having flash points at or above 93.4°C (200°F)

## 11. UNDERWRITERS LABORATORIES (UL), 333 PFINGSTEN RD., NORTHBROOK, IL 60062.

The Underwriters Laboratories maintains and operates laboratories for the examination and testing of devices, systems and materials to determine their relation to life, fire, casualty hazards and crime prevention. They publish the results of their tests on products in "Product Directory" and the results of their research in safety problems in "Bulletin of Research." UL also published "Standards for Safety" volumes, one of which, UL 340, involving the flammability of liquids is excerpted below with permission from Underwriters Laboratories.

### Tests for Comparative Flammability of Liquids (UL 340-1979)

#### Scope

It is the purpose of this standard to provide a method, based on the results of specified flammability tests for the classification of fluids or liquids as nonflammable, or as flammable with the degree of fire hazard rated both in general terms and in a numerical scale, in comparison with well-known products whose hazards have been established by field experience.

The classifications derived by this method are evaluations of the inherent flammability of liquids and their vapors in storage, handling, and use under conditions of ordinary atmospheric temperatures and pressures or moderate deviations. Increases in fire hazard due to partial evaporation of components of certain liquid mixtures during handling and use are taken into account in assigning the fire hazard classification. The assigned classifications do not apply when the liquid is disseminated in the atmosphere in the form of finely divided spray, mist, or fog.

#### Classification System

This System measures and correlates the most important flammability characteristics of a particular liquid in terms of corresponding characteristics of a number of well-known liquids such as gasoline, ethyl alcohol, kerosine, and paraffin oil, the fire hazards of which have been established by field experience. The System provides both a general classification and a numerical rating of the fire hazards, based on a numerical scale of hazard ranging from 0 to 100-plus assigned to the reference liquids as indicated in the following:

General Classification	Numerical Classification
Diethyl ether class <sup>a</sup>	100-110
Gasoline class	90-100
Ethyl alcohol class	60-70
Kerosine class <sup>b</sup>	30-40
Paraffin oil class <sup>c</sup>	10-20

<sup>a</sup>Pure diethyl ether is rated 100.

<sup>b</sup>A standard kerosine of 37.8°C (100°F) flash point (closed cup) is rated 40.

<sup>c</sup>A paraffin oil of 226.6°C (440°F) flash point (closed cup) is rated 10.

# U.S. Code and Tariff Writing Organizations

## 1. ASSOCIATION OF AMERICAN RAILROADS, HAZARDOUS MATERIALS SYSTEMS, 50 F ST., N.W., WASHINGTON, DC 20001.

The Bureau of Explosives is now the Hazardous Materials Systems. This change indicates that a part of the Association of American Railroads is responsible for coordinating the railroad policy for the transportation of all hazardous materials, not just explosives. The Bureau assists the railroads in responding to incidents involving hazardous materials, maintains a field force of 18 inspectors to assist the railroads and chemical companies in complying with federal regulations, and publishes various documents concerning transportation of hazardous materials and emergency response. The Bureau has a laboratory that can assign the appropriate classifications to chemicals including explosives.

## 2. UNITED PARCEL SERVICE (UPS), 51 WEAVER ST., GREENWICH OFFICE PARK 5, GREENWICH, CT 06830.

UPS is a carrier, subject to DOT definitions of various hazardous materials. It has no classifications or designations that differ from those promulgated by DOT's OHMT. It publishes a *Guide for Shipping Hazardous Materials* which is referenced in their tariff. This guide provides for packaging requirements that sometimes exceed DOT requirements, and limits unit packages to sizes and weights compatible with their unique shipping environment.

## 3. BUILDING OFFICIALS AND CODE ADMINISTRATORS (BOCA), INTERNATIONAL, INC., 4051 W. FLOSSMOOR RD., COUNTRY CLUB HILLS, IL 60478.

BOCA publishes model building regulations for the protection of public health, safety, and welfare. The following excerpts of the "1990 National Fire Prevention Code," eighth edition, lists definitions of boiling point, combustible liquids, flammable liquids and solids and flash point. These are reprinted with permission from BOCA. All rights reserved.

### 3.1 Fire Prevention Code 1990

**Boiling point.** The temperature of boiling of a liquid at a pressure of 14.7 psig (760mm of mercury). Where an accu-

rate boiling point is unavailable for the material in question, or for mixtures which do not have a constant boiling point, and for the purposes of this classification, the 10 percent point of a distillation performed in accordance with ASTM D 86, shall be used as the boiling point of the liquid.

**Combustible liquids.** Any liquid having a flash point at or above 100°F (38°C) shall be known as Class II or III liquids. Combustible liquids shall be divided into the following classifications:

*Class II*—liquids having flash points at or above 100°F (38°C) and below 140°F (60°C).

*Class IIIA*—liquids having flash points at or above 140°F (60°C) and below 200°F (93°C).

*Class IIIB*—liquids having flash points at or above 200°F (93°C).

**Flammable.** Subject to easy ignition and rapid flaming combustion.

**Flammable liquids.** Any liquid having a flash point below 100°F (38°C), and having vapor pressure not exceeding 40 psia (276 kPa) at 100°F (38°C). Flammable liquids shall be known as Class I liquids and be divided into the following classifications:

*Class IA*—liquids having flash points below 73°F (23°C) and having a boiling point below 100°F (38°C).

*Class IB*—liquids having flash points below 73°F (23°C) and having a boiling point at or above 100°F (38°C).

*Class IC*—liquids having flash points at or above 73°F (23°C) and below 100°F (38°C).

(See "Combustible liquids" for Class II or III liquids.)

**Flammable solid.** A solid substance, other than one classified as an *explosive*, which is liable to cause fires through friction, through absorption of moisture, through spontaneous chemical changes, or as a result of retained heat from manufacturing or processing.

**Flash point.** The minimum temperature in degrees Fahrenheit at which a flammable liquid will give off sufficient vapors to form an ignitable mixture with air near the surface or in the container, but will not sustain combustion. The flash point of a liquid shall be determined by appropriate test procedures and apparatus as specified in ASTM D 56 and ASTM D 93 (see Chapter 2).

**Volatile-flammable.** Any liquid, gas substance, mixture or compound which readily emits flammable vapors at a temperature below 73°F (23°C) when tested in accordance with ASTM Method D 56.

# 10

## Local Government Regulations in the United States: States and Municipalities

### INTRODUCTION

The regulations and definitions of flammable and combustible liquids of all states and municipalities are too numerous to be included in this compilation volume. In the future, however, there may be sufficient uniformity in these regulations to publish specific information concerning their methods and specifications. Information concerning the local government regulations in other countries should be obtained from their respective organizations in these countries.

In the U.S., most of the governmental entities such as towns, cities, counties and states, use regulations or codes cited in the Fire Protection Association's Code 30, "Flammable and Combustible Liquids," or those specified in the Code of Federal Regulations (CFR).

Prior to the establishment of the U.S. Occupational Safety and Health Administration's (OSHA) use of closed-cup flash point methods, state and municipal regulatory bodies used the open-cup method to define flammable and combustible liquids. At present, a number of these governmental entities continues to specify open-cup methods in their regulations. The various governmental agencies involved in regulations for flammable and combustible liquids should be consulted for their specific regulations. While not all local regulations can be included in this compilation, excerpts from the codes of regulations of a few state and local governments are included. In addition, the ASTM flash point test methods cited herein are reprinted in full in Chapter 2 of this manual (i.e., D 56, D 93, D 1310, D 3278, and D 3828).

**1. STATE OF MICHIGAN, DEPARTMENT OF STATE POLICE, STATE FIRE SAFETY BOARD, FIRE MARSHALL DIVISION, HAZARDOUS MATERIALS UNIT, 7180 HARRIS DR., LANSING, MI 48913.**

The following is an excerpt from the *Rules for Storage of Flammable and Combustible Liquids*.

The State Fire Safety Board promulgated rules for the storage and transportation of flammable and combustible liquids which took effect on July 13, 1983, and rescinded the 1973 "Michigan Flammable Liquids Regulations."

The most noticeable change in these rules is that the rule document can no longer be used by itself but must be used in conjunction with the national standard which has been adopted by reference. The rules are amendments and additions to the National Fire Protection Association (NFPA) pamphlet No. 30, 1981, "Flammable and Combustible Liquids Code." Using the rules alone would be confusing and nonproductive. This action has been taken to maintain a high degree of consistency with recognized national standards. The definitions are found in NFPA Code 30.

**2. STATE OF NEW JERSEY, DEPARTMENT OF LABOR, DIVISION OF LABOR RELATIONS AND WORKPLACE STANDARDS, LABOR AND INDUSTRY BUILDING, TRENTON, NJ 08625.**

The following Table 10-1 lists the source of the definitions of flammable and combustible liquids and the state agencies responsible for New Jersey's regulations.

**3. STATE OF OHIO, OHIO DEPARTMENT OF COMMERCE, DIVISION OF STATE FIRE MARSHALL, 8895 EAST MAIN ST., REYNOLDSBURG, OHIO 43068.**

The Ohio fire code is based on the Boca Basic/National Fire Prevention Code/1990, containing approved amendments of the State of Ohio. (Ohio Fire Code—1301:7-7-02). Excerpts from this code on combustible liquids, flammable liquids, flammable solids, flash point and volatile-flammable are reprinted with permission from BOCA in Chapter 9 of this volume.

**4. COMMONWEALTH OF PENNSYLVANIA, FRY COMMUNICATIONS, INC., 800 W. CHURCH RD., MECHANICSBURG, PA 17055.**

The following excerpts are from the Commonwealth of Pennsylvania Codes.

TABLE 10-1—New Jersey State Agencies.

Jurisdiction	Rules	State Agency
Occupational safety and health in public sector	29 CFR Part 1910 and Part 1926 <sup>a</sup>	NJ Dept. of Labor
Intrastate transportation over highways	49 CFR Rules <sup>a</sup>	NJ Dept. of Transportation
Fire safety for protection of public	BOCA National Fire Prevention Code <sup>b</sup>	NJ Dept. of Community Affairs

<sup>a</sup>Code of Federal Regulations (CFR) excerpts for Code 29 and 49 are reprinted in Chapter 11 of this volume.

<sup>b</sup>Excerpts from BOCA's 1990 National Fire Protection Code are reprinted with permission in Chapter 9 of this volume.

#### 4.1 TITLE 37—LAW, PART 1 STATE POLICE, CHAPTER 11

##### Definitions

*Combustible liquid*—Any liquid having a flash point at or above 100°F (37.8°C) and below 200°F (93.4°C).

*Flammable liquid*—Any liquid having a flash point below 100°F (37.8°C) and having a vapor pressure not exceeding 40 psia (276 kPa) at 100°F (37.8°C); such liquids shall be known as Class I liquid.

*Flash point*—The flash point of the liquid shall mean the temperature at which the liquid gives off vapor sufficient to form an ignitable mixture with the air near the surface of the liquid or within the vessel used as determined by the following tests procedure and apparatus:

(i) The flash point of liquids having a flash point at or below 175°F (79°C), except for fuel oils and certain viscous materials, shall be determined in accordance with the standard method of test for flash point by the Tag closed tester.

(ii) The flash point of liquids having a flash point above 175°F (79°C), except for fuel oils, shall be determined in accordance with the standard method of test for flash point by the Cleveland open cup tester.

(iii) The flash point of fuel oil, and certain viscous materials having a flash point at or below 175°F (79°C), shall be determined in accordance with the standard method of test for flash point by the Pensky-Martens closed tester.

##### Classes of Flammable and Combustible Liquids

*Flammable liquids* shall be divided into the following classes:

- *Class I liquids*—shall include those having flash points below 100°F (37.8°C) and may be subdivided as follows:
- *Class IA*—shall include those having flash points below 73°F (22.8°C) and having a boiling point below 100°F (37.8°C).
- *Class IB*—shall include those having flash points below 73°F (22.8°C) and having a boiling point at or above 100°F (37.8°C).
- *Class IC*—shall include those having flash points at or above 73°F (22.8°C) and 100°F (37.8°C).

*Combustible liquids* shall be subdivided as follows:

- *Class II*—liquids shall include those having flash points at or above 100°F (37.8°C) and below 140°F (60°C).
- *Class III*—liquids shall include those having flash points at or above 140°F (60°C) and below 200°F (93.4°C).

The volatility of liquids is increased when heated to a temperature equal to or higher than their flash points. When so heated, Class II and Class III (combustible liquids) shall be subject to the applicable requirements for Class I and

Class II liquids. This subpart may also be applied to high flash point liquids, which otherwise would be outside of the scope when they are so heated.

#### 4.2 TITLE 67—TRANSPORTATION, HAZARDOUS MATERIAL, CHAPTER 403.2

##### Definitions

Any explosive, blasting agent, flammable liquid, combustible liquid, flammable solid, flammable and nonflammable compressed gas, corrosive material, poison, poison gas, irritant, oxidizer, organic peroxide, radioactive material, etiologic agent, or other regulated material defined in 49 CFR, Parts 100–177, as of January 1, 1983, whether a material, a substance or a waste product.

NOTE—CFR Code 49 is reprinted in part in Chapter 11 of this volume.

*Hazardous substance*—Any hazardous material meeting the definition of a hazardous substance in 49 CFR, Part 171.8, as of January 1, 1983.

*Hazardous waste*—Any hazardous material meeting the definition of a hazardous waste in 49 CFR, Part 171.8, as of January 1, 1983.

NOTE—Pennsylvania in 1983 adopted other sections of 49 CFR concerning general information, regulations, definitions, hazardous materials tables, hazardous materials regulations and general requirements for shipping and packaging. Excerpts of these 49 CFR sections are reprinted in Chapter 11 of this volume.

#### 4.3 TITLE 34—LABOR INDUSTRIAL BOARD, GENERAL BUILDING CLASSIFICATIONS

##### Classifications

All buildings enumerated in sections 4 through 8 of act of May 14, 1949 (No. 402), as amended, shall be classified as follows:

- *Class I*—the buildings in this class use Class I solvent which is any flammable petroleum solvent having a closed-cup tester flash point lower than 100°F (37.8°C).
- *Class II*—the buildings in this class use Class II solvent which is any flammable petroleum solvent having the following properties:

Flash point (closed-cup tester)	Lower than 59°C (138.2°F) but higher than 37.2°C (99°F)
Initial boiling Point	Lower than 181°C (357.8°F) but higher than 148.9°C (300°F)
Ignition temperature	Lower than 234°C (453.2°F) but higher than 204.4°C (400°F)
Lower limit of explosive range	Not less than 1.1 percent by volume of air
Spontaneous heating	The solvent shall not heat spontaneously.

• *Class III*—the buildings in this class use Class III solvent which is any flammable petroleum solvent having the following properties:

Flash point (closed cup tester)	Not lower than 59°C (138.2°F)
Initial boiling point	Not lower than 181°C (357.8°F)
Ignition temperature	Not lower than 234°C (453.2°F)
Lower limit of explosive range	Not less than 0.8 percent by volume in air at an initial temperature of 150°C (302°F)
Spontaneous heating	The solvent shall not heat spontaneously.

#### 4.4 TITLE 25—ENVIRONMENTAL RESOURCES, CHARACTERISTICS OF HAZARDOUS WASTE (75.261,G)

##### General

(i) A solid waste is a hazardous waste if it exhibits any of the characteristics identified in this subsection unless it is excluded as a hazardous waste in subsection (c).

(ii) A hazardous waste, identified by a characteristic in this subsection (h), is assigned the hazardous waste number of the respective characteristic as set forth in this subsection. This number shall be used in complying with the notification requirements and certain recordkeeping and reporting requirements under section 75.262–75.282.

(iii) For the purposes of this subsection, the Department will consider as representative a sample obtained using any of the applicable sampling methods, specified in subsection (h)(5)(i) or an equivalent method approved by the Department.

##### Characteristic of Ignitability

(i) A solid waste exhibits the characteristic of ignitability if a representative sample of the waste has any of the following properties:

- (A) It is a liquid with a flash point less than 60°C (140°F), as determined by a Pensky-Martens Closed Cup Tester, using the test method specified in ASTM D 93, or a Setaflash Closed Cup Tester, using the test method specified in ASTM D 3278, or as determined by an

equivalent test method approved by the Department under Section 75.260(c). An aqueous solution containing less than 24 percent alcohol by volume is excluded from this definition.

- (B) It is not a liquid and is capable, under standard temperature and pressure, of causing fire through friction, absorption of moisture, or spontaneous chemical changes, and, when ignited, burns so vigorously and persistently that it creates a hazard.
- (C) It is an ignitable compressed gas as defined in 49 C.F.R 173.300 (relating to definitions) and as determined by the test methods described in that regulation or equivalent test methods approved by the Department.
- (D) It is an oxidizer as defined in 49 CFR 173.151 (relating to definitions).

NOTE—CFR 49, paragraph 173 is reprinted in Chapter 11 of this volume.

(ii) A solid waste that exhibits the characteristic of ignitability, but is not listed as a hazardous waste in subsection (h), has the Hazardous Waste Number of D001.

##### Characteristic of Reactivity

(i) A solid waste exhibits the characteristic of reactivity if a representative sample of the waste has any of the following properties:

- (A) It is normally unstable and readily undergoes violent change without detonating.
- (B) It reacts violently with water.
- (C) It forms potentially explosive mixtures with water.
- (D) When mixed with water, it generates toxic gases, vapors, or fumes in a quantity sufficient to present a danger to human health or the environment.
- (E) It is a cyanide or sulfide bearing waste which, when exposed to pH conditions between 2.0 and 12.5, can generate toxic gases, vapors, or fumes in a quantity sufficient to present a danger to human health or the environment.
- (F) It is capable of detonation or explosive reaction if it is subjected to a strong initiating source or if heated under confinement.
- (G) It is readily capable of detonation, explosive decomposition, or reaction at standard temperature and pressure.

#### 5. CITY OF BALTIMORE, FIRE DEPARTMENT, FIRE PREVENTION BUREAU, OLD TOWNE STATION, 1100 HILLEN ST., BALTIMORE, MARYLAND 21202.

In 1988, the City of Baltimore adopted the definitions for flammable liquids and combustible liquids as published in the National Fire Prevention Code by Building Officials and Code Administrators, Inc. (BOCA). These definitions are reprinted in Chapter 9 of this publication with permission from BOCA.

## 6. CITY OF NEW YORK, BUREAU OF FIRE PREVENTION, FIRE DEPARTMENT, NEW YORK, NY.

### 6.1 Administrative Code, Title 27

As of May 1988, the New York City Fire Department's Bureau of Fire Prevention utilized Title 27 of the Administrative Code of the City of New York, when a certificate of approval or permit was sought to transport, sell, or store chemical specialty products in the City of New York. The following are excerpts from this code:

*Section 27-4002 Sub-division 22, Flammable Mixture*—Any liquid, or any mixture, substance, or compound which will emit a flammable vapor at a temperature below 100°F (38°C) when tested in a Tag open-cup tester.

*Section 27-4002 Sub-division 10, Combustible Mixture*—Any liquid or solid mixture or substance or compound which emits a flammable vapor at temperatures between 100°F (38°C) and 300°F (148°C), when tested in a Tag open-cup tester.

The standard test method used is ASTM D 1310, *Flash Point and Fire Point of Liquids by Tag Open-Cup Apparatus*.

*Subsection 10.b, Diesel Fuel Oil*—Any liquid used as a motor fuel which does not emit a flammable vapor below a temperature of 100°F (38°C) when tested in Tag open-cup tester.

*Section 23, Kerosene or Kerosene Oil*—Any liquid product of petroleum, commonly used for illuminating purposes, which does not emit a flammable vapor below a temperature of 100°F (38°C), when tested in a Tag open-cup tester.

The upper flash point was changed in 1988 for transportation purposes to 200°F (93.4°C) to be consistent with U.S. DOT.

### 6.2 REGULATIONS FOR THE STORAGE AND USE OF CHEMICALS, ACIDS, AND GASES IN COLLEGE, UNIVERSITY, HOSPITAL, RESEARCH AND COMMERCIAL LABORATORIES

The definitions of flammable and combustible liquids in Fire Prevention Directive 1-66 are as follows:

*Flammable liquid*—Any liquid mixture, substance, or compound which will emit a flammable vapor at a temperature below 100°F (38°C) when tested in a Tag closed-cup tester, using ASTM test method D 56.

*Combustible liquid*—A liquid mixture, substance, or compound having a flashpoint at or above 100°F (38°C) when tested in a Tag closed-cup tester using ASTM test method D 56.

## 7. CITY OF PHILADELPHIA, FIRE DEPARTMENT, 3RD & SPRING GARDEN STREETS, PHILADELPHIA, PA 19123.

### Definitions, Chemical, Chapter 5

In this Chapter, the following definitions apply:

### Hazardous Chemicals

Any material or mixture, having properties conforming to any of the following:

*Flammable Liquid or Solid*—A flammable or combustible liquid (as defined in Chapter 5-1601) or solid substance, other than explosive, which is likely to cause fires through friction, absorption of moisture, spontaneous chemical changes, or as a result of the heat retained in the solid from its manufacturing or processing.

*Oxidizing Material*—A substance such as a chlorate, a permanganate, a peroxide, or a nitrate that yields oxygen readily to stimulate the combustion of organic matter.

### Flammable and Combustible Liquids

NOTE—The City of Philadelphia adopted and incorporated into The Philadelphia Code, the 1976 National Fire Protection Association (NFPA) Standard No. 30, "Flammable and Combustion Liquids Code," together with all sectional references contained therein, and all other applicable references contained therein to other nationally recognized standards referenced in said standard, as governing all flammable and combustible liquids except those that are solid at 100°F (38°C) or above.

Unless otherwise provided in this chapter, the provisions as set forth in the 1976 National Fire Protection Association Standard No. 30, "Flammable and Combustible Liquids Code" shall apply. Classifications of occupancies dealing with descriptions of buildings or usages where Title 4, Title 5, or Title 7 of the Philadelphia Code of Ordinances apply shall supercede the definitions in the 1976 National Fire Protection Association Standard No. 30.

In this chapter the following definitions apply:

*Aerosol*—A material which is dispensed from its container as a mist, spray or foam by a propellant under pressure.

*Boiling Point*—The boiling point of a liquid at a pressure of 14.7 psia (760mm). Where an accurate boiling point is unavailable for the materials in question, or for mixtures which do not have a constant boiling point, for purposes of this Code, the 10 percent point of a distillation performed in accordance with ASTM D 86, *Standard Method of Test for Distillation of Petroleum Products*, may be used as the boiling point of the liquid.

*Flammable Aerosol*—An aerosol which is required to be labeled "Flammable" under the U.S. Federal Hazardous Substances Labeling Act. For the purpose of this Code (5-1604) such aerosols are considered Class IA liquids.

*Flash Point of a Liquid*—The minimum temperature at which a liquid gives off vapor in sufficient concentration to form an ignitable mixture with air near the surface of the liquid or within the vessel as specified by appropriate test procedure and apparatus as follows:

- The flash point of a liquid having a viscosity less than 45 SUS at 100°F (37.8°C) and a flash point below 200°F (93.4°C) shall be determined in accordance with ASTM D 56.
- The flash point of a liquid having a viscosity of 45 SUS or more at 100°F (37.8°C) or a flash point of 200°F (93.4°C) or higher shall be determined in accordance with ASTM D 93.



- Alternately, ASTM D 3828, *Standard Methods for Flash Point Setaflash Closed Tester*, may be used for testing aviation turbine fuels within the scope of this procedure.
- Alternately, ASTM D 3278, may be used for paints, enamels, lacquers, varnishes, and related products and their components having flash points between 32°F (0°C) and 230°F (110°C), and having a viscosity lower than 150 stokes at 77°F (25°C).

*Liquid*—Any material which has a fluidity greater than that of 300 penetration asphalt when tested in accordance with ASTM D 5, *Test for Penetration for Bituminous Materials*. When not otherwise identified, the term liquid shall mean both flammable and combustible liquids.

*Combustible Liquid*—A liquid having a flash point at or above 100°F (37.8°C). Combustible Liquids shall be subdivided as follows:

- *Class II Liquids*—Those liquids having flash points at or above 100°F (37.8°C) and below 140°F (60°C).
- *Class IIIA Liquids*—Those liquids having flash points at or above 140°F (60°C) and below 200°F (93.4°C).
- *Class IIIB Liquids*—Those liquids having flash points at or above 200°F (93.4°C).
- *Flammable Liquid*—A liquid having a flash point below 100°F (37.8°C) and having a vapor pressure not exceeding 40 psia (2068.6 mm Hg) at 100°F (37.8°C) and shall be known as a Class I liquid. Class I liquids shall be subdivided as follows:
- *Class IA Liquids*—Those liquids having flash points below 73°F (22.8°C) and having a boiling point below 100°F (37.8°C).
- *Class IB Liquids*—Those liquids having flash points below 73°F (22.8°C) and having a boiling point at or above 100°F (37.8°C).
- *Class IC Liquids*—Those liquids having flash points at or above 73°F (22.8°C) and below 100°F (37.8°C).

*Unstable (Reactive) Liquid*—A liquid which in the pure state or as commercially produced or transported will vigorously polymerize, decompose, condense, or will become self-reactive under conditions of shock, pressure, or temperature.

*Vapor pressure*—The pressure, measured in psia, exerted by a volatile liquid as determined by ASTM D 323, *Standard Method of Test for Vapor Pressure of Petroleum Products (Reid Method)*.

## 8. BALTIMORE COUNTY FIRE DEPARTMENT, TOWSON, MD 21204.

The Baltimore County (Maryland) Fire Department, in defining flammable and combustible liquids, utilized NFPA Standard 321 on Basic Classification of Flammable and

Combustible Liquids. Excerpts from this standard are reprinted in Chapter 8 of this volume with permission from NFPA.

For enforcement purposes it used the 1984 Building Officials and Code Administration Fire Prevention Code as adopted by the County Council Bill 17-85. Reference is also made to NFPA Standard 30, Code for Liquids, Flammable and Combustible.

## Summary

While local transportation codes or regulations may be in effect in the United States at this time, proposals made by the U.S. DOT may make present local transportation regulations obsolete.

Docket HM-200, Advance Notice No. 87, Hazardous Materials in Interstate Commerce, Advance Notice of Proposed Rule making (ANPRM) Research and Special Programs Administration (DOT); Federal Register/Vol.52, No. 124/June 29, 1987, Pages 24195–24197 invites comments on the need for, and possible consequences of DOT extending the application of its hazardous material regulations to all intrastate transportation of hazardous materials in commerce.

Information on the final disposition of this proposed rule making may be found when finalized in copies of Industrial Magazines such as the following:

American Paint & Coatings Journal  
2911 Washington Ave.  
St. Louis, MO 63103

Fuel Oil News  
38 Foley Ave.  
Edison, NJ 08820

Modern Paint and Coatings  
6255 Barfield Rd.  
Atlanta, GA 30328

Hazardous Materials Advisory Council  
Suite 907  
1012 Fourteenth St., NW  
Washington, DC 20005

Chemical & Engineering News  
American Chemical Society  
1155 16th St., NW  
Washington, DC 20036

Industrial Finishing  
Hitchcock Building  
Wheaton, IL 60188

Northeast Oil Reporter  
6525 Busch Blvd., #203  
Columbus, OH 43229

## 11

# U.S. Governmental Regulatory Agencies— Governmental Regulations

## INTRODUCTION

From the beginning of the development of flash point test methods the most important use for them was in government rules, regulations, or laws. Government agencies currently classify flammable liquids by use of these methods. In the United States, the following agencies specify flash point in regulations of flammable liquids under their jurisdiction: (1) the Department of Transportation (DOT) for regulations of transportation of these materials by sea, air, highway, and rail; (2) the Department of Labor's Occupational Safety and Health Administration (OSHA) for regulations of materials in the work place; (3) the Consumer Products Safety Commission (CPSC) for regulations of materials used in the home; and (4) the Environmental Protection Agency (EPA) for regulations of materials in the environment.

The regulations are published in the Code of Federal Regulations (CFR) which are available from Superintendent of Documents, Government Printing Office, Washington, DC 20402. In addition, CFRs can be obtained from the U.S. Government Printing Office book stores located in the federal buildings across the nation. For example, they may be obtained in Philadelphia at the United States Government Printing Office Book Store, Room 1214 Federal Building, 600 Arch St., Philadelphia, PA 19106, and in Pittsburgh at the United States Government Printing Office Book Store, Room 118 Federal Building, 100 Liberty Ave., Pittsburgh, PA 15222.

The Code of Federal Regulations is kept up-to-date by the individual issues of the Federal Register which are issued daily. The Office of Federal Register has published a pamphlet called "The Federal Register: What it is and How to Use It," which may be obtained from the Government Printing Office.

The following are excerpts from various CFRs. They deal mainly with definitions and classifications of flammable and combustible liquids, using the flash point and related properties to define and classify and prescribe packaging requirements for the liquids. When numbered paragraphs are mentioned without explanation and further information is desired, these paragraphs in the respective CFRs should be consulted.

The numbered subheads are specific to this flash point manual. The numbered paragraphs in parentheses are the original CFR paragraph designations. In addition, some metric equivalents have been added to the original CFR documents to maintain the format consistency of this flash

point manual. Table 11-1 provides a quick reference to the CFR flash point definitions and test procedures found in this chapter.

### 1. 49 CFR, PART A, U.S. DEPARTMENT OF TRANSPORTATION, RESEARCH AND SPECIAL PROGRAMS ADMINISTRATION (RSPA) (SUBCHAPTER C) HAZARDOUS MATERIALS REGULATIONS

Prior to the revisions of 49 CFR in 1990 and 1991 Hazardous Materials Regulations included such items as classification of hazardous materials by specific terms as flammable solids or explosives; packaging standards were based on detailed design specifications and the use of specific tests to define certain hazardous materials such as flammable liquids. Liquids were defined as flammable, which had a flash point of below 100°F (38°C), and combustible, which has a flash point at 100°F (38°C) and above to 200°F (18°C).

Docket HM-102 entitled *Definition of Flammable, Combustible, and Pyrophoric Liquids*, adopted the classification criteria for flammable, combustible, and pyrophoric materials, which indicated the above definitions for flammable and combustible liquids. A final rule was published (39 FR 2768) on January 24, 1974.

Summary: This notice amends the Hazardous Materials Regulations (HMR) to incorporate features found in the United Nations Committee of Experts' Recommendations on the Transport of Dangerous Goods, the technical instructions for the Safe Transport of Dangerous Goods by Air of the International Civil Aviation Organization (ICAO Technical Instructions), and the International Maritime Dangerous Goods (IMDG) Code of the International Maritime Organization (IMO). (See Chapter 15 of this manual for excerpts from these regulations). The intended effect of this action is to align the HMR with the U.N. Recommendations and the other international organizations in the areas of classification, packaging and hazard communication in the transport of hazardous materials.

These amended regulations are made because the existing HMRs are:

- 1) difficult to use because of their length and complexity;
- 2) relatively inflexible and outdated with regard to non-bulk packaging technology;
- 3) deficient in terms of safety with

TABLE 11-1—Quick reference to flash point basic definitions of U.S. Regulatory Agencies.

U.S. Agencies	CFR	CFR Section	MNL 9 Section	Apparatus	Flammable	Combustible
CPSC <sup>a</sup>	16	1500.3	6.1	Setaflash closed-cup	less than 37.8°C (100°F)	37.8°C (100°F) to and including 65°C (150°F)
	16	1500.3	6.1	tag open-cup	over -6.7 to 27°C (20 to 80°F)	over 27 to 65°C (80 to 150°F)
OSHA <sup>b</sup>	29	1910.106	5.1	tag closed-cup Pensky-Martens closed tester	less than 37.8°C (100°F)	37.8 to 93.4°C (100 to 200°F)
		1910.1200	5.2	tag closed-cup Pensky closed tester, Martens Setaflash closed tester	less than 37.8°C (100°F)	37.8 to 93.4°C (100 to 200°F)
RSPA <sup>c</sup>	49	173.120	1.1	tag closed Pensky-Martens closed tester, Setaflash closed tester	less than 37.8°C (100°F)	37.8 to 93.4°C (100 to 200°F)
Coast Guard	46	30.10	3.1	tag open-cup	at or below 27°C (80°F)	above 27°C (80°F)
EPA <sup>d</sup>	40	162.10	9.1	tag open-cup	at or below 27°C (80°F)	above 27 to 65°C (80°F)
	40	261.29	9.2	Pensky-Martens closed, Setaflash closed cup	less than 60°C (140°F)	...

<sup>a</sup>CPSC—U.S. Consumer Product Safety Commission.

<sup>b</sup>OSHA—U.S. Department of Labor, Occupational Safety and Health Administration.

<sup>c</sup>RSPA—U.S. Department of Transportation, Research and Special Programs Administration.

<sup>d</sup>EPA—U.S. Environmental Protection Agency.

regard to the classification and packaging of certain categories of hazardous materials; and 4) generally not in alignment with international regulations based on the U.N. Recommendations.

This action will: 1) simplify and reduce the volume of the HMR; 2) enhance safety through better classification and packaging; 3) promote flexibility and technological innovation in packaging; 4) reduce the need for exemptions from the HMR; and 5) facilitate international commerce.

The effective date of this final rule is October 1, 1991. However, compliance with the regulations as amended herein is authorized on or after January 1, 1991.

It is suggested the reader consult the December 21, 1990 and December 20, 1991 issues of the changes involved in these revisions of 49 CFR, which are excerpted and discussed in this chapter. The **Federal Register** referenced above also discusses the background for the 1990 and 1991 revision of the U.S. Department of Transportation regulations, which may be helpful in understanding the revisions of 49 CFR.

**NOTE**—Excerpts from two 49 CFR revisions are included below. The original and the 1990 49 CFR document are excerpted in Section 1, while revised versions, effective in 1991, are included and indicated by reference to 1991 in parentheses. Both are included herein because of the DOT's 5-year transition period from new to old documentation, which will allow use of both the old or new 49 CFR versions until 1996.

### 1.1 Matter Incorporated by Reference (171.1)

There is incorporated by reference in Parts 170-189 of this subchapter all matter referred to that is not specifically set

forth. These materials are hereby made a part of the regulations in Parts 170-189 of this subchapter. Unless the reference provides otherwise, matter subject to change is incorporated only as it is in effect on the date of issuance of the regulation referring to that matter.

All incorporated matter is available for inspection in the Dockets Branch, Room 8421 Nassif Building, 400 7th Street SW, Washington, DC 20590 and the office of the Federal Register, Room 8401, 1100 L St. N.W., Washington, DC.

Matter incorporated by reference is available for distribution as follows:

- ANSI: American National Standards Institute, Inc., 1430 Broadway, New York, NY 10018.
- ASTM: American Society for Testing and Materials, 1916 Race St., Philadelphia, PA 19103.
- ISO: International Organization for Standardization, Case Postale 56, CH-1211 Geneva 20, Switzerland.
- NFPA: National Fire Protection Association, 60 Battery-march St., Boston, MA 02110.

**NOTE:** Noncurrent ASTM standards are available from Engineering Societies Library, 554 E. 47th St., New York, NY 10017.

Availability of other matter incorporated by reference may be found in 49CFR, Subchapter C, Paragraph 171.7.

The full title and application of the matter incorporated by reference in this chapter are as follows:

**NOTE**—The ASTM flash point methods D 56, D 93, D 1310, and D 3278 are reprinted in Chapter 2 of this manual.

**ASTM**

- D 56—Method of Test for Flash Point by Tag Closed Tester.
- D 88—Method of Test for Saybolt Viscosity.
- D 93—Method of Test for Flash Point by Pensky-Martens Closed Tester.
- D 323—Test for Vapor Pressure of Petroleum Products (Reid Method).
- D 445—Test Method for Kinematic Viscosity of Transparent and Opaque Liquids (and the Calculation of Dynamic Viscosity).
- D 1200—Test Method for Viscosity of Paints, Varnishes, and Lacquers by Ford Viscosity Cup.
- D 1310—Method of Test for Flash Point of Volatile Flammable Materials by Tag Open-Cup Apparatus.
- D 2161—Method for Conversion of Kinematic Viscosity to Saybolt Universal Viscosity or to Saybolt Furoil Viscosity.
- D 3278—Methods of Test for Flash Point of Liquids by Setaflash Closed Tester.
- D 4359—Test Method for Determining Whether a Material is a Liquid or a Solid.
- E 681—Test Methods for Limits of Flammability of Chemicals
- ISO 2431—Paints and Varnishes—Determination of Flow Time by Use of Flow Cups

**1.2 Definitions and Abbreviations (171.8)**

*Bar*—Means 1 bar = 100 kPa (14.5 psi).

*Bulk packaging*—Means a packaging, other than a vessel or a barge, including a transport vehicle or freight container, in which hazardous materials are loaded with no intermediate form of containment and which has:

- (1) A maximum capacity greater than 450 L (119 gal) as a receptacle for a liquid;
- (2) A maximum net mass greater than 400 kg (882 lb) or a maximum capacity greater than 450 L (119 gal) as a receptacle for a solid; or
- (3) A water capacity greater than 454 kg (1000 pounds) as a receptacle for a gas.

*Class (Hazard class)*—Means the category of hazard assigned to a hazardous material under the definitional criteria of part 173 of this subchapter and the provisions of the § 172.101 Table. A material may meet the defining criteria for more than one hazard class but is assigned to only one hazard class.

*Competent Authority*—Means a national agency responsible under its national law for the control or regulation of a particular aspect of the transportation of hazardous materials (dangerous goods). The term “Appropriate Authority,” as used in the ICAO Technical Instructions, has the same meaning as “Competent Authority.” For purposes of this subchapter, the Associate Administrator for Hazardous Materials Safety is the Competent Authority for the United States.

*Division*—Means a subdivision of a hazard class.

*Domestic transportation*—Means transportation between places within the United States other than through a foreign country.

*Flash point*—Means the minimum temperature at which a substance gives off flammable vapors which, in contact with sparks or flame, will ignite.

*Hazardous material*—Means a substance of material which has been determined by the Secretary of Transportation to be capable of posing an unreasonable risk to health, safety, and property when transported in commerce, and which has been so designated.

*International transportation*—Means transportation:

- (1) Between any place in the United States and any place in a foreign country;
- (2) Between places in the United States through a foreign country; or
- (3) Between places in one or more foreign countries through the United States.

*Liquid*—Means material that has a vertical flow of over 2 in. (50 mm) within a 3 min period, or a material having one gram (1 g) or more liquid separation, when determined in accordance with the procedures specified in ASTM Test Method D 4359.

*Non-bulk packaging*—Means a packaging which has:

- (1) A maximum capacity of 450 L (119 gal) or less as a receptacle for a liquid;
- (2) A maximum net mass of 400 kg (882 lb) or less and a maximum capacity of 450 L (119 gal) or less as a receptacle for a solid; or
- (3) A water capacity of 454 kg (1000 lb) or less as a receptacle for a gas.

*ORM*—Means other regulated material.

*Outage or voltage*—Means the amount by which a packaging falls short of being full, usually expressed by volume.

*Packing group*—Means a grouping according to the degree of danger presented by hazardous materials. Packing Group I indicates great danger; Packing Group II, medium danger; Packing Group III, minor danger.

*Primary hazard*—Means the hazard class of a material as assigned in the § 172.101 Table.

*Solid*—Means a material which has a vertical flow of 2 in. (50 mm) or less within a 3 min period, or a separation of one gram (1 g) or less of liquid when determined in accordance with the procedures specified in ASTM Test Method D 4359.

*Spontaneously combustible material (solid)*—Means a solid substance (including sludges and pastes) which may undergo spontaneous heating or self-ignition under conditions normally incident to transportation or which may upon contact with the atmosphere undergo an increase in temperature and ignite.

*Subsidiary hazard*—Means a hazard of a material other than the primary hazard (see “primary hazard”).

*Viscous liquid*—Means a liquid material which has a measured viscosity in excess of 2500 centistokes at 25°C (77°F) when determined in accordance with the procedures specified in ASTM Test Method D 445 or ASTM Test Method D 1200.

*Volatility*—Refers to the relative rate of evaporation of materials to assume the vapor state.

*Water reactive material (solid)*—Means any solid substance (including sludges and pastes) which, by interaction with

water, is likely to become spontaneously flammable or to give off flammable or toxic gases in dangerous quantities.

**1.3 General Information, Regulations and Definitions (RSPA)**

**Units of Measure (171.10) (1991)**

*General*—To ensure compatibility with international transportation standards, most units of measure in this subchapter are expressed using the International System of Units (“SI” or metric). Where SI units appear, they are the regulatory standard. U.S. standard or customary units, which appear in parentheses following the SI units, are for information only and are not intended to be the regulatory standard.

Abbreviations for SI units of measure generally used throughout this subchapter are as shown in the paragraph below.

Customary units shown throughout this subchapter are generally not abbreviated.

*Conversion values*—Conversion values are provided in the following table and are based on values provided in ASTM E 380, *Standard for Metric Practice*, Section X-3.

If an exact conversion is needed, the following method should be used.

**1.4 Transitional Provisions for Implementing Requirements Based on the U.N. Recommendations (171.14)**

**Federal Register (December 21, 1990)**

*Purpose, Scope, and Exceptions*—A rule published in the **Federal Register** on December 21, 1990, effective October 1, 1991, resulted in a comprehensive revision of this subchapter based on the U.N. Recommendations. The purpose of the provisions of this section is to provide an orderly transition to the new requirements, so as to minimize any burdens associated with them. The transitional provisions below apply only to the new requirements in the December

21, 1990, rule and do not apply to the classification and hazard communication provisions of parts 172 and 173 of this subchapter for the following materials:

- (1) New explosives, as defined in paragraph 173.56 of this subchapter;
- (2) Infectious substances, as defined in paragraph 173.134 of this subchapter; and
- (3) Materials which are poisonous by inhalation, including poisonous gases, as defined in paragraph 173.115 and 173.132 of this subchapter.

*Transition Periods*—Notwithstanding the provisions of the December 21, 1990 rule and except as provided above, a hazardous material may be offered for transportation and transported, and packagings may be manufactured, maintained and used in accordance with the provisions of this subchapter which were in effect on September 30, 1991 until:

- 1) October 1, 1996, with regard to the maintenance and use of packagings under the provisions of part 173 of this subchapter, except for packagings for Division 2.3 materials and poisonous liquids subject to the “Poison-Inhalation Hazard” shipping paper description of 172.203(m) of this subchapter;
- 2) October 1, 1994, with regard to the manufacture and marking of packagings under the provisions of subpart B of part 173, subparts A, B, D, E, F, and G of part 178, and part 179 of this subchapter; and
- 3) October 1, 1993, with regard to all provisions of the December 21, 1990 rule, other than those addressed above.

Reference should be made to the List of CFR Sections Affected in the Finding Aids portion of this CFR volume to determine the sections affected by the December 21, 1990 rule.

*Retention of 1990 49 CFR*—Users of 49 CFR parts 100.180 and 46 CFR part 146 are urged to retain the October 1990 editions of the CFR containing the superseded rules. If the 1990 49 CFR or 46 CFR is not available from the Government Printing Office, a list of commercial sources may be obtained by writing the Office of Hazardous Materials Standards, Research and Special Programs Administration, U.S. Department of Transportation, 400 Seventh Street SW., Washington, DC 20590-0001.

Table of Conversion Factors for SI Units

Measurement	SI to U.S. Standard	U.S. Standard to SI
Length	1 cm = 0.3937008 in.	1 in. = 2.540000 cm
	1 m = 3.280840 ft	1 ft = 0.3048000 m
Thickness	1 mm = 0.03937008 in.	1 in. = 25.40000 mm
	1 kg = 2.204622 lb	1 lb = 0.4535924 kg
Mass (weight)	1 g = 0.03527397 oz	1 oz = 28.34952 g
	1 kPa = 0.1450377 psi	1 psi = 6.894757 kPa
Pressure	1 bar = 100 kPa = 14.5 psi	1 psi = 0.06 bar
	1 kPa = 7.5 mm Hg	
Volume (liquid)	1 L = 0.2641720 gal	1 gal = 3.785412 L
	1 mL = 0.03381402 oz	1 oz = 29.57353 mL
	1 m <sup>3</sup> = 35.31466 ft <sup>3</sup>	1 ft <sup>3</sup> = 0.02831685 m <sup>3</sup>
Density	1 kg/m <sup>3</sup> = 0.06242797 lb/ft <sup>3</sup>	1 lb/ft <sup>3</sup> = 16.01846 kg/m <sup>3</sup>

Abbreviations for units of measure are as follows:

Unit of measure and abbreviation:

(SI): Millimetre, mm; centimetre, cm; metre, m; gram, g; kilogram, kg; kiloPascal, kPa; litre, L; millilitre, mL; cubic metre, m<sup>3</sup>;

(U.S.): inch, in.; foot, ft; ounce, oz; pound, lb; pounds per square inch, psi; gallon, gal; cubic feet, ft<sup>3</sup>.

## 1.5 Transitional Provisions for Implementing Requirements on the U.N. Recommendations

### **Federal Register (December 20, 1991)**

*Purpose and scope.* A rule published in the **Federal Register** on December 21, 1990, effective October 1, 1991, resulted in a comprehensive revision of this subchapter based on the U.N. Recommendations. The purpose of the provisions of this section is to provide an orderly transition to the new requirements, so as to minimize any burdens associated with them. During a transition period as provided herein, persons may elect to comply with either the applicable old requirements of this subchapter in effect on September 30, 1991, or the new requirements of this subchapter appearing in the December 21, 1990 rule, and the rule published in the **Federal Register** on September 18, 1991, effective October 1, 1991.

*Transition dates.* The following transition dates apply only to the new requirements in the December 21, 1990 rule:

*October 1, 1991.* On October 1, 1991, the following requirements are effective:

For new explosives, the hazard classification procedures as set forth in subpart C of part 173 (for explosives) of this subchapter and, except for vehicle placarding, hazard communication requirements (i.e., shipping papers, emergency response information, package markings, and labeling) as set forth in part 172 of this subchapter.

The classification of materials poisonous by inhalation meeting the criteria of Division 2.3, which includes materials assigned Special Provision 13 in Column 7 of the § 172.101 Table; Division 6.1 or are otherwise identified as poisonous by inhalation through a special provision in Column 7 of the § 172.101 Table. For such materials, the words "Poison-Inhalation Hazard" or "Inhalation Hazard" as required by § 172.203(m) or by Special Provision 13, as appropriate, shall be entered on shipping papers in association with the basic description.

*October 1, 1992.* On October 1, 1992, the following requirements are effective:

Hazard communication requirements of part 172 of this subchapter (including placarding requirements of subpart F of part 172 of this subchapter) for all materials poisonous by inhalation, which includes materials meeting the criteria in §§ 173.115(c) and 173.133(a) of this subchapter or materials otherwise identified as poisonous by inhalation through a special provision (or assigned Special Provision 13) in Column 7 of the § 172.101 Table.

For infectious substances (etiologic agents), the hazard classification procedures as set forth in § 173.134 of this subchapter and hazard communication requirements (i.e., shipping papers, emergency response information, package markings, and labeling) as set forth in part 172 of this subchapter.

*October 1, 1993.* On October 1, 1993, the following requirements are effective:

Classification and hazard communication requirements in part 172 of this subchapter, other than subpart F (placarding), and part 173 of this subchapter, that were not previously in effect;

Packaging requirements for all materials meeting the criteria for poisonous by inhalation;

Modal segregation requirements in §§ 174.81 and 177.848 of this subchapter; and

All other requirements of the December 21, 1990, rule for which a lengthier transition period is not provided elsewhere in this section.

*October 1, 1994.* On October 1, 1994, the following are effective:

Placarding requirements in subpart F of part 172 of this subchapter that were not previously in effect; and

Package manufacturing and marking requirements under the provisions of subpart B of 173, and parts 178 and 179 of this subchapter. (DOT specification packagings removed from part 178 of this subchapter by the December 21, 1990, rule may no longer be manufactured.)

*October 1, 1996.* On October 1, 1996, requirements in parts 172 and 173 of this subchapter for maintenance and use of packagings that were not previously in effect are effective. (DOT specification packagings removed from part 178 of this subchapter by the December 21, 1990 final rule and packaging authorizations removed from part 173 of this subchapter by the December 21, 1990 final rule may no longer be used in place of new packaging requirements.)

*Other transitional provisions—*See **Federal Register** of December 20, 1991, 171.14 for additional provisions. These include (1) packages filled prior to October 1, 1991, (2) transitional placarding provisions, and (3) intermixing old and new requirements.

## 1.6 Purpose and Scope (173.1)

(d) In general, the Hazardous Materials Regulations (HMR) contained in this subchapter are based on the Recommendations of the United Nations Committee of Experts on the Transport of Dangerous Goods and are consistent with international regulations issued by the ICAO and IMO. However, the HMR are not consistent in all respects with the U.N. Recommendations, the ICAO Technical Instructions or the IMDG Code, and compliance with the HMR will not guarantee acceptance by regulatory bodies outside of the U.S.

## 1.7 Hazardous Materials Classes and Index to Hazard Class Definitions (173.2)

The hazard class of a hazardous material is indicated either by its class (or division) number, its class name, or by the letters "ORM-D." Table 3 lists class numbers, division numbers, class or division names and those sections of this subchapter which contain definitions for classifying hazardous materials, including forbidden materials.

## 1.8 Classification of a Material Having More Than One Hazard (173.2a)

Except as provided in paragraph (c) of this section, a material not specifically listed in the paragraph 172.101 Table that meets the definition of more than one hazard class or division as defined in this part, shall be classed according

TABLE 3—Class and division numbers.

Class Number	Division Number (if any)	Name of Class or Division	49 CFR Reference for Definitions
None		Forbidden materials	173.21
None		Forbidden explosives	173.53
1	1.1	Explosives (with a mass explosion hazard)	173.50
1	1.2	Explosives (with a projection hazard)	173.50
1	1.3	Explosives (with predominantly a fire hazard)	173.50
1	1.4	Explosives (with no significant blast hazard)	173.50
1	1.5	Very insensitive explosives; blasting agents	173.50
1	1.6	Extremely insensitive detonation	173.50
2	2.1	Flammable gas	173.115
2	2.2	Non-flammable compressed gas	173.115
2	2.3	Poisonous gas	173.115
3		Flammable and combustible liquids	173.120
4	4.1	Flammable solids	173.124
4	4.2	Spontaneously combustible materials	173.124
4	4.3	Dangerous when wet materials	173.124
5	5.1	Oxidizers	173.128
5	5.2	Organic peroxides	173.128
6	6.1	Poisonous materials	173.132
6	6.2	Infectious substances (Etiologic agent)	173.134
7	...	Radioactive materials	173.403
8	...	Corrosive materials	173.136
9	...	Miscellaneous hazardous materials	173.140
None	...	Other regulated material: ORM-D	173.144

to the highest applicable hazard class of the following hazard classes, which are listed in descending order of hazard:

- (1) Class 7 (radioactive materials, other than limited quantities).
- (2) Division 2.3 (poisonous gases).
- (3) Division 2.1 (flammable gases).
- (4) Division 2.2 (nonflammable gases).
- (5) Division 6.1 (poisonous liquids). Packing Group I, poisonous-by-inhalation only.
- (6) A material that meets the definition of a pyrophoric material in paragraph 173.124 of this subchapter (Division 4.2);
- (7) A material that meets the definition of a self-reactive material in paragraph 173.124 of this subchapter (Division 4.1).
- (8) Class 3 (flammable liquids), Class 8 (corrosive materials), Division 4.1 (flammable solids), Division 4.2 (spontaneously combustible materials), Division 4.3 (dangerous when wet materials), Division 5.1 (oxidizers) or Division 6.1 (poisonous liquids or solids other than Packing Group I, poisonous-by-inhalation). The hazard class and packaging group (1991) for a material meeting more than one of these hazards shall be determined using the precedence table in paragraph (b) of this section:
- (9) Combustible liquids; and
- (10) Class 9 (miscellaneous hazardous materials).

## 1.9 Precedence of Hazard Table (173.2b)

The following table ranks those materials that meet the definition of Classes 3 and 8 and Divisions 4.1, 4.2, 4.3, 5.1, and 6.1.

The following materials are not subject to the provisions of paragraph 173.2a above because of their unique properties (173.26):

(1) A Class 1 (explosive) material that meets any other hazard class or division as defined in this part shall be assigned a division in Class 1. Class 1 materials shall be classed and approved in accordance with paragraph 173.56 of this part;

(2) A Division 5.2 (organic peroxide) material that meets the definition of any other hazard class or division as defined in this part, shall be classed as Division 5.2;

(3) A Division 6.2 (infectious substance) material that meets the definition of any other hazard class or division as defined in this part shall be classed as Division 6.2;

(4) A material that meets the definition of a wetted explosive in paragraph 173.124 of this subchapter (Division 4.1). Wetted explosives are either specifically listed in the paragraph 172.101 Table or are approved by the Associate Administrator for Hazardous Materials Safety (see paragraph 173.124 of this subchapter); and

(5) A limited quantity of a Class 7 (radioactive) material that meets the definition for more than one hazard class or division shall be classed in accordance with paragraph 173.421.

## 1.10 Subpart D—Definitions, Classification, Packing Group Assignments and Exceptions for Hazardous Materials Other Than Class 1 and Class 7

### 1.10.1 Class 2, Division 2.1, 2.2, and 2.3—Definitions (173.115)

*Division 2.1 (Flammable Gas)*—For the purpose of this subchapter, a “flammable gas” (Division 2.1) means any material which is a gas at 20°C (68°F) or less and 101.3 kPa (14.7 psi) of pressure (a material which has a boiling point of 20°C (68°F) or less at 101.3 kPa (14.7 psi) which: 1) is ignitable at 101.3 kPa (14.7 psi) when in a mixture of 13 percent or less by volume with air or; 2) has a flammable range at 101.3 kPa (14.7 psi) with air of at least 12 percent regardless of the lower limit.

*Excerpt for Aerosols*—The limits specified in the above paragraph shall be determined at 101.3 kPa (14.7 psi) of pressure and a temperature of 20°C (68°F) in accordance with ASTM E 681, Test Method for Limits of Flammability of Chemicals.

*Flammable Range*—The term “flammable range” means the difference between the minimum and maximum volume percentages of the material in air that forms a flammable mixture.

*Division 2.2 (non-flammable, nonpoisonous compressed gas—including compressed gas, liquefied gas, pressurized cryogenic gas and compressed gas in solution)*. For the purpose of this

Precedence of Hazard Table (Hazard Class and Packing Group)

Hazard Class or Division	Packing Groups	4.2	4.3	5.1 I <sup>1</sup>	5.1 II <sup>1</sup>	5.1 III <sup>1</sup>	6.1 I(d)	6.1 I(o)	6.1 II	6.1 III	8 I(l)	8 I(s)	8 II(l)	8 II(s)	8 III(l)	8 III(s)
3	I						3	3	3	3	3	(3)	3	(3)	3	(3)
3	II						3	3	3	3	8	(3)	3	(3)	3	(3)
3	III						6.1	6.1	6.1	3	8	(3)	8	(3)	3	(3)
4.1	II <sup>2</sup>	4.2	4.3	5.1	4.1	4.1	6.1	6.1	4.1	4.1	(3)	4.1	(3)	4.1	(3)	4.1
4.1	III <sup>2</sup>	4.3	4.3	5.1	4.1	4.1	6.1	6.1	6.1	4.1	(3)	8	(3)	8	(3)	4.1
4.2	II		4.3	5.1	4.2	4.2	6.1	6.1	4.2	4.2	(3)	4.2	(3)	4.2	(3)	4.2
4.2	III		4.3	5.1	5.1	4.2	6.1	6.1	4.2	4.2	(3)	8	(3)	8	(3)	4.2
4.3	I			5.1	4.3	4.3	6.1	4.3	4.3	4.3	4.3	4.3	4.3	4.3	4.3	4.3
4.3	II			5.1	4.3	4.3	6.1	4.3	4.3	4.3	8	4.3	8	4.3	4.3	4.3
4.3	III			5.1	5.1	4.3	6.1	6.1	6.1	4.3	8	8	8	8	4.3	4.3
5.1	I <sup>1</sup>						5.1	5.1	5.1	5.1	5.1	5.1	5.1	5.1	5.1	5.1
5.1	II <sup>1</sup>						6.1	5.1	5.1	5.1	8	5.1	5.1	5.1	5.1	5.1
5.1	III <sup>1</sup>						6.1	6.1	6.1	5.1	8	8	8	8	5.1	5.1
6.1	I(d)										8	6.1	6.1	6.1	6.1	6.1
6.1	I(o)										8	6.1	6.1	6.1	6.1	6.1
6.1	II(d)										8	6.1	8	6.1	6.1	6.1
6.1	II(o)										8	6.1	8	6.1	6.1	6.1
6.1	III										8	8	8	8	8	8

(d) Dermal Toxicity  
 (o) Oral Toxicity  
 (l) Liquid  
 (s) Solid

<sup>1</sup>There are at present no established criteria for determining packing groups for liquids in Division 5.1. The degree of hazard for these materials should be assessed by analogy with listed substances, allocating the substances to Packing Group I (high hazard), Packing Group II (medium hazard) or Packing Group III (low hazard).

<sup>2</sup>Substances of Division 4.1 other than self-reactive substances.

<sup>3</sup>Denotes an impossible combination.

<sup>4</sup>For pesticides only, where a material has the hazards of Class 3, Packaging Group III, the primary hazard is Division 6.1, Packaging Group III.

subchapter, a “nonflammable, non-poisonous compressed gas” (Division 2.2) means any material (or mixture) which—

Exerts in the packaging an absolute pressure of 280 kPa (41 psia) at 20°C (68°F), and

Does not meet the definition of Division 2.1 or 2.3.

*Division 2.3 (Gas poisonous by inhalation).* For the purpose of this subchapter, a “gas poisonous by inhalation” (Division 2.3) means a material which is a gas at 20°C (68°F) or less and a pressure of 101.3 kPa (14.7 psi) (a material which has a boiling point at 20°C (68°F) or less at 101.3 k (14.7 psi) and which—

In the absence of adequate data on human toxicity, is presumed to be toxic to humans because when tested on laboratory animals it has an LC50 value of not more than 5000 mL/m<sup>3</sup>.

*Cryogenic liquid.* A “cryogenic liquid” means a refrigerated liquefied gas having a boiling point colder than -90°C (-130°F) at 101.3 kPa (14.7 psi) absolute. A material meeting this definition is subject to requirements of this subchapter without regard to whether it meets the definition of a non-flammable, non-poisonous compressed gas in paragraph.

**1.10.2 Class 3 Definitions (173.120)**

*Flammable Liquid*—For the purpose of this subchapter, a “flammable liquid” (Class 3) means any liquid having a flash point of not more than 60.5°C (141°F) (1991) with the following exceptions: 1) any liquid meeting one of the definitions specified in paragraph 173.115 above; 2) any mix-

ture having one or more components with a flash point greater than 60.5°C (141°F) or higher, that makes up at least 99 percent of the total volume of the mixture (1991).

For the purpose of this subchapter, a distilled spirit of 140 proof or lower is considered to have a flash point no lower than 23°C (73°F).

*Combustible Liquid*—For the purpose of this subchapter, a “combustible liquid” (Class 3) means any liquid that does not meet the definition of any other hazard class specified in this subchapter, except Class 9, and has a flash point above 60.5°C (141°F) and below 93°C (200°F) (1991).

Except when offered or intended for transportation by vessel or aircraft, a flammable liquid with a flash point at or above 38°C (100°F) that does not meet the definition of any other hazard class may be reclassified as a combustible liquid.

*Flash Point*—Flash point means the minimum temperature at which a liquid gives off vapor within a test vessel in sufficient concentration to form an ignitable mixture with air near the surface of the liquid. It shall be determined as follows.

For a homogeneous, single-phase, liquid having a viscosity less than 45 SUS at 38°C (100°F) that does not form a surface film while under test, one of the following ASTM test procedures shall be used:

- D 56—Test Method for Flash Point by Tag Closed Tester.
- D 3278—Test Methods for Flash Point of Liquids by Setafash-Closed-Cup Apparatus.

For a liquid other than one meeting all of the criteria of the above paragraph, one of the following ASTM test procedures shall be used.

- D 93—Test Methods for Flash Point by Pensky-Martens Closed Tester. For cutback asphalt, use Method B of ASTM



Methods D 93 or alternate tests authorized in this standard or D 3278—Test Methods for Flash Point of Liquids by Setaflash-Closed-Cup Apparatus

For a liquid that is a mixture of compounds that have different volatility and flash points, its flash point shall be determined as specified above on the material in the form in which it is to be shipped. If it is determined by this test that the flash point is higher than -7°C (20°F) a second test shall be made as follows. A portion of the mixture shall be placed in an open beaker (or similar container) of such dimensions that the height of the liquid can be adjusted so that the ratio of the volume of the liquid to the exposed surface is 6 to 1. The liquid shall be allowed to evaporate under ambient pressure and temperature 20 to 25°C (68 to 77°F) for a period of 4 hours or until 10 percent by volume has evaporated, whichever comes first. A flash point is then run on a portion of the liquid remaining in the evaporation container and the lower of the two flash points shall be the flash point of the material.

For flash point determinations by Setaflash closed tester, the glass syringe specified need not be used as the method of measurement of the test sample if a minimum quantity of 2 mL (0.1 oz) is assured in the test cup.

If experience or other data indicate that the hazard of a material is greater or less than indicated by the criteria specified in the paragraphs above on flammable or combustible liquids, the Associate Administrator for Hazardous Materials Safety may revise the classification or make the material subject or not subject to the requirements of Parts 170.189 of this subchapter.

**1.10.3 Class 3—Assignment of Packing Group (173.121)**

The packing group of a Class 3 material is as assigned in Column 5 of the 172.101 Table. When the 172.101 Table provides more than one packing group for a hazardous material, or indicates that the packing group is to be determined on the basis of the grouping criteria for Class 3, the packing group shall be determined by applying the criteria in the table below.

Packing Point Group	Flash Point (closed-cup)	Initial Boiling
I	...	<35°C (95°F)
II	<23°C (73°F)	>35°C (95°F)
III	>23°C, <60.5C (141°F)	>35°C (95°F)

Criteria for inclusion of viscous Class 3 materials in Packing Group III use type similar to above Class 3.

Viscous Class 3 materials in Packing Group II with a flash point of less than 23°C (73°F) may be grouped in Packing Group III provided that: 1) less than 3 percent of the clear solvent layer separates in the solvent separation test; 2) the mixture contains not more than 5 percent of substances in packing Group I or II of Division 6.1 or Class 8, or not more than 5 percent of substances in Packing Group I of Class 3 requiring a POISON or CORROSIVE subsidiary label; 3) the capacity of the packaging is not more than 30 L (7.9 gal); and 4) the viscosity and flash point are in accordance with the following table.

Flowtime in Seconds		Flash Point in °C (°F)
4 mm Cup	8 mm Cup	
Over 20	...	Over 17 (63)
Over 60	...	Over 10 (50)
Over 100	...	Over +5 (41) (1991)
Over 160	...	Over -1 (30)
Over 220	Over 17	Over -5 (23)
	Over 40	No lower limit

The methods by which the tests referred to above shall be performed are as follows.

*Viscosity Test*—The flow time in seconds is determined at 23°C (73°F) using the ISO Standard cup with a 4.0 mm (0.2 in.) jet (ISO 2431, *Paints and Varnishes—Determination of Flow Time by Use of Flow Cups*). Where the flowtime exceeds 200 s, a second test is carried out using the ISO standard cup but modified to take a jet of 8 mm (0.3 in.) diameter.

*Solvent Separation Test*—This test is carried out at 23°C (73°F) using a 100 mL (3 oz) measuring cylinder of the stoppered type of approximately 25 cm (9.8 in.) total height and a uniform internal diameter of approximately 30 mm (1.2 in.) over the calibrated section. The sample should be stirred to obtain a uniform consistency, and poured in up to the 100 mL (3 oz) mark. The stopper should be inserted and the cylinder left standing undisturbed for 24 hours. After 24 hours, the height of the upper separated layer should be measured and the percentage of this layer as compared with the total height of the sample calculated.

**1.10.4 Class 4, Divisions 4.1, 4.2, and 4.3—Definitions (173.124)**

*Division 4.1 (Flammable Solid)*—For the purpose of this subchapter, “flammable solid” (Division 4.1) means any of the following types of materials.

*Wetted Explosives That:* 1) when dry are Explosives of Class 1 other than those of compatibility group A, which are wetted with sufficient water, alcohol, or plasticizer to suppress explosive properties; and 2) are specifically authorized by name either in the 172.101 Table or have been assigned a shipping name and hazard class by the Associate Administrator for Hazardous Materials Safety under the provisions of an exemption issued under subchapter B of this chapter, or an approval issued under paragraph 173.56(i) of this part.

*Self-Reactive Materials*—Are materials that are liable to undergo, at normal or elevated temperatures, a strongly exothermal decomposition caused by excessively high transport temperatures or by contamination.

*Readily Combustible Solids*—Are materials that: 1) are solids which may cause a fire through friction, such as matches; 2) show a burning rate faster than 2.2 mm (0.087 inches) per second when tested in accordance with paragraph 2.c.(1) (1991) of Appendix E to this part; or 3) any metal powders that can be ignited and react over the whole length of a sample in 10 min or less, when tested in accordance with paragraph 2.c.(1) of Appendix E to this part (1991).

*Division 4.2 (Spontaneously Combustible Material)*—For the purpose of this subchapter, “spontaneously combustible material” (Division 4.2) means any of the following two types of materials:

*A Pyrophoric Material*—A pyrophoric material is a liquid or solid that, even in small quantities and without an external ignition source, can ignite within 5 min after coming in contact with air when tested according to paragraph 3.a.(1) or 3.a.(2) as appropriate, of Appendix E to this part (1991).

*A Self-Heating Material*—A self-heating material is a material that, when in contact with air and without an energy supply, is liable to self-heat. A material of this type which exhibits spontaneous ignition or if the temperature of the sample exceeds 200°C (392°F) during the 24 hour test period when tested in accordance with paragraph 3.b.(1) of Appendix E to this part is classed as a Division 4.2 material.

*Division 4.3 (Dangerous When Wet Materials)*—For the purposes of this subchapter, “dangerous when wet material” (Division 4.3) means a material that, by contact with water, is liable to become spontaneously flammable or to give off flammable or toxic gases at a rate greater than 1 L/kg of material per hour in accordance with paragraph 4 of Appendix E to this part.

#### *Class 4—Assignment of Packing Group (173.125)*

The packing group of a Class 4 material shall be as assigned in Column 5 of the 172.101 Table. When the 172.101 Table indicates that the packing group of a hazardous material is to be determined on the basis of test results following test methods given in Appendix E of this part, the packing group shall be determined by applying the appropriate criteria given in this section.

Packing group criteria for readily combustible materials of Division 4.1 is as follows.

*For materials other than metal powders*, a material is assigned to: 1) Packing Group II, if the burning rate is greater than 2.2 mm/s and the flame passes the wetted zone; or 2) Packing Group III, if the burning rate is greater than 2.2 mm/s and the wetted zone stops the flame.

*For metal powders*, a material is assigned to: 1) Packing Group II, if the zone of reaction spreads over the whole length of the sample in 5 min or less; or 2) Packing Group III, if the zone of reaction spreads over the whole length of the sample in more than 5 but not more than 10 min.

3) *Solids* which may cause a fire through friction are assigned to packing group by analogy with existing entries in the 172.101 Table.

Packing group criteria for Division 4.2 materials is as follows.

*Pyrophoric liquids and solids of Division 4.2* are assigned to Packing Group I.

*A self-heating material* is assigned to: Packing Group II, if the material gives a positive test result when tested with the 2.5-cm cube size sample; or 2) Packing Group III, if the material gives a positive test result when tested with the 10-cm cube size sample but a negative test result with the 2.5-cm cube size sample.

(d) A Division 4.3 dangerous when wet material is assigned to: 1) *Packing Group I*, if spontaneous ignition occurs, or demonstrates a tendency of spontaneous ignition, or the rate of evolution of flammable gases is equal or greater than 10 L/kg of material over any one minute; or 2) *Packing Group II*, if the rate of evolution of flammable gases is equal to or greater than 20 L/kg of material per hour, and which does not meet the criteria for Packing Group I; or 3) *Packing*

*Group III*, if the rate of evolution of flammable gases is greater than 1 L/kg of material per hour, and which does not meet the criteria for Packing Group I or II.

#### **1.10.5 Class 5, Division 5.1—Definition and Assignment of Packing Groups (173.127)**

For the purpose of this subchapter, “oxidizer” (Division 5.1) means a material that may, generally by yielding oxygen, cause or enhance the combustion of other materials.

A solid material is classed as a Division 5.1 material if, when tested in accordance with Appendix F to this part, in either concentration tested, the mean burning time of the test mixture, is equal to or less than that of the average of the three tests with ammonium persulfate mixture. A liquid is classed as a Division 5.1 material by analogy to existing entries in the § 172.101 Table.

(b) *Assignment of packing groups.* (1) The packing group of a Division 5.1 material shall be as assigned in Column 5 of the § 172.101 Table.

(2) When the § 172.101 Table indicates that the packing group of a solid oxidizer to be determined on the basis of the test results. See Appendix F to Part 173, Criteria for Classification, and Assignment of Packing Group.

#### *Class 5, Division 5.2—Definitions (173.128)*

*Division 5.2 (Organic Peroxide)*—For the purpose of this subchapter “organic peroxide” means any organic compound containing the oxygen (O) in the bivalent —O—O— structure and which may be considered a derivative of hydrogen peroxide where one or more of the hydrogen atoms have been replaced by organic radicals unless: 1) the material meets the definition of an explosive as prescribed in Subpart C of this part, in which case it must be classed as an explosive; 2) the material is forbidden to be offered for transportation according to paragraphs 172.101 or 173.21 of this subchapter; or 3) the Associate Administrator for Hazardous Materials Safety has determined that the material does not present a hazard which is associated with a Division 5.2 material or with additional items in 173.128.

#### *Exceptions for Class 3 (Flammable and Combustible Liquids) (173.150)*

*General*—Exceptions for hazardous materials shipments in the following paragraphs are permitted only if this section is referenced for the specific hazardous material in the 172.101 Table of this subchapter and the material does not meet the definition of another hazard class, except Class 9.

*Limited Quantities*—Limited quantities of flammable liquids (Class 3) are excerpted from labeling, unless offered for transportation or transported by aircraft, and the specification packaging requirements of this subchapter when packaged in combination packagings according to this paragraph. In addition, shipments of limited quantities are not subject to Subpart F (Placarding) of Part 172 of this subchapter. Each package must conform to the packaging requirements of Subpart B of this part and may not exceed 30 kg (66 lb) gross weight. The following combination packagings are authorized: 1) for flammable liquids in Packing Group I, inner packagings not over 0.5 L (0.1 gal) net capacity each, packed in strong outer packagings; 2) for flam-

mable liquids in Packing Group II, inner packagings not over 1.0 L (0.3 gal) net capacity each, packed in strong outer packaging; and 3) for flammable liquids in Packing Group III, inner packagings not over 5.0 L (1 gal) (1991) net capacity each, packed in strong outer packagings.

**Consumer Commodities**—A limited quantity which conforms to the provisions of the above paragraph and is a “consumer commodity” as defined in paragraph 171.8 of this subchapter, may be renamed “Consumer commodity” and reclassified as ORM-D material. In addition to the exceptions provided by the above paragraph, shipments of ORM-D materials are not subject to the shipping paper requirements of Subpart C of Part 172, unless the material meets the definition of a hazardous substance or hazardous waste or unless offered for transportation or transported by aircraft, and are eligible for the exceptions provided in paragraph 173.156.

**Alcoholic Beverages**—Alcoholic beverages (wine and distilled spirits as defined in 27 CFR 4.10 and 5.11) in packagings of 4 L or less are not subject to the requirements of this subchapter.

**Aqueous Solutions of Alcohol**—An aqueous solution containing 24 percent or less alcohol by volume and no other hazardous material: 1) may be reclassified as a combustible liquid; and 2) is not subject to the requirements of this subchapter if it contains no less than 50 percent water.

**Combustible Liquids**—A flammable liquid with a flash point at or above 38°C (100°F) that does not meet the definition of any other hazard class, except Class 9 may be reclassified as a combustible liquid. This provision does not apply to transportation by vessel or aircraft except where other means of transportation is available.

Unless otherwise stated for a specific material, the requirements in this subchapter do not apply to a material classed as a combustible liquid in a non-bulk packaging unless the combustible liquid is a hazardous substance or a hazardous waste.

A combustible liquid that is a hazardous substance or a hazardous waste, in a non-bulk packaging, and a combustible liquid in a bulk packaging is not subject to the requirements of this subchapter except those pertaining to: 1) shipping papers, waybills, switching orders, and hazardous waste manifests; 2) marking of packages; 3) display of identification numbers of bulk packages; 4) placarding requirements of Subpart F of Part 172 of this subchapter; 5) carriage aboard aircraft and vessels (for packaging requirements for transport by vessel see paragraph 176.340 of this subchapter); 6) reporting incidents as prescribed by paragraphs 171.15, 171.16 and 171.17 of this subchapter (1991); 7) packaging requirement of Subpart B of this part and in addition, non-bulk packagings must comply with requirements of 173.203 (1991); and 8) the requirements of paragraph 173.1, 173.21, 173.24, 173.24a, 173.24b, 174.1, 177.804, 177.817, and 177.834 of this subchapter.

A combustible liquid that is not a hazardous substance or a hazardous waste is not subject to the requirements of this subchapter if it is a mixture of one or more components that: 1) have a flash point at or above 93°C (200°F); 2) comprises at least 99 percent of the volume of the mixture, and 3) is not offered for transportation or transported as a liquid at a temperature at or above its flash point.

## 1.11 Appendix E to Part 173—Guidelines for the Classification and Packing Group Assignment of Class 4 Materials

### General

Tests and criteria for assignment to the three divisions of Class 4 are addressed below. The following principles should be applied to the classification of, and assignment of a packing group to, a new material or a new composition of existing material(s) not already covered by the entries in the 172.101 Hazardous Material Table.

### 1.11.1 Division 4.1 Material—Classification and Packing Group Assignment

A wetted explosive is listed as Division 4.1 in the 172.101 Hazardous Material Table after consideration of all appropriate data to ensure that its explosive properties are suppressed. Packing Group I is assigned to any wetted explosive.

A self-reactive material is listed in the 172.101 Hazardous Material Table after consideration of the particular properties of the material. The following considerations apply:

1. Any self-reactive material which, when packaged for transport, can detonate, is forbidden.
2. Any self-reactive material which in laboratory testing shows a high mechanical sensitivity and is liable to detonate or deflagrate rapidly is forbidden. (Deflagration is the subsonic transmission of a decomposition front through a material without the necessary participation of oxygen from the air.)
3. Any self-reactive material which in laboratory testing shows a high mechanical sensitivity is provisionally acceptable as a self-reactive material of Division 4.1, provided that this formulation does not detonate or deflagrate rapidly.
4. *Assignment of Packing Groups.* Packing Group II is assigned to self-reactive materials.

Readily combustible solids are classed in Division 4.1 in accordance with the following test methods and the procedure indicated in the flow-chart, figure E-1 of this appendix.

**Preliminary screening test.** The material in its commercial form, is formed into an unbroken strip or powder train about 250 mm long by 20 mm wide by 10 mm high on a cool, impervious, low-heat-conducting base plate.

A hot flame (minimum temperature 1000°C) from a gas burner (minimum diameter 5 mm) is applied to one end of the powder train until the powder ignites or for a maximum of 2 minutes (5 minutes for powders of metals or metal-alloys). Note whether combustion propagates along 200 mm of the train within the 2 minute test period (or 20 minutes for metal powders).

If the material does not ignite and propagate combustion either by burning with flame or smoldering along 200 mm of the powder train within the 2 minute (or 20 minute) test period, then the material may not be classified as a flammable solid and no further testing is required.

If the material propagates burning of a 200 mm length of the powder train in less than 2 minutes, or less than 20 minutes for metal powders, the full test program below must be carried out.

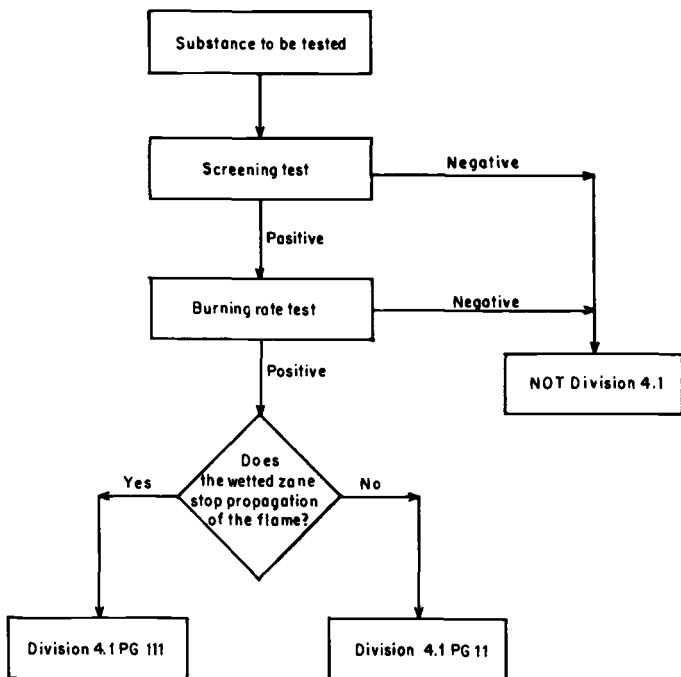
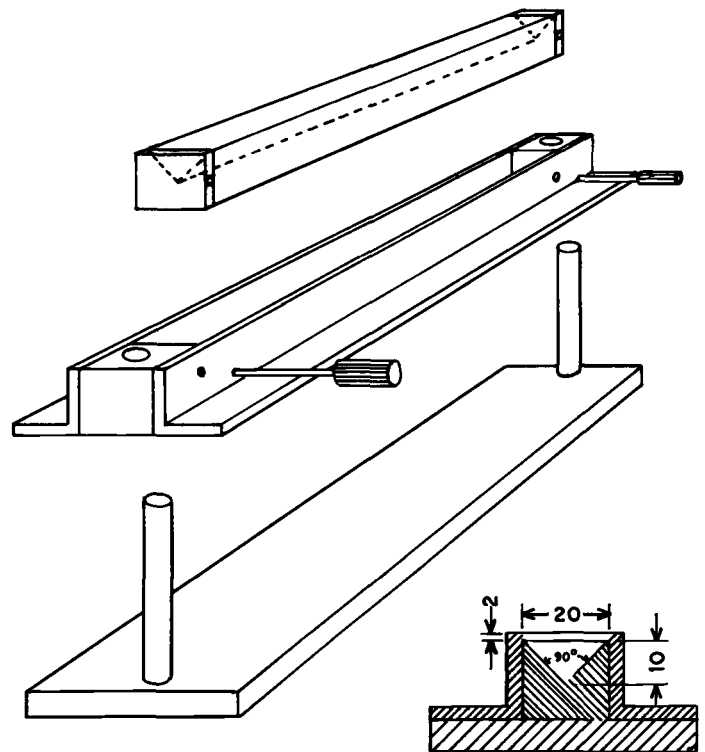

FIG. 1—Flow chart for assigning readily combustible solids (except metal powder) to Division 4.1.

**Burning rate test.** The powdered or granular material, in its commercial form, is loosely filled into a mold 250 mm long with a triangular cross-section of inner height 10 mm and width 20 mm. (See Figure E-2 of this appendix.) On both sides of the mold, in the longitudinal direction, two metal sheets are mounted as lateral limitations which extend 2 mm beyond the upper edge of the triangular cross-section (Figure E-2 of this appendix). The mold is then dropped three times from a height of 2 cm onto a solid surface. The lateral limitations are then removed and the impervious, non-combustible, low heat conducting plate is placed on top of the mold, the apparatus inverted and the mold removed. Pasty materials are spread on a non-combustible surface in the form of a rope 250 mm in length with a cross-section of about 1 cm<sup>2</sup>. Any suitable ignition source, such as a small flame or a hot wire of minimum temperature 1000°C, is used to ignite the pile at one end. In the case of a moisture-sensitive material, the test must be carried out as quickly as possible, after its removal from the container.

Arrange the pile across the draft in a fume-chamber. The air speed must be sufficient to prevent fumes escaping into the laboratory and should not be varied during the test. A draft screen may be erected around the apparatus.

Add 1 mL of a wetting solution to the pile 30–40 mm beyond the 100 mm timing zone. The addition of wetting agents may be necessary because, with many materials, water rolls off the sides of the pile. Wetting agents used must be free from combustible diluents and the total active matter in the wetting solution may not exceed 1 percent. This liquid may be added to a hollow up to 3 mm deep and 5 mm in diameter in the top of the pile. Apply the wetting solution to the ridge drop by drop, ensuring the whole cross-section of the pile is wetted without loss of liquid from the sides. The liquid must be applied over the shortest possible length of the pile consistent with avoiding loss from the sides. This



Dimensions shown are in millimetres (mm)

Length of mold: 250 mm

FIG. 2—Powder train mold.

portion of the test is not applicable to metal powders.

Ignite one end of the pile. When the pile has burned a distance of 80 mm, measure the rate of burning over the next 100 mm. Note whether or not the wetted zone stops propagation of the flame. The test is performed six times using a clean cool plate each time, unless a positive result is observed earlier.

#### Criteria for Classification

Powdered, granular or pasty materials are classified in Division 4.1 when the time of burning of one or more of the test runs, according to the test method described in the above, is less than 45 s or the rate of burning is more than 2.2 mm/s.

Powders of metals or metal alloys are classified when they can be ignited and the reaction spreads over the whole length of the sample in 10 minutes or less.

#### Assignment of Packing Groups

**Combustible solids (other than metal powders).** Packing Group II is assigned if the burning time is less than 45 s and the flame passes the wetted zone. Packing Group III is assigned if the burning time is less than 45 s and the wetted zone stops the flame propagation for at least 4 minutes.

**Powders of metal or metal alloys.** Packing Group II is assigned if the zone of reaction spreads over the whole sample in 5 minutes or less. Packing Group III is assigned if the reaction spreads over the whole length of the sample in more than 5 minutes.

Solids which may cause or contribute to fire through friction are classified in Division 4.1 by analogy with existing entries. The packing group for solids which may cause or contribute to a fire through friction is assigned by comparison with existing classifications or in accordance with any appropriate special provision.

### 1.11.2 Division 4.2—Materials Liable to Spontaneous Combustion

#### *Pyrophoric Materials*

*Test method for solid pyrophoric materials.* One to two cm<sup>3</sup> of the powdery material to be tested is poured from about 1 m height onto a non-combustible surface and it is observed whether the material ignites during dropping or within 5 minutes of settling. This procedure is repeated six times unless a positive result is obtained earlier.

*Test Method for Liquid Pyrophoric Materials. Part 1:* A porcelain cup of about 10 cm diameter is filled with diatomaceous earth or silica gel at room temperature to a height of about 5 mm. Approximately 5 mL of the liquid to be tested is poured into the prepared porcelain cup and it is observed if the material ignites within 5 minutes. This procedure is repeated six times unless a positive result is obtained earlier.

*Part 2:* A 0.5 mL test sample is delivered from a syringe to an indented dry No. 3 Whatman filter paper. The test is conducted at 25 +/- 2°C and a relative humidity of 50 +/- 5 percent. Observations are made to see if ignition or charring occurs on the filter paper within five minutes after the liquid to be tested is introduced. This procedure is repeated three times using fresh filter paper each time unless a positive result is obtained earlier.

*Criterion for classification. Solid material.* If the sample ignites in one of the tests, the material is considered pyrophoric and should be classified in Division 4.2.

*Liquid material.* If the liquid ignites in part 1 of the test, or if it ignites or chars the filter paper in part 2 of the test, it is considered to be pyrophoric and should be classified in Division 4.2.

*Assignment of packing group.* Packing Group I is assigned to all pyrophoric solids and liquids.

#### *Self-Heating Materials.*

##### *Test Method for Self-Heating Materials*

A hot air circulating type of oven with an inner volume of more than 9 L and capable of controlling the internal temperature at 140 +/- 2°C is used.

Cubic sample containers of 2.5 cm and 10 cm side, made of stainless steel net with a mesh opening of 0.053 mm, with their top surface open, are used. Each container is housed in a cubic container cover made from a stainless steel net with a mesh opening of 0.595 mm and slightly larger than the sample container, so that the container fits in this cover. In order to avoid the effect of air circulation, another stainless steel cage, made from a net with a mesh opening of 0.595 mm and 15 × 15 × 25 cm in size, is further installed to house the cover.

Chromel-Alumel thermocouples of 0.3 mm diameter are used for temperature measurement. One is placed in the

center of the sample and another between the sample container and the oven wall. The temperatures are measured continuously.

The sample, powder or granular, in its commercial form, is filled to the brim of the sample container and the container tapped several times. If the sample settles, more is added. If the sample is heaped, it is leveled to the brim. The container is housed in the cover and cage, then hung at the center of the oven.

The oven temperature is raised to 140°C and kept there for 24 hours. The temperature of the sample is recorded. The first test is conducted with a 10 cm cube sample. Observations are made to determine if spontaneous ignition occurs or if the temperature of the sample exceeds 200°C. If negative results are obtained, no further test is necessary. If positive results are obtained, a second test is conducted with 2.5 cm cube sample to determine the data for packing group assignment.

#### *Criteria For Classification*

A self-heating material should be classified in Division 4.2 if in the first test using a 10-cm cube sample, spontaneous ignition occurs or the temperature of the sample exceeds 200°C during the 24-hour testing time. This criterion is based on the self-ignition temperature of charcoal, which is 50°C for a cubic volume of 27 m<sup>3</sup> and 140°C for a one-litre sample. Materials with self-ignition temperatures higher than 50°C for a cubic volume of 27 m<sup>3</sup> should not be classified in Division 4.2.

#### *Assignment of Packing Groups*

Packing Group II is assigned to materials which give positive results when tested with the 2.5 cm cube sample.

Packing Group III is assigned to materials which give positive results when tested with the 10-cm cube sample but which give a negative result with a 2.5-cm cube sample.

### 1.11.3 Division 4.3—Dangerous When Wet Materials

The following test method is used to determine whether the reaction of a material with water leads to the development of a dangerous amount of gases which may be flammable or toxic. The test method can be applied to solid and liquid materials. It is not applicable to pyrophoric materials.

#### *Test Method*

The material should be tested at a temperature of 20°C and atmospheric pressure by bringing it into contact with water. For a solid material, the package should be inspected for any particles < 500 μm diameter. If that powder constitutes more than 1 percent (mass) of the total or if the material is friable, then the whole of the sample should be ground to a powder before testing to allow for a reduction in particle size during handling and transport, otherwise the material should be tested in its commercial state. The testing should be performed three times. If spontaneous ignition of the gas occurs at any step, the material is classified in Division 4.3, and no further testing is necessary.

A small quantity (approximately 2 mm diameter) of the test material is placed in a trough of distilled water at 20°C. It is noted whether any gas is evolved and if it spontaneously ignites.

A small quantity of the test material (approximately 2 mm diameter) is placed in the center of a filter paper which is floated flat on the surface of distilled water at 20°C in a 100 mm diameter evaporating dish. The filter paper is to keep the material in one place, under which condition the likelihood of spontaneous ignition of any gas is greatest. It is noted whether any gas is evolved and if it spontaneously ignites.

The test material is made into a pile approximately 2 cm high and 3 cm in diameter with an indentation in the top. A few drops of water are added to the hollow. It is noted whether any gas is evolved and if it spontaneously ignites.

Water is put into the dropping funnel and enough of the material (up to a maximum weight of 25 g) to produce between 100 cm<sup>3</sup> and 250 cm<sup>3</sup> of gas is weighed and placed in a conical flask. The tap of the dropping funnel is opened to let the water into the conical flask and a stop watch is started. The volume of gas evolved is measured by any suitable means. The time taken for all the gas to be evolved is noted and, where possible, intermediate readings are taken. The rate of evolution of gas is calculated over 7 hours at 1-hour intervals. If the rate of evolution is erratic or is increasing after 7 hours, the measuring time should be extended to a maximum time of 5 days. The 5-day test may be stopped if the rate of evolution becomes steady or continually decreases and sufficient data have been established to assign a packing group to the material or to determine that the material should not be classified in Division 4.3. If the chemical identity of the gas is unknown, the gas should be tested for flammability and toxicity.

#### *Criteria for Classification*

A material should be classified in Division 4.3 if: 1) spontaneous ignition takes place in any step of the test procedure, or 2) there is an evolution of a flammable or toxic gas at a rate greater than 1 litre per kilogram of the material per hour.

#### *Assignment of Packing Groups*

Packing Group I is assigned to any material which reacts vigorously with water at ambient temperatures and demonstrates generally a tendency for the gas produced to ignite spontaneously, or which reacts readily with water at ambient temperatures such that the rate of evolution of flammable or toxic gas is equal to or greater than 10 litres per kilogram of material over any 1 minute.

Packing Group II is assigned to any material which reacts readily with water at ambient temperatures such that the maximum rate of evolution of flammable or toxic gas is equal to or greater than 20 litres per kilogram of material per hour, and which does not meet the criteria for Packing Group I.

Packing Group III is assigned to any material which reacts slowly with water at ambient temperatures such that the maximum rate of evolution of flammable or toxic gas is

greater than 1 litre per kilogram of material per hours and which does not meet the criteria for Packing Groups I or II.

### **1.12 Appendix F to Part 173—Guidelines for the Classification and Packing Group Assignment of Division 5.1 Materials**

#### *Introduction*

This test method is designed to measure the potential for a solid substance to increase the burning rate or burning intensity of a combustible substance when the two are thoroughly mixed. Two tests are run in triplicate for each substance to be evaluated, one at a 1- to 1- ratio, by mass, of the sample to sawdust and one at a 4- to 1- ratio, by mass, of the sample to sawdust. To determine whether a material should be in Division 5.1, the burning characteristics of each mixture are compared with a standard having a 1- to 1- ratio, by mass, of ammonium persulfate and sawdust. If a material is classified in Division 5.1, the packing group is determined using the same method, with potassium perchlorate and potassium bromate substituted for ammonium persulfate as appropriate.

#### *Procedure*

Ammonium persulfate, potassium perchlorate, and potassium bromate are reference substances. These substances should pass through a sieve mesh size smaller than 0.3 mm and should not be ground. Dry the reference substances at 65°C for 12 hours and keep in a desiccator until required.

The combustible material for this test is softwood sawdust. It should pass through a sieve mesh smaller than 1.6 mm and should contain less than 5 percent of water by weight. If necessary, spread it in a layer less than 25 mm thick, dry for 4 hours and keep in a desiccator until required.

Prepare a 30.0  $\pm$  0.1 g mixture of the reference substance and sawdust in a 1- to 1- ratio, by mass. Two 30.0  $\pm$  0.1 g mixtures of the material to be tested, in the particle size in which it is to be transported, and the sawdust, are prepared in ratios of 1-to-1, by mass and 4-to-1 by mass. Each mixture should be mixed mechanically without excessive stress as thoroughly as possible.

The test should be conducted in a ventilated area under the following ambient conditions:

temperature 20°C  $\pm$  5°C

humidity 50 percent  $\pm$  10 percent

Form each of the mixtures into a conical pile with dimensions of approximately 70-mm base diameter and 60-mm height on a cool, impervious, low-heat-conducting surface. Ignite the pile by means of a wire of inert metal in the form of a circular loop 40 mm in diameter positioned inside the pile 1 mm above the test surface. Heat the wire electrically to 1000°C until the first sign of combustion is observed or it is clear that the pile cannot be ignited. Turn off the electrical power used to heat the wire as soon as there is combustion.

Record the time from the first observable sign of combustion to the end of all reaction: smoke, flame, incandescence.

Repeat the test three times for each of the two mixing ratios.

### Criteria for Classification

A substance should be classified in Division 5.1 if, in either concentration tested, the mean burning time of the sawdust, established from three tests, is equal to or less than that of the average of the three tests with ammonium persulfate mixture.

### Assignment of Packing Group

Packing Group I is assigned to any substance which, in either mixture ratio tested, exhibits a burning time less than potassium bromate.

Packing Group II is assigned to any substance which, in either mixture ratio tested, exhibits a burning time equal to or less than that of potassium perchlorate and the criteria for Packing Group I are not met.

Packing Group III is assigned to any substance which, in either concentration tested, exhibits a burn time equal to or less than that of ammonium persulfate and the criteria for Packing Groups I and II are not met.

## 2. 46 CFR, U.S. COAST GUARD

### 2.1 Bulk Shipments

#### Shipping (30.10)

**Combustible liquid**—The term “combustible liquid” means any liquid having a flash point above 26.7°C (80°F) (as determined from an open-cup tester, as used for test of burning oils). In the regulations of this subchapter, combustible liquids are referred to by grades, as follows:

**Grade D**—any combustible liquid having a flash point below 65.6°C (150°F) and above 26.7°C (80°F).

**Grade E**—any combustible liquid having a flash point of 65.6°C (150°F) or above.

**Flammable or inflammable**—The words “flammable” and “inflammable” are interchangeable or synonymous terms for the purpose of the regulations in this subchapter.

**Flammable liquid**—The term “flammable liquid” means any liquid which gives off flammable vapors (as determined by flash point from an open-cup tester, as used for test of burning oils) at or below a temperature of 26.7°C (80°F). Flammable liquids are referred to by grades as follows:

**Grade A**—any flammable liquid having a Reid vapor pressure of 14 psia or more, as specified in ASTM Test Method D 323, *Method of Test for Vapor Pressure of Petroleum (Reid Method)*.

**Grade B**—any flammable liquid having a Reid vapor pressure under 14 psia and over 8½ psia.

**Grade C**—any flammable liquid having a Reid vapor pressure of 8½ psia or less and a flash point of 26.7°C (80°F) or below.

**Flash point**—The term “flash point” indicates the temperature at which a liquid gives off a flammable vapor when heated in an open-cup tester. For the purpose of the regulations in this subchapter, flash points determined by the testing methods will be equivalent to those determined with

an open-cup tester, as listed in the Table below (from paragraph 30.10.27).

Equivalent Flash Point in °F (°C)		
Open-cup tester	Tag closed-cup tester (ASTM D 56)	Pensky-Martens Closed Tester (ASTM D 93)
80 (27)	75 (24)	...
150 (66)	...	140 (60)

### 2.2 Commercial Fishing—Vessels Used to Transport Petroleum Products

#### Definitions (105.10)

**Combustible liquid**—The term “combustible liquid” means any liquid having a flash point above 26.7°C (80°F) (as determined from an open-cup tester, as used for test of burning oils). In the regulations of this part, combustible liquids are referred to by grades as follows:

**Grade D**—any combustible liquid having a flash point below 65.6°C (150°F) and above 26.7°C (80°F).

**Grade E**—any combustible liquid having a flash point of 65.6°C (150°F) or above.

**Flammable liquid**—The term “flammable liquid” means any liquid which gives off flammable vapors (as determined by flash point from an open-cup tester, as used for test of burning oils) at or below a temperature of 26.7°C (80°F). Flammable liquids are referred to by grades as follows:

**Grade A**—any flammable liquid having a Reid vapor pressure of 14 psia or more.

**Grade B**—any flammable liquid having a Reid vapor pressure under 14 psia and over 8½ psia.

**Grade C**—any flammable liquid having a Reid vapor pressure of 8½ psia or less and a flash point of 26.7°C (80°F) or below.

### 2.3 Hazardous Ships Stores (Part 147)

#### Definitions (147.3)

As used in this part:

**Accommodation, control, or service spaces** means living quarters, including walkways, dining rooms, galleys, pantries, lounges, lavatories, cabins, staterooms, offices, hospitals, cinemas, and game and hobby rooms; areas containing controls for equipment and navigation; workshops, other than those forming part of machinery spaces; and store rooms adjacent to these spaces.

**Combustible liquid** means *combustible liquid* as the term is defined in 49 CFR 173.120(b) (1991).

**Compressed gas** means *compressed gas* as the term is defined in 49 CFR 173.115 (1991).

**Consumer commodity** means a commodity, such as a polish, insecticide, cleaning compound, or distillate, that is packaged and distributed in a form and quantity intended for sale through retail sales establishments.

**Flammable liquid** means *flammable liquid* as the term is defined in 49 CFR 173.120 (1991).

**Hazardous material** means *hazardous material* as the term is defined in 49 CFR 171.8.

*Hazardous ships' stores* means ships' stores that are hazardous materials.

*Ships' stores* means materials which are on board a vessel for the upkeep, maintenance, safety, operation, or navigation of the vessel.

### Hazardous Ships' Stores Permitted on Board Vessels (147.15)

Unless prohibited under subpart B of this part, any hazardous material may be on board a vessel as ships' stores if the material:

- (a) Is labeled according to § 147.30; and
- (b) Meets the requirements, if any, in subpart B of this part applicable to the material.

### Labeling (147.30)

(a) Except as provided in paragraph (b) of this section, all immediate receptacles, containers, or packages containing hazardous ships' stores must be labeled in English with the following information concerning the contents:

- (1) Technical name or proper shipping name.
- (2) For hazardous ships' stores other than liquid fuels, manufacturer's or supplier's name and address.
- (3) Hazard classification under 49 CFR 172.101 and 173.2.
- (4) For hazardous ships' stores other than liquid fuels, step by step procedures for proper use.
- (5) First aid instructions in the event of personnel contact, including antidotes in the event of ingestion.
- (6) Stowage and segregation requirements.
- (b) Hazardous ships' stores that are consumer commodities labeled in accordance with the Federal Hazardous Substances Act Regulations in 16 CFR Part 1500 need not be labeled as specified in paragraph (a) of this section.

### Chemical Stores (194.05-3)

(a) Chemical stores are those chemicals which possess one or more of the following properties and shall be classed, marked, and labeled in accordance with 49 CFR part 172:

- (1) Explosives.
- (2) Flammable liquids.
- (3) Flammable solids.
- (4) Oxidizing materials.
- (5) Corrosive materials.
- (6) Compressed gasses.
- (7) Poisons.
- (8) Combustible liquids.
- (9) Other Regulated Materials (DOT Hazard Class "ORM").

### Chemicals in the Chemistry Laboratory (194.05-5)

(a) Small working quantities of chemical stores in the chemistry laboratory which have been removed from the approved shipping container need not be marked or labeled

as required by 49 CFR part 172. Reagent containers in the laboratory shall be marked to show at least the following:

- (1) Common chemical name.
- (2) Hazards, if any; e.g., flammable, poison, etc.

(b) In the interest of facilitating scientific activities, no restrictions are intended which will limit the variety of chemical stores which may be used in the chemical laboratory. With the knowledge and approval of the master, the laboratory supervisor may be responsible for stowage and use of materials within the laboratory and chemical store-room.

(c) Reagent containers shall be properly secured against shifting and spillage. Insofar as practical all reagents shall be stowed in suitable, unbreakable containers.

American Society for Testing Materials Standard D 323 (most recent revision), Method of Test for Vapor Pressure of Petroleum Products (Reid Method).

### Detail Requirements (194)

*Flammable liquid chemical stores*—Flammable liquids as chemical stores and reagents are governed by Subparts 194.15 and 194.20. Other flammable liquids are regulated by the appropriate portions of Subpart 146.21 of Part 146 or Part 147 of Subchapter N (Dangerous Cargoes) of this chapter.

*Flammable solids and oxidizing materials*—Flammable solids and oxidizing materials used as chemical stores and reagents are governed by Subparts 194.15 and 194.20. Oxidizing materials used as blasting agents are regulated by the appropriate portions of Subpart 149.22 or Part 146 of Subchapter N (Dangerous Cargoes) of this chapter.

*Combustible liquids as chemical stores*—Combustible liquid chemical stores and reagents shall be governed by Subparts 194.15 and 194.20. Other combustible liquids shall be regulated by the appropriate portions of Subpart 146.26 of Part 146 or Part 147 of Subchapter N (Dangerous Cargoes) of this chapter.

## 3. 33 CFR, U.S. COAST GUARD, ST. LAWRENCE SHIPPING

### 3.1 Navigation and Navigable Waters

#### *Hazardous Cargo Vessels (401.69)*

For the purpose of these regulations, a vessel shall be deemed to be a hazardous cargo vessel in the following cases:

- A tanker carrying fuel oil, gasoline, crude oil or other flammable liquids in bulk, having a flash point below 61°C (141.8°F), including a tanker that is not gas free where its previous cargo had a flash point below 61°C (141.8°F); or
- a tanker carrying compressed liquefied gases, bulk acids or liquefied chemicals in the following classes:

*IMO Class 2*—in excess of 50 tonnes of gases, compressed, liquefied or dissolved under pressure;

*IMO Class 3*—in excess of 50 tonnes of flammable liquids having a flash point below 61°C (141.80°F); and

*IMO Class 4*—in excess of 50 tonnes of flammable solids, spontaneously combustible material or substances emitting in excess of 50 tonnes of oxidizing substances or organic peroxides.



#### 4. 29 CFR, U.S. DEPARTMENT OF LABOR (PART B), OCCUPATIONAL SAFETY AND HEALTH ADMINISTRATION (OSHA)—INDUSTRIAL PLANTS (LABOR)

##### 4.1 Flammable and Combustible Liquids (1910.106)

###### *Definitions as Used in This Section*

**Aerosol**—Shall mean a material which is dispensed from its container as a mist, spray, or foam by a propellant under pressure.

**Boiling point**—Shall mean the boiling point of a liquid at a pressure of 14.7 psia (760 mm). Where an accurate boiling point is unavailable for the material in question, or for mixtures which do not have a constant boiling point, for purposes of this section the 10 percent point of a distillation performed in accordance with ASTM Standard Method for Distillation of Petroleum Products (D 86) may be used as the boiling point of liquid.

**Crude petroleum**—Shall mean hydrocarbon mixtures that have a flash point below 65.6°C (150°F) and which have not been processed in a refinery.

**Flammable aerosol**—Shall mean an aerosol which is required to be labeled “Flammable” under the Federal Hazardous Substances Labeling Act (15 U.S.C. 1261). For the purpose of paragraph (a) of this section, such aerosols are considered Class 1A liquids.

**Flash point**—Means the minimum temperature at which a liquid gives off vapor within a test vessel in sufficient concentration to form an ignitable mixture with air near the surface of the liquid, and shall be determined as follows:

- For a liquid which has a viscosity of less than 45 SUS at 37.8°C (100°F), does not contain suspended solids, and does not have a tendency to form a surface film while under test, the procedure specified in ASTM Test Method D 56 shall be used.
- For a liquid which has a viscosity of 45 SUS or more at 37.8°C (100°F), or contains suspended solids, or has a tendency to form a surface film while under test, ASTM Test Method D 93 shall be used, except that the methods specified in Note 1 to section 1.1 of ASTM D-93 may be used for the respective materials specified in the Note.
- For a liquid that is a mixture of compounds that have different volatilities and flash points, its flash point shall be determined by using the procedure specified in ASTM Methods D 56 or D 93 (See Chapter 2) on the liquid in the form it is shipped. If the flash point, as determined by this test, is 37.8°C (100°F) or higher, an additional flash point determination shall be run on a sample of the liquid evaporated to 90 percent of its original volume, and the lower value of the two tests shall be considered the flash point of the material.
- Organic peroxides, which undergo autoaccelerating thermal decomposition, are excluded from any of the flash point determination methods specified above.

**Liquid**—Shall mean, for the purpose of this section, any material which has a fluidity greater than that of 300 penetration asphalt when tested in accordance with ASTM Test

Method D 5. When not otherwise identified, the term liquid shall include both flammable and combustible liquids.

**Combustible liquid**—Means any liquid having a flashpoint at or above 37.8°C (100°F). Combustible liquids shall be divided into two classes as follows:

**Class II**—shall include those with flash points at or above 37.8°C (100°F) and below 60°C (140°F), except any mixture having components with flash points of 93.3°C (200°F) or higher, the volume of which make up 99 percent or more of the total volume of the mixture.

**Class III**—shall include those with flash points at or above 60°C (140°F). Class III liquids are subdivided into two subclasses as follows: 1) Class IIIA liquids shall include those with flash points at or above 60°C (140°F) and below 93.3°C (200°F), except any mixture having components with flash points of 93.3°C (200°F), or higher, the total volume of which make up 99 percent or more of the total volume of the mixture; and 2) Class IIIB liquids shall include those with flash points at or above 93.3°C (200°F). This section does not cover Class IIIB liquids. Where the term Class III liquids is used in this section it shall mean only Class IIIA liquids.

When a combustible liquid is heated for use to within 16.7°C (30°F) of its flash point, it shall be handled in accordance with the requirements for the next lower class of liquids.

**Flammable liquid**—Means any liquid having a flash point below 37.8°C (100°F), except any mixture having components with flash points of 37.8°C (100°F) or higher, the total of which make up 99 percent or more of the total volume of the mixture. Flammable liquids shall be known as Class I liquids. Class I liquids are divided into three classes as follows: 1) Class IA shall include liquids having flash points below 22.8°C (73°F) and having a boiling point below 37.8°C (100°F); 2) Class IB shall include liquids having flash points below 22.8°C (73°F) and having a boiling point at or above 37.8°C (100°F); and 3) Class IC shall include liquids having flash points at or above 22.8°C (73°F) and below 37.8°C (100°F).

**Vapor pressure**—Means the pressure, measured in psia exerted by a volatile liquid as determined by ASTM Test Method D 323.

**Ventilation**—As specified in this section, is for the prevention of fire and explosion. It is considered adequate if it is sufficient to prevent accumulation of significant quantities of vapor-air mixtures in concentration over one-fourth of the lower flammable limit.

**SUS**—Means Saybolt Universal Seconds as determined by ASTM Test Method D 88 and may be determined by use of the SUS conversion tables specified in ASTM Test Method D 2161 following determination of viscosity in accordance with the procedures specified in ASTM Test Method D 445.

**Viscous**—Means a viscosity of 45 SUS or more.

**NOTE**—OSHA through its Program Directive recognizes the use of the Setaflash tester and ASTM Test Method D 3278 for testing flammable and combustible liquids.

##### 4.2 Hazard Communication (1910.1200)

The Hazard Communication Section (1910.1200) was developed to protect workers in the Chemical Industry. It applies to laboratories as outlined below.

### Purpose

The purpose of this section is to ensure that the hazards of all chemicals produced or imported are evaluated, and that information concerning their hazards is transmitted to affected employers and employees within the manufacturing sector. This transmittal of information is to be accomplished by means of comprehensive hazard communication programs, which are to include container labeling and other forms of warning, material safety data sheets and employee training.

This occupational safety and health standard is intended to address comprehensively the issue of evaluating the potential hazards of chemicals, and communicating information concerning hazards and appropriate protective measures to employees, and to preempt any legal requirements of a state, or political subdivision of a state, pertaining to the subject. Evaluating the potential hazards of chemicals, and communicating information concerning hazards and appropriate protective measures to employees, may include, for example, but is not limited to, provisions for: developing and maintaining a written hazard communication program for the workplace, including lists of hazardous chemicals present; labeling of containers of chemicals in the workplace, as well as of containers of chemicals being shipped to other workplaces; preparation and distribution of material safety data sheets to employees and downstream employers; and development and implementation of employee training programs regarding hazards of chemicals and protective measures. Under Section 18 of the Occupational Safety and Health Act, no state or political subdivision of a state may adopt or enforce, through any court or agency, any requirement relating to the issue addressed by this Federal standard, except pursuant to a Federally-approved state plan.

### Scope and Application

This section requires chemical manufacturers or importers to assess the hazards of chemicals which they produce or import, and all employers to provide information to their employees about the hazardous chemicals to which they are exposed, by means of a hazard communication program, labels and other forms of warning, material safety data sheets, and information and training. In addition, this section requires distributors to transmit the required information to employers.

### Definitions

**Combustible liquid**—Means any liquid having a flash point at or above 37.8°C (100°F), but below 93.3°C (200°F), except any mixture having components with flash points of 93.3°C (200°F), or higher, the total volume of which make up 99 percent or more of the total volume of the mixture.

**Compressed gas**—Means a gas or mixture of gases having, in a container, an absolute pressure exceeding 40 psia at 21.1°C (70°F); or a gas or mixture of gases having, in a container, pressure exceeding 104 psia at 54.4°C (130°F) regardless of the pressure at 21.1°C (70°F); or a liquid having an absolute vapor pressure exceeding 40 psia at 37.8°C (100°F) as determined by ASTM Test Method D 323.

**Flammable**—Means a chemical that falls into one of the following categories: 1) *aerosol, flammable* means an aerosol

that, when tested by the method described in 16 CFR 1500.45 (see Section 8.4 of this chapter), yields a flame projection exceeding 18 in. (457 mm) at full valve opening, or a flash-back (a flame extending back to the valve) at any degree of valve opening; 2) *gas, flammable* means a gas that, at ambient temperature and pressure, forms a flammable mixture with air at a concentration of 13 percent by volume or less, or a gas that, at ambient temperature and pressure, forms a range of flammable mixture with air wider than 12 percent by volume, regardless of the lower limit; 3) *liquid, flammable* means any liquid having a flash point below 37.8°C (100°F), except any mixture having components with flash points of 37.8°C (100°F) or higher, the total of which make up 99 percent or more of the total volume of the mixture; and 4) *solid, flammable* means a solid, other than a blasting agent or explosive that is liable to cause fire through friction, absorption of moisture, spontaneous chemical change, or retained heat from manufacturing or processing, or which can be ignited readily and when ignited burns so vigorously and persistently as to create a serious hazard. A chemical shall be considered to be a flammable solid if, when tested by the method described in 16 CFR 1500.44 (see Section 8.3 of this chapter), it ignites and burns with a self-sustained flame at a rate greater than 1/10 in./s along its major axis.

**Flash Point**—Means the minimum temperature at which a liquid gives off a vapor in sufficient concentration to ignite when tested as follows:

(1) *Tag Closed Tester*—see American National Standard Method of Test for Flash Point by Tag Closed Tester, Z11.24, or ASTM Test Method D 56 for liquids with a viscosity of less than 45 SUS at 37.8°C (100°F), that do not contain suspended solids and do not have a tendency to form a surface film under test; or

(2) *Pensky-Martens Closed Tester*—(see American National Standard Method of Test for Flash Point by Pensky-Martens Closed Tester, Z11.7, or ASTM Test Method D 93 for liquids with a viscosity equal to or greater than 45 SUS at 37.8°C (100°F), or that contain suspended solids, or that have a tendency to form a surface film under test; or

(3) *Setaflash Closed Tester*—see American National Standard Method of Test for Flash Point by Setaflash Closed Tester or ASTM Test Method D 3278.

Organic peroxides, which undergo autoaccelerating thermal decomposition, are excluded from any of the flash point determination methods specified above.

**Organic peroxide**—Means an organic compound that contains the bivalent O-O structure and which may be considered to be a structural derivative of hydrogen peroxide where one or both of the hydrogen atoms has been replaced by an organic radical.

**Oxidizer**—Means a chemical other than a blasting agent or explosive that initiates or promotes combustion in other materials, thereby causing fire either of itself or through the release of oxygen or other gases.

**Pryophoric**—Means a chemical that will ignite spontaneously in air at a temperature of 54.4°C (130°F) or below.

**Unstable (reactive)**—Means a chemical which is the pure state, or as produced or transported, will vigorously poly-

merize, decompose, condense, or will become self-reactive under conditions of shocks, pressure, or temperature.

*Water-reactive*—Means a chemical that reacts with water to release a gas that is either flammable or presents a health hazard.

Readers should consult the full text of 29 CFR, Section 1910.1200 for other items, such as: limitations; development of a chemical hygiene plan; monitoring of employee exposure to hazards; employee information and training; hazard identification; and medical consultations and examinations.

### 4.3 Occupational Exposure to Hazardous Chemicals in Laboratories (1910.1450)

This section shall apply to all employers engaged in laboratory use of hazardous chemicals and physical hazards.

- (1) Employers shall ensure that labels on incoming containers of hazardous chemicals are not removed or defaced;
- (2) Employers shall maintain any material safety data sheets that are received with incoming shipments of hazardous chemicals, and ensure that they are readily accessible to laboratory employees; and
- (3) Employers shall ensure that laboratory employees are apprised of the hazards of the chemicals in their workplaces.

The following excerpt from 29 CFR, 1910.1450 gives definitions for "hazardous chemical," "physical hazard," "laboratory," "laboratory scale," and "protective laboratory practices and equipment." Definitions in 1910.1450 for physical hazards encountered in a laboratory, such as "combustible liquid," "flammable," "flash point," etc., are the same as those given in Section 1910.1200 above (Section 5.2 of this manual) and are not repeated below.

*Hazardous chemical*—Means a chemical for which there is statistically significant evidence based on at least one study conducted in accordance with established scientific principles that acute or chronic health effects may occur in exposed employees. The term "health hazard" includes chemicals which are carcinogens, toxic or highly toxic agents, reproductive toxins, irritants, corrosives, sensitizers, hepatotoxins, nephrotoxins, neurotoxins, agents which act on the hematopoietic systems, and agents which damage the lungs, skin, eyes, or mucous membranes.

*Physical hazard*—Means a chemical for which there is scientifically valid evidence that it is a combustible liquid, a compressed gas, explosive, flammable, an organic peroxide, an oxidizer, pyrophoric, unstable (reactive) or water-reactive.

*Laboratory*—Means a facility where the "laboratory use of hazardous chemicals" occurs. It is a workplace where relatively small quantities of hazardous chemicals are used on a non-production basis.

*Laboratory use of physical and chemical hazards*—Means handling or use of such chemicals in which all of the following conditions are met: 1) chemical manipulations are carried out on a "laboratory scale;" 2) multiple chemical procedures or chemicals are used; 3) the procedures involved are not part of a production process, nor in any way simulate a production process; and 4) "protective laboratory practices and equipment" are available and in common use to

minimize the potential for employee exposure to hazardous chemicals.

*Laboratory scale*—Means work with substances in which the containers used for reactions, transfers, and other handling of substances are designed to be easily and safely manipulated by one person. "Laboratory scale" excludes those workplaces whose function is to produce commercial quantities of materials.

*Protective laboratory practices and equipment*—Means those laboratory procedures, practices and equipment accepted by laboratory health and safety experts as effective, or that the employer can show to be effective, in minimizing the potential for employee exposure to hazardous chemicals.

Readers should consult the full text of 29 CFR 1910.1450 for other items, such as limitations; development of a chemical hygiene plan; monitoring of employee exposure to hazards; employee information and training; hazard identification; and medical consultations and examinations.

### 4.4 Shipyard Employment (1915)

#### Definitions

*Shipyard employment*—Means ship repairing, shipbuilding, shipbreaking and related employments.

*Ship repair and ship repairing*—Means any repair of a vessel including, but not restricted to, alterations, conversions, installations, cleaning, painting, and maintenance work.

*Shipbuilding*—Means the construction of a vessel including the installation of machinery and equipment.

*Hazardous material*—Means a material which has one or more of the following characteristics: 1) has a flash point below 60°C (140°F), closed cup or is subject to spontaneous heating; 2) has a threshold limit value below 500 ppm in the case of a gas or vapor, below 500 mg/m<sup>3</sup> for fumes, and below 25 mppcf in case of a dust; 3) has a single dose oral LD<sub>50</sub> below 500 mg/kg; 4) is subject to polymerization with the release of large amounts of energy; 5) is a strong oxidizing or reducing agent; 6) causes first degree burns to skin in short time exposure, or is systemically toxic by skin contact; or 7) in the course of normal operations, may produce dusts, gases, fumes, vapors, mists, or smokes which have one or more of the above characteristics.

#### Painting

*Paints and tank coatings dissolved in highly volatile, toxic and flammable solvents*—Several organic coatings, adhesives and resins are dissolved in highly toxic, flammable and explosive solvents with flash points below 26.7°C (80°F). Work involving such materials shall be done only when all of the following special precautions have been taken:

(1) Sufficient exhaust ventilation shall be provided to keep the concentration of solvent vapors below 10 percent of the lower explosive limit. Frequent tests shall be made by a competent person to ascertain the concentration.

(2) If the ventilation fails or if the concentration of solvent vapors rises above 10 percent of the lower explosive limit, painting shall be stopped and the compartment shall be evacuated until the concentration again falls below 10 percent of the lower explosive limit. If the concentration does not fall when painting is stopped, additional ventilation to

## 120 FLASH POINT STANDARDS AND THEIR USE

bring the concentration down to 10 percent of the lower explosive limit shall be provided. Ventilation shall be continued after the completion of painting until the space or compartment is gas free. The final determination as to whether the space or compartment is gas free shall be made after the ventilation equipment has been shut off for at least 10 min.

### *Health and Sanitation (1915.97)*

The provisions of this section shall apply to ship repairing, shipbuilding, and shipbreaking, except where indicated otherwise.

(a) The employer shall provide all necessary controls, and the employees shall be protected by suitable personal protective equipment against the hazards identified under 1915.90 of this part and those hazards for which specific precautions are required in Subparts B, C, and D of this part.

### *Hazard Communications (1915.99)*

This section contains the identical text of the revised 1910.1200. (See Section 4.2 of this chapter.)

### *Marine Terminals, Hazard Communication (1917.28)*

This section contains the identical text of the revised 1910.1200. See Section 4.2 of this chapter.

### *Safety and Health Regulations for Longshoring Hazard Communications (1918.90)*

This section contains the identical text of the revised 1910.1200. (See Section 4.2 of this chapter.)

## 5. 29 CFR, CONSTRUCTION INDUSTRY (SUBCHAPTER D)

### 5.1 Safety and Health Regulations for Construction Hazard Communications (1926)

This section contains the identical text of the revised 1910.1200 (1926.59). (See Section 4.2 of this chapter.)

#### *Definitions*

*Combustible liquids*—Means any liquid having a flash point at or above 60°C (140°F), and below 93.4°C (200°F).

*Combustion*—Means any chemical process that involves oxidation sufficient to produce light or heat.

*Flammable*—Means capable of being easily ignited, burning intensely, or having a rapid rate of flame spread.

*Flammable liquids*—Means any liquid having a flash point below 60°C (140°F) and having a vapor pressure not exceeding 40 psia at 37.8°C (100°F).

*Flash point of the liquid*—Means the temperature at which it gives off vapor sufficient to form an ignitable mixture with the air near the surface of the liquid or within the vessel used as determined by appropriate test procedure and apparatus. The flash point of liquids having a viscosity less than 45 SUS at 37.8°C (100°F) and a flash point below 79.4°C (175°F) shall be determined in accordance with ASTM Test Method D 56. The flash point of liquids having a viscosity of 45 SUS or more at 79.4°C (175°F) or higher shall be determined in accordance with ASTM Test Methods D 93.

*Vapor pressure*—Means the pressure, measured in psia, exerted by a volatile liquid as determined by ASTM Test Method D 323.

Occupational Safety and Health Standards for Agriculture applicable standards in 29 CFR Part 1910 (1928.21).

Hazard Communication contains the identical text of revised 1910.1200 (see Section 4.2 of this chapter).

## 6. 16 CFR, CONSUMER PRODUCT SAFETY COMMISSION (SUBCHAPTER C)

### 6.1 Commercial Practices (1500)

#### *Scope*

Set forth in this Subchapter C are the regulations of the Consumer Product Safety Commission issued pursuant to and for the implementation of the Federal Hazardous Substances Act (Pub. L. 86-613, 74 Stat. 372-81-15 U.S.C. 1261-74) as amended.

#### *Authority*

Authority under the Federal Hazardous Substances Act is vested in the Consumer Product Safety Commission by Section 30(a) of the Consumer Product Safety Act [15 U.S.C. 1261(1), 1269(a), and 2079(a)].

#### *Definitions*

*Act*—Means the Federal Hazardous Substances Act (Pub. L. 86-613, 74 Stat. 372-81-15 U.S.C. 1261-74) as amended.

*Hazardous substance*—Means any substance or mixture of substances which is toxic, corrosive, an irritant, a strong sensitizer, flammable or combustible, or generates pressure through decomposition, heat, or other means, if such substance or mixture of substances may cause substantial personal injury or substantial illness during or as a proximate result of any customary or reasonable foreseeable handling or use, including reasonably foreseeable ingestion by children.

*Extremely flammable*—Shall apply to any substance which has a flash point at or below  $-6.7^{\circ}\text{C}$  ( $20^{\circ}\text{F}$ ) as determined by the test method described in Section 6.2 of this chapter (1500.43a), except that, any mixture having one component or more with a flash point higher than  $-6.7^{\circ}\text{C}$  ( $20^{\circ}\text{F}$ ) which comprises at least 99 percent of the total volume of the mixture is not considered to be an extremely flammable substance.

*Flammable*—Shall apply to any substance having a flash point above  $-6.7^{\circ}\text{C}$  ( $20^{\circ}\text{F}$ ) and below  $37.8^{\circ}\text{C}$  ( $100^{\circ}\text{F}$ ), as determined by the test method described in Section 6.2 of this chapter (1500.43a), except that, any mixture having one component or more with a flash point at or above  $37.8^{\circ}\text{C}$  ( $100^{\circ}\text{F}$ ) which comprises at least 99 percent of the total volume of the mixture is not considered to be a flammable substance. In addition, any mixture containing 24 percent or less of water miscible alcohols, by volume, in aqueous solution is not considered to be flammable if the mixture does not present a significant flammability hazard when used by consumers.

*Combustible*—Shall apply to any substance having a flash point at or above  $37.8^{\circ}\text{C}$  ( $100^{\circ}\text{F}$ ) to and including  $65.6^{\circ}\text{C}$

(150°F) as determined by the test method described in Section 6.2 of this chapter (1500.43a), except that, any mixture having one component or more with a flash point higher than 65.6°C (150°F) which comprises at least 99 percent of the total volume of the mixture is not considered to be a combustible hazardous substance. In addition, any mixture containing 24 percent or less of water miscible alcohols, by volume, in aqueous solution is not considered to be combustible if the mixture does not present a significant flammability hazard when used by consumers.

**Flash point**—To determine flash point temperatures for purposes of enforcing and administering requirements of the Federal Hazardous Substances Act applicable to “extremely flammable,” “flammable,” and “combustible” hazardous substances, the Commission will follow the procedures in Section 6.2 of this chapter (1500.43a). However, the Commission will allow manufacturers and labelers of substances and products subject to those requirements to rely on properly conducted tests using the Tag Open-Cup Method (as published at 38 FR 27012, September 27, 1973, and set forth below), and the definitions of the terms “extremely flammable,” “flammable,” and “combustible” in this section before its amendment (as published at 38 FR 27012, September 27, 1973, and amended 38 FR 30105, November 1, 1973, set forth in the note following this section) if: 1) the substance or product was subject to and complied with the requirements of the Federal Hazardous Substances Act for “extremely flammable,” “flammable,” or “combustible” hazardous substances before September 27, 1973; and 2) no change has been made to the formulation or labeling of such substance or product after the effective date of 1500.43a, prescribing a closed-cup test apparatus and procedure.

**Extremely flammable solid**—Means a solid substance that ignites and burns at an ambient temperature of 26.7°C (80°F) or less when subjected to friction, percussion, or electrical spark.

**Flammable solid**—Means a solid substance that, when tested by the method described in Section 6.3 of this chapter (1500.44), ignites and burns with a self-sustained flame at a rate greater than 1/10 in. (2.5 mm) per s along its major axis.

**Extremely flammable contents of self-pressurized container**—Means contents of a self-pressurized container that, when tested by the method described in Section 6.4 of this chapter (1500.45), a flashback (a flame extending back to the dispenser) is obtained at any degree of valve opening and the flash point, when tested by the method described in Section 6.2 of this chapter (1500.43a), is less than -6.7°C (20°F).

**Flammable contents of self-pressurized container**—Means contents of a self-pressurized container that, when tested by the method described in Section 6.4 of this chapter (1500.45), a flame projection exceeding 18 in. (457 mm) is obtained at full valve opening or a flashback (a flame extending back to the dispenser) is obtained at any degree of valve opening.

**NOTE**—The definitions of “extremely flammable,” “flammable,” and “combustible” hazardous substances set forth above are effective August 10, 1987. The definitions remaining in effect until August 10, 1987, as published at 38 FR

27012, Sept. 27, 1973, and amended at 38 FR 30105, Nov. 1, 1973, are set forth below. Manufacturers and labelers of products subject to the Federal Hazardous Substances Act may continue to use these definitions for labeling of those products under the conditions set forth above.

**Extremely flammable (Pre-1987 version)**—Shall apply to any substance which has flash point at or below -6.7°C (20°F) as determined by the Tag Open-Cup Tester.

**Flammable (Pre-1987 version)**—Shall apply to any substance which has a flash point of above -6.7°C (20°F), up to and including 26.7°C (80°F), as determined by the Tag Open-Cup Tester.

**Combustible (Pre-1987 version)**—Shall apply to any substance which has a flash point above 26.7°C (80°F) up to and including 65.6°C (150°F), as determined by the Tag Open-Cup Tester; except that the flammability or combustibility of solids and of the contents of self-pressurized containers shall be determined by methods found by the Commission to be generally applicable to such materials or containers, respectively, and established by regulations issued by the Commission, which regulations shall also define the terms “flammable,” “combustible,” and “extremely flammable” in accordance with such methods.

**Extremely flammable**—Means any substance that has a flash point at or below -6.7°C (20°F) as determined by the test method described in Section 6.1 below (1500.43).

**Flammable**—Means any substance that has a flash point of above -6.7°C (20°F), up to and including 26.7°C (80°F), as determined by the test method described in Section 6.1 below (1500.43).

## 7. 16 CFR, FLASH POINT TESTING PROCEDURES, CPSC REGULATIONS

The Method of Test for Flash Point of Volatile Flammable Materials by Tag Open-Cup apparatus as published at 38 FR 27012, Sept. 27, 1973, is based on an old revision of ASTM Test Method D 1310.

### 7.1 Tag Open-Cup Method (1500.43)

#### Method of Test for Flash Point of Volatile Flammable Materials by Tag Open-Cup Apparatus (1500.43)

##### Scope

This method describes a test procedure for the determination of open-cup flash points of volatile flammable materials having flash points below 79.4°C (175°F).

This method, when applied to paints and resin solutions which tend to skin over or which are very viscous, gives less reproducible results than when applied to solvents.

Since this method is based on ASTM D 1310, *Test Method for Flash Point and Fire Points of Liquids by Tag Open-Cup Apparatus*, the reader is directed to Chapter 2, which contains a full reprint of that test method. However, if the substance is regulated by the tag open cup test, the method contained in 16 CFR 1500.43 shall be considered the referee method.

## 7.2 Method of Test for Flash Point of Volatile Flammable Materials (1500.43a)

### Scope

This method describes the test procedure which the Commission will use for the determination of the flash point of volatile flammable materials, using a Setaflash<sup>1</sup> low-range closed tester, or an apparatus producing equivalent results. The method described in this section is essentially a Setaflash equilibrium procedure which closely parallels ASTM Test Method D 3828. Manufacturers and labelers of products subject to labeling and other requirements under the Federal Hazardous Substances Act may use other apparatus and/or test methods which produce equivalent results.

At the option of the user, the procedures described in this section may be used to determine the actual flash point temperature of a sample or to determine whether a product will or will not flash at a specified temperature (flash/no flash).

If the substance to be tested has a viscosity greater than 150 Stokes at 25°C (77°F), see "Testing High-Viscosity Liquids," below, for modifications to the testing procedure.

If the Commission has reason to believe on the basis of reliable experience or other relevant information or data that the flammability classification based on the flash point temperature determined in accordance with this section and that the substance should be reclassified, the Commission will initiate a rulemaking proceeding for reclassification of the substance. Product manufacturers and labelers may use reliable experience or other relevant information or data in addition to the flash point temperature of a substance as a basis for compliance with any applicable requirements of the Federal Hazardous Substances Act in the absence of a rule issued by the Commission to reclassify the substance.

### Summary of Test Methods

**Method A—Flash/No Flash Test**—A specified volume of sample is introduced by a syringe into the cup of the apparatus that is set and maintained at the specified temperature. After a specific time a test flame is applied and an observation made as to whether or not flash occurred.

**Method B—Finite (or Actual) Flash Point**—A specified volume of sample is introduced into the cup of the apparatus that is maintained at the expected flash point. After a specified time, a test flame is applied and the observation is made whether or not a flash occurred.

The specimen is removed from the cup, the cup cleaned, and the cup temperature adjusted 5°C (9°F), lower or higher depending on whether or not a flash occurred previously. A fresh specimen is introduced and tested. This procedure is repeated until the flash point is established within 5°C (9°F).

The procedure is then repeated at 1°C (2°F) intervals until the flash point is determined to the nearest 1°C (2°F).

If improved accuracy is desired, the procedure is repeated at 0.5°C (1°F). The test procedures will be modified, where necessary, to ensure that the results obtained reflect the hazard of the substance under reasonably foreseeable conditions of use. Thus, for example, the material, if a mixture, will normally be tested as it comes from the container, and/

<sup>1</sup>Setafash is a registered trademark of Stanhope-Seta Limited, Park Close, Englefield Green, Egham, Surrey, England TW20 OXD.

or after a period of evaporation. The period of evaporation for a material which is a mixture will normally be the time required for the mixture to evaporate in an open beaker under ambient conditions to 90 percent of its original volume, or a period of 4 h, whichever occurs first. However, this period of evaporation will be changed if the results obtained do not represent the hazard of the substance under reasonably foreseeable conditions of use.

**NOTE**—The test procedures, definitions, test apparatus set ups, etc., in 1500.43a are the same, with minor wording and format variations, as those described in ASTM Test Methods D 3828. Since Test Methods D 3828 is fully reprinted in Chapter 2 of this manual, the flash point testing procedures need not be repeated here. The only essential differences between 1500.43a and D 3828 concern the testing of high-viscosity liquids. These paragraphs are, therefore, given below.

### Testing High-Viscosity Liquids

High-viscosity materials may be added to the cup by the following procedure:

Back load a 5- or 10-mL syringe with the sample to be tested and extrude 2 mL into the cup. Spread the specimen as evenly as possible over the bottom of the cup.

If the sample cannot be loaded into a syringe and extruded, other means of adding the sample to the cup may be used such as a spoon. Add approximately 2 mL of material to the spoon and then push the material from the spoon into the cup.

If the test specimen does not close the sampling port in the cup, seal the cup externally by suitable means.

Using the appropriate procedure, either Method A or Method B from ASTM Test Methods D 3828 (see Chapter 2), determine the flash point of the specimen which has been added to the tester in accordance with the above, except that the time specified is increased from 1 to 5 min for samples at or above ambient temperature.

## 7.3 Method for Determining Extremely Flammable and Flammable Solids (1500.44)

### Preparation of Samples

**Granules, powders, and pastes**—Pack the sample into a flat, rectangular metal boat with inner dimensions 6 in. long by 1 in. wide by ¼ in. deep (152 by 25 by 6.3 mm).

**Rigid and pliable solids**—Measure the dimensions of the sample and support it by means of metal ringstands, clamps, rings, or other suitable devices as needed, so that the major axis is oriented horizontally and the maximum surface is freely exposed to the atmosphere.

### Procedure

Place the prepared sample in a draft-free area that can be ventilated and cleared after each test. The temperature of the sample at the time of testing shall be between 20°C (68°F) and 30°C (86°F). Hold a burning paraffin candle whose diameter is at least 1 in. (25 mm), so that the flame is in contact with the surface of the sample at the end of the major axis for 5 s or until the sample ignites, whichever is less. Remove the candle. By means of a stopwatch, determine the time of combustion with self-sustained flame. Do not exceed 60 s.

Extinguish flame with a CO<sub>2</sub> or similar nondestructive type extinguisher. Measure the dimensions of the burnt area and calculate the rate of burning along the major axis of the sample.

#### 7.4 Method for Determining Extremely Flammable and Flammable Contents of Self-Pressurized Containers (1500.45)

##### Equipment Required

The test equipment consists of a base 8 in. wide by 2 ft. long (203 by 609 mm), marked in 6-in. (152 mm) intervals. A rule 2 ft long and marked in inches is supported horizontally on the side of the base and about 6 in. (152 mm) above it. A paraffin candle 1 in. (25 mm) or more in diameter, and of such height that the top third of the flame is at the height of the horizontal rule, is placed at the zero point in the base.

##### Procedure

The test is conducted in a draft-free area that can be ventilated and cleared after each test. Place the self-pressurized container at a distance of 6 in. (152 mm) from the flame source. Spray for periods of 15 to 20 s (one observer noting the extension of the flame and the other operating the container) through the top third of the flame and at a right angle to the flame. The height of the flame should be approximately 2 in. (51 mm). Take three readings for each test, and average. As a precaution do not spray large quantities in a small, confined space. Free space of previously discharged material.

#### 7.5 Method for Determining Flash Point of Extremely Flammable Contents of Self-Pressurized Containers

Use the apparatus described in Section 7.2 above. Use some means such as dry ice in an open container to chill the pressurized container. Chill the container, the flash cup, and the bath solution of the apparatus (brine or glycol may be used) to a temperature of about -32°C (-25°F). Puncture the chilled container to exhaust the propellant. Transfer the chilled formulation to the test apparatus and test in accordance with the method described in Section 7.2 above.

### 8. 40 CFR, U.S. ENVIRONMENTAL PROTECTION AGENCY (PART D)

#### 8.1 Pesticides and Toxic Substances

*Pesticides (162.10)*—Physical or chemical hazards. Warning statements on the flammability or explosive characteristics of the pesticide are required as follows:

*Toxic Substances (761)*—Polychlorinated Biphenyls (PCBs) Manufacturing, Processing, Distribution in Commerce, and Use Prohibitions. References (761.19):

1. ASTM D 93, Test Method for Flash Point by Pensky-Martens Closed Tester.
2. ASTM D 3278, Test Method for Flash Point of Liquid by Setaflash Closed Tester.

Flash point	Required test
<b>(A) PRESSURIZED CONTAINER</b>	
Flash point at or below -6.7°C (20°F); if there is a flashback at any valve opening	Extremely flammable. Contents under pressure. Keep away from fire, sparks, and heated surfaces. Do not puncture or incinerate container. Exposure to temperatures above 130°F may cause bursting.
Flash point above -6.7°C (20°F) and not over 26.7°C (80°F) or if the flame extension is more than 18 in. long at a distance of 6 in. from the flame	Flammable. Contents under pressure. Keep away from heat, sparks, and open flame. Do not puncture or incinerate container. Exposure to temperatures above 130°F may cause bursting.
All other pressurized containers	Contents under pressure. Do not use or store near heat or open flame. Do not puncture or incinerate container. Exposure to temperatures above 130°F may cause bursting.
<b>(B) NONPRESSURIZED CONTAINERS</b>	
At or below -6.7°C (20°F)	Extremely flammable. Keep away from fire, sparks, and heated surfaces.
Above -6.7°C (20°F) and not over 26.7°C (80°F)	Flammable. Keep away from heat and open flame.
Above 26.7°C (80°F) and not over 65.5°C (150°F)	Do not use or store near heat or open flame.

*Disposal Requirements (761.60)*—Prior to any person burning these liquids in the boiler, approval must be obtained from the EPA Regional Administrator for the EPA region in which the boiler is located and any persons seeking such approval must submit to the EPA Regional Administrator a request containing among other items the following.

The concentration of PCBs and of any other chlorinated hydrocarbon in the waste and the results of analysis using the following ASTM Test Methods:

D 3178, *Test Method for Carbon and Hydrogen in the Analysis Sample of Coal and Coke*, to determine carbon and hydrogen content; E 258, *Test Method for Total Nitrogen in Organic Materials by Modified Kjeldahl Method*, to determine nitrogen content; D 2784, *Test Method for Sulfur in Liquefied Petroleum Gases Oxy-Hydrogen Burner or Lamp*, D 1266, *Test Method for Sulfur in Petroleum Products (Lamp Method)*, or D 129, *Test Method for Sulfur in Petroleum Products (General Bomb Method)*, to determine sulfur content; D 808, *Test Method for Chlorine in New and Used Petroleum Products (Bomb Method)*, to determine chlorine content; D 2709, *Test Method for Water and Sediment in Distillate Fuels by Centrifuge* or D 1796, *Test Method for Water and Sediment in Fuel Oils by the Centrifuge Method (Laboratory Procedure)*, to determine water and sediment content; D 482, *Test Method for Ash from Petroleum Products*, to determine ash content; D 240, *Test Method for Heat of Combustion of Liquid Hydrocarbon Fuels by Bomb Calorimeter*, to determine calorific value; D 2158, *Test Method for Residues in Liquefied Petroleum (LP) Gases* or D 524, *Test Method for Ramsbottom Carbon Residue of Petroleum Products*, to determine carbon residue; and D 93, *Test Methods*

## 124 FLASH POINT STANDARDS AND THEIR USE

for *Flash Point by Pensky-Martens Closed Tester*, to determine flash point.

*Chemical Waste Landfills (761.75)*—Ignitable wastes shall not be disposed of in chemical waste landfills. Liquid ignitable wastes are wastes that have a flash point less than 60°C (140°F) as determined by ASTM Test Method D 93 or D 3278, or an equivalent method.

### 8.2 Office of Solid Waste

#### *Characteristic of Ignitability (261.21):*

A solid waste exhibits the characteristic of ignitability if a representative sample of the waste has any of the following properties:

It is a liquid, other than an aqueous solution containing less than 24 percent alcohol by volume and has a flash point less than 60°C (140°F), as determined by ASTM Test Method

D 93 or D 3278, or as determined by an equivalent test method approved by the Administrator under procedures set forth in 260.20 and 260.21.

It is not a liquid and is capable, under standard temperature and pressure, of causing fire through friction, absorption of moisture of spontaneous chemical changes and, when ignited, burns so vigorously and persistently that it creates a hazard.

It is an ignitable compressed gas as defined in 49 CFR 173.300 and as determined by the test methods described in that regulation or equivalent test methods approved by the Administrator under 260.20 and 260.21.

It is an oxidizer as defined in 49 CFR 173.151.

A solid waste that exhibits the characteristic of ignitability, but is not listed as a hazardous waste in Subpart D, has the EPA Hazardous Waste Number of D001.

1.49 CFR 173.300 has been removed from the DOT regulations; 49 CFR 173.151 no longer refers to oxidizers but to flammable solids. However, DOT regulations offer 49 CFR 173.115 for Hazardous Gas and 49 CFR 173.127 for oxidizers.



## **PART III: Flash Point Specifications and Standards of Other Countries (National Governments and Organizations)**

# Specifications of Other National Governments

## INTRODUCTION

The following jet fuel specifications give flash points for hydrocarbon fuels used in turbine aircraft and missiles. They were obtained from Exxon International Company's Bulletin, "Jet Fuel Specifications," 1990 edition, and are reprinted

here with permission from Exxon Company, International, Marketing/Distribution, 200 Park Ave., Florham Park, NJ 07932.

**TABLE 12-1—Australian Government Jet Fuel Specifications for Flash Point.**

Agency	Civil	Dept. of Defense
Specification	QTA K1/80	DEF 5208
Latest Revision Date	Sept. 1988	Oct. 1985
Grade Designation	Jet A-1	Avtur
Fuel Type	Kerosene	Kerosene
Flash Point °C (°F) min	38(100.4)	38(100.4) <sup>a</sup>
ASTM Flash Point Method	D 3828	D 3828
IP Flash Point Method	303/170	303/170

<sup>a</sup>In case of dispute, use IP 170 as reference method.

**TABLE 12-2—Brazilian Government Jet Fuel Specifications for Flash Point.**

Agency	National Council of Petroleum
Specification	QAV-1
Latest Revision Date	Nov. 1985
Fuel Type	Kerosene
Flash Point °C (°F) min	40 (104)
ASTM Flash Point Method	D 56
MB Flash Point Method <sup>a</sup>	NBR 7974

<sup>a</sup>Metodos Brasileiros (MB) da Associacao Brasileira de Normas Tecnicas e do Instituto Brasileiro de Petroleo.

**TABLE 12-3—Canadian Government Jet Fuel Specifications for Flash Point.**

Agency Specification	Canadian Government Specification Board	
	CAN/CGSB	3-GP-24 Mb
	3.23-M86 (Amd 2)	
Latest Revision Date	Nov. 1989	1990
Fuel Type	Kerosene	High Flash Kerosene
Flash Point °C (°F) min	38 (100.4) <sup>a</sup>	60 (140)
ASTM Flash Point Method	D 56, D 3828	D 93

<sup>a</sup> Specification also permits a low flash kerosene at 33°C (91.4°F) minimum, identified as Jet A-2.

**TABLE 12-4—French Government Jet Fuel Specifications for Flash Point.**

Agency Specification	French Ministry of the Armed Forces (AIR)	
	AIR 3405 D	AIR 3404C
Latest Revision Date	April 30, 1988	March 13, 1980
Fuel Type	Kerosene	High Flash Kerosene
Flash Point °C (°F) min	41 (105.8) <sup>a</sup>	60 (140)
ASTM Flash Point Method	D 93	D 93
NF Test Method <sup>b</sup>	M07-019	M07-019

<sup>a</sup>Minimum is 38°C (100.4°F) by NF M07-011 (Abel); NF M07-019 preferred.

<sup>b</sup>French Test Methods of the Association Francaise de Normalisation (NF).

**TABLE 12-5—Japanese Government Jet Fuel Specifications for Flash Point.**

Agency	MITI
Specification	JIS K2209-88
Latest Revision Date	April 1988
Grade Designation	Class 1, Class 2 <sup>a</sup>
Fuel Type	Kerosene
Flash Point °C (°F) min	38 (100.4)
ASTM Flash Point Test Method	D 56
JIS Test Method	K 2265

<sup>a</sup>Class 1 corresponds to Jet A-1, Class 2 to Jet A.

**TABLE 12-6**—Peoples Republic of China Jet Fuel Specifications for Flash Point.

Agency	PRC Ministry of Petroleum Industry Standards	
Specification	SY 1008-80	
Latest Revision Date	Oct. 1, 1980	
Grade Designation	RP-3	
Fuel Type	Kerosene	
Flash Point °C (°F) min	38 (100.4)	
GB Test Method		
Agency	PRC National Association for Standardization	
Specification	GB 438-77	GB 1788-79
Latest Revision Date	Dec. 1, 1977	July 1, 1980
Grade Designation	RP-1	RP-2
Fuel Type	Kerosene	Kerosene
Flash Point °C (°F)	28 (82.4)	28 (82.4)
GB Test Method	261	261

**TABLE 12-7**—Swedish Government Jet Fuel Specifications for Flash Point.

Agency	Swedish Defence Material Administration	
Specification	FSD-8607	
Latest Revision Date	March 1987	
Grade Designation	FLYGFOTOGEN 75	
Fuel Type	Kerosene	
Flash Point °C (°F)	38 (100.4)	
Institute of Petroleum Test Method	IP 170	

**TABLE 12-8**—United Kingdom Jet Fuel Specifications for Flash Point.

Agency	Ministry of Defence (Procurement Exec.)	
Specification	DERD 2494	DERD 2498
Latest Revision Date	June 1988	Amendment 1, Aug. 1980
Grade Designation	AVTUR	AVCAT
Fuel Type	Kerosene	High Flash Kerosene
Flash Point °C (°F) min	38 (100.4)	60 (140)
ASTM Flash Point Test Method	D 56, D 3828	D 93
IP Test Method	IP 170	IP 34

**TABLE 12-9**—USSR Government Turbine Fuel Specifications for Flash Point.

Agency	USSR Standards Organization			
	Specification	10227-86	10227-86	10227-86
Latest Revision Date	Nov. 1986	Nov. 1986	Nov. 1986	Nov. 1986
Grade Designation	T-1	TS-1	TS-1	RT
Fuel Type	Kerosene	Kerosene Regular	Kerosene Premium	Kerosene
Flash Point °C (°F)	30(86)	28 (82.4)	28 (82.4)	28 (82.4)
GOST Test Method <sup>a</sup>	6356-75	6356-75	6356-75	6356-75

<sup>a</sup>GOST Test Methods are generally similar to ASTM and IP methods.

# Flash Point Methods from National Standards Organizations of Other Countries

## INTRODUCTION

This Chapter lists the national standards by country with their standards organization and address. The acronym for each standard organization is shown in parentheses after the name of the country. The acronyms are generally used in the designation of the standards.

Each national standard organization acts as the sales agent in their respective countries for standards of their organization, of the International Organization for Standardization (ISO), and of other national standards organizations. These organizations are governmental institutions, organizations incorporated by public law, or have close links with the public administration in their countries.

Each organization develops standards by some form of consensus procedure. There are a variety of ways a country may use to determine when and by whom a standard should be prepared. Different sources are used by each country in developing standards, such as, ISO and CEN (European Committee for Standardization) or standards of another nation. There are also various procedures employed in obtaining approval of a standard. When the standardization process is controlled by the government, final approval is obtained from the governmental agency responsible. Most standards are designated with the acronym for the organization followed by a number and the title, e.g., BS 244 Turpentine for Paints, Type 1, Spirits of Turpentine. Where one country adopts the standard of another, the originating country's designation and title may be used. In cases where the standard of another country is modified, a reference is made to the original standard in the title of the modified one.

While not all of the standards organizations with their flash point standards are included in this chapter, names and addresses of all ISO member standards organizations are listed in Appendix C.

## 1. AUSTRALIA (AS/SAA)

**Standards Association of Australia, Standards House, 80-86 Authur St., North Sydney N.S.W. 2060, Australia.**

*AS 2106*—Methods for the Determination of the Flash-point of Flammable Liquids (Closed Cup).

Describes two procedures, the Abel Method for liquids with a flash point between  $-18^{\circ}\text{C}$  ( $0^{\circ}\text{F}$ ) and  $70^{\circ}\text{C}$  ( $126^{\circ}\text{F}$ ) and the Pensky-Martens Method for liquids having flash points between  $-7^{\circ}\text{C}$  ( $19^{\circ}\text{F}$ ) and  $371^{\circ}\text{C}$  ( $700^{\circ}\text{F}$ ).

## 2. AUSTRIA (ON)

**OSTERREICHISCHES NORMUNGSINSTITUT, HEINESTRASSE 38, POSTFACH 130, A-1021 WIEN, AUSTRIA.**

*NR 5740*—DK 665.7:620.1 Testing of Products of the Mineral Oil Industry, Mineral Oils, and Similar Products in General.

*C 1121*—Testing of Mineral Oil Products; Flash Point According to the Abel-Pensky Method.

*C 1122*—Testing of Mineral Oil Products; Flash Point by Pensky-Martens Closed Tester.

*C 1123*—Testing of Mineral Oil Products; Flash Point According to Marcusson Open Cup Method.

## 3. BANGLADESH (BDSI)

**BANGLADESH STANDARDS AND TESTING INSTITUTION, 116/A TEJGAON INDUSTRIAL AREA, DHAKA-8, BANGLADESH.**

BDSI has issued no flash point standards, but various petroleum products standards include flash point as one of their characteristics.

#### 4. BELGIUM (IBN)

**INSTITUT BELGE DE NORMALISATION,  
AVENUE DE LA BRABANCONNE, 29, B-1040  
BRUXELLES, BELGIUM.**

*NBN T-52-075*—Determination of Flash Point of Petroleum Products by Means of the Abel-Pensky Closed Cup.

*NBN T-52-101*—Petroleum Products—Flash Point and Fire Point by Cleveland Open Cup.

*NBNT-52-110*—Petroleum Products—Flash Point by Means of the Pensky-Martens Closed Cup Apparatus.

#### 5. CANADA (SCC)

**Standards Council of Canada, International  
Standardization Branch, 2000 Argentina Road Suite  
2-401, Mississauga, Ontario, L5N 1V8, Canada.**

*1-GP-71 (Method 3.1)*—Flash Point of Pigmented Material by the Pensky-Martens Closed Cup Tester.

Part A of this Method describes testing procedures for flash points above 10°C (50°F), while Part B describes those for flash points below 10°C (50°F).

#### 6. PEOPLES REPUBLIC OF CHINA (CSBS)

**China State Bureau of Standards, P.O. Box 820,  
Beijing, China.**

*GB 261*—Petroleum Products—Determination of Flash Point-Closed Cup Method.

*GB 267*—Determination of Flash and Ignition Point of Petroleum Products (Open Cup Method).

*GB 3536*—Petroleum Products—Determination of Flash and Fire Points-Cleveland Open Cup Method.

#### 7. REPUBLIC OF CHINA (CNS)

**National Bureau of Standards, Ministry of  
Economic Affairs, 5th Floor, Hsin Kwang Life  
Insurance Building, Bldg. 61-1 Sung-Chiang Rd.,  
Taipei, Taiwan, Republic of China.**

*3775 (K 6377)*—Determination of Flash and Fire Points for Petroleum Products with Cleveland Open Cup.

*7180 (Z 6038)*—Test Methods for Flammability of Aerosol Products.

#### 8. COLUMBIA (ICONTEC)

**Instituto Colombiano de Normas Técnicas,  
Carrera 37 No. 52-95, P.O. Box 14237, Bogota,  
Colombia.**

*ICONTEC 1692*—Transportation and Storage—Dangerous Goods. Classification and Labeling.

This standard defines flammable liquids by the open cup flash point method but classifies these liquids by methods described in International Maritime Dangerous Goods Code,

Inter-Governmental Maritime Organization (closed cup methods).

*ICONTEC 559*—Petroleum and Its Derivatives—Determination of Flash and Fire Point (Cleveland Open Cup Method).

#### 9. CZECHOSLOVAKIA (CSN)

**Urad pro normalizaci a meren 19, vaclavske  
namesti, 113 47 PRAHA 1, Czechoslovakia.**

*CSN 67 3015*—Determination of Flash Points by the Abel-Pensky Closed Cup.

#### 10. DENMARK (DS)

**Dantest, National Institute for Testing &  
Verification, Amager Boulevard 1/5, Postboks  
1915—DK 2300, Copenhagen, Denmark.**

Denmark uses either ASTM standards or ISO standards. In Denmark, ISO standards are published as ISO/DS standards and, if necessary, translated to Danish.

#### 11. ECUADOR (INEN)

**Instituto Ecuatoriano de Normolizacion, Calle  
Bagerizo Moreno No. 454, entre 6 de Diciembre Y  
Almagro, Casilla No. 3999, Quito, Ecuador.**

*INEN 1047*—Petroleum Products—Flash Point by Closed Cup-Tag Method.

#### 12. EGYPT, ARAB REPUBLIC OF

**Organization for Standardization and Quality  
Control, 2 Latin America St., Garden City, Cairo,  
Egypt.**

*ES 159*—Standard Method for Determination of Flash Point (Open) and Fire Point of Petroleum Products by Cleveland Cup.

*ES 177*—Standard Method for Determination of Flash Point (Closed) for Petroleum Products by Pensky-Martens Apparatus.

#### 13. FRANCE (AFNOR/NF)

**Association Francaise de Normalisation, Tour  
Europe. Cedex 7, 92080, Paris La Defense, France.**

*NFM 07-011*—Combustible Liquids—Flash Point by Means of the Abel Closed Cup Apparatus.

*NF M 07-019*—Combustible Liquids—Determination of Flash Points Above 50°C by Means of the Pensky-Martens Closed Cup Apparatus.

*NF M 07-036*—Combustible Liquids—Flash Point by the Abel-Pensky Closed Cup Method.

*NFT 30-051*—Paint and Varnish—Determination of Categories of Danger by Flash Point-Closed Cup Method (European Standard EN 53).

*NFT 60-103*—Petroleum Products—Flash Point of Lubricants and Combustible Oils by the Luchoire Closed Cup Apparatus.

*NFT 60-118*—Petroleum Products—Flash and Fire Points in the Oil and Grease Industries by the Cleveland Open Cup.

*NFT 66-009*—Flash Point of Bitumens by the Abel Closed Cup Apparatus.

## 14. GERMANY (DIN)

**DIN Deutsches Institut Fur Normung e.V., Postfach 1107, D-1000 Berlin 30, Germany.**

*DIN 51 755*—(For determining flash point in testing of mineral oils and other combustible liquids)—Flash Point by the Closed Tester According to Abel-Pensky Method.

*DIN 51 755, Part 2*—(For testing of mineral oils and other combustible liquids)—Flash Point by the Closed Tester According to Abel-Pensky Method.

This Method is used to determine flash point below +5°C to approximately -30°C.

*DIN 51 758*—(For determining flash point in testing of mineral oils and other combustible liquids)—Flash Point by the Closed Tester According to the Pensky-Martens Method.

*DIN 53 213, Part 1*—(For determining flash point in testing of paints, varnishes and similar products containing solvents)—Flash Point Test Using Closed Cup.

*DIN 55679*—(For determining flash point in paints, varnishes and related products)—Rapid Equilibrium Method (ISO 3679, edition 1983 modified).

*DIN 55680*—(For paints, varnishes and related products)—Flash/No Flash Test by Rapid Equilibrium Method (ISO 3680 modified).

*DIN ISO 1516*—(For paints, varnishes, petroleum and related products)—Flash/No Flash Test by Closed Cup Equilibrium Method (Identical with ISO 1516, edition 1981).

*DIN ISO 2592*—(For petroleum products)—Determination of Flash and Fire Points by Cleveland Open Cup Method.

*DIN 51 794*—(For testing of mineral oil hydrocarbons)—Determination of Ignition Temperature.

*DIN 55 990, Part 6*—(For testing of paints, varnishes and similar coating materials)—Powder Coatings by Calculation of Lower Ignition Limit.

## 15. HUNGARY (HU/MSZH)

**Hungarian Office for Standardization, Magyar Szabványügyi Hivatal, Postafiók 24, 1450 Budapest 9, Hungary.**

*KGST 1495*—Determination of Flash Point by Pensky-Martens Closed Cup Method.

*KGST 1496*—Determination of Flash Point by Marcusson Open Cup Method.

## 16. INDIA (ISI)

**Indian Standards Institution, Manak Bhavan, 9 Bahadur Shah Zafar Marg, New Delhi 110002, India.**

*IS-1448, Part 1, P:20*—Flash Point by Abel Tester.

*P:21*—Flash Point by Pensky-Martens Tester.

## 17. INDONESIA (DSN)

**Dewan Standardisasi, Nasional-DSN, (Standardization Council of Indonesia, Gedung PDIN-LIPI, Jalan Gatot Subroto, P.O. Box 3123, Jakarta 12190, Indonesia.**

The Directorate General of Oil and Gas of the Department of Mines and Energy has issued specifications for petroleum fuels for the domestic market, specifying the following flash point methods.

*IP-170 (Jet Fuel)*—Flash Point by the Abel Apparatus.

*IP-170 (Kerosene)*—Flash Point by the Abel Apparatus.

*ASTM D 93 (Diesel Fuel)*—Flash Point by Pensky-Martens Closed Tester.

*ASTM D 93 (Fuel Oil)*—Flash Point by the Pensky-Martens Closed Tester.

## 18. IRAN (ISIRI)

**Institute of Standards and Industrial Research of Iran, Ministry of Industries, P.O. Box 11365-7594, Tehran, Iran.**

*ISIRI*—Measurement of Flash Point of Lubricating Oil—Apparatus Methods are Described for Flash Point Above 80°C.

## 19. IRAQ (COSQC)

**Central Organization for Standardization and Quality Control, Planning Board, P.O. Box 13032, Aljadiria, Baghdad, Iraq.**

*COSQC 86*—Determination of Flash Point by Pensky-Martens Open Cup.

*COSQC 134*—Determination of Flash and Fire Points by Cleveland Open Cup.

## 20. ISRAEL (SII)

**Standards Institution of Israel, 42 University Street, Tel Aviv, 69977, Israel.**

*S11-107 (Diesel Oil)*—Specifies Flash Point Standard ASTM D 93/IP 34. Flash Point by Pensky-Martens Closed Tester.

## 132 FLASH POINT STANDARDS AND THEIR USE

*S11-100 (Kerosine)*—Specifies Flash Point Standards IP33/59. Flash Point by the Abel Apparatus.

### 21. ITALY (UNI)

**Ente Nazionale Italiano Di Unificazione, Piazza Armando Diaz, 2, 20123 Milano, Italy.**

*UNI EN 57*—(Petroleum Products)—Determination of Flash Point by Abel-Pensky Closed Tester.

*NOM 18*—Determination of Flash Point by the Pensky-Martens Closed-Cup Apparatus.

*NOM 83*—Determination of Flash and Fire Point Using the Cleveland Open-Cup Apparatus.

NOTE—UNI EN—European standards (European Committee for Standardization) adopted as national standard.

NOM—Italian standards for inspection of mineral oils and derivatives. These are issued by the laboratory for Tests on Oils and Fats.

### 22. JAPAN (JISC/JIS)

**Japanese Industrial Standards Committee, c/o Standards Department, Agency of Industrial Science and Technology, Ministry of International Trade and Industry, 1-3-1 Kasumigaseki, Chiyoda-Ku, Tokyo 100, Japan.**

*JIS K2265*—Testing Methods for Flash Point of Crude Oil and Petroleum Products: Pensky-Martens Closed Cup [less than] 50°C (120°F)—Crude Oil—Turbine Oil—Prevent rust oil. Cleveland Open Cup [less than] 80°C (174°F)—Asphalt—Wax—Machine Oil.

*JIS K2274*—Test Method for Flash Point by Cleveland Open Cup Apparatus.

*JIS K2421*—Test Method—Benzene Family.

*JIS B7410*—Crude Oil—Petroleum Testing—Flash Point.

*JIS K8004*—Reagent—General Test Method—Flash Point.

### 23. JORDAN

**Directorate of Standards, Ministry of Industry and Trade, P.O. Box 2019, Amman, Jordan.**

73—Determination of Flash and Fire Points by Cleveland Open Cup.

172—(Petroleum Products)—Determination of Flash Point by Pensky-Martens Closed Cup Method.

### 24. KUWAIT

**Standards and Metrology Department, Ministry of Commerce & Industry, P.O. Box No. 2944, Kuwait.**

ASTM and IP Standards for Flash Point are normally followed in Kuwait.

### 25. MEXICO (DGN/NOM)

**Comencio y Fomento Industrial, Direccion General de Normas, Calle Puente de, Tecamachalco No 6, Lomas de Tecamachalco, Seccion Fuentes, Naucalpan de Juarez, 53 950 Mexico City, Mexico.**

*NOM L 075*—Products Derived from Petroleum—Diesel Fuel—Determination of Flash Point by the Pensky-Martens Closed Cup Method.

### 26. THE NETHERLANDS (NNI)

**Nederlands Normalisatie-Instituut, Kalfjeslaan 2, P.O. Box 5059, 2600 GB Delft, Netherlands.**

*NEN 3204*—Determination of Flash Points up to 65°C by Abel-Pensky Apparatus.

*NEN ISO-2719*—Determination of Flash Points by the Pensky Martens Closed Tester.

### 27. NEW ZEALAND (SANZ)

**Standards Association of New Zealand, Private Bag, Wellington, New Zealand.**

*BS 2839*—Determination of Flash Point of Petroleum Products by Pensky-Martens Method, Closed.

### 28. SAUDI ARABIA (SASO)

**Saudi Arabian Standards Organization, P.O. Box 3437, Riyadh, Saudi Arabia 11471.**

*SSA*—Determination of the Flash Point of Petroleum Products by the Abel Apparatus.

*SSA 25*—Determination of Flash and Fire Point for Petroleum Products by Cleveland Open Cup Apparatus.

*SSA 318*—Industrial Safety and Health Regulations.

- Part 4—Hazardous Materials—Flammable and Combustible Liquids.
- Part 20—Petroleum Industry.

### 29. SINGAPORE (SISIR)

**Singapore Institute of Standards and Industrial Research, Maxwell Road, P.O. Box 2611, Singapore 9046.**

*SS 286 (Part 1)*—Specification for Caution Labelling of Hazardous Substances. Classification and Class Labels for Hazardous Substances.

This standard specifies the following flash point methods:  
*BS 2000 (Part 170)*—Abel Closed Cup Method for Flash Point of -18°C to 70°C.

*ASTM D 93*—Test Methods for Flash Point by Pensky-Martens Closed Tester.

**30. REPUBLIC OF SOUTH AFRICA (SABS)**

**South African Bureau of Standards, Private Bag X 191, Pretoria, Republic of South Africa.**

*SABS 890*—Flammability of Aerosols (Flame Projection Test).

*SABS 894*—Pesticides: Flash Point of Emulsifiable Concentrates Flashing Below 79°C (174°F) Using the Tag Closed Tester.

**31. SWEDEN (SIS)**

**Standardiserings kommissionen i Sverige, Tegnergatan 11, Swedish Standard Institute, P.O. Box 3295, S-10366 Stockholm, Sweden.**

*SIS 021810*—Flash Point by the Abel-Pensky Tester.

*SIS 021811*—Flash Point by the Abel-Pensky Tester with Stirrer.

*SIS 021812*—Flash Point by the Pensky-Martens Tester.

**32. SWITZERLAND (SNV)**

**Schweizer Normen-Verlinigung, Swiss Association for Standardization, Kirchenweg 4 CH-8032, Postfach 8032, Zurich, Switzerland.**

*DIN 51-755*—Flash Point by the Abel-Pensky Closed Tester.

*DIN 51 758*—Flash Point by the Pensky-Martens Closed Tester.

*ISO 2719*—Flash Point by the Pensky-Martens Closed Tester.

*ASTM D 93*—Flash Point by the Pensky-Martens Closed Tester.

*DIN ISO 2592*—Flash and Fire Point by Cleveland Open Cup Method.

*ASTM D 92*—Flash and Fire Point by Cleveland Open Cup.

*ISO 3679*—Paints, varnishes, petroleum and related products—Determination of Flash Point by Rapid Equilibrium Method.

*ISO 3680*—Paints, varnishes, petroleum and related products—Flash/No Flash Test Rapid Equilibrium Method.

**33. UNITED KINGDOM**

**33.1 British Standards Institution (BSI)—2 Park St., London W1A 2BS, England.**

The following test methods are given with their ISO, IP, CEN, or ASTM Equivalents:

*BS 244 (ISO 412)*—Turpentine for Paints, Type 1 Gum Spirits of Turpentine.

*BS 290*—Turpentine for Paints, Type 2 Wood Turpentine and Type 3 Sulphate Turpentine.

*BS 2000, Part 33 (IP 33)*—Flash Point by the Abel Apparatus (Statutory Method: Petroleum (Consolidation) Act 1928).

*BS 2000, Part 34 (ISO 2719, IP 34, ASTM D 93)*—Flash Point by Pensky-Martens Closed Tester.

*BS 2000, Part 35 (IP 35)*—Flash Point (Open) and Fire Point of Petroleum Products by the Pensky-Martens Apparatus.

*BS 2000, Part 113 (IP 113)*—Flash Point (Closed) of Cutback Bitumen.

*BS 2000, Part 170 (IP 170)*—Flash Point by the Abel Apparatus (Non-Statutory Method).

*BS 3900, Part A8 (EN 53, ISO 1516, IP 304)*—Determination of the Danger Classification by Flash Point Closed Cup Method.

*BS 3900, Part A9 (ISO 1523, IP 304)*—Determination of Flash Point by the Closed Cup Method.

*BS 3900, Part A11 (ASTM D 4206)*—Small Scale Test for Combustibility.

*BS 3900, Part A13 (ISO 3680, IP 303, ASTM D 3828)*—Rapid Test for Determination of Danger Classification by Flash Point.

This is an alternative to BS 3900, Part A8, using apparatus that enables a more rapid procedure and small test portion to be used.

*BS 3900, Part A14 (ISO 3679, IP 303, ASTM D 3828)*—Rapid Test for Determination of Flash Point.

This is an alternative to BS 3900, Part A9, using apparatus that enables a more rapid procedure and a smaller test portion to be used.

*BS 4689 (ISO 2592, IP 36, ASTM D 92)*—Method for Determination of Flash and Fire Points of Petroleum Products by the Cleveland Open Cup Method.

**33.2 THE INSTITUTE OF PETROLEUM (IP)—61 NEW CAVENDISH ST., LONDON W1M 8AR, ENGLAND.**

One of the important international standards organizations for flash point testing is the Institute of Petroleum. Most of their standards are joint standards with those of ASTM Committee D 2 on Petroleum and Lubricants. These standards can be obtained from either ASTM or IP.

*IP 33*—Flash Point by the Abel Apparatus Petroleum (Consolidation) Act 1928 Method.

*IP 34 (ASTM D 93)*—Flash Point by Pensky-Martens Closed Tester.

*IP 35*—Flash Point (open) and Fire Point by Means of the Pensky-Martens Apparatus.

*IP 36 (ASTM D 92)*—Flash and Fire Points by Cleveland Open Cup.

*IP 113*—Flash Point (closed) of Cutback Bitumen.

*IP 170*—Flash Point by the Abel Apparatus.

*IP 303 (ASTM D 3828)*—Rapid Tests for Flash Point.

*IP 304*—Flash Test Using the Cup of Any Standards Closed Cup Apparatus.

*IP 349*—Code of Practice for Calibrating and Checking Process Analyzers—Flash Point Analyzers.

Distillation and viscosity standards are similar to ASTM standards. These are listed under the auxiliary standards below.

*IP 27 (ASTM D 402)*—Distillation of Cutback Asphaltic (Bituminous) Products.

*IP 71 (ASTM D 445)*—Viscosity of Transparent and Opaque Liquids (Kinematic and Dynamic Viscosity).



## 134 FLASH POINT STANDARDS AND THEIR USE

*IP 72*—Viscosity-Cutback Bitumen and Road Oil.

*IP 123 (ASTM 86)*—Distillation of Petroleum Products.

*IP 195*—Distillation Range of Volatile Organic Liquids.

*IP 212*—Viscosity-Bitumen Road Emulsion.

*IP 319 (ASTM D 2170)*—Kinematic Viscosity of Asphalts (Bitumen).

### 34. USSR (GOST)

**State Committee of the USSR Council of Ministers for Standardization, M-49 Leninsky Prospekt, 9, Moscow 117049, USSR.**

The following USSR standards are listed in the *Transport of Dangerous Goods—Recommendations of the Committee of Experts on the Transport of Dangerous Goods, United Nations. GOST 4333*—Oils and Heavy Oils/Oil Products—Methods for Determining the Temperatures of Flash Point and Flammability in an Open Cup (Crucible).

*GOST 6356*—Oil Products—Organic Chemical Products Method for Determining the Flash Point Temperature in a Closed Cup (Crucible).

### 35. VENEZUELA (COVENIN)

**Ministerio de Fomento, Commission Venezolana de Normas Industriales, Apdo 51116, Cod, Postal 1050A, Caracas, Venezuela.**

Venezuela's Flash Point Standards are related to ASTM Flash Point Standards as shown below:

*Covenin 372 (ASTM D 92)*—Determination of Flash and Fire Point (Method Cleveland Open Cup).

*Covenin 421 (ASTM D 56)*—Determination of the Flash Point of Flammable Liquids, by the Tag Closed Cup Method.

*Covenin 425 (ASTM D 93)*—Determination of Flash Point, Method Pensky-Martens Closed Cup.

*Covenin 896 (ASTM D 56)*—Determination of Flash Point by the Tag Closed Cup Method.

### 36. ZIMBABWE (CT)

**Standards Association of Central Africa, 17 Coventry Road, P.O. Box 2259, Harare, Zimbabwe.**

*C 22*—The Storage, Transfer and Use of Small Quantities of Flammable Liquids.

## **Part IV: International Standards and Regulations**

# International Flash Point and Related Standards

## INTRODUCTION

### ISO

The International Organization for Standardization (ISO) is the specialized international agency for standardization, which at present comprises the national standards bodies of 90 countries (see Appendix C). The objective of ISO is to promote the development of standardization and related activities in the world with a view to facilitating international exchange of goods and services, and to developing cooperation in the sphere of intellectual, scientific, technological and economic activity. The scope of ISO covers standardization in all fields except electrical and electronic engineering standards, which are the responsibility of the International Electrotechnical Commission (IEC).

#### Members

A *member body* of ISO is the national body "most representative of standardization in its country." Only one such body for each country is accepted for membership in ISO. Member bodies are entitled to participate and exercise full voting rights on any technical committee of ISO. More than 70% of the ISO member bodies are governmental institutions or organizations incorporated by public law. The remainder have close links with the public administration in their own countries.

A *correspondent member* is normally an organization in a developing country that does not yet have its own national standards body. Correspondent members do not take an active part in the technical work, but are entitled to be kept fully informed about the work of interest to them.

#### Technical Work

The technical work of ISO is carried out through technical committees (TC). The technical committees may, in turn, establish subcommittees (SC) and working groups (WG) to cover different aspects of work. More than 20 000 experts from all parts of the world participate each year in the ISO technical work which, to date, has resulted in the publication of 6401 ISO standards.

Each committee is concerned with a specific industry or interest such as paint or petroleum. Among these committees, TC-28 for Petroleum Products and Lubricants and TC35 for Paints and Varnishes are involved in flash point standard method development.

The office and mailing addresses for ISO areas are as follows:

Office address—ISO, 1 rue de Varembé, CH-1211 Geneve 20, Switzerland.

Mailing address—ISO, Case Postale 56, CH-1211 Geneve 20, Switzerland.

### European Committee for Standardization (CEN)

CEN promotes European Standardization in non-electrotechnical fields. Its steering committee issues European Standards (ENs) up to EN 49 999. The countries of Western Europe have been harmonizing their national standards one way or another for a number of years. The purpose behind this harmonization work is to promote the development of trade between 16 countries, each of which has its own language, standards, customs, and procedures. This is a formidable objective, requiring agreement on standards and mutual recognition of approval schemes on a regional basis.

Twenty-five years ago, the standardization institutions of Western Europe formed the European Committee for Standardization (CEN), which prevented the drifting apart of standards of the European Economic Community (EEC). The EEC is often referred to as the Common Market and the European Free Trade Area (EFTA). ENs are generally agreed to by both EEC and EFTA countries on the basis of a rather complicated voting procedure.

Once ENs are approved they are printed as national standards in the respective countries. ENs have no separate existence of their own; they are published by national standards bodies of the member countries.

Correspondence to CEN should be directed to Secretariat, CEN Secretary General, 2 Rue Brederode, B-1000 Brussels, Belgium.

Just as in the U.S., there are methods other than flash point used to define the flammability of liquids for use in international regulations of hazardous substances. One of these is ISO Method 2431, *Paints and Varnishes—Determination of Flow Time by Use of Flow Cups*. This method is excerpted with permission from ISO/ANSI in Section 9 below.

Viscous substances are classed in Packing Groups for transportation by flash point at respective flow times. For more information, see Chapter 15 on Regulations of International Regulatory Agencies.

The standards concerning flash point and related procedures are listed below. These standard excerpts are reprinted with permission from ISO through the American National Standards Institute (ANSI), 1430 Broadway, New York, NY 10018.

## 1. ISO 412-1976(E)—GUM SPIRIT OF TURPENTINE AND WOOD TURPENTINES FOR PAINTS AND VARNISHES.

### Scope and Field of Application

This International Standard specifies the requirements and corresponding test methods for gum spirit of turpentine and wood turpentines for use in paints, varnishes and related products.

### References (Flash Point)

ISO 1516, *Paints, Varnishes, Petroleum, and Related Products—Flash/No Flash Test—Closed Cup Equilibrium Method.*

ISO 3680, *Paints, Varnishes, Petroleum and Related Products—Determination of Flash/No Flash—Rapid Equilibrium Methods.*

### Definitions

**Gum Spirit of Turpentine**—The product obtained from oleoresins from pine trees by distillation at a temperature below 180°C (356°F) or by any other method of fractionation which does not alter the terpenic constituents of the oleoresins. It is accepted good practice to tap only certain varieties of living pines for oleoresins for the manufacture of gum spirit of turpentine. Gum spirit of turpentine is composed of a mixture of terpenes (with a small proportion of sesquiterpenes) and oxygenated products. It may contain small quantities of rosin or rosin oil, arising from the method of production, as well as products of oxidation arising from aging, provided that the product complies with the requirements given in the standard, particularly with those of relative density, evaporation residue and acid value. No other impurities can be tolerated.

**Wood Turpentines**—The volatile oils consisting primarily of a number of terpene hydrocarbons of the general formula  $C_{10}H_{16}$ , obtained from pine wood. Three kinds of wood turpentine are now recognized:

- *Steam-distilled wood turpentine*—the wood turpentine obtained from the oleoresin within the wood of pine stumps or cuttings, either by direct steaming of the mechanically disintegrated wood or by steaming the oleoresin obtained by solvent extraction.
- *Sulphate wood turpentine*—The wood turpentine recovered during the conversion of wood to paper pulp by the sulphate process.
- *Destructively distilled wood turpentine*—The wood turpentine obtained by fractionation of certain oils recovered by condensing the vapors formed during the destructive distillation of pine wood.

Crude destructively distilled wood turpentines have generally an almost black color and contain acids, phenols and tarry materials. They should undergo a refining distillation before use. They can be immediately distinguished from the other turpentines by their odor and color.

All turpentines have a minimum flash point of 32°C (89.6°F) in accordance with ISO test methods 1516 and 3680.

## 2. ISO 1516-1981(E)—PAINTS, VARNISHES, PETROLEUM AND RELATED PRODUCTS—FLASH/NO FLASH TEST—CLOSED CUP EQUILIBRIUM METHOD.

NOTE—This method is similar to ASTM D 3934—*Method for Flash/No Flash Test—Equilibrium by a Closed-Cup Apparatus.*

### Introduction

This international standard sets out one of two methods for carrying out the flash/no flash test for paints, varnishes, petroleum and related products, and it should be read in conjunction with ISO 3680 when selecting a method (see Section 7 of this chapter).

This method of test does not determine the flash point of the product under test, but merely its behavior at the selected equilibrium temperature as may be required to comply with laws or regulations relating to the storage, transport and use of flammable products. For this purpose it is unnecessary to determine the exact flash point, but it is necessary to determine whether or not flashing occurs at a single given temperature. By the procedure specified, differences between test apparatus of various standard designs are minimized by ensuring that the test is carried out only when the product under test and the air/vapor mixture above it in the test vessel are exactly in temperature equilibrium.

NOTE—The determination of the exact flash point using the same equipment is given in ISO 1523 (see Section 3 below).

### Scope and Field of Application

This international standard specifies a method to determine if a flammable material such as a paint, varnish, paint binder, solvent, petroleum or a related product, when maintained at a selected equilibrium temperature and under the conditions of the test, gives off sufficient flammable vapor at this temperature to cause ignition on application of an external source of flame applied in a standard manner.

The method is suitable for use over the temperature range of 5 to 65°C (41 to 149°F), although some of the apparatus listed in Annex A below cannot cover all of this range using the thermometer supplied with the apparatus. The procedure also makes allowance for deviations from standard atmospheric pressure.

### References (Flash point)

ISO 1523, *Paints, Varnishes, Petroleum and Related Products—Determination of Flash Point—Closed Cup Equilibrium Method.*

ISO 3680, *Paints, Varnishes, Petroleum and Related Products—Flash/No Flash Test—Rapid Equilibrium Method.*

### Principle

The test portion is heated in a suitably designed closed cup in a suitable water-bath. The ignition trial is carried out after the test portion has been maintained under equilibrium conditions for at least 10 min at the selected equi-

librium temperature. This procedure ensures that the air/vapor space above the test portion has attained the saturation concentration of flammable vapor before the ignition trial is performed. The test report records whether the test portion flashed or did not flash.

Annex A  
Suitable Closed Cups Specified In Standards

The cups listed below of closed-cup apparatus described in standards are known to satisfy the necessary requirements of this method for carrying out the flash/no flash test. The method requires immersion of the cup in a water-bath and if a suitable bath is not included in the standard apparatus one must be provided.

Abel cup	British Standard	BS 3442 (and IP 33 and IP 170)
Abel cup	French Standard	NF T 66-009
Abel cup	French Standard	NF M 07-011
Abel-Pensky cup	French Standard	NF M 07-036
Abel-Pensky cup	German Standard	DIN 51 755
Abel-Pensky cup (+ stirrer)	Swedish Standard	SIS 02 18 11
Abel-Pensky cup (modified according to Bleisch)	German Standard	DIN 53 213, Teil 1
Pensky-Martens cup	International Standard	ISO 2719
Pensky-Martens cup	British Standard	BS 2839 (and IP 34)
Pensky-Martens cup	French Standard	NF M 07-019
Pensky-Martens cup	German Standard	DIN 51 758
Pensky-Martens cup	Netherlands Standard	NEN-ISO 2719
Pensky-Martens cup	Swedish Standard	SIS 02 18 12
Pensky-Martens cup	USA Standard	Z 11.7 (and ASTM D 93)
Tag cup	USA Standard	Z 11.24 (and ASTM D 56)

### 3. ISO 1523-1983(E)—PAINTS, VARNISHES, PETROLEUM AND RELATED PRODUCTS—DETERMINATION OF FLASH POINT—CLOSED CUP EQUILIBRIUM METHOD.

NOTE—This method is similar to ASTM D 3491—*Test Method for Flash Point by the Equilibrium Method with a Closed-Cup Apparatus*.

#### Introduction

This international standard describes one of two methods for the determination of the flash point of paints, varnishes, petroleum and related products and it should be read in conjunction with ISO 3679 when selecting a method (see Section 6 below).

By the procedure specified in this international standard, differences between test apparatus of various standard designs are minimized by ensuring that the test is carried out only when the product under test and the air/vapor mixture above it in the test vessel are approximately in temperature equilibrium.

Nevertheless the interpretation of results obtained from solvent mixtures containing halogenated hydrocarbons should be considered with caution as these mixtures can give anomalous results.

NOTE—The flash/no flash test using the same equipment under equilibrium conditions is given in ISO 1516 (see Section 2 above).

#### Scope and Field of Application

This international standard specifies a method for determining the flash point of a paint, varnish, paint binder, solvent, petroleum or a related product and makes allowance for deviations from standard atmospheric pressure.

The method is suitable for use over the temperature range 5 to 110°C (41 to 230°F), although some of the apparatus listed in Annex A cannot cover all of this range using the thermometer supplied with the apparatus.

#### References

ISO 1516, *Paints, Varnishes, Petroleum and Related Products—Flash/No Flash Test—Closed Cup Equilibrium Method*.

ISO 3679, *Paints, Varnishes, Petroleum and Related Products—Determination of Flash Point—Rapid Equilibrium Method*.

#### Definition

*Flash Point (closed cup)*—Minimum temperature to which a product, confined in a closed cup, must be heated for the vapors emitted to ignite momentarily in the presence of a flame, when operating under standardized conditions.

NOTE—In this international standard, the flash point is corrected to an atmospheric pressure of 101.3 kPa (1013 mbar).

#### Principle

The test portion is heated in a suitably designed closed cup by immersing it to the required level in a suitable bath. The temperature of the bath is slowly raised at such a rate that the difference in temperature between the liquid in the bath and the test portion in the cup never exceeds 2°C (3.5°F) and the heating procedure ensures that the temperature of the test portion does not rise more quickly than about 0.5°C (1°F) in 1.5 min.

Annex A  
Suitable Closed Cups Specified In National Standards

The cups listed below of closed-cup apparatus described in standards are known to satisfy the necessary requirements of this method of test for the determination of flash point. The method requires immersion of the cup in a bath and if a suitable bath is not included in the standard apparatus one must be provided.

Abel cup	British Standard	BS 3442 (and IP 33 and IP 170)
Abel cup	French Standard	NF T 66-009
Abel cup	French Standard	NF M 07-011
Abel-Pensky cup	Czechoslovakian Standard	CSN 67 3015

## Annex A—Continued

Abel-Pensky cup	French Standard	NF M 07 036
Abel-Pensky cup	German Standard	DIN 51 755
Abel-Pensky cup (+ Stirrer)	Swedish Standard	SIS 02 18 11
Pensky-Martens cup (modified according to Bleisch)	German Standard	DIN 53 213 Teil 1
Pensky-Martens cup	International Standard	ISO 2719
Pensky-Martens cup	British Standard	BS 2839 (and IP 34)
Pensky-Martens cup	French Standard	NF M 07 019
Pensky-Martens cup	German Standard	DIN 51 758
Pensky-Martens cup	Netherlands Standard	NEN-ISO 2719
Pensky-Martens cup	Swedish Standard	SIS 02 18 12
Pensky-Martens cup	USA Standard	Z 11.7 (and ASTM D 93)
Tag cup	USA Standard	Z 11.24 (and ASTM D 56)

#### 4. ISO 2592-1983(E)—PETROLEUM PRODUCTS—DETERMINATION OF FLASH AND FIRE POINTS—CLEVELAND OPEN CUP METHOD.

NOTE—This method is similar to ASTM D 92—*Test Method for Flash and Fire Points by Cleveland Open Cup* (see Chapter 2 for full reprint).

##### Scope and Field of Application

This international standard specifies a method, using the Cleveland open cup apparatus, of determining the flash and fire points of petroleum products. It is suitable for all petroleum products except for fuel oils and products having an open cup flash point (determined by this method) below 79°C (174°F).

NOTE—Attention is drawn to the alternative method specified in ISO 2719, *Petroleum Products—Determination of Flash Point—Pensky-Martens Closed Cup Method* (see Section 5 below); this is recommended for determining the flash points of fuel oils and should be used when it is desired to determine the possible presence of small but significant concentrations of lower flash point substances which may escape detection when using ISO 2592.

##### Principle

The test cup is filled to a specified level with the test portion. The temperature of the test portion is increased rapidly at first and then at a slow, constant rate as the flash point is approached. At specified temperature intervals a small test flame is passed across the cup. The lowest temperature at which application of the test flame causes the vapor above the surface of the liquid to ignite is taken as

the flash point. To determine the fire point, the test is continued until the application of the test flame causes the oil to ignite and burn for at least 5 s.

#### 5. ISO 2719-1988 (2nd edition)—PETROLEUM PRODUCTS—DETERMINATION OF FLASH POINT—PENSKY-MARTENS CLOSED CUP METHOD.

NOTE—This method is similar to ASTM D 93—*Test Methods for Flash Point by Pensky-Martens Closed Tester* (see Chapter 2 for full reprint).

##### Scope

This international standard specifies methods, using the Pensky-Martens closed cup apparatus, of determining the flash point of combustible liquids, liquids with suspended solids, lubricating oils, liquids that tend to form a surface film under test conditions, and other liquids.

Open cup flash and fire points of petroleum products may be determined by the use of ISO 2592 (see Section 4 above). Flash points of paints and varnishes and drying oils may be determined by the use of ISO 1523 (see Section 3 above).

NOTE—The method described in this international standard may be employed for the detection of contamination of lubricating oils by minor amounts of volatile material, which also often occurs in heat transfer oils due to partial cracking. However, the lowest temperature at which such a liquid is capable of producing an ignitable atmosphere may be lower than that found by this method.

##### Definition

*Flash Point*—The lowest temperature, corrected to a barometric pressure of 101.3 kPa (1013 mbar), at which application of a test flame causes the vapor of a test portion to ignite under specified conditions of test.

The sample is deemed to have flashed when a large flame appears and instantaneously propagates itself over the surface of the sample. Occasionally, particularly near the actual flash point, the application of the test flame will cause a blue halo or an enlarged flame; this is not a flash and should be ignored.

##### Principle

The test portion is heated at a slow, constant rate with continual stirring in a cup closed by a lid. A small flame is directed through an opening (kept closed at other times) into the cup at regular temperature intervals with simultaneous interruption of stirring. The flash point is the lowest temperature at which application of the test flame causes the vapor above the test portion to ignite.

## 6. ISO 3679-1983(E)—PAINTS, VARNISHES, PETROLEUM AND RELATED PRODUCTS—DETERMINATION OF FLASH POINT—RAPID EQUILIBRIUM METHOD.

NOTE—This Method is similar to ASTM D 3278—*Test Method for Flash Point of Liquids by Setaflash-Closed-Cup Apparatus* and D 3828—*Test Method for Flash Point by Setaflash Closed Tester* (see full reprints in chapter 2).

### Introduction

This international standard describes one of two methods for the determination of the flash point of paints, varnishes, petroleum and related products and it should be read in conjunction with ISO 1523 when selecting a method (see Section 3 above). In ISO 1523, a similar determination is specified, using cups described in various national standards.

In both methods, the test is carried out only when the product under test and the air/vapour mixture above it in the test vessel are approximately in temperature equilibrium.

The apparatus specified in this international standard enables a similar result to be determined using a more rapid procedure and with a smaller test portion (2 mL) of material than that given in ISO 1523. In addition, the apparatus can be made portable to the extent of being suitable for on-site testing as well as for normal use in laboratories. Collaborative work<sup>1</sup> has shown that results obtained by these procedures are comparable.

Nevertheless the interpretation of results obtained from solvent mixtures containing halogenated hydrocarbons should be considered with caution as these mixtures can give anomalous results<sup>2</sup>.

NOTE—The flash/no flash test using the same equipment under equilibrium conditions is given in ISO 3680 (see Section 7 below).

### SCOPE AND FIELD OF APPLICATION

This international standard specifies a method for determining the flash point of a paint, varnish, paint binder, solvent, petroleum or a related product when the flash point is below 110°C (230°F).

NOTE—Care should be taken in the interpretation of results obtained from solvent mixtures containing halogenated hydrocarbons (see Introduction above).

### Definition

*Flash Point (closed cup)*—Minimum temperature to which a product, confined in a closed cup, must be heated for the

vapors emitted to ignite momentarily in the presence of a flame, when operating under standardized conditions.

NOTE—In this international standard the flash point is corrected to an atmospheric pressure of 101.3 kPa (1013 mbar).

### Principle

*Method 1* (For liquids whose expected flash point is between ambient temperature and 110°C)—The test portion is heated in the specified apparatus. The ignition trial is carried out after the test portion has been maintained under equilibrium conditions for 60 s at a temperature approximately 3°C below the expected flash point.

The trial is repeated at other temperatures until a flash is observed at a temperature which is not more than 1°C above a temperature at which no flash was observed. The temperature at which the flash occurs is recorded as the flash point at the atmospheric pressure prevailing during the test and this temperature is then corrected to the standard atmospheric pressure of 101.3 kPa (1013 mbar).

*Method 2* (For liquids whose expected flash point is below ambient temperature)—The test portion is cooled to at least 3°C below the expected flash point and then, in the specified apparatus, an ignition trial is carried out as in Method 1 above after the test portion has been maintained under equilibrium conditions for 60 s.

The trial is repeated at other temperatures until a flash is observed at a temperature which is not more than 1°C above a temperature at which no flash was observed. The temperature at which the flash occurs is recorded as the flash point at the atmospheric pressure prevailing during the test and this temperature is then corrected to the standard atmospheric pressure of 101.3 kPa (1013 mbar).

## 7. ISO 3680-1983(E)—PAINTS, VARNISHES, PETROLEUM AND RELATED PRODUCTS—DETERMINATION OF FLASH/NO FLASH—RAPID EQUILIBRIUM METHOD.

NOTE—This Method is similar to ASTM D 3278 and D 3828 (see full reprints in chapter 2).

### Introduction

This international standard sets out one of two methods for the determination of danger classification. It should be read in conjunction with ISO 1516 when selecting a method for such a determination (see Section 2 above).

This method of test does not determine the flash point of the product under test, but merely its behavior at the selected equilibrium temperature as may be required to comply with laws or regulations relating to the storage, transport and use of flammable products. For this purpose it is unnecessary to determine the exact flash point but it is necessary to determine whether or not flashing occurs at a single given temperature.

In ISO 1516, a similar determination is specified, using cups as described in various national standards. The appa-

<sup>1</sup>Bell, L. H., *Journal of the Institute Petroleum*, Vol. 57, No. 556, July 1971.

<sup>2</sup>Rybicky, J. and Stevens, J. R., *Journal of Coatings Technology*, Vol. 53, No. 676, May 1981, pp. 40–42.

ratus specified in this international standard enables a similar result to be determined using a more rapid procedure and with a smaller test portion (2 mL) of material than that given in ISO 1516. Because of the small volume of test portion taken, thermal equilibrium is rapidly reached. In addition, the apparatus can be made portable to the extent of being suitable for on-site testing as well as for normal use in laboratories. Collaborative work<sup>3</sup> has shown that results obtained by these procedures are comparable.

### Scope and Field of Application

This international standard specifies a method for determining whether or not a flammable material such as a paint, varnish, paint binder, petroleum or a related product, at a specified temperature between 0 and 110°C (32 and 230°F) and under the conditions of test, gives off sufficient flammable vapor at this temperature to cause ignition on the application of an external source of flame applied in a standard manner.

### Principle

The test portion is heated in the specified apparatus. The ignition trial is carried out after the test portion has been maintained under equilibrium conditions for 60 s at the selected equilibrium temperature. This procedure ensures that the air/vapor space above the test portion has attained the saturation concentration of flammable vapor before the ignition trial is performed. The test report records whether the test portion at this temperature flashed or did not flash.

## 8. ISO 5280—XYLENE FOR INDUSTRIAL USE—SPECIFICATION

**WARNING**—Xylene is flammable and toxic by inhalation, ingestion or skin absorption.

### Scope and Field of Application

This international standard specifies requirements for xylene suitable for industrial purposes.

It is applicable to materials which consist essentially of xylene isomers [ $C_6H_4 \cdot (CH_3)_2$ ] and ethylbenzene ( $C_6H_5 \cdot C_2H_5$ ).

**NOTE**—For some purposes it may be desirable that the interested parties agree on the composition of the xylene.

### References

ISO 1523, *Paints, Varnishes, Petroleum and Related Products—Determination of Flash Point—Closed Cup Equilibrium Method*.

ISO 3679, *Paints, Varnishes, Petroleum and Related Products—Determination of Flash Point—Rapid Equilibrium Method*.

### Required Characteristic

The material shall conform to the characteristic shown in the table.

<sup>3</sup>L. H. Bell, *Journal of Institute of Petroleum*, Vol. 57, No. 556, July 1971.

Required Characteristic		
Characteristic	Requirement	Test method
Flash Point	If required, to be agreed between the interested parties	ISO 1523 or 3679

## 9. ISO 2431-1984(E)—PAINTS AND VARNISHES—DETERMINATION OF FLOW TIME BY USE OF FLOW CUPS.

**NOTE**—Just as in the United States, auxiliary ISO standards are specified in International Regulations of Hazardous Substances to define the flammability of liquids. One of these is ISO 2431. Various substances are classed in Packing Groups by flash point at various flash times.

### Introduction

The first edition of this international standard, published in 1972, specified only one flow cup of orifice diameter 4 mm. The second edition specified three flow cups of orifice diameter 3, 4, and 6 mm. This third edition corrects errors in figures 2 and 4 and the equations for those figures. Also this edition incorporates the corrections published by ISO in 1981. It is one of a series of standards dealing with the sampling and testing of paints, varnishes and related products.

As is well known, many countries over the years have developed their own standard flow cups and the difficulty in correlation between them has led to considerable confusion in comparing values. The standardization of an improved design of flow cup has been recommended after careful consideration, by an expert working group, of the role of flow cups for the measurement of flow time of paints, varnishes and related products.

It is recognized that the flow times are reproducible only for products of Newtonian or near-Newtonian flow properties. This effectively limits their practical use. Nevertheless, for checking purposes, these flow cups do serve a useful purpose. Furthermore, the measurement of flow time is often used to confirm the application consistency.

Paints often contain flow arresting agents to confer increased viscosity. Such paints exhibit anomalous flow properties that can only be properly assessed using viscometers operating at high velocity gradients.

Resins and varnishes, however, may exhibit Newtonian or near-Newtonian flow at much higher viscosities and, where this applies, flow cups can provide a useful means of controlling the consistency. To meet this requirement, this international standard provides flow cups suitable for viscosities up to about 700 mm<sup>2</sup>/s (700 cSt).

### Scope and Field of Application

This international standard specifies a method for the determination of the flow time of paints, varnishes and related products that may be used to control consistency.

Three flow cups of similar dimensions, but having orifice diameters of 3, 4 and 6 mm, are specified. The method for their calibration is given.



The method is limited to testing materials for which the breakpoint of the flow from the orifice of the flow cup can be determined with certainty. This point is difficult to determine and reproduce for materials with flow times in excess of 100 s due to slowing-down effects.

## Definitions

**Flow Time**—The elapsed time from the moment when the material under test starts to flow from the orifice of the filled cup to the moment when the flow stream of material first breaks close to the orifice.

**Newtonian Flow**—The type of flow exhibited by a material in which the ratio of the shear stress to the velocity gradient does not vary either with time or with the velocity gradient. When variations in this ratio are small, the effect on viscosity of mechanical disturbance, such as stirring, is negligible and the material is said to have near-Newtonian flow.

**Anomalous Flow**—The type of flow exhibited by a material in which, at a constant temperature, the ratio of the shear stress to the velocity gradient varies either with time or with rate of shear. For example, with so-called thixotropic materials, stirring or other such mechanical disturbance immediately before test will reduce the flow time below that for an unstirred sample. With such materials, uncertain and variable values for flow time are obtained in all flow cups.

**Dynamic Viscosity**—The ratio of the applied shear stress to the velocity gradient. The SI unit for dynamic viscosity is the pascal-second (Pa·s). The traditional unit is the centipoise (cP); 1 cP = 1 mPa·s.

**Kinematic Viscosity**—The ratio of the dynamic viscosity to the density of the liquid. The SI unit for kinematic viscosity is the square metre per second (m<sup>2</sup>/s). The traditional unit is the centistokes (cSt); 1 cSt = 1 mm<sup>2</sup>/s.

## Temperature Considerations

The effect of temperature on flow time is highly significant in respect of application properties and varies with the type of product.

For international reference purposes, it is essential to standardize one test temperature, and 23 ± 0.5°C (73.4 ± 0.9°F) is specified in this international standard. However, it may be more convenient to carry out comparative testing at some other agreed temperature, for example, 25°C (77°F), because of prevailing temperature conditions.

For control by flow time, it is normal practice to condition the test sample to an agreed temperature and to ensure that the temperature variation does not exceed 0.5°C (0.9°F) during testing.

## Apparatus (Flow Cups)

**Dimensions**—The dimensions of the ISO flow cups and the tolerances allowed in manufacture shall be as given in Fig. 1. The most critical tolerance is the internal diameter of the jet of the cup, because the flow time is inversely proportional to the fourth power of this dimension. The jet of the cup shall be made of stainless steel or sintered carbide unless otherwise specified, and the body of the cup shall be

made of a material which is corrosion resistant and is not affected by the products to be tested.

**Construction**—The dimensions not specified, such as wall thickness, shall be such that no distortion of the cup can occur in use. The external shape shown in Fig. 1 is recommended, but may be modified for convenience of use, or manufacture, provided that the protruding jet of the cup is protected from accidental damage as far as possible by an external protective sleeve. Such a protective sleeve shall not be immediately adjacent to the jet, so as to prevent a capillary action when the material under test flows out.

**Finish**—The interior surfaces of the cups, including the orifice, shall be smooth and free from turning marks, crevices, ledges and burrs which may cause random flow or trap sample or cleaning material. The standard of finish required is equivalent to a maximum roughness<sup>4</sup> of not more than 0.5 μm.

**Calibration**—Dimensionally similar cups will give, with Newtonian liquids, similar flow times, provided that the temperature of testing is precisely the same. The use of such liquids to calibrate cups provides a useful means of initially checking that dimensionally similar cups are within the accepted tolerances of performance and also for checking from time to time whether any wear or damage has taken place sufficient to bring a cup outside the accepted tolerances.

For calibration of any particular cup, use a standard oil<sup>5</sup> of known kinematic viscosity and draw a graph of kinematic viscosity versus temperature from the data given by the supplier for the oil.

Using the relevant procedure described in the procedure section, determine the flow time of the oil at a known temperature within the range from 20 to 30°C (68 to 86°F), measured to the nearest 0.1°C (0.2°F).

Record this flow time, which should be in the range 30 to 100 s and preferably near the mid-point of this range, to an accuracy of 0.1 s.

From the prepared graph, read the kinematic viscosity at the test temperature.

Using the appropriate calibration graph of Figs. 2, 3, or 4, read the flow time corresponding to this kinematic viscosity.

If the two values of flow time obtained do not differ by more than 3 percent, the cup may be deemed satisfactory for use.

For reference purposes, a correction factor corresponding to flow time deviation from that obtained using the oil may be applied.

**Care and Checking of Flow Cups**—Clean the cup immediately after use and before the sample starts to dry, using a suitable solvent. Never use metal cleaning tools or wire. If the orifice becomes contaminated with dried deposits, soften these with a suitable solvent and clean carefully, for example with a soft cloth pulled through the orifice.

Check the cups periodically for wear or damage by the calibration procedure specified in *Calibration* section.

<sup>4</sup>In the sense defined in ISO 468, i.e., the arithmetical mean deviation  $R_a$  from the mean line of the profile.

<sup>5</sup>Information on suppliers of suitable oils can be obtained from national standards organizations.

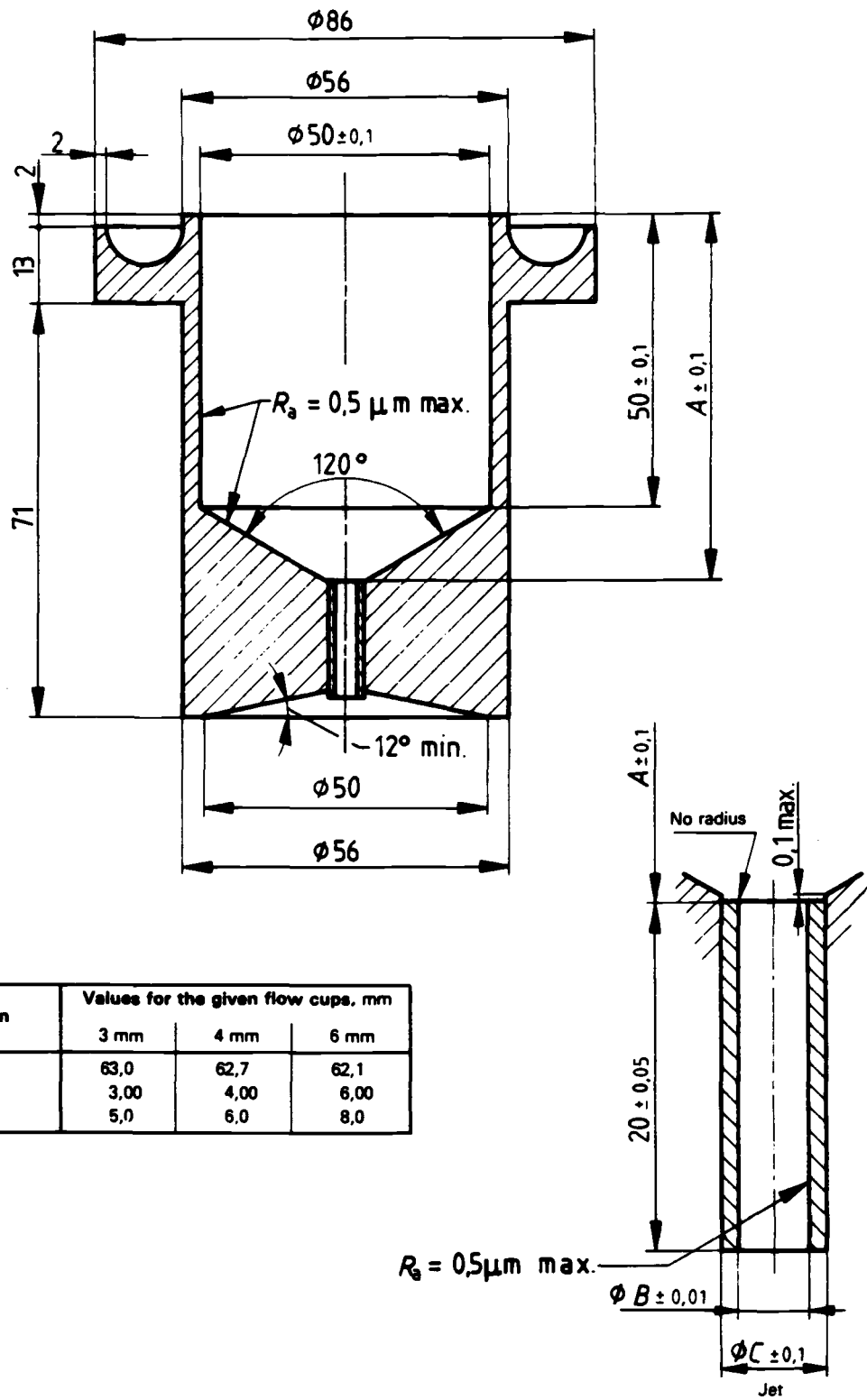

FIG. 1—Flow cup (ISO 2431).

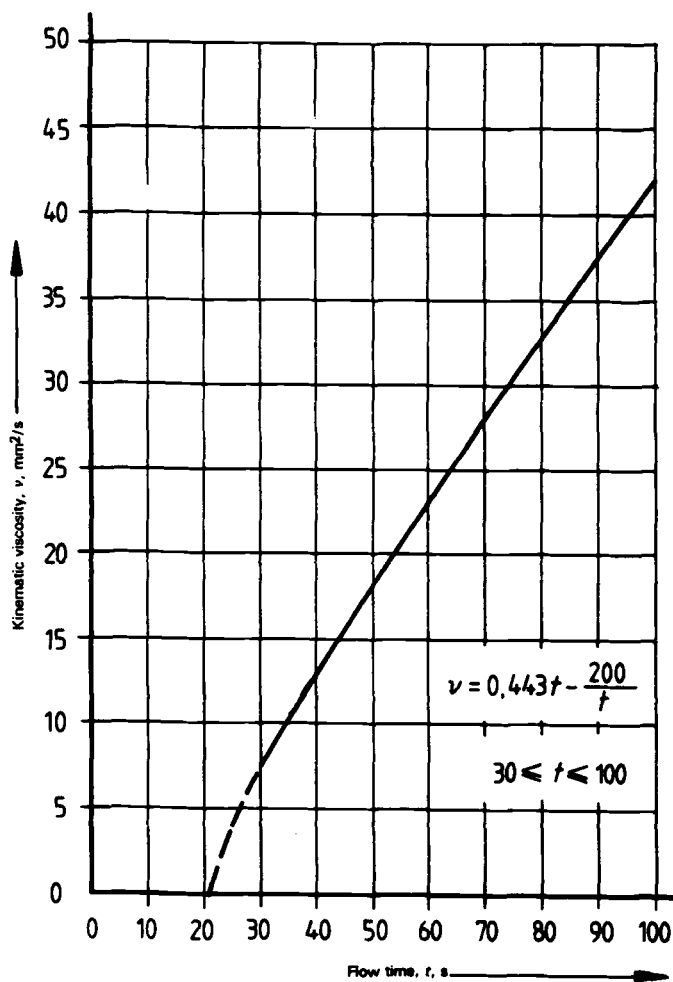

FIG. 2—Calibration curve for 3 mm cup.

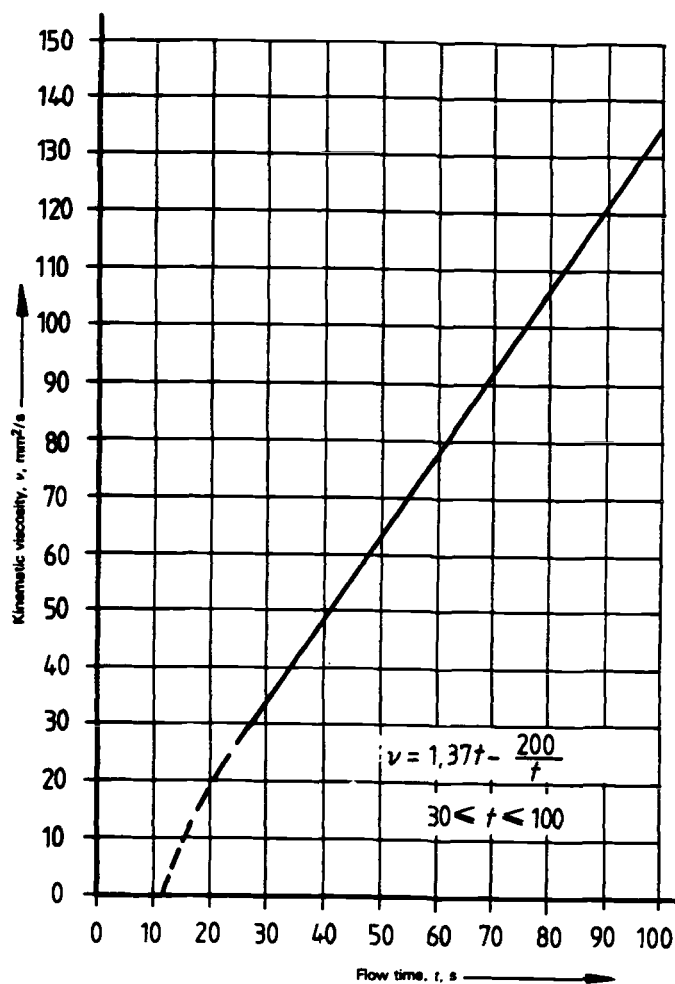

FIG. 3—Calibration curve for 4 mm cup.

### Apparatus (Supplementary)

*Thermometer*, accurate to 0.2°C (0.4°F) and graduated at 0.1°C (0.2°F) intervals.

*Stand*, suitable for holding the flow cup and provided with levelling screws.

*Spirit level*, preferably of the circular type.

*Flat glass plate or straight-edge scraper*.

*Stop-watch*, or other suitable timing-device with scale divisions of 0.5 s or finer and accurate to within 0.2 percent when tested over a 60 min period.

*Temperature-controlled room or enclosure*, capable of maintaining the cup and sample at a recommended, constant temperature (see Temperature Considerations section above).

### Sampling

Take a representative sample of the material to be tested. Before testing, it is advisable to strain the sample through an appropriate sieve into a clean dry container. This is mandatory for referee purposes. 150 mL of strained material is sufficient for carrying out one test. Take care to mix the material thoroughly, while at the same time avoiding, as far as possible, loss of solvent by evaporation.

### Procedure

*Preliminary Check*—This check is carried out to show that the material is suitable for the test (i.e. is Newtonian or near-Newtonian). Choose a flow cup that will give a flow time of between 30 and 100 s for the material.

Determine the flow time by the procedure, making sure that the material is well agitated before pouring into the cup. Remove the finger within 5 s of filling the flow cup.

Repeat the determination but this time allow the material to remain in the flow cup for 60 s before removing the finger.

If the second result differs from the first result by more than 10 percent, the material shall be deemed to be non-Newtonian and therefore unsuitable for consistency control by flow-time measurement.

*Determination of Flow Time*—Choose a flow cup that will give a flow time between 20 and 100 s, but preferably between 30 and 100 s, for the test material.

Adjust the temperature of the strained sample, and the flow cup, to  $23 \pm 0.5^\circ\text{C}$  ( $73.4 \pm 0.9^\circ\text{F}$ ) or to an alternative agreed temperature (see *Temperature Considerations* section). If the temperature-controlled enclosure is used, as recommended, it is advisable to condition the cup and the sample before straining, by placing them in the enclosure before use. The sample shall be considered ready for test

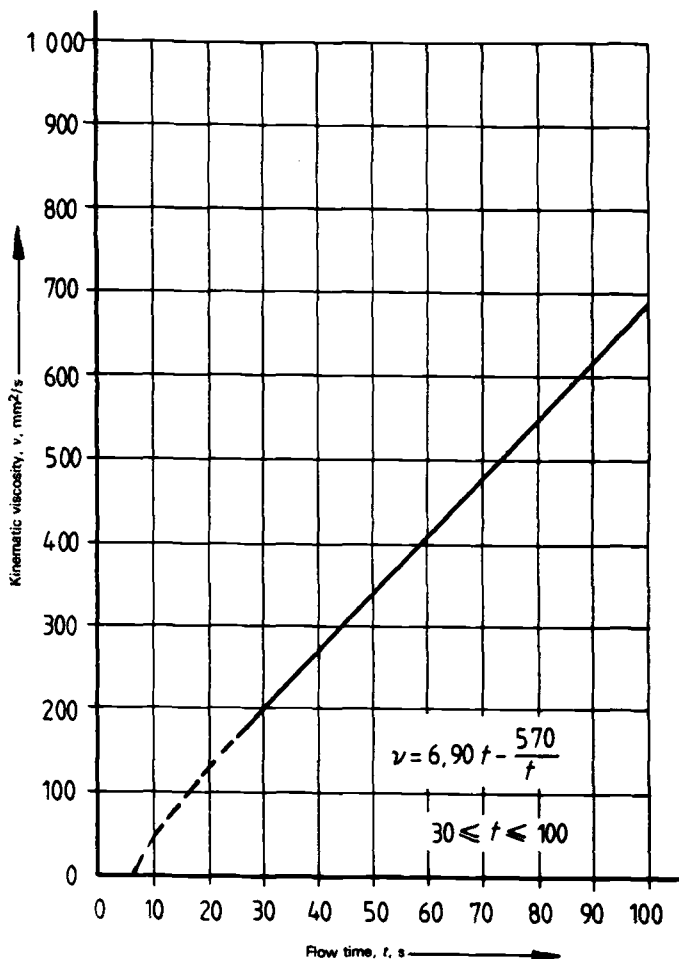

FIG. 4—Calibration curve for 6 mm cup.

immediately after any air bubbles entrained during the preparation and sieving procedures have dispersed. Carry out a final check that the temperature of the sample is within  $0.5^\circ\text{C}$  ( $0.9^\circ\text{F}$ ) of the agreed test temperature immediately prior to filling the cup.

Place the flow cup on the stand, in a position free from drafts and, by using the spirit level and adjusting the levelling screws of the stand, ensure that the upper rim of the flow cup is in a horizontal plane.

With the orifice closed by a finger, fill the cup with the freshly strained, bubble-free sample, pouring slowly to avoid the formation of air bubbles. If any bubbles are formed, allow them to rise to the surface and remove them. If the cup has been properly levelled, the sample will overflow evenly over the rim into the gallery. Remove any meniscus formed either by drawing the straight-edge scraper over the entire rim of the cup or by sliding over the rim a flat glass plate with rounded edges so that no air bubbles form between the glass and the surface of the sample. Then draw this plate

horizontally across the rim of the cup so that, when the plate is removed, the level of the sample coincides with the top rim of the cup.

Place a suitable receiver under the flow cup so that the distance between the orifice of the flow cup and the surface of the received sample is never less than 100 mm. Remove the finger from the orifice and simultaneously start the timing-device stopping it as soon as the first break occurs in the stream of sample close to the orifice. Record the flow time to the nearest 0.5 s.

If the test is not carried out in the temperature-controlled enclosure, place the thermometer in the stream of sample so as not to interfere with observation of the break in the flow.

This is conveniently done by holding the thermometer in a suitable clamping device with the bulb so placed that it is at an angle of the direction of flow and completely immersed in the emergent stream and not less than 100 mm from the orifice. It is convenient to use the same thermometer as is used to adjust the temperature of the sample initially. Any difference in temperature from the initially adjusted temperature shall not be greater than  $0.5^\circ\text{C}$  ( $1.0^\circ\text{F}$ ).

Carry out a second determination on another portion of the originally prepared sample and check carefully that the temperature of testing is within the prescribed limits. Record the flow time to the nearest 0.5 s. Calculate the mean of the two determinations.

If the two determinations differ by more than 5 percent, carry out a third determination. If the third determination and either of the previous determinations do not differ by more than 5 percent, discard the other determination. Calculate the result as the mean of the two accepted determinations.

If the third determination does not provide this measure of agreement, the method of test is unlikely to be suitable because of anomalous flow behavior, and consideration shall be given to other methods of test.

## PRECISION

The precision of the method, as obtained by statistical examination of interlaboratory test results, is as follows:

**Repeatability ( $r$ )**—The difference between two results (each the mean of two accepted determinations) obtained by the same operator with the same apparatus under constant operating conditions on identical test material shall, at the 95 percent confidence level, not exceed 5 percent.

**Reproducibility ( $R$ )**—The difference between two results (each the mean of two accepted determinations) obtained by different operators in different laboratories on identical test material shall, at the 95 percent confidence level, not exceed 10 percent.

# Regulations of International Regulatory Agencies

## INTRODUCTION

In international transportation of dangerous goods or hazardous materials, there are three international organizations involved in the regulation of the transportation of the materials in international trade: 1) the International Civil Aviation Organization (ICAO), 2) the International Maritime Organization (IMO), and 3) the European Highway (ADR) and Rail (RID) Transport Committee. In addition, the United Nations "Committee of Experts on the Transport of Dangerous Goods," working under the auspices of the U.N. Economic and Social Council (ECOSOC) located in New York with operational support provided by the Economic Commission for Europe (ECE) located in Geneva, Switzerland, has prepared recommendations for the transport of these materials.

ICAO and IMO regulations are based totally on the U.N. recommendation, while, as of 1991, the ADR/RID Committee is moving toward adoption of the U.N. Regulations.

## 1. RECOMMENDATIONS OF THE UNITED NATIONS, ECONOMIC AND SOCIAL COUNCIL, NEW YORK, NY

U.N. recommendations for the transport of hazardous materials are published in a book titled, "Transport of Dangerous Goods, Recommendations of the Committee of Experts on the Transport of Dangerous Goods," third revised edition, 1984. It is commonly known as the "Orange Book." The recommendations in this book are not to be considered as international regulations. However, as a result of concerted efforts, the U.N. recommendations have been or are being adopted by international organizations as regulations. Excerpts from the "Orange Book" are given below.

### 1.1 Scope of the Recommendations

#### *Nature, Purpose and Significance of the Recommendations*

These recommendations have been developed in the light of technical progress, the advent of new substances and materials, the exigencies of modern transport systems and, above all, the requirement to ensure the safety of people, property and the environment. They are addressed to gov-

ernments and international organizations concerned with the regulation of the transport of dangerous goods. Among other aspects, the recommendations cover principles of classification and definition of classes, listing of the principal dangerous goods, general packing requirements, testing procedures, marking, labeling or placarding, and shipping documents. In addition, there are special recommendations related to particular classes of goods. Nevertheless, they do not apply to dangerous goods in bulk which, in most countries, are subject to special regulations.

These recommendations present a basic scheme of provisions that will allow national and international regulations governing the various modes of transport to develop within it in a uniform fashion; yet they remain flexible enough to accommodate any special requirements that might have to be met. It is expected that governments, intergovernmental organizations and other international organizations, when revising or developing regulations for which they are responsible, will conform to the principles laid down in these recommendations, thus contributing to worldwide harmonization in this field.

The scope of the recommendations should ensure their value for all who are directly or indirectly concerned with the transport of dangerous goods. With this system (of classification, listing, packing, marking, labeling, placarding and shipping documentation) in general use, carriers, consignors and inspecting authorities will benefit from simplified transport, handling and control, and from a reduction in time-consuming formalities. In general, their task will be facilitated and obstacles to the international transport of such goods reduced accordingly. At the same time, the advantages will become increasingly evident with the steadily growing trade in goods categorized as "dangerous."

### 1.2 Principles Underlying the Regulation of the Transport of Dangerous Goods

Transport of dangerous goods is regulated in order to prevent, as far as is possible, accidents to persons or property and damage to the means of transport employed or to other goods. At the same time, regulations must be framed so as not to impede the movement of such goods, other than those too dangerous to be accepted for transport. With this exception, the aim of regulations is to make transport feasible by eliminating risks or reducing them to a minimum. It is a matter, therefore, of safety and of facilitating transport.

### 1.3 Desirability of Uniformity at the World Level for All Modes of Transport

If the main systems of regulation differ in their bases for classification (and corresponding labeling), listing of goods, and their terminologies, then any such discrepancies would create difficulties for exporters whose consignments might need to comply with the heterogeneous regulations of countries of transit and destination, or different modes. This would also complicate the task of inspecting authorities. But harmonized systems using these recommendations as their *modus operandi* would avoid these difficulties and would aid rather than confuse the user.

If the consignor does not have to face a multiplicity of provisions relating to packaging and stowing, especially in connection with international transport, then his function is rendered both more effective and more economic.

Lastly, if during the journey from the consignor to the consignee more than one mode of transport is used successively for the goods, then harmonization of the regulations for the different modes renders carriage of such goods more efficient and undoubtedly safer.

### 1.4 Classification and Definitions of Classes of Dangerous Goods

The classification of goods by type of risk involved has been drawn up to meet technical conditions, while at the same time minimizing interference with existing regulations. It should be noted that the numerical order of the classes is not that of the degree of danger.

The objective of the recommended definitions is to indicate which goods are dangerous and in which class, according to their specific characteristics, they should be included. These definitions have been devised so as to provide a common pattern which it should prove possible to follow in the various national and international regulations. Used with the list of dangerous goods, the definitions should provide guidance to those who have to use such regulations. The definitions present a notable degree of standardization, while retaining a flexibility that allows diverse situations to be taken into account.

Unless there is an explicit or implicit indication to the contrary in the recommendations, viscous substances with an outflow time from a DIN-CUP with 4 mm I.D. outlet at 20°C (68°F) exceeding 10 min or more than 690 s at 20°C (68°F) from a Ford 4 cup or with a viscosity of more than 2,680 centistokes at 20°C (68°F) should be considered as solid substances.

NOTE—Refer to ASTM D 1200, *Test Method for Viscosity of Paints, Varnishes, and Lacquers by Ford Viscosity Cup*, for details.

Dangerous goods are defined according to the following classes:

- Class 1—Explosives.
- Class 2—Gases (compressed, liquified, dissolved under pressure or deeply refrigerated).
- Class 3—Inflammable (flammable) liquids.
- Class 4—Inflammable (flammable) solids (substances

liable to spontaneous combustion and substances which, on contact with water, emit inflammable gases).

- Class 5—Oxidizing substance, organic peroxides.
- Class 6—Poisonous (toxic) and infectious substances.
- Class 7—Radioactive substances.
- Class 8—Corrosives.
- Class 9—Miscellaneous dangerous substances.

For Class 3 Inflammable liquids, the word “flammable” has the same meaning as “inflammable.” Inflammable liquids are liquids, or mixtures of liquids, or liquids containing solids in solution or suspension (for example, paints, varnishes, lacquers, etc., but not including substances otherwise classified on account of their dangerous characteristics) which give off an inflammable vapor at temperatures of not more than 60.5°C (141°F) in a closed-cup test or not more than 65.6°C (150°F) in an open-cup test.

Since the results of open-cup and closed-cup tests are not strictly comparable and even individual results by the same test are often variable, regulations varying from the above figures to make allowance for such differences would be within the spirit of this definition.

### 1.5 Special Recommendations Relating to Class 3 Inflammable Liquids

#### General Notes

Substances are listed in this class only when their flash point is equal to or less than 60.5°C (141°F) in a closed-cup test or not more than 65.6°C (150°F) in an open cup-test. It may be observed, however, that the flash point of an inflammable liquid may be altered by the presence of an impurity. Substances listed in this class by name should be regarded as chemically pure.

In addition to classifying hazardous substances by classes, Class 3 materials are classified by a packing group number. (See Table 1 below).

In practice, however, goods shipped under the name of such substances are often commercial products which contain other added substances or impurities. Therefore, it may occur that liquids which are not included in the list because their flash point in their pure state is more than 60.5°C (141°F) in a closed-cup test or more than 65.6°C (150°F) in an open-cup test may be offered for transport as commercial products with a flash point at or below that limit. Moreover, liquids which would be listed, in their pure state, in Packing Group III could in fact be included in Packing Group II as commercial products because of the presence of added substances or impurities.

For these reasons caution must be exercised when using the lists of products which are only guides. In the event of doubt, the flash point of substances should be tested experimentally.

Table 1 should be used for the determination of the hazard grouping of a liquid that presents a risk due to inflammability. For liquids whose only risk is inflammability, the packing group for the substance is the hazard grouping shown in the table. For a liquid with an additional risk(s), the hazard group determined from the table and the hazard group based on the severity of the additional risk(s) should be considered. In such cases, the Table of Precedence of Hazard Characteristics appearing in Table 2 should be used

TABLE 1—Hazard Grouping Based on Inflammability.

Packing Group	Flash Point (Closed-cup)		Initial Boiling Point	
	°C	°F	°C	°F
I	..	..	≤35	≤95
II	<23	<73	>35	>95
III	≥23–≤60.5	≥73–≤141	>35	>95

to determine the correct packing group of the liquid. The hazard grouping indicating the highest degree of danger based on the different risks of a substance then becomes the packing group for the substance.

#### Methods Used for Determining the Flash Point of Substances in Class 3

The following is a list of documents describing methods used in certain countries for determining the flash point of substances in Class 3.

*France*—Instructions annexed to the ministerial decree (France) of 26 October 1925 issued under the authority of the Ministère du commerce et de l'industrie (*Journal Official* of 29 October 1925).

*Federal Republic of Germany* (Deutscher Normenausschuss, Berlin W.15, Uhlandstasse 175—Standard DIN 51755 (flash points below 65°C (149°F); Standard DIN 51758 (flash points 65 to 165°C (149 to 329°F); and Standard DIN 53213 (for varnishes, lacquers and similar viscous liquids with flash points below 65°C (149°F).

*Union of Soviet Socialist Republics* (State Committee of the USSR Council of Ministers for Standardization, 113813, GSP, Moscow, M-49 Leninsky Prospect, 9)—GOST 6356-75; GOST 4333-48; and GOST 12.1.02.1-80.

*United Kingdom* (Institute of Petroleum, 61 New Cavendish Street, London, W.I.)—Standard Method No. 33/44; and Standard No. 34/47.

*United States of America* (ASTM, 1916 Race Street, Philadelphia, PA 19103)—ASTM D 56; ASTM D 3278; and ASTM D 93.

#### Classification of Articles and Substances with Multiple Hazards

The Precedence of Hazards Table 2 indicates which of two hazards must be regarded as the primary hazard. The class or division which appears at the intersection of relevant line and column is the primary hazard and the other class or division is the subsidiary hazard. The most stringent packing group based in the different hazards of a material must then be the packing group for the article or substance and

this is shown next to the primary hazard at the intersection of the relevant line and column.

NOTE—Table 2 is based on the U.N. Precedence Table, which is not reproduced in total.

#### Determination of Grouping of Inflammable Viscous Substances With a Flash Point of Less Than 23°C (73°F)

The hazard group of paints, varnishes, enamels, lacquers, adhesives, polishes and other viscous inflammable substances of Class 3 with a flash point of less than 23°C (73°F) is determined by reference to: the viscosity expressed as the flowtime in seconds; the closed-cup flash point; a solvent separation test; and the size of the receptacle.

#### Criteria for Inclusion of Viscous Inflammable Liquids in Packing Group III

Viscous inflammable liquids such as paints, enamels, varnishes, adhesives and polishes with a flash point of less than 23°C (73°F) are included in Packing Group III provided that: 1) less than 3 percent of the clear solvent layer separates in the solvent separation test; 2) the mixture contains not more than 5 percent of substances in Group I or Group II of the Toxic or Corrosive Class or 5 percent of substances of Group I of Class 3 requiring a toxic or corrosive subsidiary label; 3) the viscosity and flash point are in accordance with Table 3 below; and 4) the capacity of the receptacle used is not more than 30L (6.6 gal).

The test methods used are as follows.

*Viscosity Test*—The flow time in seconds is determined at 23°C (73°F) using the 150 standard cup with 4 mm (0.16 in.) jet as detailed in ISO 2431, *Paints and varnishes—Determination of Flow Time by Use of Flow Cups* (see Section 9 of Chapter 14 above for partial reprint). Where the flow time exceeds 200 s, a second test is carried out using the ISO standard cup but modified to take a jet of 8 mm (0.31 in.) diameter.

*Flash Point*—The closed-cup flash point is determined according to the ISO Method ISO 1523, *Paints, varnishes, petroleum and related products—Determination of Flash Point—Closed-Cup Equilibrium Method* (see section 3 of Chapter 14 above for partial reprint). Where the temperature of the flash point is too low for the use of water in the water bath, the following modifications should be made:

(1) Use ethylene glycol in the water bath or other suitable similar containers;

TABLE 2—Precedence of Hazards and Packing Groups for Classes 3 and 8 and Division 6.1.

Class or Division	Packing Group	6.1	6.1	6.1	6.1	6.1	8	8	8
		(i)	(d)	(o)	6.1	6.1	(L)	(L)	(L)
		I	I	I	II	III	I	II	III
3	I	6.1.1	3.1	3.1	3.1	3.1	3.1	3.1	3.1
3	II	6.1.1	3.1	3.1	3.11	3.1	8.1	3.11	3.11
3	III	6.1.1	6.1.1	6.1.1	6.1.11	6.1.111 <sup>a</sup>	8.11	8.111	8.111

NOTES: (L) liquid, (i) inhalation, (d) dermal, (o) oral.

Class 3, Flammable Liquid.

Class 6, Division 6.1, Poisonous (Toxic) Substances.

Class 8, Corrosives.

<sup>a</sup>For pesticides only, for all other substances 3.111 is the primary hazard.

**TABLE 3**—Criteria for Flammable Viscous Substances.

Flowtime in Seconds		Flash point in °C (°F)
4 mm Cup	8 mm Cup	
Over 20	...	Over 17 (63)
Over 60	...	Over 10 (50)
Over 100	...	Over 5 (41)
Over 160	...	Over -1 (30)
Over 220	Over 17	Over -5 (23)
...	Over 40	No lower limit

(2) Where appropriate, a refrigerator may be used to cool the sample and apparatus to below the temperature required by the method for the expected flash point. For lower temperatures, the sample and equipment should be cooled to a suitable temperature, for example, by adding solid carbon dioxide slowly to the ethylene glycol with the sample being similarly cooled in a separate container of ethylene glycol;

(3) In order to obtain reliable flash points, it is important that the recommended rate of temperature rise for the sample during testing is not exceeded. Depending on the size of the water bath and the amount of ethylene glycol it contains, it may be necessary partially to insulate the water bath to achieve a sufficiently slow rate of temperature rise.

*Solvent Separation Test*—This test is carried out at 23°C (73°F) using a 100 mL measuring cylinder of the stoppered type of approximately 250 mm (9.8 in.) total height and of a uniform internal diameter of approximately 30 mm (1.2 in.) over the calibrated section. The paint should be stirred to obtain a uniform consistency and poured in up to 100 mL (3.5 fl. oz) mark. The stopper should be inserted and the cylinder left standing undisturbed for 24 h. After 24 h, the height of the upper separated layer should be measured and the percentage of this layer as compared with the total height of the sample calculated.

## 2. INTERNATIONAL CIVIL AVIATION ORGANIZATION, 1000 SHERBROOKE STREET WEST, SUITE 400, MONTREAL, QUEBEC, CANADA H3A 2R2.

The following paragraphs are reprinted with permission from ICAO.

The broad principles governing the international transport of dangerous goods by air are contained in Annex 18 to the Convention on International Civil Aviation. ICAO's *Technical Instructions for the Safe Transport of Dangerous Goods by Air* (Document 9284-AN/905) amplify the basic provisions of Annex 18 that define and classify flammable liquids.

It is intended that the Technical Instructions will be kept up to date by an ICAO body of experts. For this purpose the ICAO Dangerous Goods Panel will continue to meet at least annually to review comments received from states and interested international organizations, to consider any changed recommendations of the United Nations Committee of Experts on the Transport of Dangerous Goods and to prepare a new edition of the Technical Instructions. Amendments recommended by the Dangerous Goods Panel will be reviewed

by the Air Navigation Commission. The Council of ICAO will then consider, with a view to approval, the amended version of the Technical Instructions and authorize their publication.

NOTE—Since these ICAO Technical Instructions are based wholly on the U.N. "Orange Book" excerpts given in Section 1 of this chapter, they need not be reprinted in this section. The most recent revisions of these instructions can be obtained directly from ICAO.

## 3. INTERNATIONAL MARITIME ORGANIZATION (IMO), 101-104 PICCADILLY, LONDON W1V 0AE, ENGLAND.

### 3.1 Introduction to the International Maritime Dangerous Goods Code (IMDG)

The IMDG Code is designed to assist compliance with the general requirement of the International Convention for the Safety of Life at Sea (SOLAS) regarding the carriage of dangerous goods by sea (Chapter VII). The IMDG Code is also intended to be the basis for individual requirements in order to provide harmonization between countries engaged in such trade.

The carriage of dangerous goods in ships has increased substantially since the Second World War owing to the enormously increased use of many of these goods. Transport by sea of dangerous goods is regulated in order reasonably to prevent injury to persons, or damage to the ship. At the same time, however, any regulations should be so framed as not to impede unnecessarily the movement of such goods.

In many maritime countries measures have been taken over the years to regulate, by legislation, or by recommendations, the carriage of dangerous goods in ships. These various codes and practices, however, differ in their framework and in the labeling of goods. The terminology is different and the provisions for packaging and storage may also vary from country to country. This somewhat complicated situation has created difficulties for all who are in any way directly or indirectly concerned with the transport of dangerous goods.

The need for international regulation of the carriage of dangerous goods by sea was recognized by the 1929 International Conference on Safety of Life at Sea, which recommended that rules on the subject should have international effect. A classification of dangerous goods and certain general provisions concerning their carriage in ships were adopted by the Safety of Life at Sea Conference in 1948. This Conference also recommended further study with the object of drafting international regulations.

Meanwhile, in 1956, the United Nations Committee of Experts on the Transport of Dangerous Goods, which had been actively considering the international aspect of the carriage of dangerous goods by all forms of transport, completed a report dealing with the classification, listing and labeling of dangerous goods and with the transport documents required for such goods. This report, with subsequent modifications, offered a general framework to which existing regulations could be adapted and within which they



could develop, the ultimate aim being world-wide uniformity for maritime and other forms of transport.

As a further step towards meeting the need for international rules governing the carriage of dangerous goods in ships, the International Conference on Safety of Life at Sea recommended that IMO undertake a study with a view to establishing a unified international code for the carriage of dangerous goods by sea. This study should be pursued in cooperation with the U.N. Committee of Experts and should take account of existing maritime practices and procedures.

To implement the recommendation, IMO's Maritime Safety Committee appointed a working group drawn from those countries having considerable experience in the carriage of dangerous goods by sea. These drafts were subsequently brought under close scrutiny by the working group, which has taken into account the practices and procedures of a number of maritime countries in order to make the code as widely acceptable as possible. This code has been approved by the Maritime Safety Committee and recommended to governments by Assembly of IMO.

The recommendations of the U.N. Committee of Experts on the Transportation of Dangerous Goods have been incorporated into the code, except that IMO divides Class 3 into several subdivisions, as detailed below.

### 3.2 Definitions of Class 3 Inflammable Liquids

Class 3 deals with liquids, or mixtures of liquids, or liquids containing solids in solution or suspension (e.g. paints, varnishes, lacquers, etc. but not including substances which, on account of their other dangerous characteristics, have been included in other classes) which give off an inflammable vapor at or below 61°C (141°F) in a closed-cup test (corresponding to 65.6°C (150°F) in an open-cup test).

#### *Division of the Substances into Groups According to Flash Point*

*Class 3.1*—Low flash point group of liquids having a flash point of below -18°C (0°F).

*Class 3.2*—Intermediate flash point group of liquids having a flash point of -18°C (0°F) up to, but not including, 23°C (73°F).

*Class 3.3*—High flash point group of liquids having a flash point of 23°C (73°F) up to, and including, 61°C (141°F).

Substances which have a flash point above 61°C (141°F) are not considered to be dangerous by virtue of their fire hazard.

The flash points herein designated are based upon the closed-cup flash point test. Equivalentents determined by the open-cup test may be specified, and the method of test prescribed, by individual national codes. "Inflammable" has the same meaning as flammable.

### 3.3 Standardization of the Flash Point Test Method

The flash point of an inflammable liquid is the lowest temperature of the liquid at which its vapor forms an ignitable mixture with air. The flash point should not be confused with the ignition temperature which is the temperature to which an explosive vapor-air mixture must be heated to

cause actual explosion. There is no relationship between the flash point and the ignition temperature). It gives a measure of the risk of formation of explosive or ignitable mixtures when the liquid escapes from its packaging. An inflammable liquid cannot be ignited so long as its temperature remains below the flash point.

The flash point is not an exact physical constant for a given liquid. It depends to some extent on the construction of the test apparatus used and on the testing procedure. Therefore, flash point data should specify the name of the test apparatus.

Several standard apparatuses are in current use. They all operate on the same principle: a specified quantity of the liquid is introduced into a receptacle at a temperature well below the flash point to be expected, then slowly heated; periodically a small flame is brought near to the surface of the liquid. The flash point is the lowest temperature at which a "flash" is observed.

The test methods can be divided into two major groups, depending on the use in an apparatus of an open receptacle (open-cup methods), or a closed one which is only opened to admit the flame (closed-cup methods). As a rule the flash points found in an open-cup test are a few degrees higher than in a closed-cup test.

*Closed-cup methods* are, among others:

- The Abel apparatus, specified in the British standards BS 3442, IP 33, and IP 170; or the French standards AFNOR M 07-011, and AFNOR T 66-009.
- The Abel-Pensky apparatus, specified in the German standard DIN 51755; or the French standard AFNOR MO 07-019.
- The Pensky-Martens apparatus (closed) specified in the U.S. standard ASTM D 93; in the German standard DIN 51758; or in the British standards IP 34 and BS 2839.
- The Luchaire apparatus, specified in the French standard AFNOR T 60-103.

*Open-cup methods* are, among others:

- The Cleveland apparatus, specified in the British standard IP 36; U.S. standard ASTM D 92; or the French standard AFNOR T 60-118.
- The Pensky-Martens apparatus (open), specified in the British standard IP 35.
- The Tag apparatus specified in the U.S. standard ASTM D 1310.

Notwithstanding, the detailed description of standardized test apparatus and methods, the reproducibility of the result is far from ideal. In general, reproducibility in closed-cup apparatus is better than in open-cup.

It is, therefore, recommended that flash points, especially in the range around 23°C (73°F), should be determined by means of closed-cup methods.

Flash point data in this Code are generally based on closed-cup methods. In countries where it is customary to determine flash points by the open-cup method, the temperatures given by that method would need to be reduced to correspond with those in this Code.

#### *Packing Classification and Grouping Criteria*

Inflammable liquids have for packing purposes been apportioned among three categories (packaging groups)

according to the degree of danger they present as follows: great danger (Packaging Group I), medium danger (Packaging Group II) and minor danger (Packaging Group III). The packaging group to which a substance is assigned is given on the individual schedule.

The packaging group of an inflammable liquid not listed by name should be assigned in accordance with those in Table 1 of Section 1.5. Inflammable liquids are grouped for packing purposes according to their flash point, their boiling point and their viscosity. The table shows the relationship existing between two of these characteristics.

NOTE—The IMO text on “Classification of Articles and Substances with Multiple Hazards;” Determination of Groupings of Inflammable Viscous Substances with a Flash Point of Less than 23°C (73°F);” and “Criteria for Inclusion of Viscous Inflammable Liquids in Packaging Group III” is identical to the U.N. “Orange Book” text of the same sections given above. Therefore, those IMO sections will not be repeated here (see Section 1.5 above for that information).

#### 4. EUROPEAN HIGHWAY (ADR) AND RAIL (RID) TRANSPORT COMMITTEE, UNITED NATIONS, ECONOMIC COMMISSION FOR EUROPE (ECE); PALAIS DES NATIONS; CH-1211 GENEVA 10; SWITZERLAND.

The Transport Division of the ECE provides the Secretariat for two main bodies.

1. *The Group of Experts on the Transport of Dangerous Goods*, which elaborates on the European road regulations in this field: ADR—European Agreement concerning the International Carriage of Dangerous Goods by Road, the ADN—provisions developed for inland waterways, and, in association with the RID Safety Committee, the virtually identical regulations for rail transport.

2. *The United Nations Committee of Experts on the Transport of Dangerous Goods*.

The requirements for determining flash point are the same for ADR, ADN, and RID.

The following excerpt is from the ADR document entitled, European Agreement Concerning the International Carriage of Dangerous Goods by Road (ADR) and Protocol Signature, Geneva, Switzerland, 30 Sept. 1957, Vol. I, Annex A, published by the United Nations in 1985. Reference should be made to the regulations of the ADR, ADN, and RID for the exact text and for exceptions listed there. These regulations may be obtained from the Transport Division of ECE, or especially, for RID Regulations from the Department of Transport (FRH2), 2 Marsham Street, London SW1 P3 EB, England.

##### 4.1 Definitions

*Liquids*—Substances and mixtures which are liquid or viscous at a temperature not exceeding 35° (95°F).

*Inflammable Liquids*—Liquids which have a vapor pres-

sure not exceeding 300 kPa (225 mm Hg) (3 bar) at a temperature of 50°C (122°F) and a flash point not exceeding 100°C (212°F), except those flammable liquids which, because of supplementary dangerous properties, are listed in or assigned to other classes of dangerous substances.

*Very Dangerous Substances*—Inflammable liquids having a boiling or initial boiling point not exceeding 35°C (95°F), and having a flash point below 21°C (70°F), which are either highly toxic or highly corrosive.

*Dangerous substances*—Inflammable liquids having a flash point below 21°C (70°F) which are not listed as a very dangerous substance.

*Substances Presenting a Minor Danger*—Inflammable liquids having a flash point of 21°C (70°F) to 100°C (212°F).

NOTE—When as a result of additions, the flash point, boiling point, initial boiling point or vapor pressure of an inflammable substance is not within the limits prescribed for the items defined above, such mixture shall be classified on the basis of its flash point, boiling point, initial boiling point or vapor pressure as actually determined.

##### 4.2 Test for Determining Flash Point

The flash point is determined by means of one of the following types of apparatus: 1) for use at temperatures not exceeding 50°C (122°F)—Abel, Abel-Pensky, Luchoire-Finances, Tag; 2) for use at temperatures above 50°C (122°F)—Pensky-Martens, Luchoire-Finances; or 3) failing these, any other closed-cup apparatus capable of giving results within 2°C (4°F) of those which an apparatus listed above would give at the same place.

To determine the flash point of paints, gums and similar viscous products containing solvents, only apparatus and test methods suitable for determining the flash point of viscous liquids may be used, such as The Institute of Petroleum's (IP) Method A of IP 170 and TGL 14 301, leaflet 2.

The test procedure shall be:

1. For the Abel apparatus, that of IP 33, *Flash Point by the Abel Apparatus-Petroleum*; this standard may also be used for the Abel-Pensky apparatus;

2. For the Pensky-Martens apparatus, that of IP 34, *Flash Point by the Pensky-Martens Closed Tester* or that of ASTM D 93, *Test Methods for Flash Point by Pensky-Martens Closed Tester*.

3. For the Tag apparatus, that of ASTM D 56, *Test Method for Flash Point by Tag Closed Tester*.

4. For the Luchoire apparatus, that of the Instruction annexed to the ministerial order (arrêté ministériel) (France) of 26 October 1925 issued by the *Ministère du Commerce et de l'Industrie* and published in the *Journal Officiel* of 29 October 1925.

If any other apparatus is used the following precautions must be taken:

1. The test must be performed in a place free from drafts.

2. The rate of temperature increase of the liquid being tested must never exceed 5°C (9°F) per min.

3. The pilot-flame must be 5 mm ( $1 \pm 0.5$  mm) long.

4. The pilot-flame must be applied to the opening of the receptacle after each rise of 1°C (2°F) in the temperature of the liquid.

In the event of a dispute as to the classification of a flammable liquid, the item number proposed by the sender shall be accepted if a check-test of the flash point, carried out on the liquid in question, yields a result not differing by more than 2°C (3.6°F) from the limits 21°C (70°F), 55°C (99°F), and 100°C (212°F), respectively. If a check-test yields a result differing by more than 2° (3.6°F) from these limits, a second check-test must be carried out, and the highest figure obtained shall be adopted.

### 4.3 Test for Determining Fluidity

To determine the fluidity of liquid or viscous substances and mixtures of Class 3, the following test method should be used.

#### *Test apparatus*

Commercial penetrometer conforming to ISO Standard 3237 with a guide rod of  $47.5 \pm 0.05$  g; sieve disc of duralumin with conical bores and a mass of  $102.5 \pm 0.05$  g; penetration vessel with an inside diameter of 72 mm to 80 mm for reception of the sample.

#### *Test procedure*

The sample is poured into the penetration vessel not less than half an hour before the measurement. The vessel, which is hermetically closed, is kept immobile until the measurement. The sample is heated in the hermetically closed penetration vessel to  $35^\circ\text{C} \pm 0.5$  K and is placed on the penetrometer table only directly before the measurement (not more than two minutes). The center S of the sieve disc is then brought into contact with the surface of the liquid and the penetration depth measured in relation to time.

#### *Evaluation of test results*

A substance shall not be subject to the conditions of Class 3 of ADR if, after the center S has been brought into contact with the surface of the sample, the penetration indicated by the dial gauge

(a) after a loading time of  $5 \text{ s} \pm 0.1 \text{ s}$ , is less than 15.0 mm  $\pm 0.3$  mm, or

(b) after a loading time of  $5 \text{ s} \pm 0.1 \text{ s}$ , is greater than 15.0 mm  $\pm 0.3$  mm, but the additional penetration after another  $55 \text{ s} + 0.5 \text{ s}$  is smaller than 5.0 mm  $\pm 0.5$  mm.

**NOTE**—In the case of samples having a flow point, it is often impossible to produce a plane surface in the penetration vessel and, hence, to fix clear initial measuring conditions for the contact of the center S. Furthermore, with some samples, the impact of the sieve disc can cause an elastic deformation of the surface and in the first few seconds simulate a deeper penetration. In all these cases it may be useful to make the evaluation mentioned in (b) above.

## 5. EUROPEAN ECONOMIC COMMUNITY, COMMISSION OF THE EUROPEAN COMMUNITIES, DIRECTORATE—GENERAL FOR THE ENVIRONMENT CIVIL PROTECTION AND NUCLEAR SAFETY, RUE DE LA LOR 200, B-1049 BRUSSELS, BELGIUM.

The following are excerpts of the Commission of the European Communities. These excerpts are drawn from two documents which both constitute the 6th Amendment of Directive 67/548/EEC. The Introduction/Definitions section was drawn from Directive 79/831/EEC, Article 2, while the section on flash point was drawn from Annex V of Directive 84/449/EEC. Both excerpts are reprinted here with permission from the commission of the European Communities.

### 5.1 Introduction/Definitions

The information provided in Directive 67/548/EEC is intended as a guide for all those concerned (manufacturers, importers, national authorities) with methods of classifying, packaging and labelling dangerous substances and preparations, which are placed on the market in the member states. It sets out the general principles governing the classification, packaging and labelling of substances and preparations.

The object of classification is to identify all the toxicological and physico-chemical properties of substances and preparations which may constitute a risk during normal handling or use.

The following substances and preparations within the scope of the compilation are "dangerous" within the meaning of the Directive, Article 2.

**Explosive**—Substances and preparations which may explode under the effect of flame or which are more sensitive to shocks or friction than dinitrobenzene.

**Oxidizing**—Substances and preparations which give rise to highly exothermic reaction when in contact with other substances, particularly flammable substances.

**Extremely Flammable**—Liquid substances and preparations having a flash point lower than 0°C and a boiling point (or in case of a boiling range the initial boiling point) lower than or equal to 35°C.

**Highly Flammable**—Substances and preparations which may become hot and finally catch fire in contact with air at ambient temperature without any applications of energy, or solid substances and preparations which may readily catch fire after brief contact with a source of ignition and which continue to burn or to be consumed after removal of the source of ignition; or liquid substances and preparations having a flash point below 21°C; or gaseous substances and preparations which are flammable in air at normal pressure; or substances and preparations which, in contact with water or damp air, evolve highly flammable gases in dangerous quantities at a minimum rate of 1 L/kg/h.

**Flammable**—Liquid substances and preparations having a flash point equal to or greater than 21°C and less than or equal to 55°C; however, in practice it has been shown that a preparation having a flash point equal to or greater than 21°C and less than or equal to 55°C need not be classified

as flammable if the preparation could not in any way support combustion and only so long as there is no reason to fear risks to those handling these preparations or to other persons.

## 5.2 Flash Point Determinations

NOTE—The Annex V to Commission Directive of 25 April 1984 (84/449/EEC) sets out test methods for the determination among others of those related to flash point and to flammability hazards. These methods are based on those recommended by the International Body Organization for Economic Cooperation and Development (OECD).

### Introduction

It is useful to have preliminary information on flammability of the substance to perform this test. The test procedure is applicable to liquid substances, as marketed, whose vapors can be ignited by ignition sources. The test methods described in this text are only reliable for flash point ranges which are specified in the individual methods.

### Definition

The flash point is the lowest temperature, corrected at a pressure of 101.325 kPa, at which the test liquid in a closed test vessel evolves vapors, under the conditions defined in the test method, in such amount that a flammable vapor/air mixture is produced in the test vessel.

### Reference Substances

Reference substances do not need to be used in all cases when investigating a new substance. They should primarily serve to calibrate the method from time to time and to offer a chance to compare results when another method is applied.

### Principle of the Method

The substance is placed in a test vessel which is progressively heated until the vapor reaches a sufficiently high concentration in air to produce a flammable mixture which can be ignited.

### Quality Criteria

**Repeatability**—The repeatability varies according to flash point range and the test method used; maximum is  $\pm 2^\circ\text{C}$ .

**Sensitivity**—The sensitivity depends on the test method used.

**Specificity**—The specificity of some test methods is limited to certain flash point ranges and subject to substance-related data (e.g. high viscosity).

### Description of the Method

**Preparations**—A sample of the test substance is placed in a test apparatus according to specific method used.

**Test Conditions**—The apparatus is preferably placed in a draft free position.

**Performance of the Test**—*Equilibrium method* (see ISO 1516, ISO 3680, ISO 1523, ISO 3679).

### Nonequilibrium Method

Abel Apparatus (see BS 2000 part 170, NF M07-011, NF T66-009).

Abel-Pensky Apparatus (see (EN 57), DIN 51755 part I (for temperature from 5 to 65°C), DIN 51755 part 2 (for temperature below 5°C), NF M07-036).

*Tag Apparatus* (see ASTM D 56).

*Pensky-Martens Apparatus* (see ISO 2719, (EN 11), DIN 51758, ASTM D 93, BS 2000-34, NF M07-019).

**Remarks**—When the flash point, determined by a non-equilibrium method is found to be  $0 \pm 2^\circ\text{C}$ ,  $21 \pm 2^\circ\text{C}$ ,  $55 \pm 2^\circ\text{C}$ , it should be confirmed by an equilibrium method using the same apparatus.

Only the methods which can give the temperature of the flash point may be used for a notification.

To determine the flash point of viscous liquids (paints, gums and similar) containing solvents, only apparatus and test methods suitable for determining the flash point of viscous liquids may be used.

See ISO 3679, ISO 3680, ISO 1523, DIN 53213 part 1.

### Other Related Flammability Methods

The following flammability methods related to flash point are listed in Annex V, Part A, by their part number and title: flammability (solids); flammability (gases); flammability (substances and preparations which, in contact with water or damp air, evolve highly flammable gases in dangerous quantities); flammability (solids and liquids); explosive properties; autoflammability (determination of the temperature of self-ignition of volatile liquids and of gases); and oxidizing properties.

## 6. THE INTERNATIONAL AIR TRANSPORT ASSOCIATION (IATA), IATA BUILDING, 200 PEEL ST., MONTREAL, QUEBEC, CANADA H3A 2R4.

IATA is not an international regulatory agency like the others listed in this chapter. Whereas, they have regulations that are binding on contracting nations, IATA's regulations are binding only on its member airlines. This association is included in this chapter because its regulations are identical to the United Nations Recommendations of the Committee of Experts on the Transportation of Dangerous Goods and to other organizations listed in this chapter.

IATA is an organization of 139 airlines worldwide. Over the years, IATA has pioneered the development of most of the standard operating practices in use today which enable passengers and cargo to move by air safely and efficiently the world over. Whereas, IATA is an association of commercial airlines, ICAO, for example is a branch of the United Nations and is composed of 152 contracting nations. The regulations issued by IATA are thus binding only on IATA Member airlines. On the other hand, regulations issued by ICAO are binding on its contracting nations and, therefore, on the airlines of those nations.

IATA does not develop laboratory procedures for such tests as flash point determination, but makes use of standard test methods already developed. The IATA Dangerous Goods Regulations (DGR) use the flash point as a criteria in classifying flammable liquids.

The IATA Dangerous Goods Regulations fully comply with the ICAO Technical Instructions for the Safe Transport of Dangerous Goods by Air and the U.N.'s "Orange Book." These instructions are reprinted in Section 1 of this chapter.

However, the DGR also includes airline standard practices and reference material not found in these publications. Readers are directed to contact IATA directly for the latest revisions of these materials.

# **Appendices**

# Appendix A

## Regulatory and Non-Regulatory Agencies (Governmental and Civilian)

### A.1 U.S. GOVERNMENTAL REGULATORY AGENCIES

#### Consumer Product Safety Commission (CPSC)

*Executive Offices*  
1111 18th St., NW  
Washington, DC 20207

#### *Staff Offices*

5401 Westboard Ave.  
Bethesda, MD 20207

#### Environmental Protection Agency

401 M. St., SW  
Washington, DC 20460

#### U.S. Department of Labor (DOL)

Occupational Safety & Health Administration (OSHA)  
200 Constitution Ave., NW  
Washington, DC 20210

#### U.S. Department of Transportation (DOT)

U.S. Coast Guard  
2100 Second St., SW  
Washington, DC 20593

#### Federal Aviation Administration (FAA)

Federal Office Bldg.  
800 Independence Ave., SW  
Washington, DC 20591

#### Federal Highway Administration (FHWA)

400 Seventh St., SW  
Washington, DC 20590

#### Federal Railroad Administration (FRA)

400 Seventh St., SW  
Washington, DC 20590

#### Research and Special Programs Administration (RSPA) Office of Hazardous Materials Transportation (OHMT)

400 Seventh St., SW  
Washington, DC 20590

### A.2 U.S. GOVERNMENTAL NON-REGULATORY AGENCIES

#### Federal Emergency Management Agency

Fire Administration  
National Training Center  
16825 S. Seton Ave.  
Emmitsburg, MD 21727

#### National Institute of Standards and Technology (NIST)

Route I-270 and Quince Orchard Rd.  
Gaithersburg, MD

#### *Mailing Address*

Washington, DC 20234

#### National Institute for Occupational Safety and Health (NIOSH)

5600 Fishers Lane  
Rockwell, MD 20852

#### National Transportation Safety Board (NTSB)

800 Independence Ave., SW  
Washington, DC 20594

### A.3 INTERNATIONAL GOVERNMENTAL REGULATORY ORGANIZATIONS

#### International Civil Aviation Organization (ICAO)

1000 Sherbrooke St., West  
Montreal, Quebec  
Canada H3A 2R2

#### International Maritime Organization (IMO)

101-104 Piccadilly  
London, W1V 0AE England

### A.4 UNITED NATIONS ORGANIZATIONS OF EXPERTS ON THE TRANSPORTATION OF DANGEROUS GOODS

United Nations  
New York, NY 10017

#### Economic Commission for Europe (ECE)

Palais des Nations  
CH-1211 Geneva 10  
Switzerland

**Department of Transport Convention Concerning International Carriage by Rail (COTIF)**

Regulations Concerning the International Carriage of Dangerous Goods by Rail (RID)  
Department of Transport (FRH-2)  
2 Marsham St.  
London SW1 P3 EB

**Economic Commission of Europe (ECE)**

Palais des Nations  
CH-1211 Geneve 10  
Switzerland

**Inland Transport Committee**

**European Agreement Concerning the International Carriage of Dangerous Goods by Road (ADR)**

Economic Commission for Europe (ECE)  
Palais des Nations  
CH-1211 Geneve 10  
Switzerland

**Provisions for European Inland Waterways (ADN)**

Economic Commission for Europe (ECE)  
Palais des Nations  
CH-1211 Geneve 10  
Switzerland

**Commission of the European Communities (EEC)**

Directorate-General-Environment, Civil protection and nuclear safety  
Rue de Lo Lor 200  
B-1040 Brussels  
Belgium

**A.5 INTERNATIONAL NON-GOVERNMENTAL REGULATORY ORGANIZATIONS: INTERNATIONAL AIR TRANSPORTATION ASSOCIATION (IATA)**

IATA Bldg.  
2000 Peel St.  
Montreal, Quebec,  
Canada H3A 2R4

**A.6 U.S. STATE REGULATORY AND ENFORCEMENT AGENCIES FOR HAZARDOUS MATERIALS**

All 50 states have agencies with regulatory powers concerning hazardous materials transportation. The specific agency within each state that handles hazardous materials concerns can be obtained from "Hazardous Materials Transportation, A Legislators Guide," published by the National Conference of State Legislators, 1125 17th St., Suite 1500, Denver, CO 80202.

Inquiries should be directed to the specific state agencies as follows:

**Public Service Commission**

Alabama  
Alaska  
Colorado  
Connecticut  
Indiana  
Massachusetts  
Mississippi  
Missouri  
Nebraska  
Nevada  
North Carolina  
North Dakota  
Oklahoma  
Oregon  
South Dakota  
Tennessee  
Texas  
West Virginia  
Wisconsin

**Transportation Commission/Department of Transportation**

Arkansas  
California  
Delaware  
Georgia  
Idaho  
Illinois  
Kansas  
Louisiana  
Maryland  
Minnesota  
Montana  
New Mexico  
New York  
Ohio  
Pennsylvania  
Utah  
Vermont  
Wyoming

**Department of Insurance**

Florida

**Industrial Commission**

Arizona

**Department of Environment**

Iowa

**Consumer Council**

Rhode Island

**Fire Safety Board**

Michigan



TABLE 1A

State	Part 171 General information, regulations, and definitions	Part 172 Hazardous materials table and hazardous materials communications regulations	Part 173 Shippers- general requirements for shipments and packagings
Alabama <sup>c</sup>	A	A	A
Alaska	A	A	A
Arizona	A	A	A
Arkansas <sup>c</sup>	A	A	A
California	A	A	A
Colorado	A	A	A
Connecticut	A	A	A
Delaware <sup>a</sup>	A	A	A
D.C.	D	D	D
Florida	A	A	A
Georgia	C	C	C
Hawaii	A	A	A
Idaho	A	A	A
Illinois <sup>c</sup>	A	A	A
Indiana	D	D	D
Iowa	A	A	A
Kansas	A	A	A
Kentucky	A	A	A
Louisiana	A	A	A
Maine <sup>b</sup>	C	C	C
Maryland	A	A	A
Massachusetts	A	A	A
Michigan	A	A	A
Minnesota	A	A	A
Mississippi	A	A	A
Missouri <sup>c</sup>	A	A	A
Montana	A	A	A
Nebraska	C	C	C
Nevada	A	A	A
New Hamp- shire	A	A	A
New Jersey <sup>c</sup>	C	C	C
New Mexico	A	A	A
New York	A	A	A
North Carolina	A	A	A
North Dakota	D	D	D
Ohio	A	A	A
Oklahoma	D	D	D
Oregon	A	A	A
Pennsylvania	A	A	A
Rhode Island	A	A	A
South Carolina	A	A	A
South Dakota	A	A	A
Tennessee	A	A	A
Texas	B	A	A
Utah	A	A	A
Vermont <sup>a</sup>	A	A	A
Virginia	C	C	C
Washington	A	A	A
West Virginia	D	D	D
Wisconsin	D	D	D
Wyoming <sup>d</sup>	A	A	A
Puerto Rico	D	D	D

<sup>a</sup>Applies to placarded vehicles transporting hazardous materials.

<sup>b</sup>Applicable regulations may vary with state agencies, cargo, carrier, inter-  
intrastate.

<sup>c</sup>Also applies to transporters of hazardous waste.

<sup>d</sup>Excludes intrastate private carriers.

<sup>e</sup>Excludes private carriers.

## Department of Labor and Industry

New Jersey

## State Board of Health

Virginia

## Agency Not Specified

Hawaii

Kentucky

Maine

New Hampshire

South Carolina

Washington

## A.7 STATUS OF FEDERAL HAZARDOUS MATERIALS REGULATIONS

The following information was also obtained from "Hazardous Materials Transportation, a Legislator's Guide," published by the National Conference of State Legislatures. Table 1 of CFR 49 (U.S. Department of Transportation, Use of DOT Regulations by States) lists the source for the states' use of DOT regulations as the Materials Transportation Bureau. The codes for the letters in Table 1A are as follows:

A—adopted completely; B—adopted in part; C—has similar rules; and D—has no rule.

# Appendix B

## U.S. Non-Governmental Standard, Code, and Tariff Writing Organizations

### B.1 CODE AND/OR TARIFF WRITING ORGANIZATIONS

**Airline Tariff Publishing Co. Agent**  
Dulles International Airport  
P.O. Box 17415  
Washington, DC 20041

**Association of American Railroads (AAR)**  
Hazardous Materials Systems  
1920 "L" St., NW  
Washington, DC 20036

**American Trucking Association, Inc. (ATA)**  
1616 "P" St., NW  
Washington, DC 20036

**Canadian Freight Classification**  
1162 St. Antoine St., W  
Montreal, Quebec H3C 1B5

**Coordinated Freight Classification**  
14 New England Executive Park  
Burlington, MA 01803

**National Classification Committee**  
2200 Mill Rd.  
Alexandria, VA 22314

**National Fire Protection Association (NFPA)**  
Batterymarch Park  
Quincy, MA 02269

**National Motor Freight Traffic Association**  
1616 "P" St., NW  
Washington, DC 20036

**National Tank and Truck Carriers, Inc.**  
1616 "P" St., NW  
Washington, DC 20036

**Uniform Freight Classification Committee**  
Suite 1106  
222 South Riverside Plaza  
Chicago, IL 60606

**United Parcel Service**  
UPS Hazardous Materials Guide  
National Customer Service  
Building Number 5  
51 Weaver St.  
Greenwich, CT 06830

### B.2 BUILDING CODE ORGANIZATIONS

**Building Officials and Code Administrators International, Inc., (BOCA)**  
4051 W. Flassmoor Rd.  
Country Club Hills, IL 60478

**International Conference of Building Officials (ICBO)**  
5360 South Workman Mill Rd.  
Whittier, CA 90601

**Southern Building Code Congress International (SBCC)**  
900 Montclair Rd.  
Birmingham, AL 35213

### B.3 SAFETY ORGANIZATIONS

**American Conference of Governmental Industrial Hygienist (ACGIH)**  
P.O. Box 1937  
Cincinnati, OH 45201

**Factory Mutual System (FMS)**  
1151 Boston Providence Turnpike  
Norwood, MA 02062

**Chemical Manufacturers Association (CMA)**  
"Chemtrac"  
1825 Connecticut Ave., NW  
Washington, DC 20009

**National Safety Council (NSC)**  
444 North Michigan Ave.  
Chicago, IL 60611

**Southwest Research Institute (SIR)**  
6220 Culebra Rd.  
San Antonio, TX 78284

**Underwriters Laboratories (UL)**  
333 Pfingsten Rd.  
Northbrook, IL 60062

**B.4 STANDARDS ORGANIZATIONS  
HAVING FLASH POINT STANDARDS****American National Standards Institute (ANSI)**

1430 Broadway  
New York, NY 10018

**American Boat & Yacht Council, Inc. (ABYC)**

15 East 26th St.  
Room 1603  
New York, NY 10010

**American Oil Chemists' Society (AOC)**

508 S. 6th St.  
Champaign, IL 61820

**American Association of State Highway Transport Officials  
(AASHTO)**

341 National Press Bldg.  
Washington, DC 20004

**ASTM**

1916 Race St.  
Philadelphia, PA 19103

**Chemical Specialties Manufacturers Association (CSMA)**

50 East 41st St.  
New York, NY 10017

**Essential Oil Association of U.S.A., Inc. (EOA)**

60 East 42nd St.  
New York, NY 10017

**Factory Mutual System (FMS)**

1151 Boston Providence Turnpike  
Norwood, MA 02062

**International Conference of Building Officials (ICBO)**

5360 South Workman Mill Rd.  
Whittier, CA 90601

**National Fire Protection Association (NFPA)**

Batterymarch Park  
Quincy, MA 02260

**Underwriters Laboratories (UL)**

333 Pfingsten Rd.  
Northbrook, IL 60062

# Appendix C

## National Standards Organizations of Other Countries

Since it has not been possible to obtain standards on flash point, from all countries, the following is a list of all International Organization for Standardization (ISO) member bodies, both active and corresponding members.

A member body of ISO is the national agency or organization that is most representative of standardization in that country. It follows, that only one such body for each country is accepted for ISO membership.

The majority of ISO member bodies are governmental institutions or organizations incorporated by public law. The remainder have close links with the public administration in their own countries.

A correspondent member is normally an organization in a developing country which does not yet have its own national standards body. Correspondent members do not take an active part in the technical work, but are entitled to be kept fully informed about the work of interest to them. Nearly all the present correspondent members are governmental institutions.

Included with the name of the standards member is the acronym by which the organization is generally known, such as "ANSI" for American National Standards Institute and "AFNOR" for Association Francaise de Normalisation.

### C.1 ISO MEMBERS

#### Albania (BSA)

Komiteti i Cmimeve dhe  
Standarteve  
Prane Keshillit te Ministrave  
Tirana

#### Algeria (INAPI)

Institut algerien de normalisation et de propriété  
industrielle  
5, rue Abou Hamou Moussa  
B.P. 1021—Centre de tri  
Alger

#### Argentina (IRAM)

Instituto Argentino de Racionalización de Materiales  
Chile 1192  
C. Postal 1098  
Buenos Aires

#### Australia (SAA)

Standards Association of Australia  
Standards House

80-86 Arthur St.  
North Sydney—N.S.W. 2060

#### Austria (ON)

Osterreichisches Normungsinstitut  
Heinestrasse 38  
Postfach 130  
A-1021 Wien

#### Bangladesh (BTSI)

Bangladesh Standards and Testing Institution  
116/A Tejgaon Industrial Area  
Dhaka 8

#### Belgium (IBN)

Institut belge de normalisation  
Av. de la Brabanconne, 29  
B-1040, Brussels

#### Brazil (ABNT)

Associação Brasileira de Normas Técnicas  
Av. 13 de Maio, N° 13-28° andar  
Caixa Postal 1680  
CEP: 20.003—Rio de Janeiro—RJ

#### Bulgaria (BDS)

Comite de la qualité aupres du Conseil des Ministres  
21, rue du 6 Septembre  
1000 Sofia

#### Canada (SCC)

Standards Council of Canada  
International Standardization Branch  
2000 Argentinia Road, Suite 2-401  
Mississauga, Ontario L5N 1V8

#### Chile (INN)

Instituto Nacional de Normalizacion  
Matias Cousiño 64-6° piso  
Casilla 995—Correo 1  
Santiago

#### China (CSBS)

China State Bureau of Standards  
PO Box 820  
Beijing

#### Colombia (ICONTEC)

Instituto Colombiano de Normas Técnicas  
Carrera 37 No. 52-95  
PO Box 14237  
Bogota

**Cuba (NC)**

Comité Estatal de Normalizacion  
Egido 602 entre Gloria y Apodaca  
Zona postal 2  
La Habana

**Cyprus (CYS)**

Cyprus Organization for Standards and Control of Quality,  
Ministry of Commerce and Industry  
Nicosia

**Czechoslovakia (CSN)**

Urząd pro normalizaci a měrení  
Václavské náměstí 19  
113 47 Praha 1

**Denmark (DS)**

Dansk Standardiseringsraad  
Aurehøjvej 12  
Postbox 77  
DK-2900 Hellerup

**Egypt, Arab Republic of (EOS)**

Egyptian Organization for Standardization  
2 Latin America St.  
Garden City  
Cairo

**Ethiopia (ESI)**

Ethiopian Standards Institution  
PO Box 2310  
Addis Ababa

**Finland (SFS)**

Suomen Standardisoimislitto SFS  
PO Box 205  
SF-001121 Helsinki

**France (AFNOR)**

Association française de normalisation  
Tour Europe  
Cedex 7  
92080 Paris La Defense

**Germany (DIN)**

DIN Deutsches Institut für Normung  
Burggrafenstrasse 6  
Postfach 1107  
D-1000 Berlin 30

**Ghana (GSB)**

Ghana Standards Board  
PO Box M-245  
Accra

**Greece (ELOT)**

Hellenic Organization for Standardization  
Didotou 15  
106 80 Athens

**Hungary (MSZH)**

Magyar Szabványügyi Hivatal  
1450 Budapest 9, pf. 24

**India (ISI)**

Indian Standards Institution  
Manak Bhavan  
9 Bahadur Shah Zafar Marg  
New Delhi 110002

**Indonesia (DSN)**

Dewan Standardisasi Nasional-DSN  
Standardization Council of Indonesia  
Gedung PDIN-LIPI  
Jalan Gatot Subroto  
PO Box 3123  
Jakarta 12190

**Iran (ISIRI)**

Institute of Standards and Industrial Research of Iran  
Ministry of Industries  
PO Box 11365-7594  
Tehran

**Iraq (COSQC)**

Central Organization for Standardization and Quality  
Control  
Planning Board  
PO Box 13032  
Aljadiria  
Baghdad

**Ireland (NSAI)**

National Standards Authority of Ireland  
Ballymun Road  
Dublin-9

**Israel (SII)**

Standards Institution of Israel  
42 University Street  
Tel Aviv 69977

**Italy (UNI)**

Ente Nazionale Italiano di Unificazione  
Piazza Armando Diaz 2  
I-20123 Milano

**Ivory Coast (DINT)**

Direction de la normalisation et de la technologie  
Ministère du Plan et de l'industrie  
B.P. V65  
Abidjan

**Jamaica (JBS)**

Jamaica Bureau of Standards  
6 Winchester Road  
PO Box 113  
Kingston 10

**Japan (JISC)**

Japanese Industrial Standards Committee  
c/o Standards Department  
Agency of Industrial Science and Technology  
Ministry of International Trade and Industry  
1-3-1, Kasumigaseki, Chiyoda-ku  
Tokyo 100

**Kenya (KEBS)**

Kenya Bureau of Standards  
Off Mombasa Road  
Behind Belle Vue Cinema  
PO Box 54974  
Nairobi

**Korea, Democratic Peoples Republic of (CSK)**

Committee for Standardization of the Democratic People's  
Republic of Korea  
Taesong guyok Ryongnam dong  
Pyongyang

**Korea, Republic of (KBS)**

Bureau of Standards, Industrial Advancement  
Administration  
2, Chungang-dong Kwachon-myon  
Kyonggi-Do 171-11

**Libyan Arab Jamahiriya (LYSSO)**

Libyan Standards and Patent Section  
Industrial Research Center  
PO Box 3633  
Tripoli

**Malaysia (SIRIM)**

Standards and Industrial Research Institute of Malaysia  
PO Box 35  
Shah Alam  
Selangor

**Mexico (DGN)**

Dirección General de Normas  
Calle Puente de Tecamachalco N°. 6  
Lomas de Tecamachalco  
Sección Fuentes  
Naucalpan de Juárez 53 950

**Mongolia (MSC)**

State Committee for Prices and Standards of the Mongolian  
People's Republic  
Ulan Bator

**Netherlands (NNI)**

Nederlands Normalisatie-Instituut  
Kalfjeslaan 2  
PO Box 5059  
2600 GB Delft

**New Zealand (SANZ)**

Standards Association of New Zealand  
Private Bag  
Wellington

**Nigeria (SON)**

Standards Organisation of Nigeria  
Federal Ministry of Industries  
4 Club Road  
P.M.B. 01323  
Enugu

**Norway (NSF)**

Norges Standardiseringsforbund  
Postboks 7020 Homansbyen  
N-0306 Oslo 3

**Pakistan (PSI)**

Pakistan Standards Institution  
39 Garden Road, Saddar  
Karachi-3

**Papua New Guinea (PNGS)**

National Standards Council  
PO Box 3042  
Boroko

**Peru (ITINTEC)**

Instituto de Investigación  
Tecnológica Industrial y de Normas Técnicas  
Av. Guardia Civil 400  
Distrito San Borja  
Lima 34

**Philippines (PSA)**

Product Standards Agency  
Ministry of Trade and Industry  
361 Sen Gil J. Puyat Avenue  
Makati  
Metro Manila 3117

**Poland (PKNMIJ)**

Polish Committee for Standardization, Measures and  
Quality Control  
Ul. Elektoraina 2  
00-139 Warszawa

**Portugal (DGQ)**

Direcção-Geral da Qualidade  
Rua José Estêvão, 83-A  
1199 Lisboa Codex

**Romania (IRS)**

Institut roumain de normalisation  
Rue Ilie Pintilie 5  
Bucarest 1

**Saudi Arabia (SASO)**

Saudi Arabian Standards Organization  
PO Box 3437  
Riyadh-11471

**Singapore (SISIR)**

Singapore Institute of Standards and Industrial Research  
Maxwell Road  
PO Box 2611  
Singapore 9046

**South Africa, Republic of (SABS)**

South African Bureau of Standards  
Private Bag X 191  
Pretoria 0001

**Spain (IRANOR)**

Instituto Español de Normalización  
Calle Fernandez de la Hoz, 52  
28010 Madrid

**Sri Lanka (SLSI)**

Sri Lanka Standards Institution  
53 Dharmapala Mawatha  
PO Box 17  
Colombo 3

**Sudan (SSD)**

Sudanese Standards Department  
Ministry of Industry  
PO Box 2184  
Khartoum

**Sweden (SIS)**

SIS—Standardiserings-kommissionen i Sverige  
Tegnérsgatan 11  
Box 3 295  
S-103 66 Stockholm

**Switzerland (SNV)**

Swiss Association for Standardization  
Kirchenweg 4 Postfach  
8032 Zurich

**Syria (SASMO)**

Syrian Arab Organization for Standardization and  
Metrology  
PO Box 11836  
Damascus

**Tanzania (TBS)**

Tanzania Bureau of Standards  
PO Box 9524  
Dar Es Salaam

**Thailand (TISI)**

Thai Industrial Standards Institute  
Ministry of Industry  
Rama VI Street  
Bangkok 10400

**Trinidad and Tobago (TTBS)**

Trinidad and Tobago Bureau of Standards  
Century Drive  
Trincity Industrial Estate  
Tunapuna  
PO Box 467  
Port of Spain

**Tunisia (INNORPI)**

Institut national de la normalisation et de la propriété  
industrielle  
B.P. 23  
1012 Tunis-Belvédère

**Turkey (TSE)**

Türk Standardlari Enstitüsü  
Necatibey Cad. 112

**Bakanliklar**

Ankara

**United Kingdom (BSI)**

British Standards Institution  
2 Park Street  
London W1A 2BS

**USSR (GOST)**

USSR State Committee for Standards  
Leninsky Prospekt 9  
Moskva 117049

**Venezuela (COVENIN)**

Comision Venezolana de Normas Industriales  
Avda. Andrés Bello  
Edif. Torre Fondo Común  
Piso 11  
Caracas 1050

**Viet Nam, Socialist Republic of (TCVN)**

Direction générale de Standardisation, de métrologie et de  
contrôle de la qualité  
70, Box 81, rue Tran Hung Dao  
Hanoi

**Yugoslavia (SZS)**

Savezni zavod za standardizaciju  
Slobodana Penezica-Krcuna br. 35  
Post. Pregr, 933  
11000 Beograd

**Zambia (ZABS)**

Zambia Bureau of Standards  
National Housing Authority Building  
PO Box 50259  
Lusaka

**C.2 ISO CORRESPONDENT MEMBERS****Bahrain**

Ministry of Commerce and Agriculture  
PO Box 5479  
Bahrain

**Barbados**

Barbados National Standards Institution (BNSI)  
"Flodden" Culloden Road  
St. Michael

**Cameroon**

Service de la normalisation  
Direction de l'industrie  
Ministere de l'Economie et du plan  
B.P. 1604  
Yaounde

**Ecuador**

Instituto Ecuatoriano de Normalizacion  
Casilla 3999  
A. Baguerizo Moreno 454  
Quito

**168 FLASH POINT STANDARDS AND THEIR USE**

**Hong Kong**

Hong Kong Standards and Testing Center  
10 Dai Wang Street  
Taipo Industrial Estate  
Taipo, N.T.  
Hong Kong

**Iceland**

Technological Institute of Iceland  
Division of Standards  
Keldnaholt  
IS-110 Reykjavik

**Jordan**

Directorate of Standards  
Ministry of Industry and Trade  
PO Box 2019  
Amman

**Kuwait**

Standards and Metrology Department  
Ministry of Commerce and Industry  
PO Box 2944  
Kuwait

**Lebanon**

Lebanese Standards Institution  
PO Box 19-5144  
Beirut

**Malawi**

Malawi Bureau of Standards  
PO Box 946  
Blantyre

**Mauritius**

Mauritius Standards Bureau.  
Ministry of Industry  
Reduit

**Mozambique (CEDIMO)**

National Documentation and Information Centre of  
Mozambique  
PO Box 4116  
Maputo

**Oman**

Directorate General for Specifications and Measurements  
Ministry of Commerce and Industry  
PO Box 550  
Muscat

**Togo**

Conseil supérieur de normalisation  
Ministère du plan et de l'industrie  
B.P. 831  
Lome

**United Arab Emirates**

Directorate of Standardization and Metrology  
PO Box 433  
Abu Dhabi

**Uruguay**

Instituto Uruguayo de Normas Técnicas  
San Jose 1031 P.7  
Montevideo





HARRY A. WRAY

## ABOUT THE EDITOR

Currently retired from the E.I. du Pont de Nemours and Company, Inc., Harry A. Wray served there for 29 years. Part of his early career was spent as a research chemist in industrial finishes prior to his work with standards and test methods. Before joining the Dupont Co., Wray spent 10 years teaching at Lewistown, PA High School, Long Island University, and for Pennsylvania State University. The editor holds a B.S. degree in Science from Albright College and a Masters Degree in Chemistry from Columbia University.

While with Dupont, Mr. Wray became interested in flash point testing and Government regulations based on these tests. He has published several articles on flash point testing and contributed to the development of several related ASTM standards. Wray has served on many ASTM committees including, Committee D-1 on Paint and Related Coatings, D-2 on Petroleum Products and Lubricants, E-27 on Hazard Potential of Chemicals, E-43 on Metric Practices and the ASTM Standing Committee on Terminology.

Mr. Wray was one of the founders and the first chairman of the ASTM Coordinating Committee on Flash Point and Related Properties. He is now *Chairman Emeritus* of the committee.

During Wray's long membership with ASTM he has been honored with many awards including; Honorary Member of D-1, the Committee on Terminology Membership Award, and their Certificate of Appreciation, the Henry A. Gardner Award, the William T. Pearce Award, and ASTM's Award of Merit. Wray has also been awarded the U.S. Environmental Protection Agency's National Enforcement Investigations Center Certificate of Appreciation.

Wray, with the help of his local Congressman, was able to convince congress to amend the Federal Hazardous Substances Act to permit the Consumer Product Safety Commission to adopt flammability regulations similar to other agencies.

Now retired, Mr. Wray continues to work with flammability of liquids as a consultant and expert witness.

ISBN 0-8031-1410-4