



# Standard Guide for Online Monitoring of Corrosion in Plant Equipment (Electrical and Electrochemical Methods)<sup>1</sup>

This standard is issued under the fixed designation G96; the number immediately following the designation indicates the year of original adoption or, in the case of revision, the year of last revision. A number in parentheses indicates the year of last reapproval. A superscript epsilon (ε) indicates an editorial change since the last revision or reapproval.

## 1. Scope

1.1 This guide covers the procedure for conducting online corrosion monitoring of metals in plant equipment under operating conditions by the use of electrical or electrochemical methods. Within the limitations described, these test methods can be used to determine cumulative metal loss or instantaneous corrosion rate, intermittently or on a continuous basis, without removal of the monitoring probes from the plant.

1.2 The following test methods are included: Test Method A for electrical resistance, and Test Method B for polarization resistance.

1.2.1 Test Method A provides information on cumulative metal loss, and corrosion rate is inferred. This test method responds to the remaining metal thickness except as described in Section 5.

1.2.2 Test Method B is based on electrochemical measurements for determination of instantaneous corrosion rate but may require calibration with other techniques to obtain true corrosion rates. Its primary value is the rapid detection of changes in the corrosion rate that may be indicative of undesirable changes in the process environment.

1.3 The values stated in SI units are to be considered standard. The values in parentheses are for information only.

1.4 *This standard does not purport to address all of the safety concerns, if any, associated with its use. It is the responsibility of the user of this standard to establish appropriate safety and health practices and determine the applicability of regulatory limitations prior to use.* Specific precautionary statements are given in 5.6.

## 2. Referenced Documents

### 2.1 ASTM Standards:<sup>2</sup>

<sup>1</sup> This guide is under the jurisdiction of ASTM Committee G01 on Corrosion of Metals and is the direct responsibility of ASTM Subcommittee G01.11 on Electrochemical Measurements in Corrosion Testing.

Current edition approved Aug. 1, 2013. Published August 2013. Originally approved in 1990. Last previous edition approved in 2008 as G96–90 (2008). DOI: 10.1520/G0096-90R13.

<sup>2</sup> For referenced ASTM standards, visit the ASTM website, www.astm.org, or contact ASTM Customer Service at service@astm.org. For *Annual Book of ASTM Standards* volume information, refer to the standard's Document Summary page on the ASTM website.

- D1125 Test Methods for Electrical Conductivity and Resistivity of Water
- G1 Practice for Preparing, Cleaning, and Evaluating Corrosion Test Specimens
- G3 Practice for Conventions Applicable to Electrochemical Measurements in Corrosion Testing
- G4 Guide for Conducting Corrosion Tests in Field Applications
- G15 Terminology Relating to Corrosion and Corrosion Testing (Withdrawn 2010)<sup>3</sup>
- G59 Test Method for Conducting Potentiodynamic Polarization Resistance Measurements
- G102 Practice for Calculation of Corrosion Rates and Related Information from Electrochemical Measurements

## 3. Terminology

3.1 *Definitions*—See Terminology G15 for definitions of terms used in this guide.

## 4. Summary of Guide

4.1 *Test Method A—Electrical Resistance*—The electrical resistance test method operates on the principle that the electrical resistance of a measuring element (wire, strip, or tube of metal) increases as its cross-sectional area decreases:

$$R = \sigma \frac{l}{A} \quad (1)$$

where:

- R = resistance,
- σ = resistivity of metal (temperature dependent),
- l = length, and
- A = cross-section area.

In practice, the resistance ratio between the measuring element exposed to corrosion and the resistance of a similar reference element protected from corrosion is measured, to compensate for resistivity changes due to temperature. Based on the initial cross-sectional area of the measurement element, the cumulative metal loss at the time of reading is determined. Metal loss measurements are taken periodically and manually

<sup>3</sup> The last approved version of this historical standard is referenced on www.astm.org.

or automatically recorded against a time base. The slope of the curve of metal loss against time at any point is the correction rate at that point. The more frequently measurements are taken, the better is the resolution of the curve from which the corrosion rate is derived.

4.1.1 The electrical resistance of the metal elements being measured is very low (typically 2 to 10 mΩ). Consequently, special measurement techniques and cables are required to minimize the effect of cable resistance and electrical noise.

4.1.2 Various probe element cross-sectional areas are necessary so that a wide range of corrosion rates can be monitored with acceptable resolution.

**4.2 Test Method B—Polarization Resistance:**

4.2.1 The polarization resistance test method involves interaction with the electrochemical corrosion mechanism of metals in electrolytes in order to measure the instantaneous corrosion rate. Its particular advantage is its speed of response to corrosion rate upsets. On a corroding electrode subject to certain qualifications (see 12.1), it has been shown that the current density associated with a small polarization of the electrode is directly proportional to the corrosion rate of the electrode.

4.2.2 The polarization resistance equation is derived in Test Method G59. See Practice G3 for applicable conventions. For small polarization of the electrode (typically ΔE up to 20 mV), the corrosion current density is defined as:

$$i_{corr} = \frac{B}{R_p} \tag{2}$$

where:

- B = a combination of the anodic and cathodic Tafel slopes ( $b_a$ ,  $b_c$ ), and
- $R_p$  = the polarization resistance with dimensions ohm-cm<sup>2</sup>.

$$B = \frac{b_a b_c}{2.303 (b_a + b_c)} \tag{3}$$

4.2.3 The corrosion current density,  $i_{corr}$ , can be converted to corrosion rate of the electrode by Faraday’s law if the equivalent weight (EW) and density, ρ, of the corroding metal are known (see Practice G102):

$$\text{corrosion rate} = K_1 \frac{i_{corr}}{\rho} EW \tag{4}$$

where:

$K_1$  = a constant.

4.2.4 Equivalent weight of an element is the molecular weight divided by the valency of the reaction (that is, the number of electrons involved in the electrochemical reaction).

4.2.5 In order to obtain an alloy equivalent weight that is in proportion with the mass fraction of the elements present and their valence, it must be assumed that the oxidation process is uniform and does not occur selectively; that is, each element of the alloy corrodes as it would if it were the only element present. In some situations these assumptions are not valid.

4.2.6 Effective equivalent weight of an alloy is as follows:

$$\frac{1}{\sum_{i=1}^m \frac{n_i f_i}{W_i}} \tag{5}$$

where:

- $f_i$  = mass fraction of  $i_{th}$  element in the alloy,
- $W_i$  = atomic weight of the  $i_{th}$  element in the alloy,
- $n_i$  = exhibited valence of the  $i_{th}$  element under the conditions of the corrosion process, and
- $m$  = number of component elements in the alloy (normally only elements above 1 mass % in the alloy are considered).

Alloy equivalent weights have been calculated for many engineering metals and alloys and are tabulated in Practice G102.

4.2.7 Fig. 1 represents an equivalent circuit of polarization resistance probe electrodes in a corroding environment. The value of the double layer capacitance,  $C_{dl}$ , determines the charging time before the current density reaches a constant value,  $i$ , when a small potential is applied between the test and auxiliary electrode. In practice, this can vary from a few seconds up to hours. When determining the polarization resistance,  $R_p$ , correction or compensation for solution resistance,  $R_s$ , is important when  $R_s$  becomes significant compared to  $R_p$ . Test Methods D1125 describes test methods for electrical conductivity and resistivity of water.

4.2.8 Two-electrode probes, and three-electrode probes with the reference electrode equidistant from the test and auxiliary electrode, do not correct for effects of solution resistance,

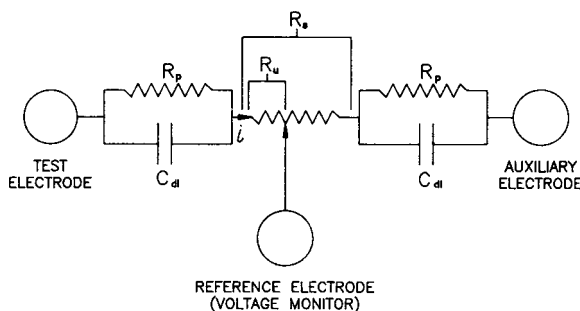

NOTE 1— $R_s$  = Solution Resistance (ohm-cm<sup>-2</sup>) between test and auxiliary electrodes (increases with electrode spacing and solution resistivity).  
 $R_u$  = Uncompensated component of solution resistance (between test and reference electrodes) (ohm-cm<sup>-2</sup>).  
 $R_p$  = Polarization Resistance  $R_p$  (ohm-cm<sup>2</sup>).  
 $C_{dl}$  = Double layer capacitance of liquid/metal interface.  
 $i$  = Corrosion current density.

**FIG. 1 Equivalent Circuit of Polarization Resistance Probe**

without special electronic solution resistance compensation. With high to moderate conductivity environments, this effect of solution resistance is not normally significant (see Fig. 2).

4.2.9 Three-electrode probes compensate for the solution resistance,  $R_s$ , by varying degrees depending on the position and proximity of the reference electrode to the test electrode. With a close-spaced reference electrode, the effects of  $R_s$  can be reduced up to approximately ten fold. This extends the operating range over which adequate determination of the polarization resistance can be made (see Fig. 2).

4.2.10 A two-electrode probe with electrochemical impedance measurement technique at high frequency short circuits the double layer capacitance,  $C_{dl}$ , so that a measurement of solution resistance,  $R_s$ , can be made for application as a correction. This also extends the operating range over which adequate determination of polarization resistance can be made (see Fig. 2).

4.2.11 Even with solution resistance compensation, there is a practical limit to the correction (see Fig. 2). At higher solution resistivities the polarization resistance technique cannot be used, but the electrical resistance technique may be used.

4.2.12 Other methods of compensating for the effects of solution resistance, such as current interruption, electrochemical impedance and positive feedback have so far generally been confined to controlled laboratory tests.

5. Significance and Use

5.1 General corrosion is characterized by areas of greater or lesser attack, throughout the plant, at a particular location, or even on a particular probe. Therefore, the estimation of corrosion rate as with mass loss coupons involves an averaging across the surface of the probe. Allowance must be made for the fact that areas of greater or lesser penetration usually exist

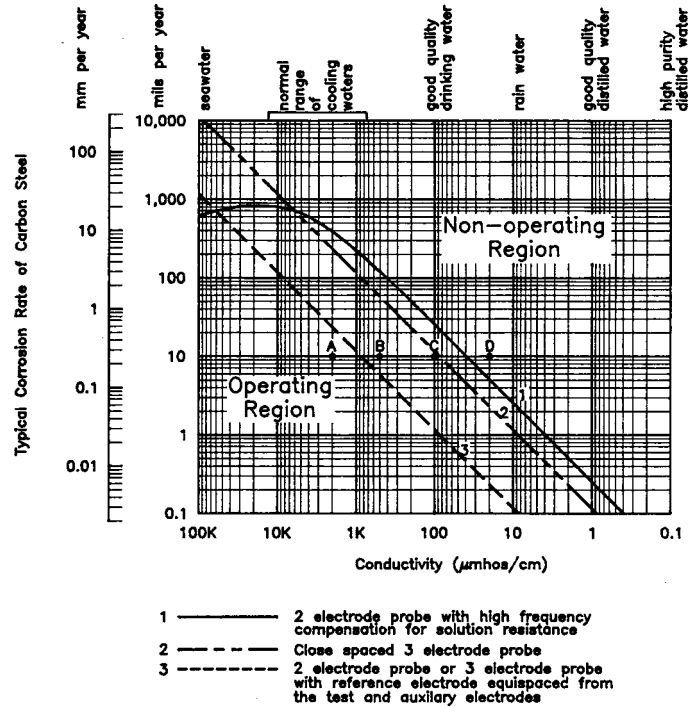

NOTE 1—See Appendix X1 for derivation of curves and Table X1.1 for description of points A, B, C and D.

NOTE 2—Operating limits are based on 20 % error in measurement of polarization resistance equivalent circuit (see Fig. 1).

NOTE 3—In the Stern-Geary equations, an empirical value of  $B = 27.5$  mV has been used on the ordinate axis of the graph for “typical corrosion rate of carbon steel”.

NOTE 4—Conductivity  $\frac{(\mu\text{mhos})}{\text{cm}} = \frac{1\,000\,000}{\text{Resistivity (ohm-cm)}}$

NOTE 5—Effects of solution resistance are based on a probe geometry with cylindrical test and auxiliary electrodes of 4.75 mm (0.187 in.) diameter, 31.7 mm (1.25 ft) long with their axes spaced 9.53 mm (0.375 in.) apart. Empirical data shows that solution resistance (ohms-cm<sup>2</sup>) for this geometry = 0.55 × resistivity (ohms-cm<sup>2</sup>).

NOTE 6—A two-electrode probe, or three-electrode probe with the reference electrode equidistant from the test and auxiliary electrode, includes % of solution resistance between working and auxiliary electrodes in its measurement of  $R_p$ .

NOTE 7—A close-space reference electrode on a three electrode probe is assumed to be one that measures 5 % of solution resistance.

NOTE 8—In the method for Curve 1, basic polarization resistance measurement determines  $2R_p + R_s$  (see Fig. 1). High frequency measurement short circuits  $C_{dl}$  to measure  $R_s$ . By subtraction polarization resistance,  $R_p$  is determined. The curve is based on high frequency measurement at 834 Hz with  $C_{dl}$  of 40 μ F/cm<sup>2</sup> on above electrodes and ± 1.5 % accuracy of each of the two measurements.

NOTE 9—Curve 1 is limited at high conductivity to approximately 700 mpy by error due to impedance of  $C_{dl}$  at frequency 834 Hz. At low conductivity it is limited by the error in subtraction of two measurements where difference is small and the measurements large.

NOTE 10—Errors increase rapidly beyond the 20 % error line (see Appendix X1, Table X1.1).

FIG. 2 Guidelines on Operating Range for Polarization Resistance

on the surface. Visual inspection of the probe element, coupon, or electrode is required to determine the degree of interference in the measurement caused by such variability. This variability is less critical where relative changes in corrosion rate are to be detected.

5.2 Both electrical test methods described in this guide provide a technique for determining corrosion rates without the need to physically enter the system to withdraw coupons as required by the methods described in Guide G4.

5.3 Test Method B has the additional advantage of providing corrosion rate measurement within minutes.

5.4 These techniques are useful in systems where process upsets or other problems can create corrosive conditions. An early warning of corrosive attack can permit remedial action before significant damage occurs to process equipment.

5.5 These techniques are also useful where inhibitor additions are used to control the corrosion of equipment. The indication of an increasing corrosion rate can be used to signal the need for additional inhibitor.

5.6 Control of corrosion in process equipment requires a knowledge of the rate of attack on an ongoing basis. These test methods can be used to provide such information in digital format easily transferred to computers for analysis.

## TEST METHOD A—ELECTRICAL RESISTANCE (1-6)<sup>4</sup>

### 6. Limitations and Interferences

6.1 Results are representative for average metal loss on the probe element. On wire-form measuring elements, pitting may be indicated by rapid increases in metal loss reading after 50 % of probe life is passed. The larger cylindrical measuring elements are much less sensitive to the effect of pitting attack. Where pitting is the only form of attack, probes may yield unreliable results.

6.2 It should be recognized that the thermal noise and stress-induced noise on probe elements, and electrical noise on these systems, occur in varying degrees due to the process and local environment. Care should be exercised in the choice of the system to minimize these effects. Electrical noise can be minimized by use of correct cabling, and careful location of equipment and cable runs (where applicable) to avoid electrically noisy sources such as power cables, heavy duty motors, switchgear, and radio transmitters.

6.2.1 The electrical resistivity of metals increases with increased temperature. Although basic temperature compensation is obtained by measuring the resistance ratio of an exposed test element and protected reference element, the exposed element will respond more rapidly to a change in temperature than does the protected reference element. This is a form of thermal noise. Various probes have different sensitivities to such thermal noise. Where temperature fluctuations may be significant, preference should be given to probes with the lowest thermal noise sensitivity.

6.2.2 If probe elements are flexed due to excessive flow conditions, a strain gage effect can be produced introducing stress noise onto the probe measurement. Suitable probe element shielding can remove such effects.

6.3 Process fluids, except liquid metals and certain molten salts, do not normally have sufficient electrical conductivity to produce a significant shorting effect on the electrical resistance of the exposed probe element. Conductive deposits (such as iron sulfide) can cause some short-circuiting effect on the element, reducing the measured metal loss, or showing some apparent metal gain. Certain probe configurations are less sensitive to this than others, depending on the path length between one end of the exposed probe element and the other.

6.4 When first introduced into a system, initial transient corrosion rates on a probe element may be different from the longer term corrosion rates.

6.4.1 Establishment of a probe element surface typical of the plant by passivation, oxidation, deposits, or inhibitor film build up may vary from hours to several days.

6.5 Since the corrosion rate is usually temperature dependent, results will be comparable only for the alloy at the process temperature to which the probes are exposed. In heat transfer environments actual plant metal temperatures may be significantly different from that of the test probe.

6.6 Electrical resistance probe elements are by their nature consumable. Hazardous situations may occur if probes are left in service for extended periods beyond their probe life. Crevice corrosion can cause damage or leaks at the element in some specimen configurations, that can cause false readings and early failure of probe elements. Normally the probe life is limited to approximately 50 % of the probe element thickness for safety reasons. Additionally, beyond this point measurements become increasingly erratic due to the irregular corroded surface of the probe element, and the particularly non-linear characteristics of wire probe elements.

6.6.1 Electrical resistance probes should be selected to provide a suitable backup seal, that is compatible with the process environment, in order to contain the process if the element seal fails.

### 7. Apparatus

#### 7.1 *Electrical Resistance Corrosion Probes:*

7.1.1 A probe is composed of two elements of identical material. One is a measuring element and the other is a protected reference element. In addition, a further check element is fully incorporated beyond the reference element to assist in monitoring of any process leakage into the probe.

7.1.2 Process monitoring probes are available in both retractable and non-retractable configurations. The former enables removal of the probe for inspection or probe replacement under operating conditions, except where operational safety precludes this.

7.1.3 There is a trade off between probe sensitivity and probe life. Care should be taken in selecting a probe sufficiently sensitive for the corrosion conditions, particularly when monitoring for process upsets.

<sup>4</sup> The boldface numbers in parentheses refer to a list of references at the end of this standard.



7.1.4 Systems typically have a resolution of 0.1 % of probe life. However, for reasons of noise given in 6.2, it is generally recommended that only changes of greater than 1 % of probe life are used for calculation of a corrosion rate or detection of an upset. When monitoring steady metal loss rather than process upsets, probe life is generally more critical than response time. For example, a typical probe span suitable for a six month probe life would have on average a 1 % change approximately every two days.

7.1.5 For process upset detection, response time to the upset is much more critical than probe life. A probe sensitivity should be chosen such that 1 % of the probe life, at the upset corrosion rate, corresponds to the desired or maximum permissible response time to the upset condition. This generally will demand a more sensitive probe. However, since the upset condition will generally not exist for an extended period, the probe life will not be severely reduced.

7.1.6 Check compatibility of process fluid with probe materials and seals.

### 7.2 *Electrical Resistance Probe Monitoring Instruments:*

7.2.1 Portable, intermittent instruments, and continuous single and multi-channel instruments are available. Since the electrical resistance probe measures cumulative metal loss, the intermittent measurement permits the determination of the average corrosion rate only between the measurement points. With continuous monitoring, corrosion in real time can be determined.

7.2.2 Automatic continuous monitoring systems may be standalone systems or interfaced to other process computers, or both.

## 8. Probe Preparation

8.1 Commercial probes are generally received in sealed plastic bags to protect prepared surfaces. Care should be taken during installation to avoid handling the probe measurement element, that can cause additional corrosion.

8.2 Probe measurement element surfaces should be smooth and free of indentations or signs of mechanical damage. Grit-blasting with 120 grit is suitable as a surface preparation prior to degreasing.

8.3 If probes are being moved from one system to another, they must be cleaned mechanically before reuse to ensure complete removal of oxide or inhibitor films. Degreasing is necessary to complete the cleaning procedure. Practice G1 provides guidance on proper methods of cleaning various materials. Some people do not recommend reusing the probes.

8.4 Mechanical or chemical cleaning will remove metal from the probe measurement element, increasing its reading. This new reading should be taken immediately after installation in the new location.

## 9. Probe Installation

9.1 Install the probe in a position as representative of the corrosive environment as possible without causing deleterious effects to the probe or the system. Do not mount probe transversely in a high-flow pipeline without shielding (see 6.3).

9.2 Do not install the probe in a dead-end section where temperature or flow conditions, or both, are not representative of the system under examination.

## 10. Procedure

### 10.1 *Portable Intermittent Instrument:*

10.1.1 Check correct operation of the instrument with the test probe provided according to the manufacturer's instructions.

10.1.2 Connect the instrument to the probe and log both the measure and check readings. Ensure that the check reading is within specified limits. Follow the manufacturer's instructions to convert the measured reading to cumulative metal loss. Check that the readings are steady and record the midpoint and extent of any variation of the reading.

### 10.2 *Automatic Continuous Monitoring Instruments:*

10.2.1 These instruments are available in various single or multi-channel configurations. They may be standalone systems or interfaced with process computers, or both. These units provide continuous information on metal loss or corrosion rates, or both.

10.2.2 The system should be installed and tested according to the manufacturer's instructions. Test probes are normally provided to assist the set-up of all channels and cabling of the system.

10.2.3 Connect the operational probes into the system.

10.2.4 Various output forms of information are available, together with alarms. Computerized systems will often allow alarms to be set for excessive corrosion rates to draw attention to problem areas that may then be analyzed in detail from the metal loss versus time graph. Generally the most useful form of data is the graph of metal loss versus time for each monitored point.

## 11. Interpretation of Results

11.1 Plot the graph of metal loss versus time. Upsets and changes in corrosion rate will be readily observable as changes in the slope of the curve. The average corrosion rate will be the slope of the line connecting the two points on the curve over the time period under consideration. The maximum corrosion rate will be the slope of the tangent to the curve at the steepest point of the curve (see Fig. 3).

11.2 Some systems automatically calculate corrosion rates over various periods.

11.3 Careful interpretation is necessary in correlating these corrosion test results with actual metal corrosion in the plant. Comparison with metal coupon results (see Guide G4) or with actual metal exposed in the plant is recommended.

11.3.1 Actual mass loss incurred by the probe elements can be used to establish correlations between the corrosion rate estimated by the electrical resistance methods and actual corrosion losses. Practice G1 provides guidance on methods of evaluating mass loss.

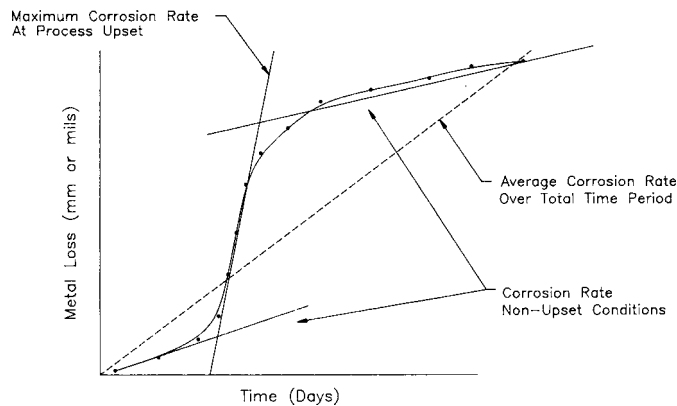

FIG. 3 Typical Plot of Metal Loss Versus Time

## TEST METHOD B—POLARIZATION RESISTANCE (2, 3, 4, and 6-25)

### 12. Limitations and Interferences

12.1 In the case of polarization resistance measurements, interferences derive from both theoretical and practical assumptions and limitations.

12.1.1 The theoretical polarization resistance equations in 4.2.2 on which the measurement is based are derived on the following assumptions: (2, 19)

12.1.1.1 The corrosion is uniform.

12.1.1.2 The corrosion mechanism consists of only one anodic and one cathodic reaction. The corrosion potential is not near the redox potential of either reaction.

12.1.1.3 Other secondary reactions that are not directly corrosion related but involve charge transfer are not significant.

12.1.1.4 Metals or alloys should give Tafel kinetics for both anodic and cathodic reactions.

12.1.1.5 Measurements are made over a sufficiently small polarization range that the potential-current plot is essentially linear.

12.2 The polarization resistance technique is restricted to use in sufficiently conductive environments (refer to Fig. 2).

12.3 Deposits on the electrodes may affect the results.

12.4 When polarization of an electrode is made by the polarization resistance measurement, time is required to charge the double layer capacitance,  $C_{dl}$ , (see Fig. 1) before a measurement can be taken. The assumption is that the corrosion potential has remained constant through this measurement cycle. This assumption can be a limitation if long cycle times are used, particularly in a dynamic plant environment.

12.5 The theoretical polarization resistance equation in 4.2.2 relates only to the corrosion interface. In practical measurements solution resistance becomes an increasing interference in low conductivity environments.

12.5.1 A general indication of limits of use are shown in Fig. 2. (For derivation of curves in Fig. 2 and examples of errors, see Appendix X1.) The main limitations of each technique in plant equipment are as follows:

12.5.1.1 *Two-Electrode Probes and Three Electrode Probes With Equidistant Reference Electrode*—Limited as solution resistance becomes significant compared with polarization resistance.

12.5.1.2 *Three-Electrode Probe With Close-Space Reference Electrode*—Compensation for solution resistance limited by physical proximity of reference electrode to test electrode and its position in the potential field between the test and auxiliary electrode.

12.5.1.3 *High Frequency Measurement for Compensation of Solution Resistance*—Limited by error of small differences between two large numbers at high solution resistance, and the frequency of the resistance compensation measurement.

12.5.1.4 *Current Interruption for Compensation of Solution Resistance*—Limited by noise on high impedance input at time of current interruption measurement.

12.6 In actual plant measurements, fouling or bridging of electrodes with conductive deposits may reduce the apparent value of polarization resistance thereby indicating a higher corrosion rate. This will invalidate measurements until the probe is cleaned.

12.7 Probes of pitted metal or metal with sharp edges may yield unreliable results. General reuse of probe electrodes is not recommended.

12.8 Since the corrosion rate is usually temperature dependent, results will be comparable only for the alloy at the process temperature to which the probes are exposed. In heat transfer environments actual plant metal temperatures may be significantly different from that of the test probe.

12.9 The corrosion rates occurring on the probe electrodes during the first few hours or days of exposure may not be typical of corrosion occurring in the system. Establishment of a probe electrode surface typical of the plant by passivation, oxidation, deposits, or inhibitor film build up may vary from hours to several days. Pre-conditioning of electrodes to correspond to the chemical treatment of the plant may reduce this transient effect.

12.10 Corrosion rates may be affected by flow velocity. Consequently, probe electrodes should be used in a velocity

typical of the plant conditions. Caution should be exercised in any laboratory tests to reproduce typical velocities and keep the test fluid representative of plant conditions by preventing an unrepresentative build up of corrosion product in solution, or depletion of dissolved oxygen.

12.11 Where flow dynamics or process fluid separation at a pipe or vessel wall are particularly critical to the corrosion process, a flush-mounted probe may be more desirable than a probe with electrodes positioned near the center of the pipe or vessel.

12.12 It should be recognized that polarization resistance measurement only determines metal lost by corrosion and not metal lost by mechanical removal (that is, erosion). In the case of erosion corrosion, the corrosion component will be measured.

### 13. Apparatus

#### 13.1 *Polarization Resistance Corrosion Probes:*

13.1.1 A probe is composed of two or three electrodes. With a two-electrode probe, both electrodes are of the material under test. With a three-electrode probe, the test electrode is of the alloy under test. The other electrodes may or may not be of the same alloy.

13.1.2 Process monitoring probes are available in both retractable and non-retractable configurations. The former enables removal of the probe for inspection, cleaning, or electrode replacement under operating conditions except where operational safety precludes this.

#### 13.2 *Polarization Resistance Probe Monitoring Instruments:*

13.2.1 Both portable intermittent and continuous single and multi-channel instruments are available. The polarization resistance probe determines the corrosion rate only at the time of measurement. No cumulative metal loss or corrosion history is stored by the probe as with the electrical resistance technique. For this reason continuous monitoring is more critical for polarization resistance measurement in order to detect system or process upsets.

13.2.2 Automatic continuous monitoring system may be stand-alone systems or interfaced to other process computers, or both.

### 14. Probe Preparation

14.1 Commercial probes are generally received in plastic bags for protection. Working electrodes of required alloys are generally supplied separately in sealed plastic bags to protect the prepared surfaces. Probe electrodes should be kept clean during handling and installation by the use of clean gloves or clean paper to avoid causing additional corrosion. Where electrodes are screwed onto connecting pins on the probe body, take care to ensure the insulating and sealing washers are in good condition and correctly installed to prevent any galvanic corrosion between electrodes and connecting pins.

14.2 When moving probes from one system to another, it is recommended that new electrodes are installed. If electrodes are reused, they should be cleaned mechanically to remove oxide or inhibitor films. Degreasing is necessary to complete

the cleaning procedure. Practice G1 provides guidance on proper methods of cleaning various materials.

### 15. Probe Installation

15.1 Preferably install the probe directly into the plant in a position as representative of the corrosive environment as possible without causing deleterious effects to the plant, such as a major flow restriction. Do not mount probe where damage may occur from high velocities or debris.

15.2 Install the probe so that the electrodes face the flow in a similar manner. Do not position them so that one electrode shields the other electrodes from the flow.

15.3 Do not install the probe in a dead end section where temperature or flow conditions, or both, are not representative of the system under examination.

15.4 If a bypass loop is being used for containing the probe, ensure that conditions in the loop are representative of those in the actual system.

15.5 Probes should be removed at intervals to inspect for electrode deterioration, damage, or bridging of electrodes and ensure continued quality of corrosion rate data.

### 16. Procedure

#### 16.1 *Portable Intermittent Instrument:*

16.1.1 Check correct operation of the instrument with the test probe.

16.1.2 Connect the instrument to the probe and follow the manufacturer's instructions. Some instruments have manual zero adjustments, application, and reading of polarization current. Other instruments make these readings automatically. Some instruments use probes with electrodes whose area is adjusted for the assumed equivalent weight of the alloy (see 4.2.2) to give a direct readout of corrosion rate. Other instruments use probes with electrodes always of the same area. These latter instruments are normally calibrated for carbon steel. Other alloys are determined from a theoretical or empirical multiplier applied to the instrument reading. In general, these instruments display a corrosion rate assuming a B value (see 4.2.2) that is generally typical for cooling water environments.

16.1.3 Manual or automatic instruments all require a minute to several minutes to obtain a reading. During the measurement sufficient time must be allowed for the double layer capacitance at the electrodes (see Fig. 1) to become charged before readings are determined.

16.1.4 Since the polarization resistance technique records only the corrosion rate at the time of the reading, measurements should be taken frequently and recorded or plotted on a graph against time. For effective coverage, continuous monitoring is advisable.

16.1.5 To check for variations in the corrosion rate of the process, and for instrument repeatability, it is advisable to take two or three readings for each measurement required, if possible reversing the polarity of the applied potential on each measurement.

#### 16.2 *Automatic Continuous Monitoring Instruments:*

16.2.1 These instruments are available in various single or multi-channel configurations that may be stand-alone systems or interfaced with process computers, or both. These units provide continuous information on instantaneous corrosion rates.

16.2.2 These systems should be installed and tested according to the manufacturer's instructions. Test probes are normally provided to assist the set-up of all channels of the system.

16.2.3 Connect the operational probes onto the system.

16.2.4 Instrument outputs are in the form of various standard process signals, meter or digital indication, or recorder traces of the measured corrosion rate, or all of the above. Generally the most useful form of data is the graph of corrosion rate versus time for each monitored point.

## 17. Interpretation of Results

17.1 Based on theoretical considerations of various corrosion mechanisms of metals, it can be shown that the value of B can vary by a factor of 8 (2). In the broad range of practical applications, the variation is generally limited to factors of 2 or 3. If representative Tafel slopes are determined or a multiplier based on mass loss of electrodes is used, the factor is generally reduced to around 1.25. Variation in the B value and the limitations of assumptions in 12.1.1 makes the technique less

suitable for determination of absolute corrosion rate, but useful in determining the relative change in corrosion rates.

17.2 For manual instruments, corrosion rates are calculated based on the relationships in 4.2.2. Most instruments have a nominal B value for carbon steel built into the instrument for ease of use. Other alloys are accommodated by different electrode sizes or by an alloy multiplier.

17.3 For automatic instruments, the output will usually be directly in corrosion rate unit of mils per year (mil = 0.001 in.) or mm per year based on a nominal B value. Some instruments have provision for modifying the nominal B value.

17.4 Careful interpretation is necessary in correlating these corrosion test results with actual metal corrosion in the plant. Comparison with metal coupon results (See Guide G4), mass loss on the probe electrode, or actual metal exposed in the plant is suggested to establish reliability as to estimation of service life. For comparative inhibitor tests or process upset detection the absolute value of the corrosion rate is often less critical than the relative magnitude of the change.

## 18. Keywords

18.1 corrosion monitoring in plant equipment; electrical resistance method of corrosion measurement; online corrosion monitoring; polarization resistance method of corrosion measurement

## APPENDIX

### (Nonmandatory Information)

#### X1. DERIVATIONS AND EXAMPLES OF OPERATING LIMITS GIVEN ON Fig. 2

##### X1.1 Corrosion Rate and Solution Resistance Calculation

X1.1.1 From Eq 2 and Eq 4:

$$\text{corrosion rate} = \frac{k_1 \times B \times E.W.}{\rho \times R_p} \quad (\text{X1.1})$$

X1.1.2 Assuming density of carbon steel at 7.86 g/cm<sup>3</sup>, a B value of 27.5 mV, and an equivalent weight of 27.92:

$$\begin{aligned} \text{corrosion rate} &= \frac{0.1288 \times 10^6 \times 0.0275 \times 27.92}{7.86 \times R_p} \quad (\text{X1.2}) \\ &= \frac{12.58 \times 10^3}{R_p} \text{ mpy} \end{aligned}$$

X1.1.3 From Note 4 and Note 5 on Fig. 2:

$$\text{solution resistance} = R_s = \frac{0.55 \times 10.6}{\text{conductivity } (\mu\text{mhos/cm})} \quad (\text{X1.3})$$

##### X1.2 Derivation of Curve 3 on Fig. 2 (see 12.5.1.1)

X1.2.1

$$\text{Measured polarization resistance} = R_{pm} = R_p + \frac{R_s}{2}. \quad (\text{X1.4})$$

X1.2.2 When  $\frac{\text{measured corrosion rate}}{\text{actual corrosion rate}} = 0.8$ ; that is, 20 % error as Note 2 on Fig. 2:

$$\frac{R_p}{R_{pm}} = \frac{2R_p}{2R_p + R_s} = 0.8 R_p = 2R_s \quad (\text{X1.5})$$

X1.2.3 By substitution of Eq X1.2 and Eq X1.3 in X1.1, Curve 3 in Fig. 2 is generated. Conductivity ( $\mu\text{mhos/cm}$ ) = 87.44  $\times$  corrosion rate (mpy).

##### X1.3 Derivation of Curve 2 on Fig. 2 (see 12.5.1.2)

X1.3.1 Based on X1.2.3 of Fig. 2:

$$\text{measured } R_p = R_p + \frac{R_s}{20} \quad (\text{X1.6})$$

X1.3.2 When  $\frac{\text{measured corrosion rate}}{\text{actual corrosion rate}} = 0.8$ ; that is, 20 % error as Note 2 on Fig. 2.

$$\frac{R_p}{R_{pm}} = \frac{20R_p}{20R_p + R_s} = 0.8 R_p = 0.2R_s \quad (\text{X1.7})$$

X1.3.3 By substitution of Eq X1.2 and Eq X1.3 in X1.1, Curve 2 in Fig. 2 is generated. Conductivity ( $\mu\text{mhos/cm}$ ) = 8.744  $\times$  corrosion rate (mpy).



**TABLE X1.1 Examples of Errors in Polarization Resistance Techniques, (Reference Fig. 2)**

Probe Configuration	Text Section	Location on Fig. 2	Conductivity (μmhos/cm)	Measured Rp ohms-cm <sup>2</sup>	True Value Rp ohms-cm <sup>2</sup>	Error in <sup>A</sup> Corrosion Rate, %
2 electrode	11.5.1.1	A	2000	1395.5	1258	- 9.9
3 electrode (triangular configuration)	11.5.1.1	A	2000	1395.5	1258	- 9.9
2 electrode	11.5.1.1	B	500	1808	1258	- 30.4
3 electrode (triangular configuration)	11.5.1.1	B	500	1808	1258	- 30.4
3 electrode close-space reference	11.5.1.2	C	100	1533	1258	- 17.9
2 electrode	11.5.1.3	C	100	1156.6	1258	+ 8.77
+ high frequency compensation				1359.3		-7.46
2 electrode + high frequency compensation	11.5.1.3	D	20	826.6	1258	+ 52.2
				1689.4		- 25.5

$$^A \text{ Error in corrosion rate} = \frac{C.R_m - C.R}{C.R} = \frac{1/R_{pm} - 1/R_p}{1/R_p} = \frac{R_p - R_{pm}/R_p R_{pm}}{1/R_p} = \frac{R_p - R_{pm}}{R_{pm}} = \frac{R_p}{R_{pm}} - \frac{R_{pm}}{R_{pm}} = \frac{R_p}{R_{pm}} - 1.$$

**X1.4 Derivation of Curve 1 on Fig. 2 (see 12.5.1.3)**

X1.4.1 From Fig. 1 the electrochemical impedance between the two electrodes, namely the test and auxiliary electrode is as follows:

$$Z = R_s + \frac{2R_p}{1 + \omega^2 R_p^2 C_{dl}^2} - j \frac{2\omega R_p^2 C_{dl}}{1 + \omega^2 R_p^2 C_{dl}^2} \quad (X1.8)$$

where:

$\omega$  = frequency of applied signal.

X1.4.2 When a high frequency measurement is made between the two electrodes to provide correction for solution resistance to the initial normal polarization resistance measurement, the first measurement from normal polarization resistance is as follows:

$$R_1 = R_p + \frac{R_s}{2} \quad (X1.9)$$

X1.4.3 The second measurement at high frequency is as follows:

$$R_2 = \sqrt{\left(\frac{R_s}{2} + \frac{R_p}{1 + \omega^2 R_p^2 C_{dl}^2}\right)^2 + \left(\frac{\omega R_p^2 C_{dl}}{1 + \omega^2 R_p^2 C_{dl}^2}\right)^2} \quad (X1.10)$$

X1.4.4 By algebraic subtraction of the two measurements to give the measured polarization resistance:

$$R_p \text{ measured} = R_1 - R_2 \quad (X1.11)$$

X1.4.5 When  $\frac{\text{measured corrosion rate}}{\text{actual corrosion rate}} = 0.8$ ; for example, 20 % error as in Note 2 on Fig. 2:

$$\frac{R_p}{R_{pm}} = \frac{R_p}{R_1 - R_2} = 0.8 \quad (X1.12)$$

By reiterative substitution of values based on X1.3 of Fig. 2, Curve 1 in Fig. 2 is generated.<sup>5</sup>

**X1.4.6 Calculation Example:**

Conductivity μmhos/cm	100	100
Corrosion rate mpy	24	23
Actual polarization resistance $R_p$ (ohm-cm <sup>2</sup> )	524.17	546.96
Polarization resistance measurement ( $R_1$ )	3274.17	3296.96
with + 1.5 % error ( $R_3$ )	3323.28	3346.40
with - 1.5 % error ( $R_4$ )	3225.06	3247.50
High frequency measurement ( $R_2$ )	2750.05	2750.05
with + 1.5 % error ( $R_5$ )	2791.30	2791.30
with - 1.5 % error ( $R_6$ )	2708.80	2708.80
Measured polarization resistance range		
( $R_3 - R_6$ )	614.49	637.62
( $R_4 - R_5$ )	433.76	456.21
Error range in corrosion rate measurement <sup>5</sup>	+ 20.8 %	+ 19.9 %
	-14.7 %	- 14.2 %

$$^5 \text{ Error in corrosion rate} = \frac{C.R_m - C.R}{C.R} = \frac{1/R_{pm} - 1/R_p}{1/R_p} = \frac{R_p - R_{pm}/R_p R_{pm}}{1/R_p} = \frac{R_p - R_{pm}}{R_{pm}} = \frac{R_p}{R_{pm}} - \frac{R_{pm}}{R_{pm}} = \frac{R_p}{R_{pm}} - 1.$$

**REFERENCES**

- (1) Freedman, A. J. and Canapary, R. C., "Corrosion Monitoring by the Electrical Resistance Method," *Oil in Canada*, August 24, 1959.
- (2) NACE Publication 3D170, "Electrical and Electrochemical Methods for Determining Corrosion Rates," (1984 revision).
- (3) Dean, S. W., "Overview of Corrosion Monitoring in Modern Industrial Plants," *ASTM STP 908*, ASTM International, pp. 197–218.
- (4) Cooper, G., "Sensing Probes and Instruments for Electrochemical and Electrical Resistance Corrosion Monitoring," *ASTM STP 908*, ASTM International, pp. 237–250.
- (5) Cameron, G. R. and Coker, L. G., "Oil Production Corrosion Inhibitor Optimization by Laboratory and Field Application of Electrochemical Techniques," *ASTM STP 908*, ASTM International, pp. 251–265.
- (6) Crowe, D. C., and Yeske, R. D., "Corrosion Rate Monitoring in Kraft Pulping Process Liquids," Paper No. 272, *Corrosion/86*, March 1986.
- (7) Stern, M., "A Method for Determining Corrosion Rates from Linear Polarization Data," *Corrosion*, Vol 14, 1958, p. 440t.
- (8) Simmons, E. J., "Use of the Pearson Bridge in Corrosion Inhibitor Evaluation," *Corrosion*, Vol II, 1955, p. 255t.
- (9) Skold, R. V., and Larson, T. E., "Measurement of Instantaneous Corrosion Rates by Means of Polarization Data," *Corrosion*, Vol 13, 1957, p. 139t.
- (10) March, G. A., and Schaschl, E., "Instantaneous Corrosion-Rate Measurements and Their Use in the Study of Corrosion Inhibitors," *API Division of Refining*, Vol 44, III, 1964, pp. 166–171.
- (11) March, G. A., "The Measurement of Instantaneous Corrosion Rates," Second International Congress of the Metallic Corrosion, New York City, March 10, 1963.
- (12) Annand, R. R., "An Investigation of the Utility of Instantaneous Corrosion Rate Measurement for Inhibitor Studies," *Corrosion*, Vol 22, 1966, p. 215.
- (13) Feitler, H., "Instantaneous Corrosion Measurement," *Materials Protection and Performance*, Vol 9, October 1970, p. 37.
- (14) Townsend, C. R., "Comparison of Two and Three Electrode Polarization Resistance Methods of Corrosion Measurements," Paper No. 64, *Corrosion/74*, March 1974.
- (15) Callow, L. M., Richardson, J. A., and Dawson, J. L., "Corrosion Monitoring Using Polarization Resistance Measurements, II. Sources of Error," *British Corrosion Journal*, Vol 11, No. 3, March 1976, p. 132.
- (16) Heitz, E., and Schwenk, W., "Theoretical Basis for the Determination of Corrosion Rates for Polarization Resistance," *British Corrosion Journal*, Vol 11, No. 2, February 1976, p. 74.
- (17) Mansfeld, F., *Corrosion*, Vol 13, 1975, p. 416 (discussion of paper by Barnart, *Corrosion*, Vol 31, p. 164).
- (18) Mansfeld, F., *Corrosion*, Vol 32, 1976, p. 143.
- (19) Mansfeld, F., "The Polarization Resistance Technique for Measuring Corrosion Currents," *Advances in Corrosion Science and Technology*, Vol 6, 1976, pp. 163–262.
- (20) Haruyama, S., and Tsuru, T., "A Corrosion Monitor Based on Impedance Method," *ASTM STP 727*, ASTM International, pp. 167–186.
- (21) Mansfeld, F., "Evaluation of Electrochemical Techniques for Monitoring of Atmospheric Corrosion Phenomena," *ASTM STP 727*, ASTM International, pp. 215–237.
- (22) Kucera, V., and Gullman, J., "Practical Experience with an Electrochemical Technique for Atmospheric Corrosion Monitoring," *ASTM STP 727*, ASTM International, pp. 238–255.
- (23) Liening, E. L., "Trouble-Shooting Industrial Corrosion Problems with Electrochemical Testing Techniques," *ASTM STP 908*, ASTM International, pp. 289–304.
- (24) Labine, P., Norman, W., Kind, D., and Minalga, J., "Techniques for the Evaluation of Cooling Water Corrosion and Scale Inhibitors in the Laboratory and at the Industrial Plant Site," *ASTM STP 908*, ASTM International, pp. 307–313.
- (25) Rizzi, R., and Ronchetti, C., "On-Line Monitoring of the True Corrosion Rate in Problems Related to Power Plants," *ASTM STP 908*, ASTM International, pp. 314–338.

*ASTM International takes no position respecting the validity of any patent rights asserted in connection with any item mentioned in this standard. Users of this standard are expressly advised that determination of the validity of any such patent rights, and the risk of infringement of such rights, are entirely their own responsibility.*

*This standard is subject to revision at any time by the responsible technical committee and must be reviewed every five years and if not revised, either reapproved or withdrawn. Your comments are invited either for revision of this standard or for additional standards and should be addressed to ASTM International Headquarters. Your comments will receive careful consideration at a meeting of the responsible technical committee, which you may attend. If you feel that your comments have not received a fair hearing you should make your views known to the ASTM Committee on Standards, at the address shown below.*

*This standard is copyrighted by ASTM International, 100 Barr Harbor Drive, PO Box C700, West Conshohocken, PA 19428-2959, United States. Individual reprints (single or multiple copies) of this standard may be obtained by contacting ASTM at the above address or at 610-832-9585 (phone), 610-832-9555 (fax), or service@astm.org (e-mail); or through the ASTM website (www.astm.org). Permission rights to photocopy the standard may also be secured from the Copyright Clearance Center, 222 Rosewood Drive, Danvers, MA 01923, Tel: (978) 646-2600; http://www.copyright.com/*