



# Standard Test Method for Measuring Rolling Friction Characteristics of a Spherical Shape on a Flat Horizontal Plane<sup>1</sup>

This standard is issued under the fixed designation G194; the number immediately following the designation indicates the year of original adoption or, in the case of revision, the year of last revision. A number in parentheses indicates the year of last reapproval. A superscript epsilon ( $\epsilon$ ) indicates an editorial change since the last revision or reapproval.

## 1. Scope

1.1 This test method covers the use of an angled launch ramp to initiate rolling of a sphere or nearly spherical shape on a flat horizontal surface to determine the rolling friction characteristics of a given spherical shape on a given surface.

1.1.1 Steel balls on a surface plate were used in interlaboratory tests (see [Appendix X1](#)). Golf balls on a green, soccer and lacrosse balls on playing surfaces, bowling balls on an lane, basketballs on hardwood, and marbles on composite surface were tested in the development of this test method, but the test applies to any sphere rolling on any flat horizontal surface.

1.1.2 The rolling friction of spheres on horizontal surfaces is affected by the spherical shape's stiffness, radius of curvature, surface texture, films on the surface, the nature of the counterface surface; there are many factors to consider. This test method takes all of these factors into consideration. The spherical shape of interest is rolled on the surface of interest using a standard ramp to initiate rolling and standard techniques to measure and treat the rolled distance after leaving the ramp.

1.1.3 This test method produces a rolling resistance number on a specific spherical shape on a specific surface. It is intended for comparing similar tribosystems. For example, the rolling resistances of marbles on a particular surface are not to be compared with the rolling resistance of soccer balls on grass, because their masses and diameters are very different as are the counterface surfaces on which they roll.

1.1.4 Different launch ramps for are appropriate for different types of spherical shapes. If a sphere of interest cannot be accommodated with using one of the launch ramps discussed in [Appendix X1](#) and [Appendix X2](#), a different launch ramp can be developed and added with future revisions to this test method.

1.2 The values stated in SI units are to be regarded as standard. No other units of measurement are included in this standard.

1.3 *This standard does not purport to address all of the safety concerns, if any, associated with its use. It is the responsibility of the user of this standard to establish appropriate safety and health practices and determine the applicability of regulatory limitations prior to use.*

## 2. Referenced Documents

2.1 *ASTM Standards:*<sup>2</sup>

[G40 Terminology Relating to Wear and Erosion](#)

[G115 Guide for Measuring and Reporting Friction Coefficients](#)

[G143 Test Method for Measurement of Web/Roller Friction Characteristics](#)

## 3. Terminology

3.1 *Definitions:*

3.1.1 *rolling friction force,  $n$* —in tribology, a force, opposite to the direction of rolling, resisting rolling of a spherical shape, ball, roller, wheel, etc. forced against and rolling in a direction on another surface. **G40**

3.2 *Definitions of Terms Specific to This Standard:*

3.2.1 *coefficient of rolling resistance (CORR)*—dimensionless measure of rolling retardation experienced by a spherical shape (sphere and the like) on a flat horizontal plane of interest; it is the ratio of the vertical distance between the sphere's point of contact with the launch ramp and the horizontal plane divided by the distance rolled on the horizontal plane after leaving the launch ramp.

3.2.2 *rolling resistance number (RR)*,  $n$ —dimensionless measure of the retardation produced on a spherical shape rolling on a flat horizontal surface: the higher the number, the higher the retardation. This number is obtained by multiplying the CORR by 100.

## 4. Summary of Test Method

4.1 A vee-shaped launch ramp with known height, length and vee angle is placed on a flat and level (most flat and level

<sup>1</sup> This test method is under the jurisdiction of ASTM Committee G02 on Wear and Erosion and is the direct responsibility of Subcommittee G02.50 on Friction.

Current edition approved Nov. 15, 2013. Published November 2013. Originally approved in 2008. Last previous edition approved in 2008 as G194 – 08. DOI: 10.1520/G0194-13.

<sup>2</sup> For referenced ASTM standards, visit the ASTM website, [www.astm.org](http://www.astm.org), or contact ASTM Customer Service at [service@astm.org](mailto:service@astm.org). For *Annual Book of ASTM Standards* volume information, refer to the standard's Document Summary page on the ASTM website.

portion) of a surface of interest and a sphere (ball bearing, orange, golf ball, etc.) is rolled down the ramp onto the test surface. The distance traveled after exiting the ramp is measured. The ratio of the height of the spherical shape's outside diameter above the test surface (plane) to the distance rolled after leaving the ramp is the coefficient of rolling resistance. The test concept is that the potential energy of the sphere raised to a height (mass  $\times$  height) is equated to the rolling energy of the released sphere (mass  $\times$  distance rolled). The energy is manifested in distance traveled after leaving the launch ramp. The distance traveled is the test metric, and this distance is affected by the nature of the spherical shape and rolling surface. The test method can be used to compare the rolling characteristics of different spherical shapes/surface textures on a constant rolling surface or a constant spherical shape on different rolling surfaces to compare ease of rolling. Different shaped ramps and angles are have been used for different spherical objects (**Appendix X2**). Data developed with one procedure cannot be readily compared with data developed using one of the other procedures since the spherical shapes, launch ramps, and rolling surfaces are different.

## 5. Significance and Use

5.1 Rolling friction like sliding friction depends upon many factors. It is a system effect that involves the nature of the rolling surface and the counterface. The sliding friction force ( $F$ ) is usually considered to be the sum of forces arising from deformations of surface features ( $F_s$ ), from attractive forces (atomic, molecular, etc.) at contact points ( $F_a$ ) and force from interaction of films and particulates on the rubbing surfaces ( $F_f$ ):

$$F = F_a + F_s + F_f \quad (1)$$

The rolling friction force includes these force contributions plus effects from the relative stiffness of the contacting surfaces, the diameter (curvature) of the spherical shape (ball, orange, etc.) and other factors. Because there are so many factors involved in a rolling tribosystem, rolling resistance can best be quantified by an actual test of the sphere of interest on the intended counterface, as in this test method.

5.2 There are countless applications where it is important to quantify the rolling characteristics of a particular spherical shape on a particular surface. The interlaboratory tests conducted for this test method were performed on hardened steel balls like those used in ball bearings. This test method could be used to assess the effect of different counterface surfaces on the rolling characteristics of balls for ball bearings. Conversely, it could be used as a quality control test on balls. Surface imperfections/defects/films, etc. on the balls can affect how they roll: the distance traveled on a common counterface.

5.3 Industrial applications of this test method can include assessing conveying surfaces for spherical or nearly special parts: check valve balls, cabinet knobs, Christmas ornaments, toilet floats, etc. Many medical devices use special shapes where rolling characteristics are a consideration. Similarly, many pharmaceutical products (pills) are spherical or nearly spherical in shape, and this test method can be used to assess rolling characteristics for conveying or other reasons such as size (mass) check.

5.4 Rolling friction of spherical shapes can be a consideration in countless sports (soccer, golf, lacrosse, etc.) and game applications (billiards, bocce, toys, etc.). This test method can be used to rank the rolling resistance of different ball compositions, masses, shapes, surface textures, design, stiffness, etc. Similarly, the test method can be used to assess the ease of rolling of balls on different playing or game surfaces.

5.5 This test method is very applicable to spherical or mostly spherical food products. For example, it is common to use rolling distance of apples, citrus, nuts, etc. to classify them by size for marketing. They are rolled down an angled surface and the rolling distance becomes a function of size (mass/diameter). This test method can be used to assess the suitability of various rolling surfaces (carpet, metal, wood, etc.) for suitability in classification equipment. It could also be used for food conveyance on spherical-shaped processed foods (gumballs, hard candy, meatballs, etc.)

5.6 Finally, this test method can be a valuable teaching tool for physics and tribology students. The equipment is simple, low cost and student proof. It can be used to demonstrate the concept of rolling friction and the factors that affect it.

## 6. Apparatus

6.1 A typical launch ramp for small-diameter balls is shown in **Fig. X2.1**. The ramp can be made from any metal with a cold-finished surface roughness in the range of 0.1 and 0.3- $\mu\text{m}$  roughness average. Corrosion-resistant materials (aluminum, stainless steel) are preferred as the material of construction of the launch ramp since the rolling surface can be subject to corrosion from rain, dew, handling, etc.

6.2 **Fig. 1** shows a launch ramp schematic that includes the necessary design elements of a suitable launch ramp. The distance rolled after the spherical shape leaves the ramp ( $d$ ) is the test metric. These design elements are:

- (1) A vee shape to cradle the sphere.
- (2) A reference surface that locates the sphere at the top of the ramp.
- (3) A ramp height ( $h$ ), length ( $l$ ), and angles (vee and ramp) ( $^\circ$ ) suitable for the size and mass of the sphere (**Appendix X2.1**).
- (4) The delivery end of the ramp must be tapered to minimize "drop-off" as the sphere exits the ramp.

## 7. Procedure

### 7.1 Test Procedure:

7.1.1 Place the launch ramp on the flat, horizontal surface of interest.

7.1.2 Remove all obvious films and debris from handling on the ramp, sphere, and counterface.

7.1.3 Place the sphere at the top of the launch ramp touching the reference surface.

7.1.4 Release the sphere without added sideward, forward, or backward forces. Small balls can be held in two fingers and released; large balls can be held with both hands or a device can be used to hold the ball until release.

7.1.5 Measure the distance traveled from the launch ramp end with a meter stick, tape measure, etc. If the rolling

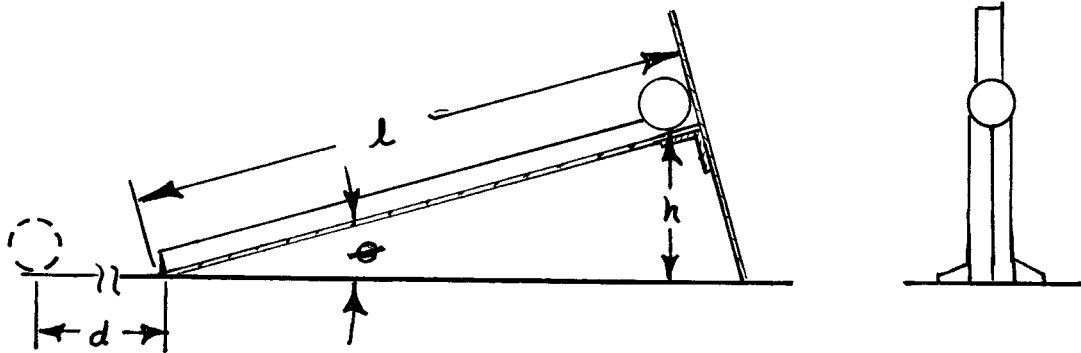

NOTE 1—The launch ramp dimensions used in Option B tests were:

- l = 40 cm,
- h = 13 cm,
- Vee = 110°, θ = 20°,
- Material = cold rolled 6061T6 aluminum.

FIG. 1 Schematic of a Typical Launch Ramp

distances are less than 500 cm, round the result to one decimal place (for example, 31.3 cm).

7.1.6 Calculate the coefficient of rolling resistance (CORR) for the tribosystem using the following equation:

$$CORR = h/d \quad (2)$$

where:

- CORR** = may be converted to RR by multiplying by 100. This term may be preferred for some applications since it usually results in a whole number (after rounding) that increases with rolling resistance or rolling friction
- h** = the vertical distance between the sphere's point of contact with the launch ramp and the horizontal rolling plane.
- d** = the distance that the sphere rolled (to a stop) after exiting the inclined plane

7.2 Ten replicates are recommended. It is not necessary to use a new travel path for each test if the rolling surface is robust and not irreversibly deformed during testing.

NOTE 1—The length of the ramp is neglected in the CORR calculation. Its length is neglected because this length just becomes a constant added to the (d) measurements made in the test. It does play a role in retarding the rolling of the sphere and it must be kept clean and debris free. Data obtained with one ramp should not be compared with data obtained with a launch ramp with a different height and length.

## 8. Report

8.1 It is important to describe fully the rolling member and the rolling counterface. For example, the newness, condition and cleanliness of a sphere should be stated along with pertinent counterface conditions such as method of manufacture, surface texture, etc. Helpful documents for recording data are Guide G115 and Test Method G143. A typical test report is shown in Fig. 2.

## 9. Precision and Bias

9.1 There is no standard rolling surface that can be evaluated with this test method, therefore, no bias can be defined.

Date:	_____
Time:	_____
<b>Material Couple:</b>	_____
Rolling element	_____
Rolling surface	_____
<b>Test Conditions:</b>	_____
Temperature	_____
Relative humidity	_____
Ramp height	_____
Ramp length	_____
Other	_____
<b>Results:</b>	_____
Rolling distances	_____
Average	_____
Std. deviation	_____
Coefficient of rolling resistance (CORR)	_____
Rolling resistance (RR)	_____

FIG. 2 Rolling Friction Test Report

9.1.1 Appendix X1 shows results of interlaboratory tests conducted with two different diameter hardened (60 HRC) 52100 steel balls rolling on precision surface plates. The test balls came from the same lot. The surface plates were of different materials, but all were level and flat within 50 μm in 30 cm. The coefficient of variation ranged from 0.02 to 0.108.

9.1.2 Appendix X2.1 contains nonmandatory information on ramps used in the development of this test method. Coefficient of variation in these tests ranged from 0.04 to 0.12.

9.2 Sources of Variability—Nicks and other discontinuities and films on the test ramp or rolling surface can affect test results.

## 10. Keywords

10.1 balls; coefficient of rolling friction; plane; rolling friction; spheres

**APPENDIXES**

**(Nonmandatory Information)**

**X1. INTERLABORATORY TEST RESULTS**

**X1.1 Tests**

X1.1.1 Tests were conducted using 6.3-mm and 9.5-mm diameter 52100 hardened steel (60 HRC) balls on precision surfaces (surface plates, optical bench).

Launch ramp height: 0.5/0.55 cm,

Length: 13.4/14.5 cm,

Vee angle: 110/120°,

Material: 6061T6 aluminum, cold finished.

**X1.2 Analysis**

X1.2.1 The coefficient of variation ranged from 0.02 to 0.108. The absolute distance values are different for each rolling surface because the rolling surfaces were different in material, surface texture, cleanliness, etc. Thus, these data show within-lab test variability, not between lab variability. See [Table X1.1](#).

**TABLE X1.1 Distance Rolled after Leaving the Launch Ramp**

	Test	6.3-mm ball	9.5-mm ball
Lab 1 (BLS) Stainless steel optical bench	1	20	26
	2	21	28
	3	20	27
	4	20	30
	5	22	33
	6	22	31
	7	21.5	29
	8	20	32
	9	22	29
	10	19	27
		$x = 20.75$	$x = 29.2$
		$s = 1.08$	$s = 2.3$
		$COV = 0.05$	$COV = 0.08$
Lab 2 (IT) Granite surface plate	1	37.5	57
	2	36.2	58.4
	3	39.7	59.3
	4	40	58.7
	5	36.2	58.7
	6	37.1	57.5
	7	37.6	59.8
	8	36.5	59
	9	37.1	57
	10	40.3	60
		$x = 37.8$	$x = 58.8$
		$s = 1.6$	$s = 1.1$
		$COV = 0.04$	$COV = 0.02$
Lab 3 (BLN) Cast iron surface plate	1	16	27
	2	16	32
	3	16	33
	4	17	32
	5	16	31
	6	21	36
	7	18.5	29
	8	16	32
	9	16.5	34
	10	17	30
		$x = 17$	$x = 31.6$
		$s = 1.6$	$s = 2.5$
		$COV = 0.09$	$COV = 0.08$
Lab 4 (CMM) Granite surface plate	1	110	>152 (fell off table)
	2	108	144
	3	122	135
	4	114	>152
	5	102	>152
	6	105	>152
	7	135	>152
	8	124	>152
	9	103	>152
	10	124	>152
		$x = 114.7$	
		$s = 11$	
		$COV = 0.09$	
EDM Granite surface plate	1	163	207
	2	140	223
	3	159	210
	4	171	220
	5	140	>229 (fell off table)
	6	(not applicable)	202
	7	145	178
	8	124	217
	9	142	203
	10	128	199
		$x = 145.7$	$x = 206.5$
		$s = 15.7$	$s = 13.5$
		$COV = 0.108$	$COV = 0.065$

**X2. LAUNCH RAMPS USED FOR VARIOUS SPHERICAL SHAPES DURING TEST DEVELOPMENT**

X2.1 For details and results, see **Tables X2.1-X2.6** and **Figs. X2.1-X2.4**.

**TABLE X2.1 Ramp Details**

Spherical Shape/Procedure		Nominal <sup>A</sup> Height (h), cm	Length, cm	Vee Angle, degrees	Material	Surface
Steel balls (interlaboratory tests)	Option A— <b>Fig. X2.1</b>	0.5/0.55	13.5/14.5	110/120	Aluminum	Cold finished
Golf and lacrosse balls	Option B— <b>Fig. X2.2</b>	13/14	39/41	100/110	Aluminum	Cold finished
Large balls (soccer, volleyball, etc.)	Option C— <b>Fig. X2.3</b>	39/41	103/105	120/160	Oak	Sanded and varnished
Bowling ball	Option D— <b>Fig. X2.4</b>	2.5 ± 1 mm	103/105	140/150	Oak	Sanded and varnished

<sup>A</sup> Test height may be different depending on the test surface (grass, carpet, etc.)

**TABLE X2.2 COV for Different Ramp Options**

Application	Ramp	COV
Lacrosse ball versus short (5 cm) grass	Ramp B	0.09
Lacrosse ball versus high (10 cm) grass	Ramp B	0.07
12.7-mm diameter steel ball versus cast iron	Ramp A	0.035
12.7-mm diameter zirconia ball versus cast iron	Ramp A	0.124
Bowling ball versus clean parquet flooring	Ramp D	0.047
Bowling ball versus parquet flooring plus sawdust	Ramp D	0.054
Basketball versus hardwood flooring	Ramp C	0.044

**TABLE X2.3 Repeatability for a Golf Ball on a Green Using Option B**

Distance Same Balls Traveled, cm		
Green 1 Golfer 1	Green 2 Golfer 2	Green 3 Golfer 3
71	62	150
80	69	152
82	69	144
76	69	152
80	72	160
80	72	161
80	75	152
77	74	152
81	75	150
80	64	159
$\bar{X} = 78.7$	$\bar{X} = 70.1$	$\bar{X} = 153.2$
$s = 3.2$	$s = 4.43$	$s = 5.2$
COV = 4.1%	COV = 6.3%	COV = 3.4%

**TABLE X2.4 Rolling Differences between Golf Balls from Various Manufacturers on the Same Rolling Surface**

NOTE 1—Low pile carpet and Option B ramp.

Ball	Weight, g	Average Travel Distance	Std. Deviation
S	45.4312	154.170	1.8
W	45.8891	161.8	1.8
R	45.2181	154.18	2.2
P	45.4172	154.7	1.5
Y	45.9450	154.7	1.5
D	46.2124	145.8	2.5

**TABLE X2.5 Rolling Resistance Number of Various Golf Ball-Rolling Counterfaces**

NOTE 1—Same ball rolling on different surfaces. Ten replicates using Option B ramp.

Surface	CORR	Rolling Resistance Number
2-in. high rough	0.6	60
Wet level green	0.2	20
Same green dry	0.109	10
Smooth concrete	0.025	3
Hardwood flooring	0.019	2
Low-pile carpet	0.1	10
Stone (pea) walkway	0.25	25
Macadam walkway	0.083	8

**TABLE X2.6 Billiard Ball on Low-Pile Cloth Surface Using Launch Ramp B**

Average Distance Traveled	COV	CORR	Rolling Resistance Number
178 in.	0.04	0.0937	9.4

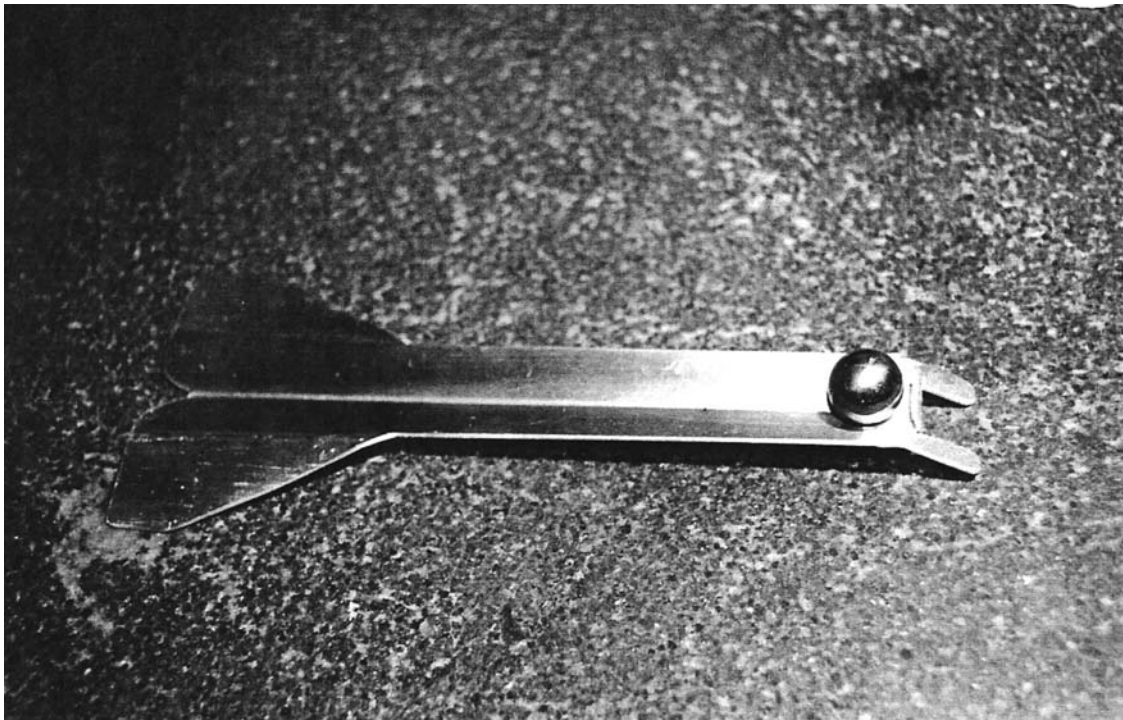

**FIG. X2.1 Launch Ramp for Small Diameter (< 25 mm) Balls (Option A)**

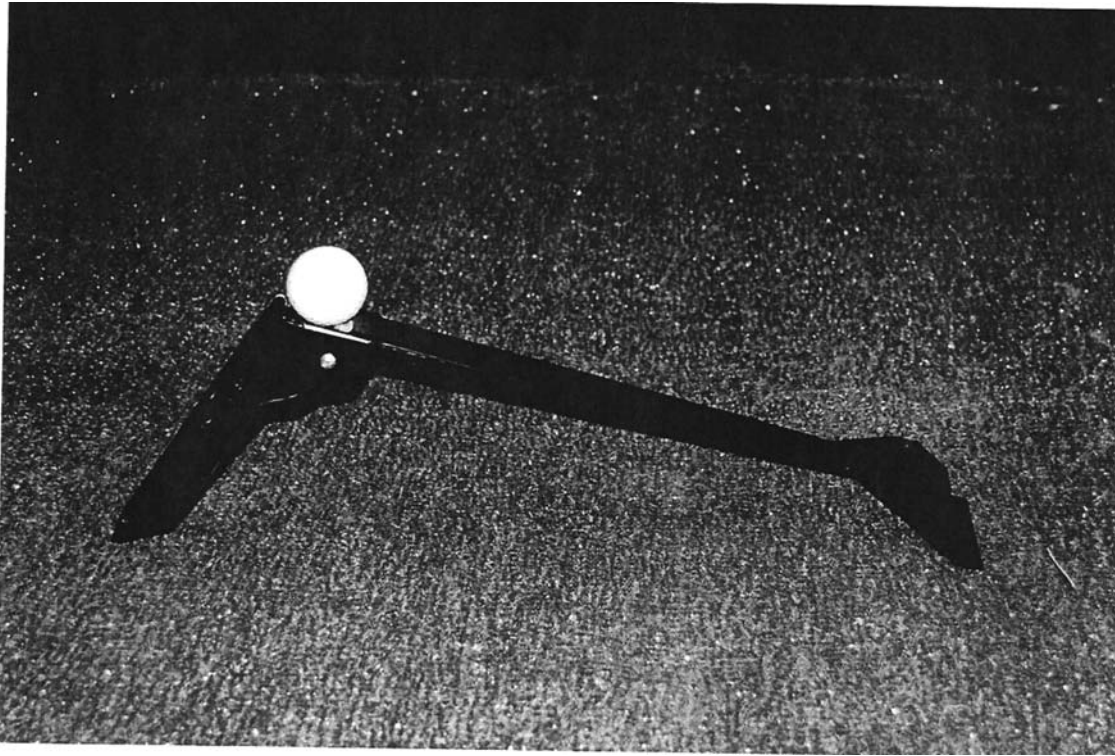

FIG. X2.2 Launch Ramp for Golf Balls on a Golf Green (Option B)

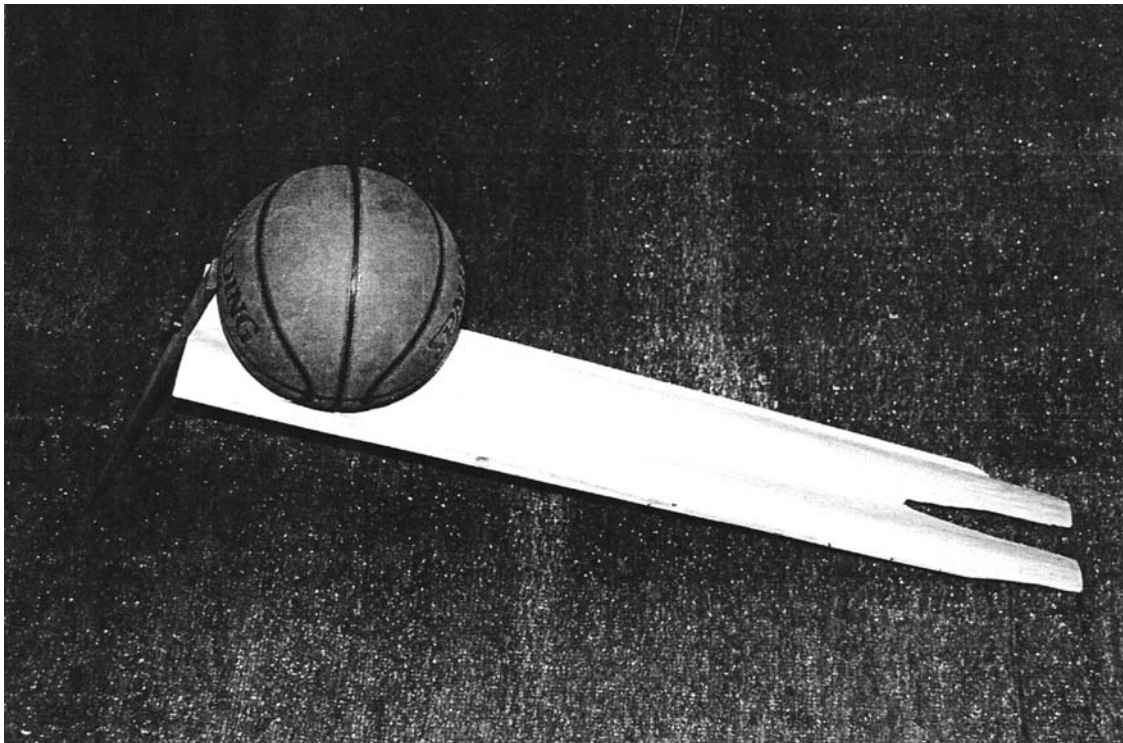
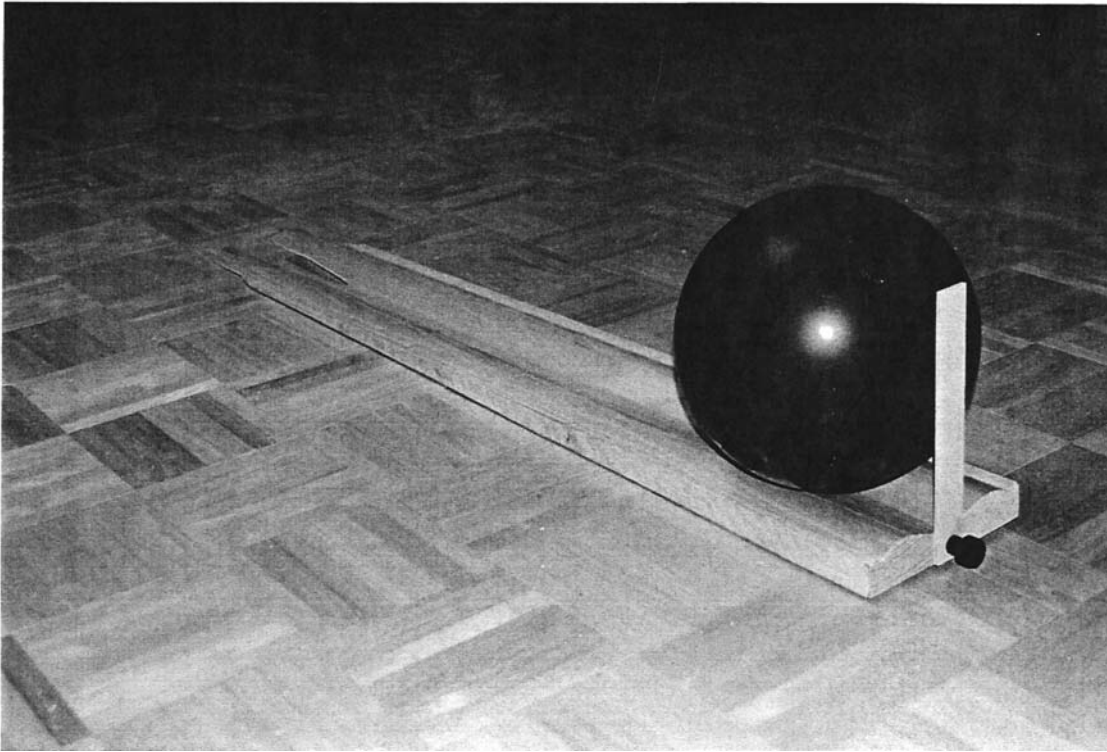

FIG. X2.3 Launch Ramp Used for Soccer and Other Large Balls (Option C)





**FIG. X2.4 Launch Ramp for Bowling Balls (Option D)**

*ASTM International takes no position respecting the validity of any patent rights asserted in connection with any item mentioned in this standard. Users of this standard are expressly advised that determination of the validity of any such patent rights, and the risk of infringement of such rights, are entirely their own responsibility.*

*This standard is subject to revision at any time by the responsible technical committee and must be reviewed every five years and if not revised, either reapproved or withdrawn. Your comments are invited either for revision of this standard or for additional standards and should be addressed to ASTM International Headquarters. Your comments will receive careful consideration at a meeting of the responsible technical committee, which you may attend. If you feel that your comments have not received a fair hearing you should make your views known to the ASTM Committee on Standards, at the address shown below.*

*This standard is copyrighted by ASTM International, 100 Barr Harbor Drive, PO Box C700, West Conshohocken, PA 19428-2959, United States. Individual reprints (single or multiple copies) of this standard may be obtained by contacting ASTM at the above address or at 610-832-9585 (phone), 610-832-9555 (fax), or service@astm.org (e-mail); or through the ASTM website (www.astm.org). Permission rights to photocopy the standard may also be secured from the Copyright Clearance Center, 222 Rosewood Drive, Danvers, MA 01923, Tel: (978) 646-2600; <http://www.copyright.com/>*