



Standard Test Method for Measurement of Soil Resistivity Using the Two-Electrode Soil Box Method¹

This standard is issued under the fixed designation G187; the number immediately following the designation indicates the year of original adoption or, in the case of revision, the year of last revision. A number in parentheses indicates the year of last reapproval. A superscript epsilon (ϵ) indicates an editorial change since the last revision or reapproval.

1. Scope

1.1 This test method covers the equipment and procedures for the measurement of soil resistivity, for samples removed from the ground, for use in the assessment and control of corrosion of buried structures.

1.2 Procedures allow for this test method to be used in the field or in the laboratory.

1.3 The test method procedures are for the resistivity measurement of soil samples in the saturated condition and in the as-received condition.

1.4 The values stated in SI units are to be regarded as the standard. The values given in parentheses are for information only. Soil resistivity values are reported in ohm-centimeter.

1.5 *This standard does not purport to address all of the safety concerns, if any, associated with its use. It is the responsibility of the user of this standard to establish appropriate safety and health practices and to determine the applicability of regulatory limitations prior to use.*

2. Referenced Documents

2.1 *ASTM Standards:*²

D1193 Specification for Reagent Water

E691 Practice for Conducting an Interlaboratory Study to Determine the Precision of a Test Method

G57 Test Method for Field Measurement of Soil Resistivity Using the Wenner Four-Electrode Method

G193 Terminology and Acronyms Relating to Corrosion

2.2 *UNS Standards:*³

UNS Designation S30400 & S30403

UNS Designation S31600 & S31603

¹ This test method is under the jurisdiction of ASTM Committee G01 on Corrosion of Metals and is the direct responsibility of Subcommittee G01.10 on Corrosion in Soils.

Current edition approved Nov. 1, 2012. Published March 2013. Originally approved in 2005. Last previous edition approved in 2012 as G187-12. DOI: 10.1520/G0187-12A.

² For referenced ASTM standards, visit the ASTM website, www.astm.org, or contact ASTM Customer Service at service@astm.org. For *Annual Book of ASTM Standards* volume information, refer to the standard's Document Summary page on the ASTM website.

³ UNS (Unified Numbering System) was developed jointly by ASTM International and SAE International.

3. Terminology

3.1 *Definitions:*

3.1.1 *Ohm's law, n*—The relationship between the electromotive force, the current, and the resistance. Mathematically: current = electromotive force/resistance or $I = E/R$; where "I" is measured in amperes, "E" in volts, and "R" in ohms.

3.1.2 *resistivity (soil), n*—The electrical resistance between opposite faces of a unit cube of material; the reciprocal of conductivity.

3.1.3 *saturated soil, n*—soil whose entire soil porosity is filled with water.

3.1.4 *soil box factor, n*—A factor which is determined by a two-electrode soil box's internal dimensions (cross sectional area/distance between electrode plates). The soil box factor is multiplied by the measured resistance of a substance in the soil box to obtain that substance's resistivity.

3.1.5 *soil resistance meter, n*—An instrument capable of measuring soil resistance.

3.1.6 *two-electrode soil box, n*—A non-conductive container of known internal dimensions with two end plate electrodes for measuring a substance's resistivity.

3.2 The terminology used herein, if not specifically defined otherwise, shall be in accordance with Terminology G193. Definitions provided herein and not given in Terminology G193 are limited only to this standard.

4. Summary of Test Method

4.1 The two-electrode soil box method is predicated on measuring the resistance between two opposite faces of a box containing a substance or solution. That resistance measurement through the substance being tested is then converted to resistivity based on the conversion formula of Eq 1.

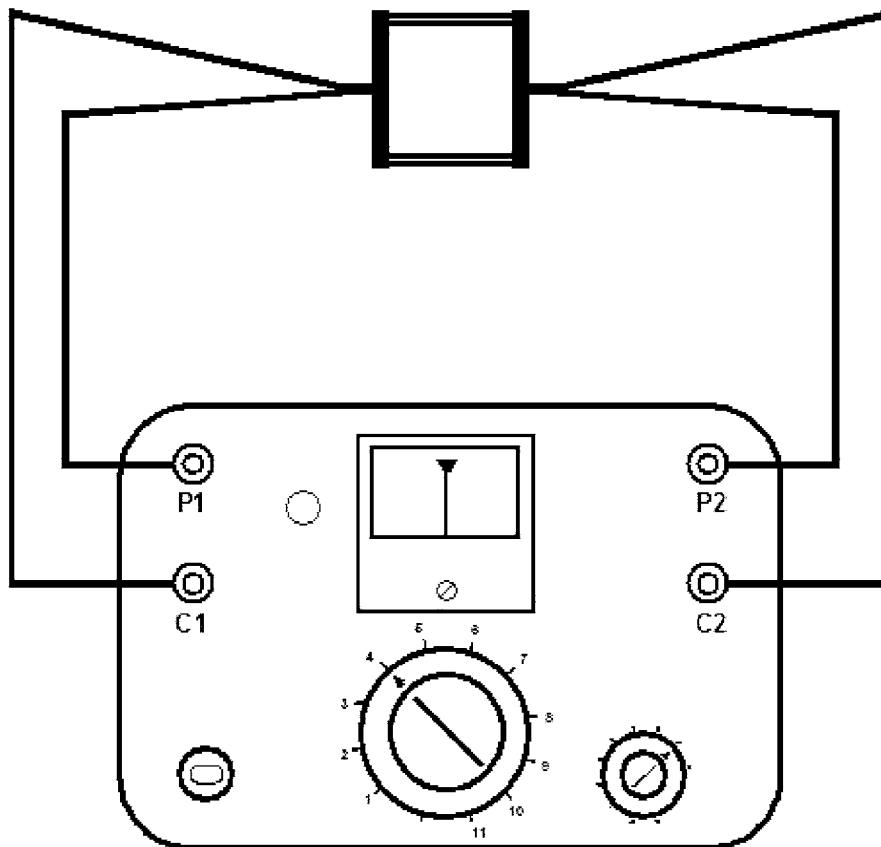

FIG. 1 Typical Connections for Use of Soil Box with Soil Resistance Meter

4.2 A voltage is applied to the opposing electrodes and the resulting current is measured. Ohm’s law reveals the resistance. The resistivity, ρ , is then:

$$\rho \text{ (ohm - cm)} = AR/d \quad (1)$$

where:

A = exposed area of one electrode face, cm^2 ,

R = resistance, ohms, and

d = distance between electrodes, cm.

5. Significance and Use⁴

5.1 The resistivity of the surrounding soil environment is a factor in the corrosion of underground structures. High resistivity soils are generally not as corrosive as low resistivity soils. The resistivity of the soil is one of many factors that influence the service life of a buried structure. Soil resistivity may affect the material selection and the location of a structure.⁵

⁴ Method of Test for the Resistivity of Soils Material, Texas State Department of Highways and Public Transportation – Materials and Tests Division, Test Method Tex-129-E, November 1986.

⁵ Method for Estimating the Service Life of Steel Culverts, California State Department of Transportation – Engineering Service Center, California Test 643, November 1999.

5.2 Soil resistivity is of particular importance and interest in the corrosion process because it is basic in the analysis of corrosion problems and the design of corrective measures.

5.3 The test method is focused to provide an accurate, expeditious measurement of soil resistivity to assist in the determination of a soil’s corrosive nature. Test Method **G57** emphasizes an *in situ* measurement commonly utilized in the design of a buried structures’ corrosion control (cathodic protection systems’ ground bed design, and so forth). The two-electrode soil box method often compliments the four-pin, *in situ* soil resistivity method.

5.4 The saturated soil resistivity determined by this test method does not necessarily indicate the minimum soil resistivity.

6. Apparatus

6.1 The equipment required for the measurement of the resistivity of soil samples, either in the field or in the laboratory, consists of a two-electrode soil box, a soil resistance meter, wiring to make the necessary connections and a soil extraction tool with straightedge. A two-electrode soil box, soil resistance meter and its electrical connections are shown in **Fig. 1**.

304L or 316L Electrodes

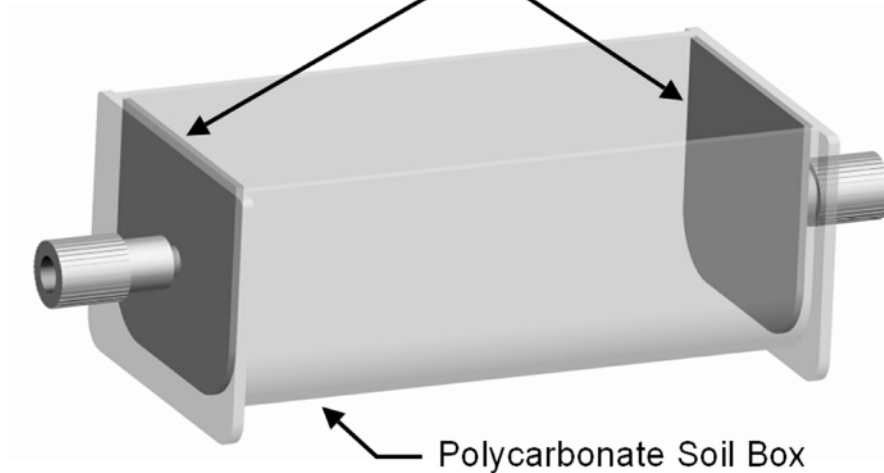

Compacted Soil Sample

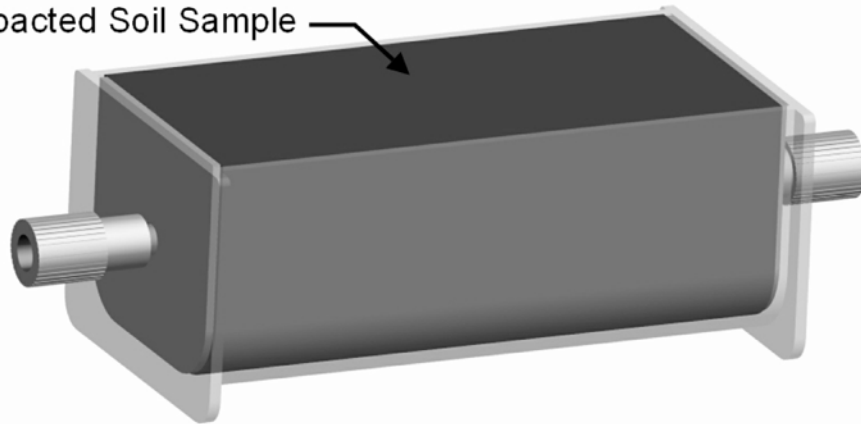

FIG. 2 Typical Two-Electrode Soil Box (Empty and Full)

6.2 *Two-Electrode Soil Box*—Two-electrode soil boxes can be constructed in various sizes provided the inside dimensions are known. Design and construction shall incorporate materials that are durable and machinable. The two end plate electrodes shall be constructed of a clean, polished corrosion-resistant metal or alloy (that is, UNS Designation type S30400/S30403 or UNS S31600/S31603 stainless steel) that will not form a heavy oxide film or otherwise add significant resistance. The body of the box shall be constructed of a material that is non-conductive and able to maintain its desired dimensions (polycarbonate plastics). The box shall be readily cleanable to avoid contamination by previous samples. See Fig. 2.

6.3 *Soil Resistance Meter*—Commercially available soil resistance meters are commonly used for measuring soil resistivity. They offer convenience, ease of use, and repeatability. Soil resistance meters yield direct readings in ohms, which are multiplied by the appropriate factor for the specific two-electrode soil box. The meter utilized may limit the upper range of resistivity, which can be measured. In such cases, the resistivity should be reported as greater than the meter’s upper limit.

6.4 *Wiring*—18 to 22 AWG insulated stranded copper wire.

NOTE 1—It is important to make reliable, low-impedance electrical connections. Ensure that all terminals are clean, and all wiring connections are made securely.

7. Reagents and Materials

7.1 Distilled or deionized water (Type IV grade as referenced in Specification D1193) to saturate samples.

8. Sampling Test Specimens, and Test Units

8.1 Collected soil samples that are to be tested in the laboratory shall be placed in an appropriate sealable container or polyethylene type bag to prevent contamination. Each sample shall be clearly marked with the location, depth, collection date, and sample temperature at the time of collection.

NOTE 2—The resistivity of a soil sample does not typically change over time. However, it is advisable to conduct your tests typically within a few weeks after sample collection to avoid any unforeseen changes. It is also advisable to avoid prolonged exposure of samples to extreme heat or direct sunlight.

8.2 Soil samples shall be representative of the area of interest. Where the stratum of interest contains a variety of soil types, it is desirable to sample each type separately.

8.3 The collected soil sample size is dependent on the volume of the soil box used. Be sure to collect enough soil to allow for compaction during the test. It is also advisable to collect extra soil in case repeated testing becomes necessary.

8.4 Soil resistivity measurements shall not be conducted on frozen or partially frozen soil samples. Soil samples to be tested in the laboratory shall be allowed to reach room temperature (approximately 20°C (68°F)) prior to the resistivity measurement. Field measurements shall reflect the soils temperature during testing. Soil temperatures that are above freezing can be corrected for a uniform temperature of 15.5°C (60°F) by use of the following equation:⁶

$$R_{15.5} = R_t (24.5 + t)/40 \quad (2)$$

where $R_{15.5}$ is the resistance at 15.5°C (60°F) and R_t is the observed resistance at temperature t °C.

9. Calibration and Standardization

9.1 The accuracy of the soil resistance meter shall be periodically checked with a commercial resistance decade box or several appropriate known value resistors. Meter error shall not exceed 5 % over the range of the instrument. If error exceeds this limit, the meter should be recalibrated as soon as possible. Until such time, a calibration curve can be established and used to correct all measurements.

9.2 The two-electrode soil box can be calibrated using solutions of known resistivity. Commercially available solutions (VWR Conductivity Calibration Standards⁷) in the range of 1000, 5000, and 10,000 ohm-cm are recommended for this purpose. Calibration checks are generally performed biannually.

10. Procedure

10.1 Procure enough soil sample for testing to accommodate the soil box.

10.2 Examine the sample for the presence of foreign material such as gravel, small stones, roots, twigs, and so forth, which shall be removed from the sample.

10.3 Fill the soil box by adding increments of soil. Mix distilled or deionized water into each soil increment to saturate and help the ionic components of the soil go into solution. Do not oversaturate the soil. Compact each wetted soil increment as densely as possible by hand. Make certain that voids are eliminated. Continue this filling procedure until soil box is slightly over full. Using the straightedge portion of the soil extraction tool, level off the excess hand compacted soil so the soil conforms to the total volume of the soil box. Add a slight

amount more of distilled or deionized water to ensure the hand compacted sample is saturated but not oversaturated (the presence of a moisture sheen on top of the sample is desirable). This procedure will allow for a resistivity measurement of the soil in a saturated condition.

NOTE 3—Other soil box resistivity measurement techniques and equipment are available. More detailed procedures related to the addition of water and compaction of the soil may be employed in controlled laboratory investigations, which should be defined in reporting the results. Where resistivity information is included in published information, the measurement techniques used should be defined.

10.4 Connect the soil resistance meter to the soil box as shown in Fig. 1 and record the resistance measurement. Multiply the resistance measurement value by the appropriate soil box factor to obtain the soil resistivity.

10.5 When requested to supply as-received sample results, perform the same procedures of steps 10.1-10.4, but eliminate the addition of water.

10.6 The soil resistance measurement using the two-electrode soil box will include the soil resistance between the two electrodes and the interface resistance between the soil sample and the electrode. Tests and experience has shown that this interface resistance is negligible.

11. Calculation or Interpretation of Results

11.1 Each individual soil box will have a unique factor dependent upon the internal dimensions of the box. Example: A soil box with inside dimensions of 4 cm × 4 cm × 4 cm will have a soil box factor of 4:

$$\rho = AR/d \quad (3)$$

$$\rho = 4 \text{ cm} \cdot 4 \text{ cm} \cdot R/4 \text{ cm}$$

$$\rho = 4 \cdot R \text{ (ohm-cm)}$$

where:

A = cross sectional area, cm²,

R = resistance, ohm, and

d = distance between electrode plates, cm.

12. Report

12.1 Report the following information at a minimum:

12.1.1 Technician performing the test.

12.1.2 Model of soil resistivity meter being used.

12.1.3 Soil box factor.

12.1.4 Measured resistance in ohms for each sample (this may be helpful later if the calculated value below becomes suspect.)

12.1.5 Calculated resistivity value for the sample in ohm-cm.

12.1.6 Temperature of the sample at time of collection.

12.1.7 Temperature of the sample during measurement.

12.1.8 Date when the sample was collected.

12.1.9 Date when the sample was tested.

12.1.10 Depth of the sample.

12.1.11 Location of the sample.

12.1.12 Any other information that may facilitate the subsequent interpretation.

12.1.13 Any deviation from this test method.

⁶ Davis, R.O.E., "The use of the electrolytic bridge for determining soluble salts," U. S. Dept. Agriculture, Circular 423, 1927.

⁷ The sole source of supply of the apparatus known to the committee at this time is VWR International, 1310 Goshen Parkway, West Chester, PA 19380, USA. If you are aware of alternative suppliers, please provide this information to ASTM International Headquarters. Your comments will receive careful consideration at a meeting of the responsible technical committee,¹ which you may attend.

TABLE 1 ILS in Tampa, Florida on November 18, 2003

NOTE 1—Tropical soil resistivity measurements by seven participants.

	Soil #1	Soil #2	Soil #3
Average resistivity, ohm-cm	2297	450	19580
Repeatability standard deviation, s_r , ohm-cm	106	41	1190
Repeatability coefficient of variation, CV, %	4.6	9.1	6.1
Reproducibility standard deviation, s_R , ohm-cm	318	41	1720
Reproducibility coefficient of variation, CV, %	13.9	9.1	8.8

12.2 For a sample test report, see [Fig. X1.1](#).

13. Precision and Bias

13.1 *Precision*—The precision of this test method was determined by a statistical evaluation of an interlaboratory study per Practice [E691](#). The data from this evaluation are available from ASTM in a research report.⁸ A summary of these data is given in [Table 1](#).

13.1.1 *Repeatability*—Repeatability refers to the variation in results obtained by the same operator with the same equipment and the same operating conditions in successive

⁸ Supporting data have been filed at ASTM International Headquarters and may be obtained by requesting Research Report RR:G01-1022.

tests. In the case of soil resistivity measurements, the repeatability may be characterized by a coefficient of variation, $CV\%_r$, representing the repeatability standard deviation divided by the average result and expressed in percent. The ILS results indicate a repeatability coefficient of variation of 6.6 %. The 95 % confidence interval is $2.8(CV\%_r)$ or 18.5 %.

13.1.2 *Reproducibility*—Reproducibility refers to the variation in results that occurs when different operators measure the same soil. In the case of soil resistivity measurements reproducibility may be characterized by a coefficient of variation, $CV\%_R$, representing the reproducibility standard deviation divided by the average result and expressed in percent. The ILS results indicate a reproducibility coefficient of variation of 10.6 %. The 95 % confidence interval is $2.8(CV\%_R)$ or 29.7 %.

13.2 *Bias*—The procedure in this test method for the measurement of soil resistivity using the two-electrode soil box has no bias because the value of the two-electrode soil box soil resistivity is defined only in terms of this test method.

14. Keywords

14.1 soil box; soil box factor; soil resistivity; two-electrode soil box

APPENDIX

(Nonmandatory Information)

X1. SAMPLE DATA FORM

X1.1 A sample data form is provided in [Fig. X1.1](#).

Soil Resistivity Test using the Two-Electrode Soil Box Method

Company / Laboratory: _____	Technician: _____
Test Date: _____	Tests Performed: On-Site <input type="checkbox"/> In Lab <input type="checkbox"/>
Meter Used: _____	Soil Box Factor: _____

Equipment and supplies

- | | |
|---|--|
| <input type="checkbox"/> Soil resistivity meter
<input type="checkbox"/> Wiring or test leads per section 6.4
<input type="checkbox"/> Two-electrode soil box (or four-electrode soil box configured for two-electrode operation)
<input type="checkbox"/> Hand tools for digging samples
<input type="checkbox"/> Sealable containers or baggies | <input type="checkbox"/> Pen or marker
<input type="checkbox"/> Thermometer or temperature probe
<input type="checkbox"/> Tape measure
<input type="checkbox"/> Water to saturate samples (see section 7.1 for specifications)
<input type="checkbox"/> Soil extraction tool with straightedge (for compacting and leveling soil sample in soil box, and for cleaning soil box after test) |
|---|--|

Sample#	Sample Location	Sample Depth	Collection Date	Sample Temperature At Time Of Test	Measured Resistance (Ω)	Calculated Resistivity* (Ω-cm)	Comments

*Calculated as shown in section 4.2.

FIG. X1.1 Example of a Soil Resistivity Test Form

ASTM International takes no position respecting the validity of any patent rights asserted in connection with any item mentioned in this standard. Users of this standard are expressly advised that determination of the validity of any such patent rights, and the risk of infringement of such rights, are entirely their own responsibility.

This standard is subject to revision at any time by the responsible technical committee and must be reviewed every five years and if not revised, either reapproved or withdrawn. Your comments are invited either for revision of this standard or for additional standards and should be addressed to ASTM International Headquarters. Your comments will receive careful consideration at a meeting of the responsible technical committee, which you may attend. If you feel that your comments have not received a fair hearing you should make your views known to the ASTM Committee on Standards, at the address shown below.

This standard is copyrighted by ASTM International, 100 Barr Harbor Drive, PO Box C700, West Conshohocken, PA 19428-2959, United States. Individual reprints (single or multiple copies) of this standard may be obtained by contacting ASTM at the above address or at 610-832-9585 (phone), 610-832-9555 (fax), or service@astm.org (e-mail); or through the ASTM website (www.astm.org). Permission rights to photocopy the standard may also be secured from the ASTM website (www.astm.org/COPYRIGHT).