



Standard Test Method for Joints, Fittings, and Patches in Coated Pipelines¹

This standard is issued under the fixed designation G18; the number immediately following the designation indicates the year of original adoption or, in the case of revision, the year of last revision. A number in parentheses indicates the year of last reapproval. A superscript epsilon (ϵ) indicates an editorial change since the last revision or reapproval.

1. Scope

1.1 This test method describes determination of the comparative corrosion preventative characteristics of materials used for applications to joints, couplings, irregular fittings, and patched areas in coated pipelines. The test method is applicable to materials whose principal function is to act as barriers between the pipe surface and surrounding soil environment.

1.2 The test method described employs measurements of leakage current, capacitance, and dissipation factor to indicate changes in the insulating effectiveness of joint and patching materials.

1.3 The values stated in SI units are to be regarded as the standard. The values given in parentheses are for information only.

1.4 *This standard does not purport to address all of the safety concerns, if any, associated with its use. It is the responsibility of the user of this standard to establish appropriate safety and health practices and determine the applicability of regulatory limitations prior to use.*

1.5 The values stated in SI units to three significant decimals are to be regarded as the standard. The values given in parentheses are for information only.

2. Referenced Documents

2.1 *ASTM Standards*:²

G12 Test Method for Nondestructive Measurement of Film Thickness of Pipeline Coatings on Steel (Withdrawn 2013)³

3. Summary of Test Method

3.1 The test method consists of an immersion test where coated pipe specimens, each containing a simulated joint, tee,

¹ This test method is under the jurisdiction of ASTM Committee D01 on Paint and Related Coatings, Materials, and Applications and is the direct responsibility of Subcommittee D01.48 on Durability of Pipeline Coating and Linings.

Current edition approved June 1, 2013. Published June 2013. Originally approved in 1971. Last previous edition approved in 2007 as G18–07. DOI: 10.1520/G0018-07R13.

² For referenced ASTM standards, visit the ASTM website, www.astm.org, or contact ASTM Customer Service at service@astm.org. For *Annual Book of ASTM Standards* volume information, refer to the standard's Document Summary page on the ASTM website.

³ The last approved version of this historical standard is referenced on www.astm.org.

or patched area, are suspended in an electrolyte and placed under cathodic protection by connecting the specimens to the negative (–) terminal of a 6-V d-c power supply (see Fig. 1). An anode, also immersed in the electrolyte and connected to the positive (+) terminal of the power supply, completes the test circuit. Joint or patch performance is followed through periodic determinations of leakage current measured as voltage drops across a calibrated resistor in the anode-to-cathode circuit.

3.2 Capacitance and dissipation factor measurements are used to supplement the periodic leakage current determinations.

4. Significance and Use

4.1 The exposed metal surfaces at joints, fittings, and damaged areas in an otherwise coated pipeline will be subjected to corrosion if allowed to come in contact with the soil environment. The performance of joint and patching materials designed to function as protective coverings will depend upon such factors as the ability of the material to bond to both the pipe coating and exposed metal surfaces, the integrity of the moisture seal at lapped joints, and the water absorption characteristics of the joint material.

4.2 The existence of substantial leakage current through the coating joint, patch, or fitting is reliable evidence that the material has suffered a significant decrease in its performance as a protective barrier. In a similar manner, measured changes in joint capacitance and dissipation factor are useful because they are related to the water absorption rate of the joint material. Water permeating an insulating barrier increases its capacitance and its progress can be measured through the use of a suitable impedance bridge.

5. Apparatus

5.1 *Test Vessel*, nonconducting, shall be used to contain the test specimens. Dimensions of the vessel shall permit the following requirements:

5.1.1 The test vessel shall be large enough to allow for suspension of the specimens in a vertical position and equidistant from a centrally located anode. The specimens shall not touch either each other, the walls, or bottom of the test vessel.

5.1.2 The test vessel shall be deep enough to allow for immersion of the specimens in the electrolyte to the lower edge

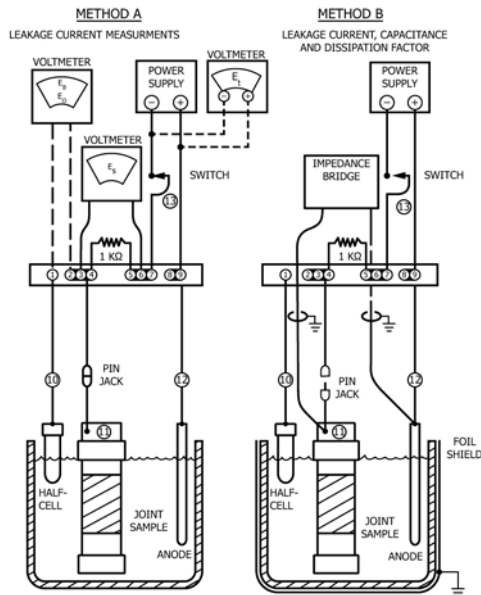
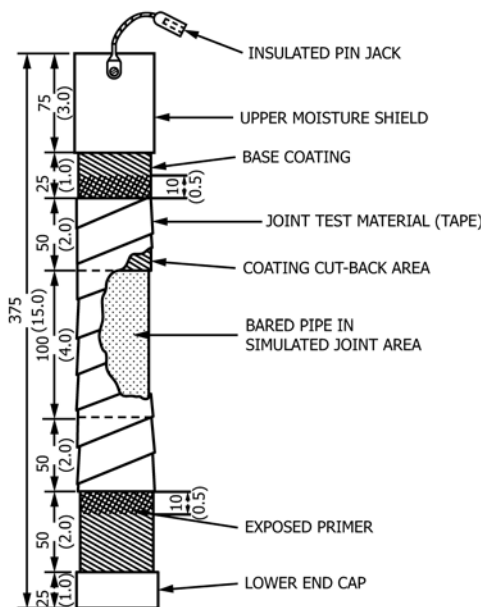

FIG. 1 Test Circuits

of the upper moisture shield (see Fig. 2).



NOTE 1—All dimensions are in millimetres with inches in parentheses.

FIG. 2 Joint Test Specimen

NOTE 1—A commercially available, 42 L (11-gal) waste container of high-density polyethylene can be conveniently used as a test vessel and will accommodate up to six test specimens of a size indicated in 7.2.

5.2 *Support Plate*, fabricated from a nonconductive material, to suspend the specimens in the test vessel. The support plate shall contain an access hole for the reference electrode. A typical test cell is illustrated in Fig. 3.

5.3 *Anode*, fabricated from 9.525 mm (0.375-in.) diameter 300 series stainless steel rod, 609.6 mm (24.00 in.) long. Other inert anodes such as carbon or platinum may be used.

5.4 *D-C Voltmeter*, to serve the dual purpose of (1) measuring leakage current as a potential drop across a 1,000-Ω shunt in the measuring circuit and (2) measuring the potential of the test specimen with reference to a Cu-CuSO₄ half cell. The instrument characteristics for these functions shall be:

5.4.1 *Voltage Range*—50 μV full scale to 10 V full scale in overlapping 1× and 3× ranges.

5.4.2 *Accuracy*—±3 percent of full scale on all ranges.

5.4.3 *Input Resistance*—Greater than 10 MΩ on all ranges.

5.5 *Thickness Gage*—Measurements of coating thickness will be required for this test. Any instrument suitable for use with Test Method G12 can be used. However, the choice of measuring gage shall be compatible with the joint coating thickness that will be encountered in the test.

5.6 *Ohmmeter*—Measurements for end-cap integrity shall be made with a suitable ohmmeter capable of reading resistance to an upper limit of 1000 MΩ ± 5 %.

5.7 *Reference Electrode*—A Cu-CuSO₄ half cell of conventional glass or plastic tube with porous plug construction, but preferably not over 19.05 mm (¾ in.) in diameter, having a potential of -0.316 V with respect to the standard hydrogen electrode.

NOTE 2—A saturated calomel half cell may be used, but measurements made with it shall be converted to the Cu-CuSO₄ reference for reporting

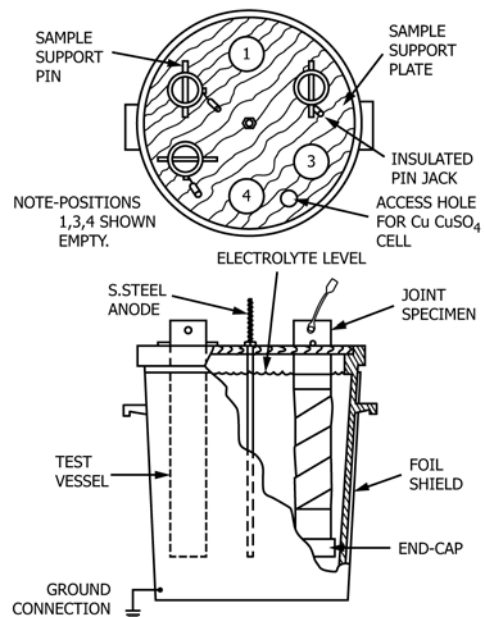

FIG. 3 Joint Test Cell

by adding -0.072 V to the observed reading.

5.8 Voltage Source—A battery or rectifier-type power supply shall be used to maintain a potential difference of 6.0 ± 0.1 V dc between each of the test specimens and the Cu-CuSO₄ half cell. Where multiple specimens are tested, a suitable voltage-dividing circuit will be required for individual control of the voltage applied to each specimen.

5.9 Circuit Wiring from the anode to specimen shall be of No. 18 Awg insulated copper. A switch for disconnecting each specimen from its voltage source shall be included in the circuit. A1000 $\Omega \pm 1$ percent, 1-W (minimum) precision resistor shall be placed in the anode-to-cathode circuit as a shunt for current. A diagram illustrating the test cell wiring appears as **Fig. 1**.

5.10 Capacitance Bridge—Measurements of specimen capacitance and dissipation factor shall be made with a low-voltage a-c, resistive ratio arm-type bridge having the following characteristics:

5.10.1 Oscillator Frequency, 1 kHz ± 2 % tolerance.

5.10.2 Series Capacitance Range, 100 pF to 1100 pF accuracy ± 1 % ± 1 pF, whichever is larger.

5.10.3 Dissipation Factor Range, 0.002 to 1.0 at 1 kHz accuracy ± 5 % or ± 0.001 dissipation, whichever is larger.

5.11 Connectors—Miniature, pin-type, insulated jacks shall be used at the point of connection to each test specimen. The jacks serve two important functions: (1) they permit the disconnection of the specimen from the voltage source when the impedance bridge is in use, and (2) disconnection of the specimen from the test circuit also removes the effect of stray capacitance due to excessive lead length that may introduce error into impedance bridge measurements.

5.12 Foil Shield—As an additional safeguard against stray capacitance effects, wrap the entire test vessel in heavy-gage aluminum foil as shown in **Fig. 3** and ground the shield.

6. Materials

6.1 Electrolyte—The electrolyte shall consist of potable tap water with the addition of 3 weight percent of technical-grade sodium chloride.

6.2 Materials for sealing the ends of the specimens may consist of waxes, epoxies, or other suitable materials. However, they should have a dielectric constant in the range from 2 to 6, and exhibit a low water-absorption rate. It is also important that the end-cap material maintains good adhesion to any coated pipe surfaces throughout the test period.

7. Test Specimen

7.1 The joint specimen shall be prepared from a representative piece of 60.325 mm (2.375 in.) outside diameter, Schedule 40, production-coated pipe.

7.2 Each piece of coated pipe shall be 381 mm (15.0 in.) long and serve as a carrier for the particular joint material to be tested.

7.3 The simulated coating joint shall be made by cleaning away a 101.6 mm (4.0-in.) band of pipe coating starting from a point 203.2 mm (8.0 in.) below the upper end of the pipe. The

coating may be removed by power brushing or any other suitable device that will remove all of the coating in the area indicated and leave a clean metal surface behind.

7.4 The lower end of the test specimen shall be plugged flush with a stopper and sealed or capped with a material meeting the requirements of **6.2**.

7.5 When used, the primer shall be applied to the test specimen in sufficient quantity to coat the test specimen from a point 88.9 mm (3.50 in.) below its upper end and ending at a point 317.5 mm (12.5 in.) from the upper end. This will allow for a 12.7-mm (0.5-in.) band of excess primer beyond each tape margin.

7.6 The joint material to be tested shall be applied to the prepared pipe specimen (using a spiral wrap for tapes) and starting from a point 101.6 mm (4.0 in.) below the upper end of the pipe section and ending at a point 304.8 mm (12.0 in.) from the upper end. The 203.2 mm (8.0 in.) of joint material thus applied should overlap the bared section of pipe by 50.8 mm (2.0 in.) at each end. This distance represents the typical cut-back distance encountered in the field joining, through welding, of coated pipe in 60.325 mm (2.375 in.) outside diameter size. A diagram of the joint specimen appears as **Fig. 2**.

7.7 The manner of applying the joint material shall be done in accordance with the manufacturer's specifications. The supplier of the joint material should specify the desired time interval between the application of the material and the start of the test.

NOTE 3—Materials that are intended for use as a field-applied patch over damaged areas on coated pipelines can be tested using the same procedures, with the patching compound applied, instead, to the bared area of the simulated joint.

7.8 The upper 76.2 mm (3.0 in.) of the completed joint test specimen shall be coated with the material used for the lower end cap. This moisture shield can be conveniently made, in the case of some waxes and epoxies, with several successive brush or dip-applied applications. The thickness of the moisture shield should be approximately 3.175 mm (0.125 in.).

8. Testing Temperature

8.1 Perform all tests at a room temperature of 21 to 25°C (70 to 77°F).

9. Preliminary Test Measurements

9.1 Coating and Joint Thickness—Measure and record the thickness of the base coating which lies exposed at each end of the test joint. Measurements shall be made in accordance with Test Method **G12**. In a like manner, measure and record the average thickness of the joint covering.

10. Procedure for Leakage Current Measurements

10.1 Suspend the joint test specimens in the test vessel, observing the clearances specified in **5.1.1** and **5.1.2**. Fill the vessel with electrolyte, bringing the fluid level up to a point midway between the end cap and the lower edge of the joint material.

10.2 Connect one terminal of the ohmmeter to the test specimen and the other terminal to the central anode. The anode should be in contact with the electrolyte. Measure the apparent sample-to-anode resistance in ohms. The reading shall remain above 1000 MΩ for 15 min. Readings below this value probably indicates a faulty end-cap seal which should be repaired before the joint specimen is totally immersed.

10.3 Totally immerse the joint test specimens up to the lower edge of the moisture shield. This level shall be maintained throughout the test period by regular additions of tap water. The test shall be performed at room temperature.

10.4 Connect each joint test specimen in series with a 1000-Ω ± 1 % (1-W) resistor, a suitable switch, and the negative (–) terminal of the voltage source.

10.5 Connect the central stainless steel anode to the positive (+) terminal of the voltage source.

10.6 Energize the voltage source. Adjust the voltage to each specimen by connecting a voltmeter between each sample and the Cu-CuSO₄ half cell and varying the voltage output until 6.0 V are measured between sample and half cell (see Fig. 1).

10.7 As soon as the circuit is energized and voltage adjusted to each joint test specimen, measure and record the voltage across each 1000-Ω shunt resistor.

10.8 Measure and record the closed circuit potential, E_B , and open circuit potential, E_o , of each joint specimen with reference to the saturated Cu-CuSO₄ half cell.

NOTE 4—Any drop in closed circuit potential (E_B) of a joint specimen greater than 20 % of the terminal voltage (E_V) probably indicates a developing current leak in the joint area. In a like manner, any open circuit potential (E_o) greater than 0.05 V may indicate the presence of a developing conductive path across the test joint. (Both voltages are referenced to the Cu-CuSO₄ half cell.)

10.9 Using the d-c voltmeter in 5.4 measure and record the voltage appearing across the terminals of the voltage supply.

10.10 Continue, on a periodic basis, the measurements specified in 10.7 through 10.9. Calculate the apparent joint resistance by the method described in 12.1.

10.11 Prior to removal, reexamine a suspected joint failure to confirm that any observed drop in joint resistance is not due to a faulty end-cap seal. This can best be accomplished by removing the specimen from the test cell and allowing it to dry. When dry, reimmerse it to just above the level of the lower end cap and check the integrity of the cap by the method outlined in Section 8.

11. Procedure for Measurement of Capacitance and Dissipation Factor

11.1 The series capacitance and dissipation factor between each joint sample and the central stainless-steel anode shall also be measured. These measurements shall be made at the time of initial immersion and continued on an identical schedule with the voltage readings. They shall be made in the following manner:

11.2 Temporarily disconnect the test specimen from the voltage source. Connect the impedance bridge between the test specimen and stainless-steel anode. Energize the bridge and

measure the equivalent series capacitance, C , and dissipation factor, DF , or the test specimen using a “null” technique to balance the measuring bridge.

11.3 A continued rise in joint capacitance and dissipation factor from the values recorded at the time of initial immersion, will indicate progressive absorption of water by the joint material.

11.4 The joint test shall continue for 180 days or until the joint resistance falls to a value of 4600 Ω for 1 m² (50 000Ω for 1 ft²) of immersed joint surface.

12. Calculations

12.1 *Joint Resistance*—Calculate the resistance, R_j , for the joint sample as follows:

$$R_j = 1000 A[(E_B - E_o)/E_s] \quad (1)$$

where

| | | |
|-------|---|--|
| R_j | = | resistance, Ω/ cm ² (Ω/ft ²), |
| A | = | immersed sample area (excluding end cap), cm ² (ft ²), |
| E_B | = | closed circuit potential of sample (reference Cu-CuSO ₄), V (switch closed), |
| E_o | = | open circuit potential of sample (reference Cu-CuSO ₄), V (switch open), and |
| E_s | = | voltage across 1000-Ω shunt resistor, V, (switch closed). |

13. Report

13.1 All test reports shall include the following:

13.1.1 Complete identification of the joint specimen including:

13.1.1.1 Name and code number of the base coating,

13.1.1.2 Thickness of the base coating,

13.1.1.3 Name and code number of the joint material, including type (that is tape, two-part mix, etc.),

13.1.1.4 Method of application of joint material, including amount of overlap.

13.1.1.5 Where applicable, the width and thickness of the joint material (tapes),

13.1.1.6 Where applicable, the name, code number, and type of primer,

13.1.1.7 Where applicable, the method of application of primer,

13.1.1.8 Average thickness of the joint material, as applied, and

13.1.1.9 Dates of starting and terminating the test and other information that may be pertinent.

13.2 The following readings shall be recorded on a periodic basis:

13.2.1 Voltage across the 1000-Ω shunt resistor, E_s ,

13.2.2 Closed-circuit potential of the joint specimen referenced to the Cu-CuSO₄ half cell, E_B ,

13.2.3 Open-circuit potential of the joint specimen referenced to the Cu-CuSO₄ half cell, E_o ,

13.2.4 Terminal voltage at the power supply, and

13.2.5 Calculated value of joint resistance, R_j ,

13.2.6 Initial series capacitance of the joint sample, and

13.2.7 Initial dissipation factor of the joint sample.

NOTE 5—The frequency of experimental readings will depend upon the performance of each joint specimen. Specimens that show a high rate of change may require more frequent watching if the point of failure is to be

recorded. Normally, weekly readings have been found to be adequate. Joint performance can be conveniently followed through plots of Joint Resistance versus Time and Dissipation Factor versus Time in semilogarithmic coordinates, and Capacitance Change versus Time in rectangular coordinates.

14. Precision

14.1 Due to the range of joint coating formulations, thicknesses, densities, etc. found among commercially available materials, the reproducibility⁴ of test results by these methods will tend to be poorer than those expected on straight runs of coated pipe. The fact that most joint materials are

⁴ The reproducibility of this test method is being determined and will be available on or before March 2009.

hand-applied introduces an inherent factor of variability into the test results. The basic purpose of these methods is to provide a means for the comparative screening of combinations of joint materials and base coatings for insulating effectiveness.

14.2 The precision (repeatability) of the joint resistance determination by these methods is considered to be such that when two tests are performed consecutively on the same specimen and under identical conditions of application, the difference between the two results may normally be expected not to exceed $\pm 10\%$ of their mean.

15. Keywords

15.1 capacitance; coating; current; dissipation factor; fittings; immersion; joint; leakage; patches; pipeline; resistance

ASTM International takes no position respecting the validity of any patent rights asserted in connection with any item mentioned in this standard. Users of this standard are expressly advised that determination of the validity of any such patent rights, and the risk of infringement of such rights, are entirely their own responsibility.

This standard is subject to revision at any time by the responsible technical committee and must be reviewed every five years and if not revised, either reapproved or withdrawn. Your comments are invited either for revision of this standard or for additional standards and should be addressed to ASTM International Headquarters. Your comments will receive careful consideration at a meeting of the responsible technical committee, which you may attend. If you feel that your comments have not received a fair hearing you should make your views known to the ASTM Committee on Standards, at the address shown below.

This standard is copyrighted by ASTM International, 100 Barr Harbor Drive, PO Box C700, West Conshohocken, PA 19428-2959, United States. Individual reprints (single or multiple copies) of this standard may be obtained by contacting ASTM at the above address or at 610-832-9585 (phone), 610-832-9555 (fax), or service@astm.org (e-mail); or through the ASTM website (www.astm.org). Permission rights to photocopy the standard may also be secured from the Copyright Clearance Center, 222 Rosewood Drive, Danvers, MA 01923, Tel: (978) 646-2600; <http://www.copyright.com/>