



Standard Test Method for Evaluating the Ignition Sensitivity and Fault Tolerance of Oxygen Pressure Regulators Used for Medical and Emergency Applications¹

This standard is issued under the fixed designation G175; the number immediately following the designation indicates the year of original adoption or, in the case of revision, the year of last revision. A number in parentheses indicates the year of last reapproval. A superscript epsilon (ϵ) indicates an editorial change since the last revision or reapproval.

1. Scope

1.1 For the purpose of this standard, a pressure regulator, also called a pressure-reducing valve, is a device intended for medical or emergency purposes that is used to convert a medical or emergency gas pressure from a high, variable pressure to a lower, more constant working pressure [21 CFR 868.2700 (a)]. Some of these oxygen pressure regulators are a combination of a pressure regulator and cylinder valve. These devices are often referred to as valve integrated pressure regulators, or VIPRs.

1.2 This standard provides an evaluation tool for determining the ignition sensitivity and fault tolerance of oxygen pressure regulators and VIPRs used for medical and emergency applications. An ignition-sensitive pressure regulator or VIPR is defined as having a high probability of ignition as evaluated by rapid pressurization testing (Phase 1). A fault-tolerant pressure regulator or VIPR is defined as having a low consequence of ignition as evaluated by forced ignition testing (Phase 2).

NOTE 1—It is essential that a risk assessment be carried out on breathing gas systems, especially concerning toxic product formation due to ignition or decomposition of nonmetallic materials as weighed against the risk of flammability (refer to Guide G63 and ISO 15001.2). See Appendix X1 and Appendix X2 for details.

1.3 This standard applies only to:

1.3.1 Oxygen pressure regulators used for medical and emergency applications that are designed and fitted with CGA 540 inlet connections, CGA 870 pin-index adapters (CGA V-1), or EN ISO 407 pin-index adapters.

1.3.2 Oxygen VIPRs used for medical and emergency applications that are designed to be permanently fitted to a medical gas cylinder.

1.4 This standard is a test standard not a design standard; *This test standard is not intended as a substitute for traditional*

design requirements for oxygen cylinder valves, pressure regulators and VIPRs. A well-designed pressure regulator or VIPR should consider the practices and materials in standards such as Guides G63, G88, G94, and G128, Practice G93, CGA E-18, CGA E-7, ISO 15001, ISO 10524-1 and ISO 10524-3.

NOTE 2—Medical applications include, but are not limited to, oxygen gas delivery in hospitals and home healthcare, and emergency applications including, but not limited to, oxygen gas delivery by emergency personnel.

1.5 This standard is also intended to aid those responsible for purchasing or using oxygen pressure regulators and VIPRs used for medical and emergency applications by ensuring that selected pressure regulators are tolerant of the ignition mechanisms that are normally active in oxygen systems.

1.6 This standard does not purport to address the ignition sensitivity and fault tolerance of an oxygen regulator or VIPR caused by contamination during field maintenance or use. Pressure regulator and VIPR designers and manufacturers should provide design safeguards to minimize the potential for contamination or its consequences (see Guide G88).

NOTE 3—Experience has shown that the use of bi-direction flow filters in components can lead to accumulation and re-release of contaminants (refer to Guide G88-05 Section 7.5.3.8 and EIGA Info 21/08).

1.7 The values stated in inch-pound units are to be regarded as standard. The values given in parentheses are mathematical conversions to SI units that are provided for information only and are not considered standard.

1.8 *This standard does not purport to address all of the safety concerns, if any, associated with its use. It is the responsibility of the user of this standard to establish appropriate safety and health practices and determine the applicability of regulatory limitations prior to use.*

2. Referenced Documents

2.1 ASTM Standards:²

¹ This test method is under the jurisdiction of ASTM Committee G04 on Compatibility and Sensitivity of Materials in Oxygen Enriched Atmospheres and is the direct responsibility of Subcommittee G04.01 on Test Methods.

Current edition approved Oct. 1, 2013. Published November 2013. Originally published as PS 127–00. Last published in 2011 as G175–03(2011). DOI: 10.1520/G0175-13.

² For referenced ASTM standards, visit the ASTM website, www.astm.org, or contact ASTM Customer Service at service@astm.org. For *Annual Book of ASTM Standards* volume information, refer to the standard's Document Summary page on the ASTM website.

- G63 Guide for Evaluating Nonmetallic Materials for Oxygen Service
- G88 Guide for Designing Systems for Oxygen Service
- G93 Practice for Cleaning Methods and Cleanliness Levels for Material and Equipment Used in Oxygen-Enriched Environments
- G94 Guide for Evaluating Metals for Oxygen Service
- G128 Guide for Control of Hazards and Risks in Oxygen Enriched Systems
- D618 Practice for Conditioning Plastics for Testing
- D4066 Classification System for Nylon Injection and Extrusion Materials (PA)
- D6779 Classification System for and Basis of Specification for Polyamide Molding and Extrusion Materials (PA)
- 2.2 *Other ASTM Documents:*²
- Manual 36 Safe Use of Oxygen and Oxygen Systems
Smith, S. R., and Stoltzfus, J. M., “Preliminary Results of ASTM G175 Interlaboratory Studies,” *Flammability and Sensitivity of Materials in Oxygen-Enriched Atmospheres: Tenth Volume, ASTM STP 1454*, T. A. Steinberg, H. D. Beeson, and B. E. Newton, Eds., ASTM International, West Conshohocken, PA, 2003.
- Smith, S. R., and Stoltzfus, J. M., “ASTM G175 Interlaboratory Study on Forced Ignition Testing,” *Journal of ASTM International*, Vol. 3, No. 7, Paper ID JAI13542, pp. 314-318.
- 2.3 *Compressed Gas Association (CGA) Standards:*³
- CGA E-4 Standard for Gas Pressure Regulators
- CGA E-7 Standard for Medical Pressure Regulators
- CGA E-18 Medical Gas Valve Integrated Pressure Regulators
- CGA G-4 Oxygen
- CGA G-4.1 Cleaning Equipment for Oxygen Service
- CGA V-1 American National/Compressed Gas Association Standard for Compressed Gas Cylinder Valve Outlet and Inlet Connections
- CGA V-14 Performance Standard for Sealing Gaskets Used on CGA 870 Connections for Medical Oxygen Service
- 2.4 *United States Pharmacopeial Convention Standard:*⁴
- USP 24 – NF 19 Oxygen monograph
- 2.5 *Federal Regulation:*⁵
- 21 CFR 868.2700 (a) Pressure regulator
- 2.6 *ISO Standards:*⁶
- ISO 10524-1 Pressure regulators for use with medical gases — Part 1: Pressure regulators and pressure regulators with flow-metering devices
- ISO 10524-3 Pressure regulators for use with medical gases — Part 3: Pressure regulators integrated with cylinder valves

- ISO 15001 Anaesthetic and respiratory equipment – Compatibility with oxygen
- 2.7 *European Industrial Gas Association Documents:*⁷
- EIGA Info 21/08 Cylinder Valves—Design Considerations

3. Summary of Test Method

3.1 This test method comprises two phases. A pressure regulator or VIPR must pass both phases in order to be considered ignition-resistant and fault-tolerant.

3.2 *Phase 1: Oxygen Pressure Shock Test*—In this test phase, the ignition sensitivity of the pressure regulator design is evaluated by subjecting the pressure regulator or VIPR to heat from oxygen pressure shocks. The test is performed according to ISO 10524–1 Section 6.6 for oxygen regulators, which is similar to CGA E-7 and ISO 10524–3 Section 6.6 for oxygen VIPRs.

3.3 *Phase 2: Promoted Ignition Test*—The Phase 1 component test system is used for Phase 2 to pressure shock a pressure regulator or VIPR so that an ignition pill is kindled to initiate combustion within the pressure regulator or VIPR. The ignition source is representative of severe, but realistic, service conditions.

3.3.1 *Oxygen Pressure Regulator*—In this test phase, and for this component type, fault tolerance is evaluated by subjecting the pressure regulator to the forced application of a positive ignition source at the pressure regulator inlet to simulate cylinder valve seat ignition and particle impact events.

3.3.2 *Oxygen VIPR*—In this test phase and for this component type, fault tolerance is evaluated by subjecting the VIPR to the forced application of a positive ignition source at the cylinder connection port to simulate a shut-off valve seat ignition and particle impact events in the use (not cylinder filling mode) configuration.

4. Significance and Use

4.1 This test method comprises two phases and is used to evaluate the ignition sensitivity and fault tolerance of oxygen pressure regulators used for medical and emergency applications.

4.2 *Phase 1: Oxygen Pressure Shock Test*—The objective of this test phase is to determine whether the heat or temperature from oxygen pressure shocks will result in burnout or visible heat damage to the internal parts of the pressure regulator.

4.2.1 The criteria for a valid test are specified in ISO 10524–1, Section 6.6 for oxygen pressure regulators and ISO 10524–3, Section 6.6 for oxygen VIPRs.

4.2.2 The pass/fail criteria for a pressure regulator are specified in ISO 10524–1, Section 6.6 for oxygen pressure regulators and ISO 10524–3, Section 6.6 for oxygen VIPRs.

4.3 *Phase 2: Promoted Ignition Test*—

4.3.1 *Oxygen Pressure Regulator*—The objective of this test phase is to determine if an ignition event upstream of the

³ Available from Compressed Gas Association (CGA), 4221 Walney Rd., 5th Floor, Chantilly, VA 20151-2923, <http://www.cganet.com>.

⁴ Available from U.S. Pharmacopeia (USP), 12601 Twinbrook Pkwy., Rockville, MD 20852.

⁵ Available from U.S. Government Printing Office Superintendent of Documents, 732 N. Capitol St., NW, Mail Stop: SDE, Washington, DC 20401, <http://www.access.gpo.gov>.

⁶ Available from International Organization for Standardization (ISO), 1, ch. de la Voie-Creuse, Case postale 56, CH-1211, Geneva 20, Switzerland, <http://www.iso.ch>.

⁷ Available from European Industrial Gas Association (EIGA), AISBL Avenue des Arts, 3-5-b-1210 Brussels, Belgium, <https://www.eiga.eu/>.

pressure regulator inlet filter will result in sustained combustion and burnout of the pressure regulator.

4.3.1.1 The criterion for a valid test is either, (1) failure of the pressure regulator, as defined in 4.3.1.2, or (2) if the pressure regulator does not fail, consumption of at least 90 % of the ignition pill as determined by visual inspection or mass determination.

4.3.1.2 Failure of the pressure regulator is defined as the breach of the pressurized regulator component (burnout), which may include the CGA 870 seal ring, and ejection of molten or burning metal or any parts, including the gauge, from the pressure regulator. See Appendix X6 Testing Pressure Regulators and VIPRs with Gauges. However, momentary (less than 1 s) ejection of flame through normal vent paths, with sparks that look similar to those from metal applied to a grinding wheel, is acceptable and does not constitute a failure.

4.3.2 *Oxygen VIPR*—The objective of this test is to determine if an ignition event upstream of the shut-off valve or within the shut-off valve will result in sustained combustion and burnout of the VIPR, while the VIPR is flowing oxygen in the patient-use direction.

4.3.2.1 The criterion for a valid test is either, (1) failure of the VIPR as defined in 4.3.2.2, or (2) if the VIPR does not fail, consumption of at least 90 % of the ignition pill as determined by visual inspection or mass determination. Although the intent and desired result is to provide sufficient energy to ignite the shut-off valve seat, ignition of the shut-off valve seat is not required for a valid test. See Rationale in Appendix X7.

4.3.2.2 Failure of the VIPR is defined as the breach of the pressurized VIPR component (burnout) and ejection of molten or burning metal or any parts, including the gauge, from the VIPR. See Appendix X6 Testing Pressure Regulators and VIPRs with Gauges. However, momentary (less than 1 s) ejection of flame through normal vent paths, with sparks that look similar to those from metal applied to a grinding wheel, is acceptable and does not constitute a failure.

4.3.3 There is no requirement that the oxygen pressure regulator or oxygen VIPR be functional after being subjected to the promoted ignition test.

NOTE 4—The criterion for both the pressure regulator and VIPR Phase 2 tests does not include evaluation of external hardware (such as plastic guards and bags) that could be subjected to a momentary ejection of flame through normal vent paths.

5. Apparatus

5.1 Both phases of this test shall be performed in a test system as specified by ISO 10524-1 and ISO 10524-3.

5.2 Fig. 1 depicts a schematic representation of a typical pneumatic impact test system that complies with ISO 10524-1 and ISO 10524-3.

5.3 The ambient temperature surrounding the pressure regulator or VIPR must be $70 \pm 9^\circ\text{F}$ ($21 \pm 5^\circ\text{C}$) for both phases of this test. For Phase 2 testing, the initial test gas temperature shall be $140 \pm 5.4^\circ\text{F}$ ($60 \pm 3^\circ\text{C}$).

6. Materials

6.1 For both phases of testing, the pressure regulator or VIPR shall be functional and in its normal delivery condition and shall be tested as supplied by the manufacturer. For further information, see Section 8.2.2.1 for pressure regulators and Section 8.2.3.1 for VIPRs. If a prototype or nonproduction unit is used to qualify the design, it shall be manufactured using design tolerances, materials, and processes consistent with a production unit. A possible total of eight pressure regulators or VIPRs will be tested: three in Phase 1 and five in Phase 2. If the test articles from Phase 1 are undamaged, they may be reassembled and used for Phase 2.

6.2 *Ignition Pill Manufacture and Assembly*—Follow these steps to manufacture and assemble the ignition pill used for Phase 2 testing. Use the materials listed in Table 1 to manufacture the ignition pills. The total required energy for the

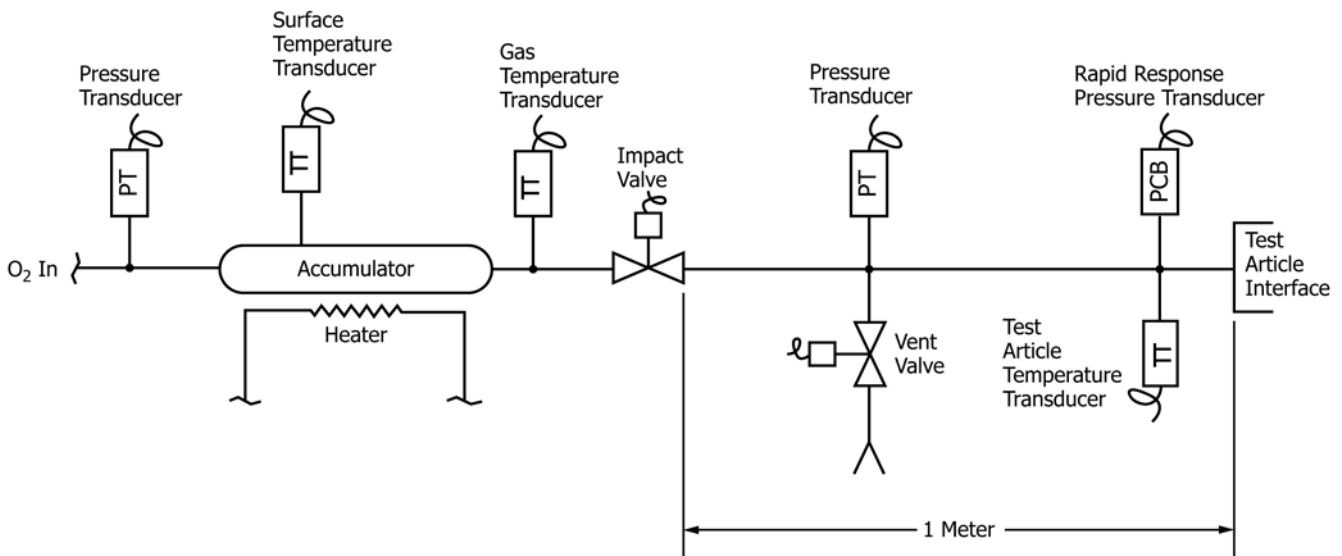

FIG. 1 Typical Test System Configuration

TABLE 1 Ignition Pill Materials and Characteristics

Materials for Phase 2 Ignition Pills (both 500 and 200 cal)	Standard or Specification	Representing Possible Source of Combustion Energy
Polyamide (PA66 or PA6) rod stock Polyamide (PA66 or PA6) sheet, 2 mil	D4066 or D6779, or both D4066 or D6779, or both	Cylinder valve seat or shut-off valve seat Cylinder valve stem lubricant or shut-off valve stem lubricant
Aluminum powder (325 mesh) Iron powder (325 mesh)	≥ 99.5% Al ≥ 99.5% Fe	Contaminant from cylinder Contaminant from cylinder

ignition pill is 500 ± 50 cal (2093 ± 209 J) for pressure regulators and 200 ± 20 cal (837 ± 84 J) for VIPRs. See Appendix X7, Development of 200 Cal Ignition Pill for VIPRs. The ignition pill casing consists of a cup and layers of sheeting. The cup and sheeting shall be constructed of polyamide (PA66 or PA6). Both the PA66 and PA6 shall be procured using the appropriate classification per Classifications D4066, or D6779, or both. This classification shall be documented and made part of the quality record.

NOTE 5—The ignition pill was developed to simulate both particle impact events and cylinder valve seat ignition. Particle impact events are simulated by iron/aluminum powder within the ignition pill. Nonmetallic promoters within the ignition pill simulate cylinder valve seat ignition for pressure regulators. The nonmetallic promoters are also used to bind and kindle ignition of the metallic powder and the shut-off valve seat for VIPRs.

6.2.1 Forming the Cup:

6.2.1.1 Turn the polyamide rod (see Table 1) down to $0.28 \pm 0/-0.0025$ in. ($7.11 \pm 0/-0.064$ mm) OD for the 500 cal pill and $0.188 \pm 0/-0.0025$ in. ($4.78 \pm 0/-0.064$ mm) OD for the 200 cal pill.

6.2.1.2 Place the rod in the brass sealing fixture (Fig. 2), sand the rod face flat, and remove any noticeable burrs.

NOTE 6—Fig. 3 shows the polyamide rod held in the sealing fixture for sanding.

6.2.1.3 Use a $3/16$ in. (4.76 mm) dia end mill to bore an ~ 0.06 in. (1.52 mm) deep cavity in the rod to form a cup for the 500 cal pill. Use a $5/32$ in. (3.97 mm) dia end mill to bore an ~ 0.025 in. (0.64 mm) deep cavity in the rod to form a cup for the 200 cal pill.

6.2.1.4 Cut the cup from the rod.

NOTE 7—The cup should be slightly taller than 0.13 in. (3.30 mm) for the 500 cal pill and slightly taller than 0.065 in. (1.65 mm) for the 200 cal pill. This is an initial pill height; the final pill height is achieved after sanding and is based on the required final pill weight.

6.2.1.5 Using a #69 drill, drill a hole completely through the center of the bottom of the cup. If necessary, square the bottom of the cup with a file to ensure it sits flat and will not tip over.

NOTE 8—The pill base and dimensions are shown in Fig. 4 and Fig. 18 for the 500 and 200 cal pills, respectively.

6.2.2 Sealing the Bottom of the Cup:

6.2.2.1 Put the cup and polyamide push tool (Fig. 5) into the brass sealing fixture and adjust the push tool so that the top of the cup is just slightly below the surface of the sealing fixture.

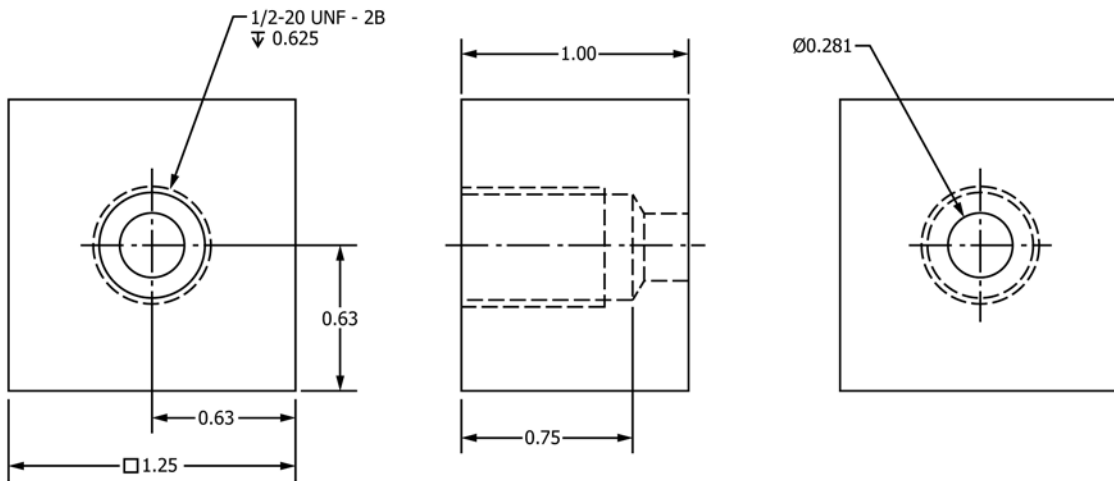

- Notes:
 1. Material: Brass (UNS C36000)
 2. 1 inch = 25.4 mm

UNLESS OTHERWISE SPECIFIED			
DIMENSIONS ARE IN INCHES			
.X	.XX	.XXX	ANGLE
± .1	± .010	± .005	± 1/2°
DIMENSIONING & TOLERANCING PER ANSI Y14.5M-1994			

FIG. 2 Brass Sealing Fixture

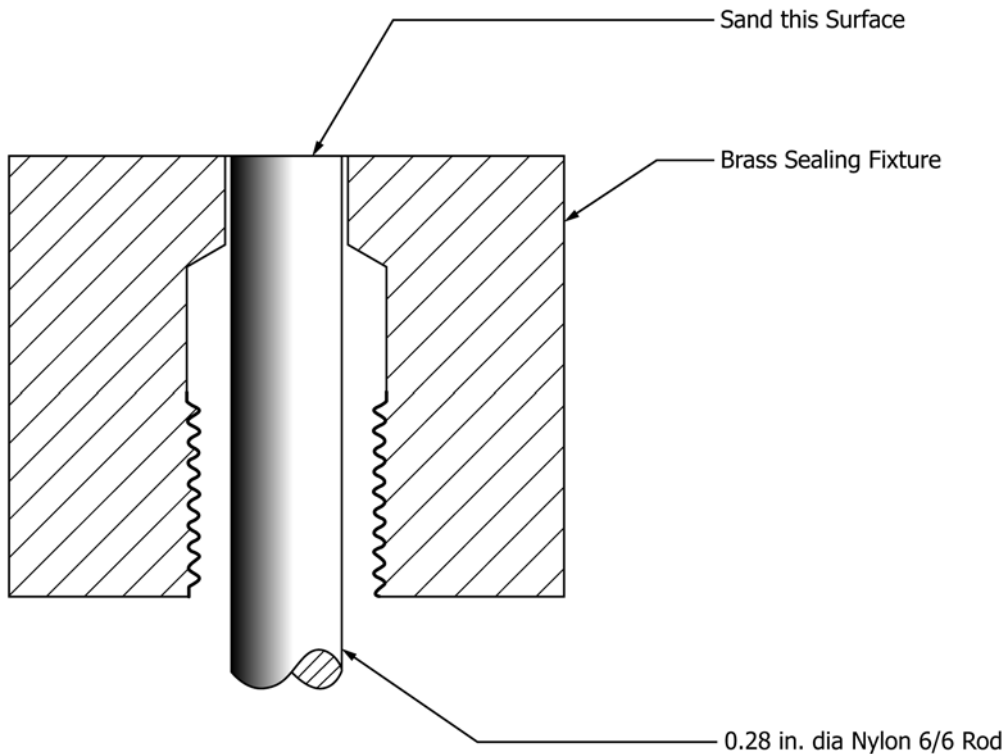

FIG. 3 Polyamide Rod in Sealing Fixture

NOTE 9—If the top of the cup is not situated in the sealing fixture just slightly below the surface, the heat of the soldering iron could deform the top of the cup.

6.2.2.2 Place one layer of polyamide sheet in the bottom of the cup and cover it with polyimide tape (PI), with the adhesive side facing away from the pill.

NOTE 10—The PI tape is used as a mold release and does not remain attached to the final pill. If the adhesive side faces the pill, it will add an undesired residue to the pill. The recommended PI tape for mold release is a 1 mil (25.4 micron) PI film with a single side coat of acrylic adhesive.

6.2.2.3 Seal the polyamide to the bottom of the cup using a soldering iron tip (Fig. 6). Ensure that heat is applied evenly around the perimeter of the inside cup bottom so as to melt the polyamide sheet to the bottom of the cup.

NOTE 11—The soldering iron temperature should be approximately 450°F (232°C).

6.2.2.4 Remove the PI tape and the remaining polyamide sheet.

NOTE 12—The polyamide sheet should easily tear away from the bottom of the cup, leaving a disc of polyamide sealed to the bottom of the cup. If it does not, the ignition pill has not been sealed properly, and the procedure should be repeated.

6.2.3 Filling the Cup:

6.2.3.1 Place the cup on a scale capable of resolution to 0.1 mg and zero the scale.

6.2.3.2 For the 500 cal pill, add 10 ± 1 mg aluminum powder and 3 ± 1 mg iron powder to the cup. For the 200 cal pill, add 6 ± 1 mg aluminum powder and 3 ± 1 mg iron powder to the cup. Put the aluminum powder in the cup first, then the iron.

NOTE 13—If too much iron is added to the pill, a magnetic spatula may be used to remove iron from the cup.

6.2.3.3 After filling the cup, push any metallic powder on the top surface of the cup into the cup.

NOTE 14—A small paintbrush can be used for this purpose. This is a critical step in making the pill, and it is important to ensure that no material remains on the surface to inhibit a proper heat seal.

6.2.4 Sealing the Cup:

6.2.4.1 Put the cup and the polyamide push tool into the brass sealing fixture and adjust the push tool so that the top of the cup is just slightly below the surface of the sealing fixture.

NOTE 15—If the top of the cup is not situated in the sealing fixture just slightly below the surface, the heat of the soldering iron could deform the top of the cup.

6.2.4.2 Place one layer of polyamide sheet over the top of the cup, then cover the polyamide sheet with PI tape.

6.2.4.3 Place a copper seal tip (Fig. 7) onto the tip of the soldering iron.

NOTE 16—The copper seal tip temperature should be approximately 450°F (232°C).

6.2.4.4 Hold the soldering iron perpendicular to the top of the cup, rotate the soldering iron slightly, and apply heat until the polyamide sheet is sealed to the top of the cup (Fig. 8). Let the cup cool for ~1 min before removing the remaining polyamide sheet and PI tape. Repeat this process until the cup is capped with five layers of polyamide sheet (Fig. 9).

NOTE 17—If the cup is sealed properly, a disc of the polyamide sheet will be sealed to it and the remainder of the sheet will easily pull off. It is especially critical to ensure the first layer of polyamide sheet is completely

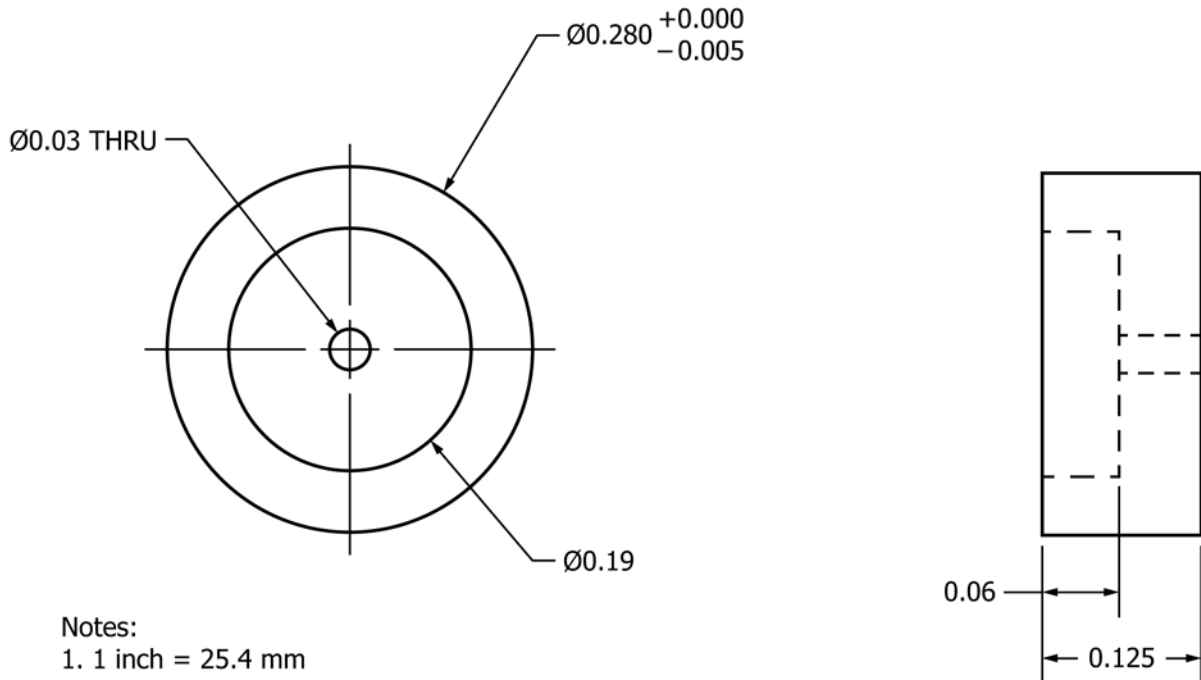

Notes:
1. 1 inch = 25.4 mm

UNLESS OTHERWISE SPECIFIED			
DIMENSIONS ARE IN INCHES			
.X	.XX	.XXX	ANGLE
$\pm .1$	$\pm .010$	$\pm .005$	$\pm 1/2^\circ$
DIMENSIONING & TOLERANCING PER ANSI Y14.5M-1994			

FIG. 4 Pill Base (500 cal)

sealed to the top of the cup, or else the pill contents will leak out and render the pill unusable.

6.2.4.5 Once the pill is properly sealed and cooled, remove it from the brass sealing fixture. Place the pill upside down in the sealing fixture so that the pill bottom is exposed.

NOTE 18—Take care to ensure that the pill is properly squared in the fixture so that it can be properly sanded. If the pill is not squared in the sealing fixture, the cup bottom can be sanded open, thus exposing the metallic powder and ruining the pill.

6.2.4.6 Using a belt or palm sander, sand the pill until a final weight of 67 ± 1 mg and 29 ± 1 mg is achieved for the 500 and 200 cal pills, respectively. Use the push tool to remove the pill from the sealing fixture.

6.2.5 *Storing the Pill*—The manufactured pills shall be stored in a dry atmosphere (e.g. in a desiccant container or in a sealed bag with a desiccant) for a minimum of 24 hours prior to use. Conditioning at 24/23/0 per Guide D618 has been shown to yield successful results for the polyamide materials in this application.

6.3 *Adapter Block and Pill Holder Manufacture*—Adapter blocks and pill holders for pressure regulators with CGA 540 inlet connections shall be made according to the drawings

shown in Figs. 10 and 11. An alternative CGA 540 adaptor block and pill holder is provided in Fig. X4.1 and Fig. X4.2. Adapter blocks and pill holders, adapter couplings and pill retainers for VIPRs shall be made according to the drawings shown in Figs. 12 and 13. Pill holders, adapter couplings and pill retainers for VIPRs shall be made according to the drawings shown in Fig. 16, Fig. 17, Fig. 19 and Fig. 20. All adapter blocks, pill holders, adapter couplings and pill retainers shall be constructed of Brass UNS C36000.

6.4 For Phase 1 testing, the minimum oxygen concentration shall be of 99.5 % purity and shall not contain more than 10 ppm hydrocarbons. For Phase 2 testing, the minimum oxygen concentration shall conform to USP 24-NF 19, Type 1, or shall be of 99.0 % purity. Oxygen of higher purity may be used, if desired.

7. Safety Precautions

7.1 This test can be hazardous. The test cell shall be constructed of fire- and shrapnel-resistant materials in a manner that shall provide protection from the effects of test system component rupture or fire that could result from test article reaction or failure of a test system component. Normal safety

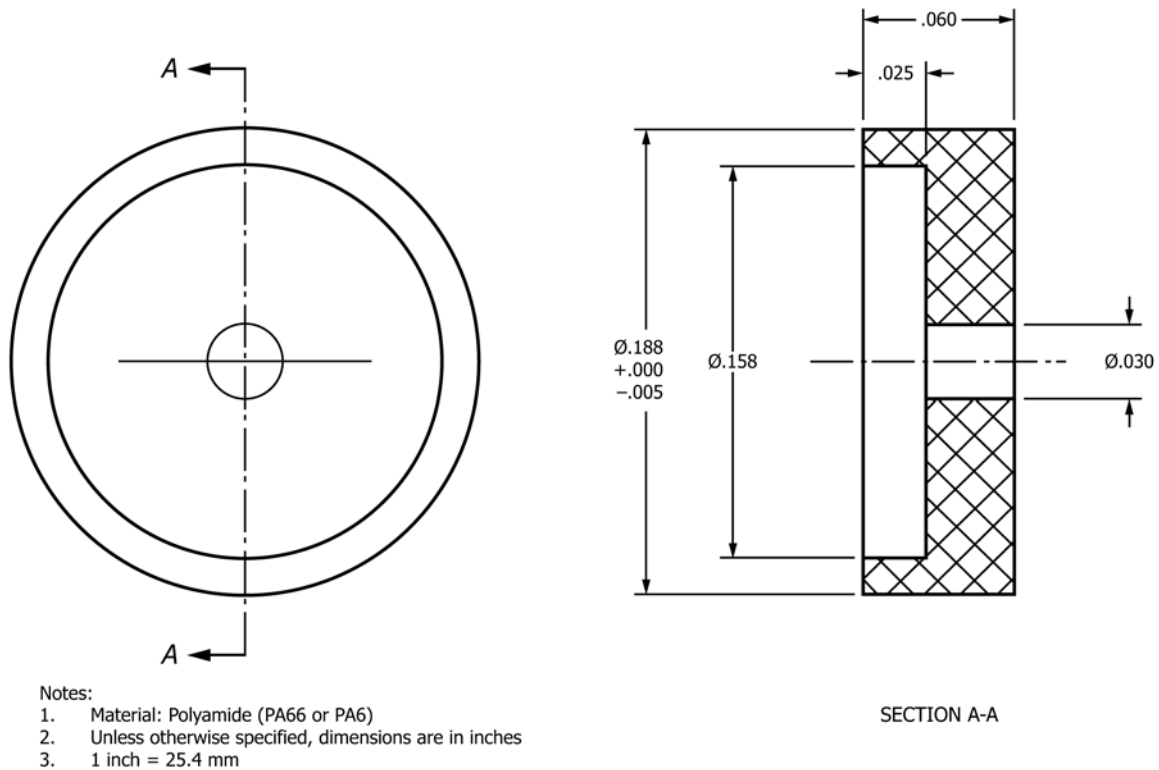

FIG. 18 VIPR Pill Base (200 Cal)

precautions applicable to the operation and maintenance of high-pressure gas systems shall be followed when working with the test system.

7.1.1 Complete isolation of personnel from the test system is required whenever the test cell contains a test article and is pressurized above atmospheric pressure with oxygen. Violent reactions between test articles and high-pressure oxygen must be expected at all times. Test cell component failure caused by violent test article reaction has produced shrapnel, flying ejecta, dense smoke, and high-pressure gas jets and flames inside the test cell. Test cell design and layout, test procedures, personnel access controls, and emergency shutdown procedures shall be designed with this type of failure expected at any time the test system contains oxygen.

7.1.2 Complete isolation can be assured by locating the test apparatus in an enclosure and behind a barricade. The operator should be stationed in a control room opposite the barricade from the test cell. Visual observation of the test cell shall be accomplished by an indirect means such as a periscope, mirrors, or closed-circuit television.

7.1.3 Equipment used in a high-pressure oxygen system shall be properly designed and rated for oxygen service. Proper design of high-pressure oxygen systems includes designing for minimum internal volumes, thereby limiting the magnitude of catastrophic reactions that may occur while testing a pressure regulator or VIPR. Components used in the test system, such as valves, pressure regulators, gauges, filters, and the like shall be fabricated from materials that have a proven record of suitability for high-pressure oxygen service. Examples of such materials are Monel 400, nickel, and selected stainless steels.

7.1.3.1 High-pressure oxygen systems require the utmost cleanliness (see Practice G93). Therefore, test system components should be designed to facilitate disassembly, thorough cleaning, and reassembly without compromise of the cleanliness level. Screening tests performed on nonmetallic materials have shown that the impact sensitivity of these materials can vary from batch to batch. Because nonmetallic materials are usually the most easily ignited components in a high-pressure oxygen system, nonmetallic items to be used in this test apparatus such as seats, seals, and gaskets should be chosen from the best (that is, least sensitive) available batch of material. Preferably, two valves should be provided between the high-pressure oxygen source and the test article interface. These valves shall be closed, and the test cell and the volume between the two valves shall be continuously vented to atmospheric pressure, before personnel perform work on the test article.

7.2 When testing is to be performed at an elevated temperature, normal safety precautions applicable to the operation and maintenance of electrical systems shall be followed.

7.3 **Caution:** Approved eye protection shall be worn in the test area at all times. Other protective equipment such as gloves and ear protection shall be required if the system vent is adjacent to the test system or if the audible levels are expected to be greater than the OSHA limits.

7.4 No personnel shall be permitted in the test cell when remotely controlled valves are operated or when testing is in progress.

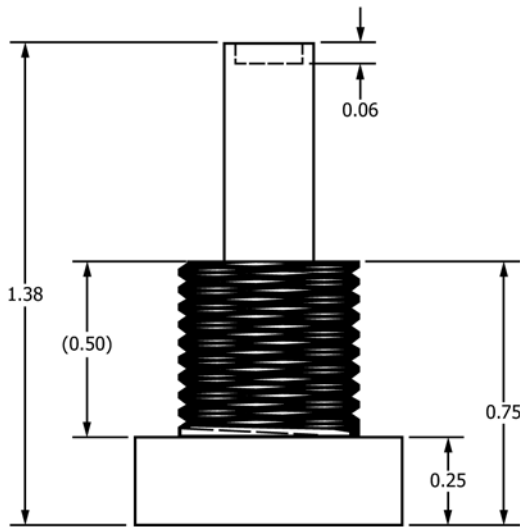
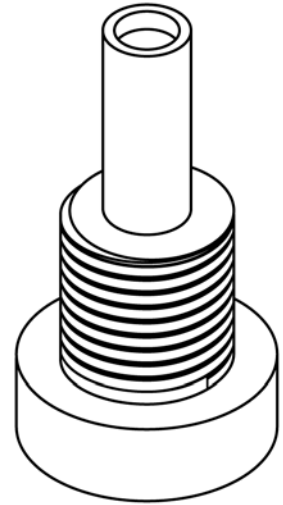
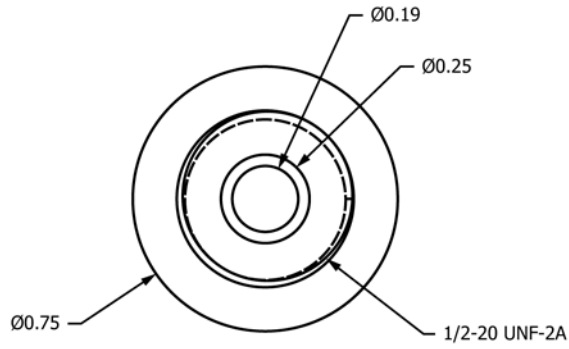

- Notes:
 1. Material: Nylon 6/6
 2. 1 inch = 25.4 mm

UNLESS OTHERWISE SPECIFIED			
DIMENSIONS ARE IN INCHES			
.X	.XX	.XXX	ANGLE
$\pm .1$	$\pm .010$	$\pm .005$	$\pm 1/2^\circ$
DIMENSIONING & TOLERANCING PER ANSI Y14.5M-1994			

FIG. 5 Polyamide Push Tool

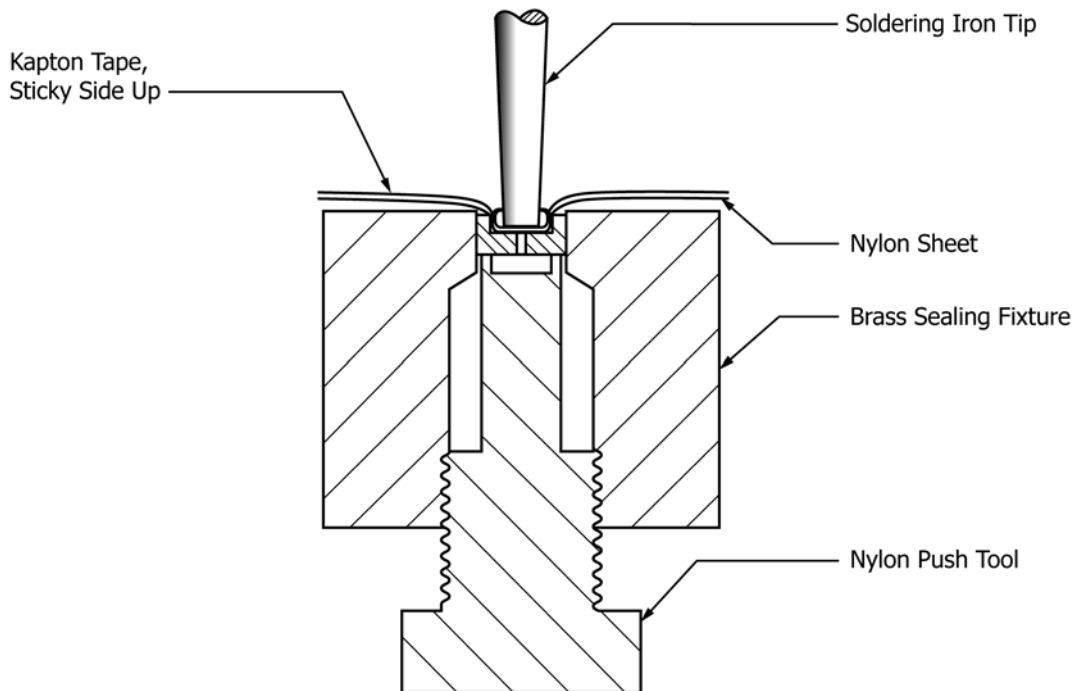
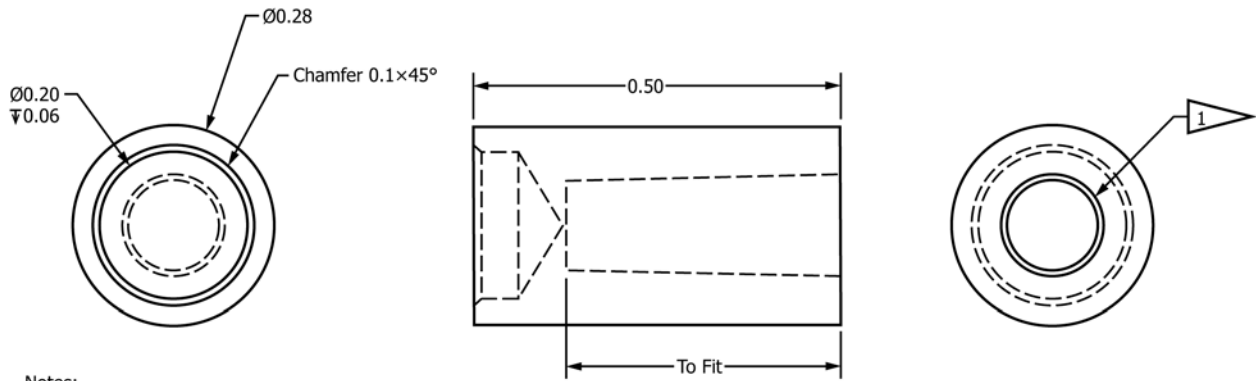

FIG. 6 Sealing the Bottom of the Cup



- Notes:
 1. Material: Copper
 2. 1 inch = 25.4 mm

UNLESS OTHERWISE SPECIFIED			
DIMENSIONS ARE IN INCHES			
.X	.XX	.XXX	ANGLE
± .1	± .010	± .005	± 1/2°

DIMENSIONING & TOLERANCING PER
ANSI Y14.5M-1994

1 Construct mating hole to provide max. contact area with soldering iron tip to provide max. heat transfer to seal tip.

FIG. 7 Copper Seal Tip

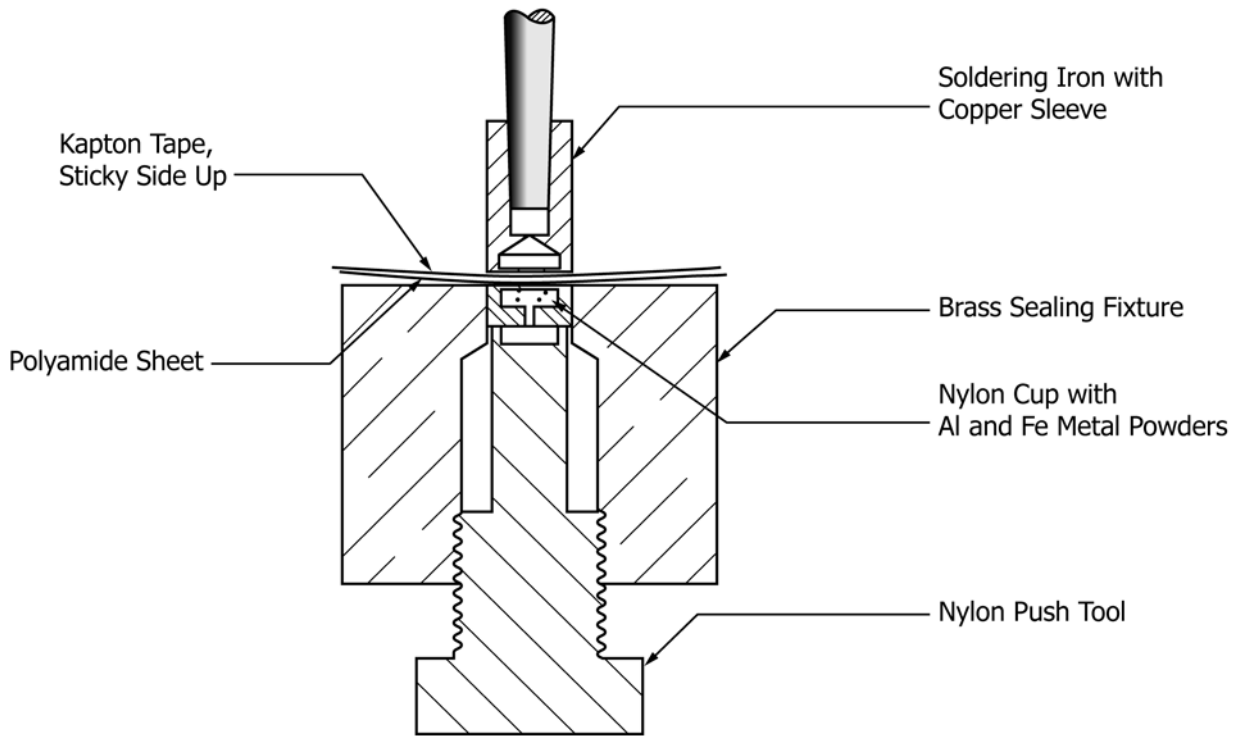

FIG. 8 Sealing the Top of the Pill

7.5 The test area shall be maintained safe and clean.

7.6 **Warning:** Oxygen vigorously accelerates combustion. Keep oil and grease away. Do not use oil or grease on test system valves, pressure regulators, gauges, or control equipment. Use only equipment conditioned for oxygen service by carefully cleaning to remove oil, grease, and other combustibles. Keep combustibles away from oxygen and eliminate ignition sources. Keep surfaces clean to prevent ignition or explosion, or both, on contact with oxygen. Always use a

pressure regulator to reduce the pressure where possible. Fully reduce the test system pressure regulator (set this regulator to deliver a pressure of 0) before opening the cylinder valve(s). All equipment and containers used shall be suitable and recommended for oxygen service. Never attempt to transfer oxygen from a cylinder in which it is received to any other cylinder. Do not mix gases in cylinders. Do not drop cylinders. Make sure cylinders are secured and positioned upright at all times. Keep the cylinder valve(s) closed when not in use. Stand

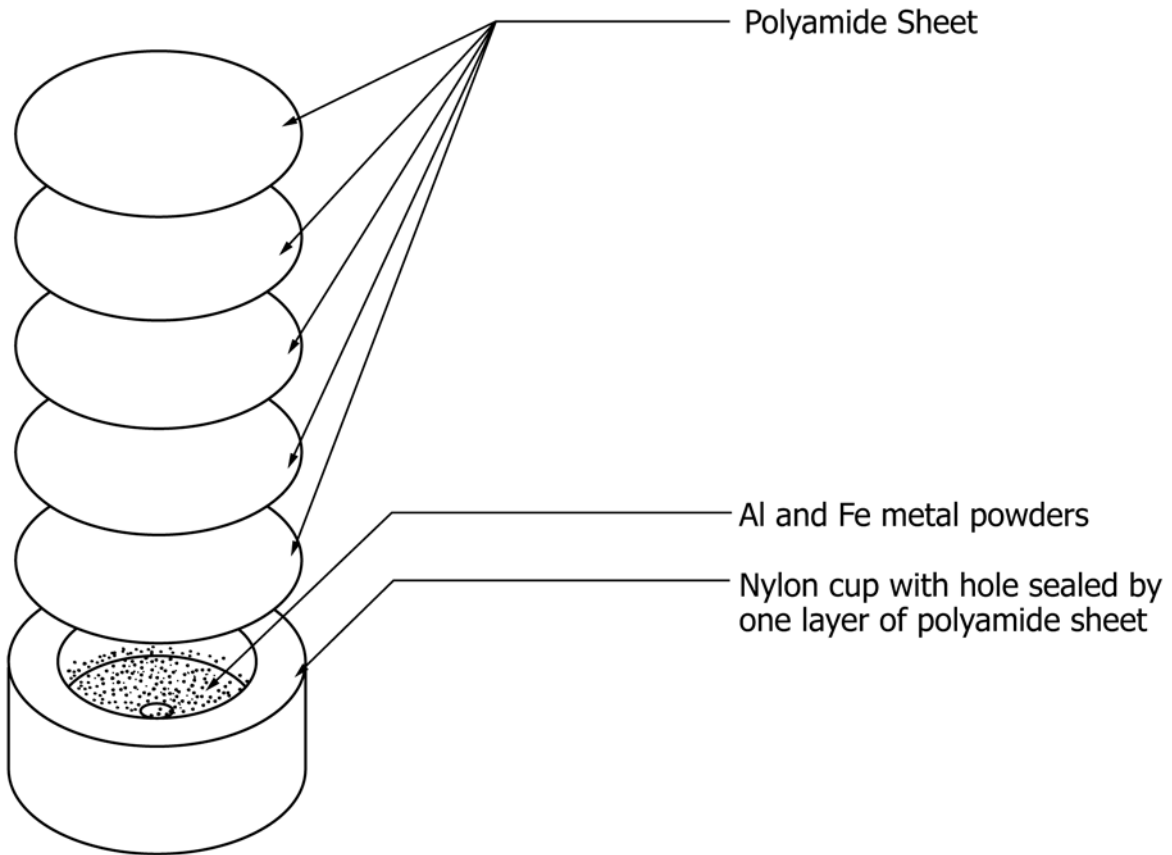

FIG. 9 Five Layers of Polyamide Used to Seal Pill

away from the cylinder valve outlet when opening a cylinder valve. Keep cylinders out of the sun and away from heat. Keep cylinders away from corrosive environments. Do not use unlabeled, dented, or damaged cylinders.

7.7 See Guides G63, G88, Practice G93, Guides G94, G128 and Compressed Gas Association publications G-4 and G-4.1 for additional information regarding safe practice in the use of oxygen.

8. Procedure

8.1 Phase 1: Oxygen Pressure Shock Test—

8.1.1 Phase 1 is performed according to ISO 10524-1 Section 6.6 for oxygen pressure regulators.

8.1.2 Phase 1 is performed according to ISO 10524-3 Section 6.6 for oxygen VIPRs.

8.2 Phase 2: Promoted Ignition Test—

8.2.1 *Installing the Pill*—Use gloves and clean handling techniques when handling the pill, adapter block, pill holder, and test article. Use a 500 ± 50 cal (2093 \pm 209 J) pill for pressure regulators and 200 ± 20 cal (837 \pm 84 J) pill for VIPRs. Using the copper seal tip (Fig. 7), press the 500 cal ignition pill, polyamide sheet-side up, into the threaded end of the pill holder for pressure regulators. Press the 200 cal ignition pill polyamide sheet-side down for VIPRs so the sheet-side faces upstream. Ensure that the pill fits snugly in the pill holder, or it may not ignite. Install the pill holder into the adapter blocks for pressure regulators (Fig. 14 and Fig. 15).

Install the pill retainer (Fig. 19) to help retain the pill in the pill holder for VIPRs and install the pill holder into the adapter coupling (Fig. 20).

8.2.2 *Oxygen Pressure Regulator*—Phase 2 tests five functional pressure regulators in normal delivery condition at an initial minimum pressure of 2200 ± 50 psi (15.2 \pm 0.34 MPa) or the nominal inlet pressure (see definition in ISO 10524-1). All five pressure regulators must pass for the pressure regulator to be considered fault tolerant. See Appendix X3 Test Pressure Rationale.

8.2.2.1 Test the pressure regulator in the condition supplied by the manufacturer. If the pressure regulator is supplied with a filter, perform the Phase 2 test with the filter installed. Set the pressure regulator flow or pressure setting, if applicable, to mid-range. For those pressure regulators possessing a CGA 870 connection, carefully inspect both mating surfaces for the seal ring. If any possibility of leakage exists, repair the surfaces. Place the seal around the inlet fitting. Carefully mate the pressure regulator to the CGA 870 or 540 adapter block. Using a torque wrench, apply sufficient mating pressure to the sealing surfaces to ensure that there is no leakage at the seal and that the pressure regulator will stay bound to the adapter fitting during pneumatic impact. Install the adapter block and pressure regulator into the test system (Figs. 14 and 15).

NOTE 19—A torque specification for mating the CGA 870 adapter block to the pressure regulator is not available. Labs that have performed this test have torqued this connection in the range of 15 to 60 in.-lb (1.7 to 6.8 Nm). The intention of this instruction is to ensure that there is no leakage

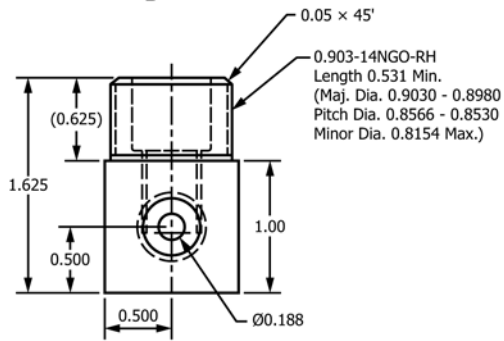
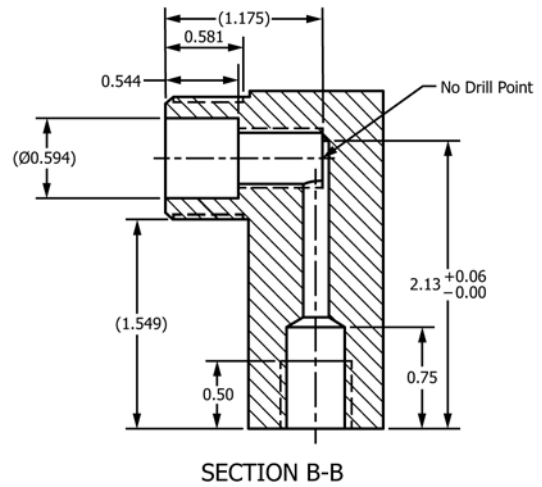
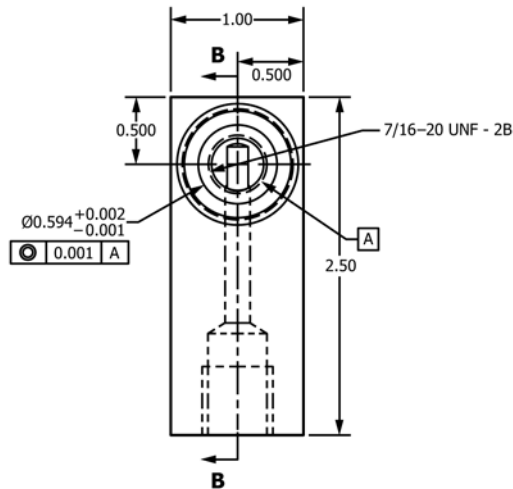

- Notes:
1. Material: Brass (UNS C36000)
 2. Break all sharp edges
 3. 1 inch = 25.4 mm

UNLESS OTHERWISE SPECIFIED			
DIMENSIONS ARE IN INCHES			
X	XX	XXX	ANGLE
±.1	±.010	±.005	±1/2°
DIMENSIONING & TOLERANCING PER ANSI Y14.5M-1994			

FIG. 10 CGA 540 Adapter Block

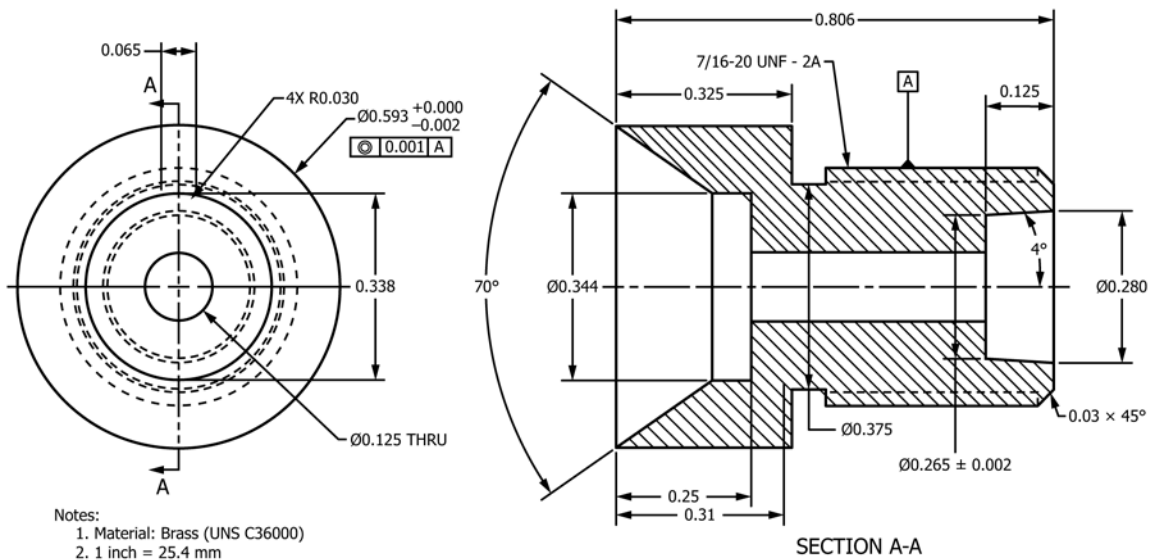

- Notes:
1. Material: Brass (UNS C36000)
 2. 1 inch = 25.4 mm

UNLESS OTHERWISE SPECIFIED			
DIMENSIONS ARE IN INCHES			
.X	.XX	.XXX	ANGLE
±.1	±.010	±.005	±1/2°
DIMENSIONING & TOLERANCING PER ANSI Y14.5M-1994			

FIG. 11 CGA 540 Adapter Pill Holder

between the adapter block and the pressure regulator seal ring. See CGA V-14.

NOTE 20—Leakage between the pressure regulator and CGA 870 or 540 adapter block may prevent the apparatus from providing the proper heat of

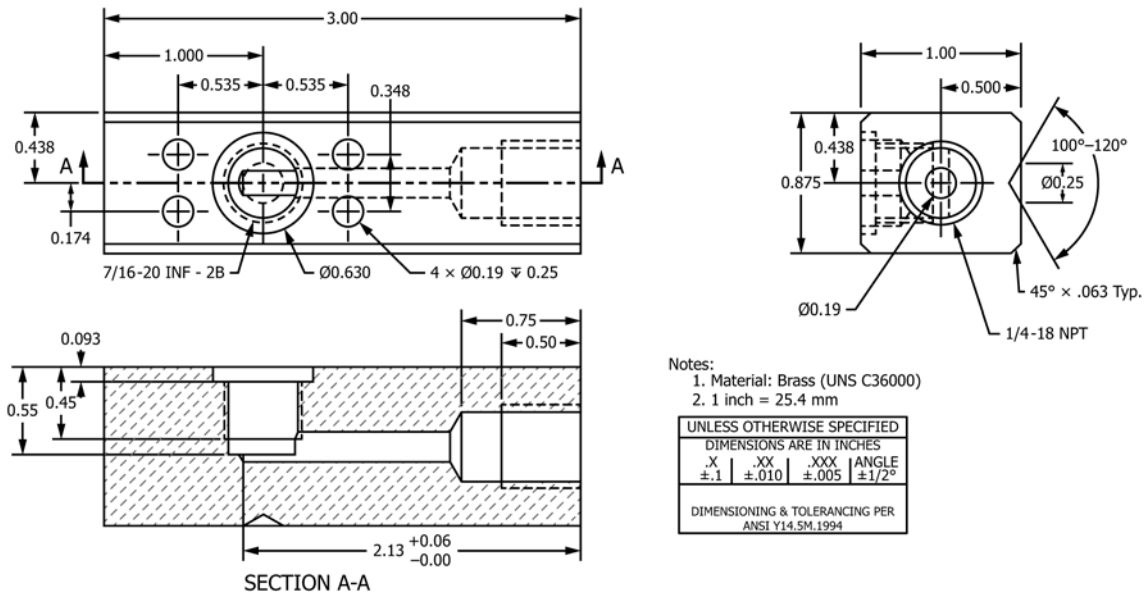

FIG. 12 CGA 870 Adapter Block

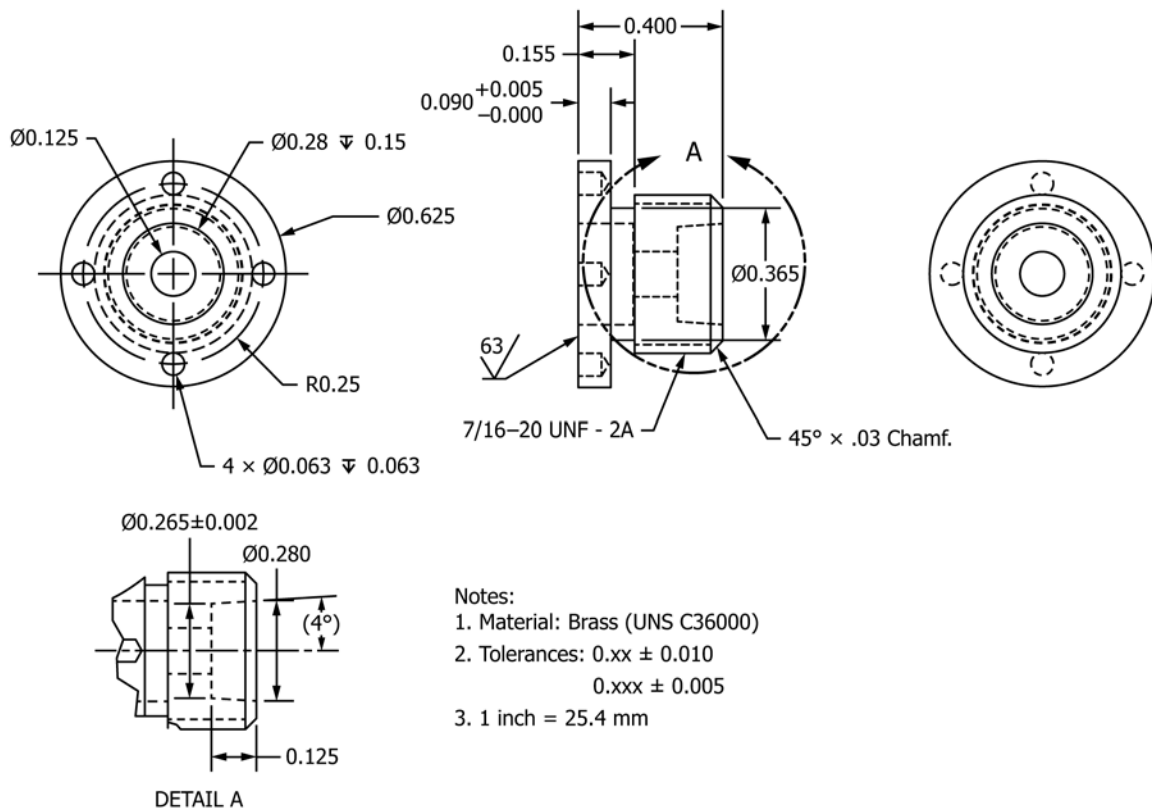

FIG. 13 CGA 870 Adapter Pill Holder

compression for pill ignition and therefore invalidate the test.

8.2.3 *Oxygen VIPR*—Phase 2 tests five functional VIPRs in normal delivery condition at 1.2 × the nominal inlet pressure, as defined by ISO 10524-3. All five VIPRs must pass for the VIPR regulator to be considered fault-tolerant.

8.2.3.1 *Testing in the Patient-Use Mode*—Test VIPR with the pressure regulator portion set to mid-range flow or pressure setting. Position the ignition pill at the inlet (cylinder) connection of VIPR so that the flow of the fire is consistent with the flow of the gas during normal patient use of the VIPR. The

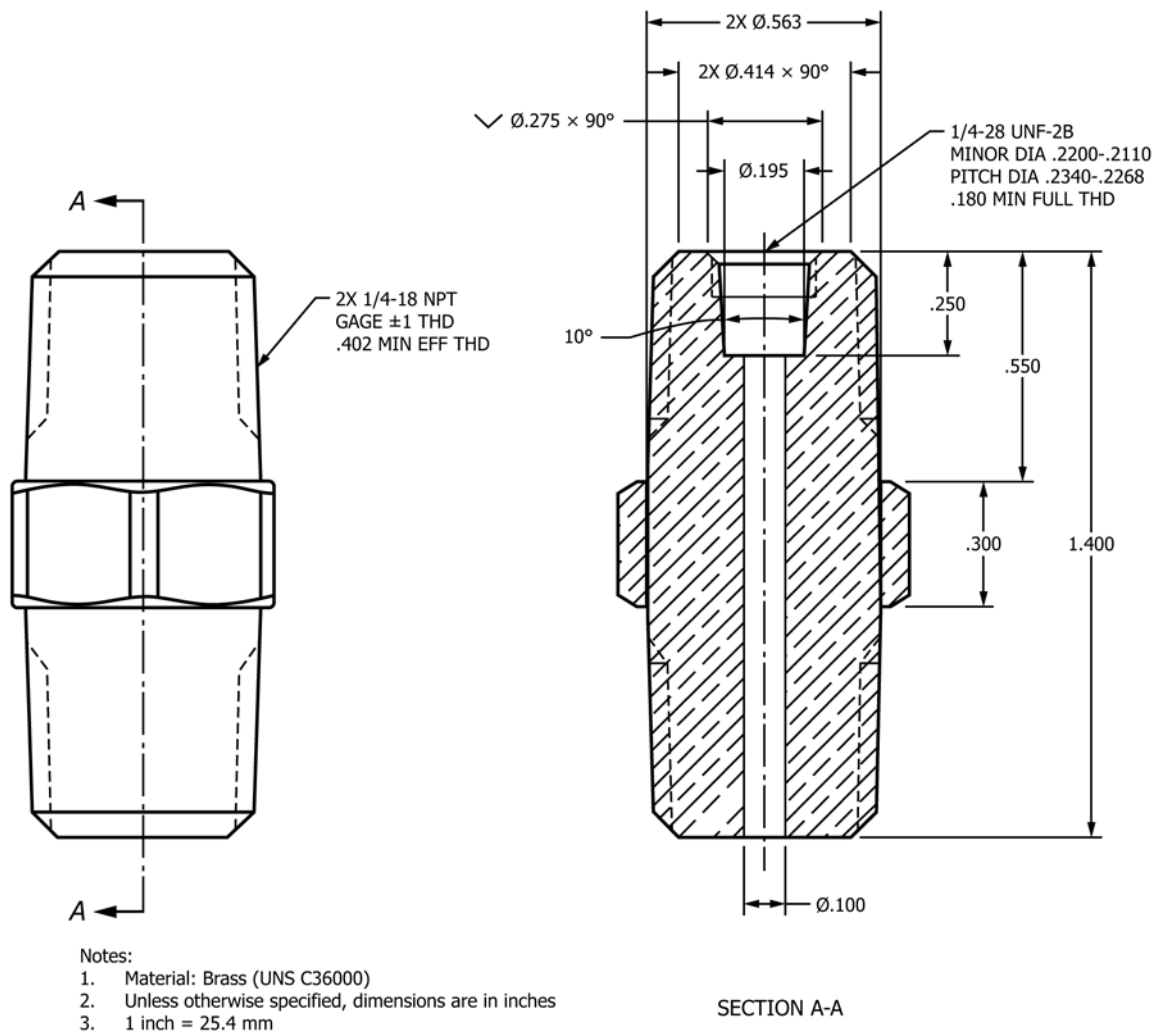

FIG. 16 VIPR Adapter Pill Holder

shut-off valve (shown as Part 2 – means of gas shut-off in Figures 4 and 5 of ISO 10524-3 Section 6.6) should be set fully opened. If the VIPR design exhibits a flow-impinging feature upstream of the shut-off valve at the inlet (cylinder) connection (e.g., flow restriction device, dip tube, filter (see Note 21), residual pressure valve), then this shall be removed by the manufacturer for testing to allow attachment of the adapter block to the inlet (cylinder) connection of the VIPR (shown as Part 1 – valve stem in Figures 4 and 5 of ISO 10524-3 Section 6.6) and to direct the energy of the pill ignition towards the shut-off valve seat (see Note 22). If the VIPR does not include a shut-off valve (shown as Part 2 – means of gas shut-off in Figures 4 and 5 of ISO 10524-3 Section 6.6) then this Patient-Use Mode test is still required. Install the assembled pill, adapter coupling, pill holder, pill retainer, and VIPR to the pneumatic impact test system (Fig. 18).

NOTE 21—Experience has shown that the use of bi-direction flow filters in components can lead to accumulation and re-release of contaminants (refer to Practice G88 Section 7.5.3.8 and EIGA Info 21/08.)

NOTE 22—This test standard does not require that these flow-impinging features be not included in the final design of the VIPR. Instead, this standard is requiring that these features be removed only for this test method so that the shut-off valve seat is ignited by the ignition pill

combustion energy and that the objective of the test is achieved. No viable method of dependably igniting the shut-off valve seat with these features included was identified. Igniting the ignition pill at the inlet (cylinder) connection of the VIPR was considered the most viable method but this requires the removal of flow-impinging features to be an effective test method. This test method is not evaluating the performance or the effectiveness of these flow-impinging features to quench a fire originating from the cylinder connection since this type of fire is not expected in use. This standard requires that these features be removed only to effectively ignite the shut-off valve seat by this Phase 2 test method. All other performance/type testing, including Phase 1, should include these features if they are part of the final VIPR design.

8.2.4 *System Purge*—Before testing, purge the test system by slowly pressurizing the volume upstream of the pill with gaseous oxygen (approximately 200 psig [1.38 MPa]), then vent slowly to ambient to empty this volume.

NOTE 23—Fast pressurization or vent rates during the system purge could ignite or dislodge the pill.

8.2.5 *Securing the Piping System*—At a minimum, securely fasten the supply system as close as possible to the test article.

NOTE 24—Because burnout of the test article is possible, special precautions must be taken to ensure the safety of personnel and equipment. When part of the pressure regulator or VIPR body is burned away,

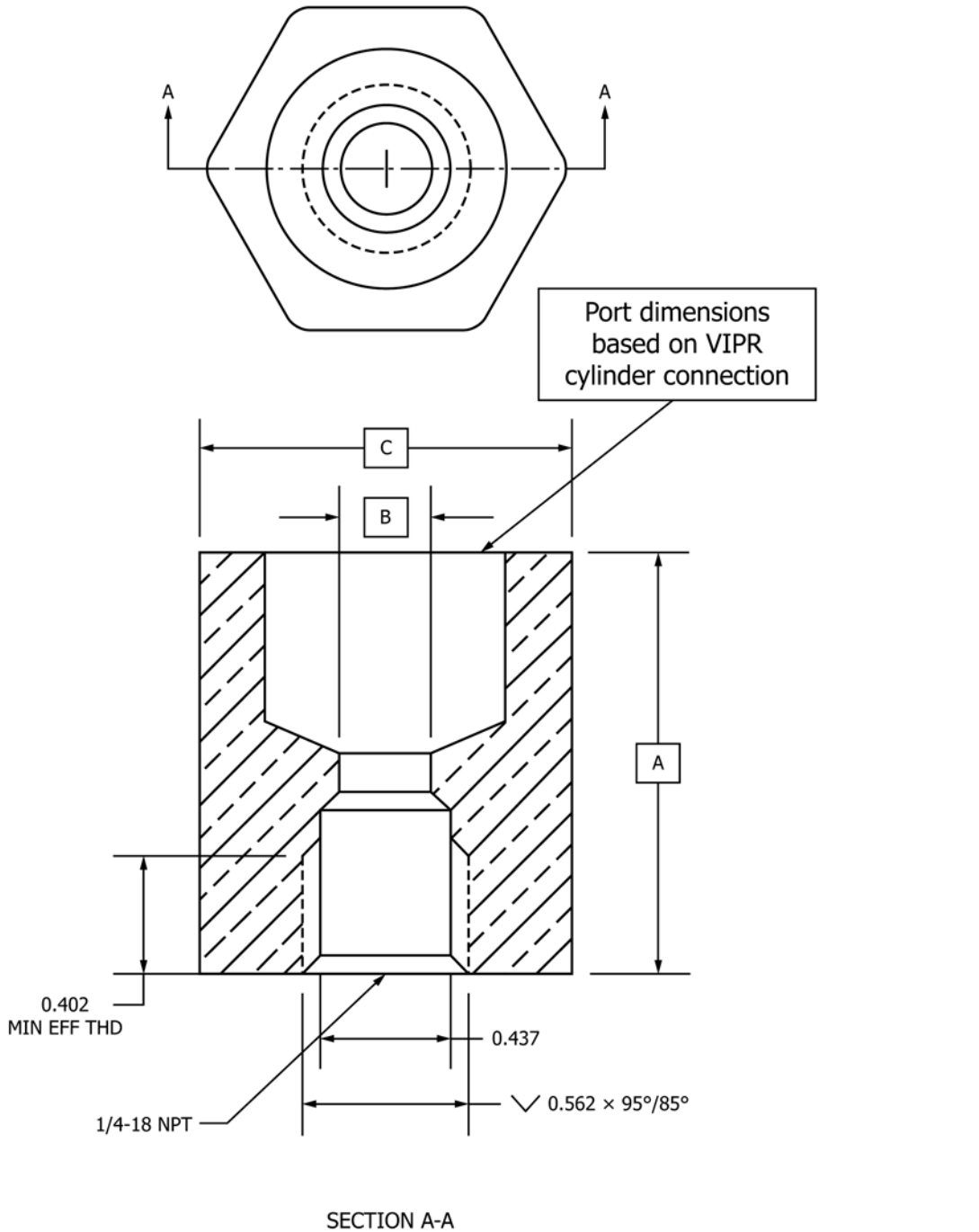

Notes:

1. Material: Brass (UNS C36000)
2. Unless otherwise specified, dimensions are in inches
3. 1 inch = 25.4 mm

Dimensions:

- A: Undefined. See Dimension D in FIG. 20.
- B: 0.18 to 0.45 inches (4.6 to 11.4 mm)
- C: Maximum 2.5 inches (63.5 mm)

FIG. 17 VIPR Adapter Coupling

much more jet force is possible than would normally be expected from an intact device. The direction and magnitude of the force generated is unpredictable. Also, precautions against flying debris should be implemented because whole test articles can be ejected. The “cutting torch” action of these fires is another hazard that weakens normally sufficient anchorages.

8.2.6 *Video recording*—A video recording should be made of the test article during testing and reviewed. A camera with a minimum 25 frame-per-second speed shall be used to capture an ejection event that may be missed by the naked eye. Usually one view is sufficient to capture ejection events from any angle.

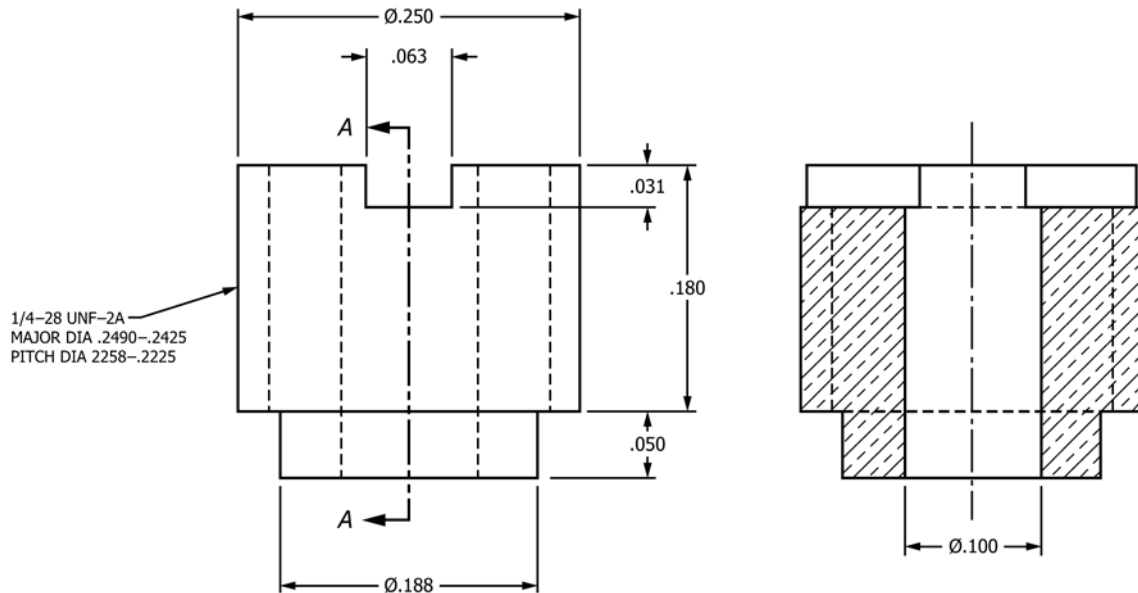

- Notes:
1. Material: Brass (UNS C36000)
 2. Unless otherwise specified, dimensions are in inches
 3. 1 inch = 25.4 mm

FIG. 19 VIPR Pill Retainer

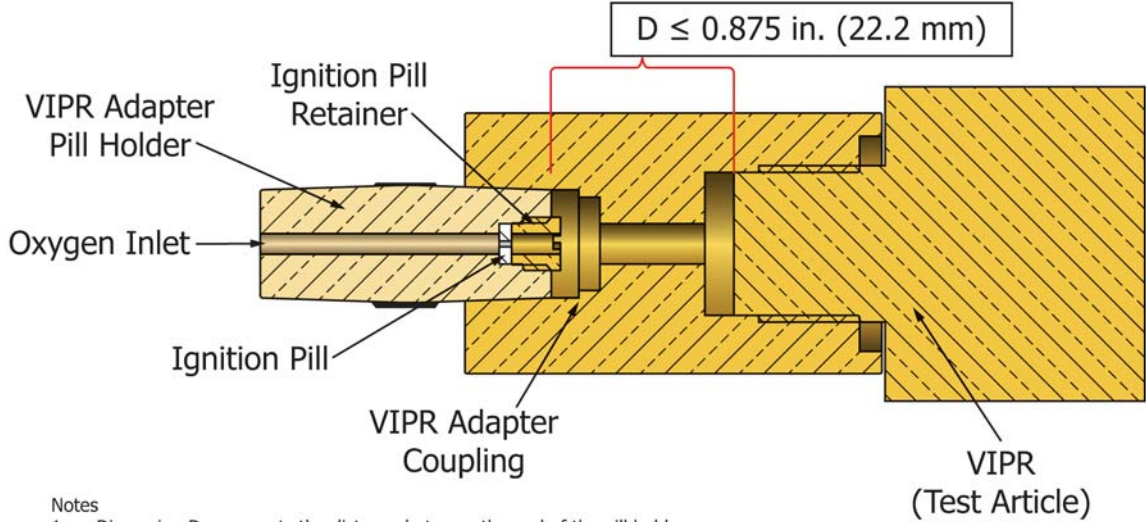

- Notes
1. Dimension D represents the distance between the end of the pill holder and the end of the VIPR cylinder connection as assembled in the VIPR

FIG. 20 Typical Ignition Pill Installed in VIPR Adapter Block

Some events are visible for only 1/25th of a second; therefore, video records should be scrutinized carefully.

8.2.7 *Testing*—Impact the ignition pill by fully pressurizing in 20 +0/-5 ms. Ensure that the fast-opening valve remains open for 10 s. After these 10 s, close the fast-opening valve and vent the test article to ambient pressure using an upstream vent valve. In the event of a catastrophic test article failure, the 10 s hold on the fast-opening valve does not apply and the fast-opening valve should be closed immediately.

8.2.8 *Observe External Evidence*—Review the test video and examine the post-test results to determine the following:

- 8.2.8.1 Were any parts, including the gauge, ejected from the test article?
- 8.2.8.2 Was any molten or burning material ejected from the test article?
- 8.2.8.3 Did a breach of the pressurized test article occur?
- 8.2.8.4 Were flames or sparks ejected through the normal vent ports for ≥ 1 s per test article? The time measurement method shall be the addition of the time represented by the frames of video exhibiting flame(s) and/or spark(s) ejecting through the normal vent paths.

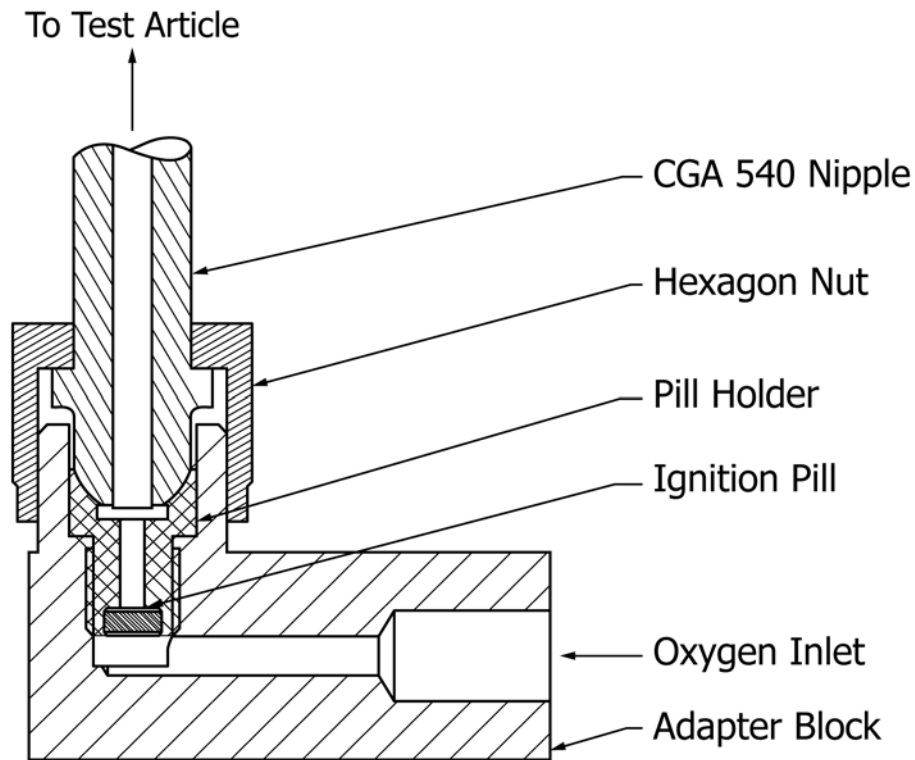

FIG. 14 Typical Ignition Pill Installed in CGA 540 Adapter Block

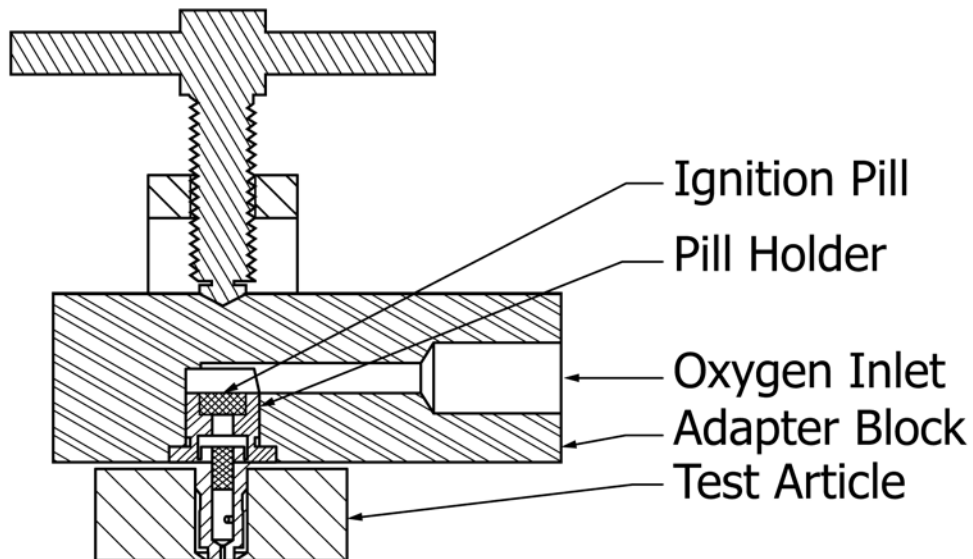

FIG. 15 Typical Ignition Pill Installed in CGA 870 Adapter Block

8.2.8.5 If a “yes” answer is given to any of these questions, the test article fails and is not considered fault-tolerant. When the test article has cooled sufficiently, remove it from the test system and document its condition per 9.3.4.

8.2.8.6 If “no” answers are given to all the questions in 8.2.8.1 – 8.2.8.4, remove the test article from the test system and proceed to 8.2.9.

8.2.9 *Disassembly and Inspection*—Disassemble and examine the post-test test article.

8.2.9.1 *Verify Pill Ignition*—If the ignition pill did not ignite, remove it, install a new pill, and repeat the test until ignition occurs. If the ignition pill ignited, verify the degree of its consumption per 8.2.9.2.

8.2.9.2 *Verify Appropriate Ignition Pill Consumption*—If any pill remnant is found, verify by visual inspection or by mass determination that greater than 90 % of the ignition pill was consumed.

(1) If less than 90 % of the pill was consumed, repeat the test with the same test article if it has not been damaged or with a new test article if necessary.

(2) If greater than or equal to 90 % of the pill was consumed, and “no” answers were given to all the questions in 8.2.8.1 – 8.2.8.4, the test article shall be considered fault tolerant.

9. Report

9.1 The following information regarding the test article evaluation shall be included.

9.2 Phase 1: Oxygen Pressure Shock Test

9.2.1 Test article manufacturer, model and serial numbers (if provided), test article type (e.g. CGA 870 pressure regulator, CGA 540 pressure regulator or VIPR), and a description of the seat, body, and trim materials,

9.2.2 Test media, including oxygen purity and specification,

9.2.3 Test conditions, including impact pressurization rates and test media temperature and pressure,

9.2.4 Pneumatic impact test results, including external evidence of ignition and combustion,

9.2.5 Post-test functional test results, and

9.2.6 Disassembly and inspection results, including a description of evidence of burning or charring and ignition/propagation, and photographs of the critical internal non-metallic materials such as the pressure regulator seat.

9.3 Phase 2: Promoted Ignition Test

9.3.1 Test article manufacturer, model and serial numbers, test article type (e.g., CGA 870 pressure regulator, CGA 540 pressure regulator or VIPR), and a description of the seat, body, and trim materials,

9.3.2 Test media, including oxygen purity and specification,

9.3.3 Test conditions, including impact pressurization rates and test media temperature and pressure,

9.3.4 Test results, including a written description of external evidence of pill ignition and sustained combustion and burnout of the test article if it occurred. Record whether or not a valid pill ignition occurred. If a valid pill ignition occurred, determine whether the test article is considered fault-tolerant by answering “no” to 9.3.4.1 – 9.3.4.4. “No” answers to all four indicate fault tolerance:

9.3.4.1 Indicate yes/no whether parts were ejected from the test article.

9.3.4.2 Indicate yes/no whether molten or burning materials were ejected from the test article.

9.3.4.3 Indicate yes/ no whether a breach of the pressurized test article component occurred.

9.3.4.4 Indicate yes/no whether flames or sparks were ejected through the normal vent ports for more than 1 s.

9.3.5 Post-test inspection, including verification that the ignition pill burned to >90 % consumption. Attach a photo of the post-test pill remains, and, for VIPRs, attach a photo of their SOV seat remains, and

9.3.6 Video record and/or still photographs (if taken).

10. Precision and Bias

10.1 No information is presented about either the precision or bias of Test Method G175 Phase 2 for measuring fault tolerance since the test result is non-quantitative. Two reference documents in Section 2.2 report interlaboratory testing performed according to Test Method G175 Phase 2 test for oxygen pressure regulators (Section 8.2.2). Appendix X7 discusses pilot testing and round robin testing performed for oxygen VIPRs.

11. Keywords

11.1 fault tolerance; forced ignition; ignition; ignition sensitivity; impact test; medical oxygen pressure regulator; oxygen pressure shock test; oxygen regulator; promoted ignition; valve integrated pressure regulator; VIPR

APPENDIXES

(Nonmandatory Information)

X1. OXYGEN COMPATIBILITY

X1.1 Oxygen pressure regulator and VIPR manufacturers and designers must address the issue of the hazards associated with the ignition and combustion of materials used in oxygen service. Experience indicates that ignition mechanisms are present under most service conditions. A hazards analysis process as described in Guides G63 and G94 and ASTM Manual 36 is recommended to assess materials compatibility

and flammability. The aim of these standards is to minimize the risk of ignition under reasonably foreseeable service conditions and to reduce the consequence of combustion. These standards recognize that good design and materials selection, along with proper operation, are essential in reducing the risk of fires in oxygen systems.

X2. TOXICITY

X2.1 In addition to the issue of flammability of materials used in medical gas systems, the risk of generating toxic combustion/decomposition products of such materials must be evaluated. It is essential that a risk analysis according to the requirements and methods of ISO 15001 be carried out on medical gas systems.

X2.2 Nonmetallic materials may ignite as a result of local heating by several common ignition sources, such as adiabatic compression and mechanical impact. Therefore, designers tend to choose materials with the highest possible autoignition temperature (AIT). However, several materials (including lu-

bricants) with a comparatively high AIT contain high proportions of fluorine or chlorine, such as polytetrafluoroethylene and polychlorotrifluoroethylene. All combustion and decomposition gases containing fluorine and chlorine are toxic; some are extremely toxic. Other widely used nonmetallic materials that contain nitrogen (polyamide, polyurethane) or sulfur (polyphenylene sulfide PPS) may also produce toxic combustion products, but these are generally less toxic than the gases that contain fluorine and chlorine. The gases released depend on the chemical composition and the conditions of combustion and decomposition, particularly temperature, pressure, and oxygen concentration.

X3. TEST PRESSURE RATIONALE

X3.1 During the initial development of this standard, it was determined that the minimum test pressure for Phase 2 of this standard would be 2200 psi (15 MPa) for oxygen pressure regulators because of the understanding that the CGA 870 pin-index style medical pressure regulators are not generally exposed to service pressures greater than 2200 psi in the United States of America. The original edition of this standard (2003) defined this minimum test pressure because of the relative flammability of typical materials of construction for these devices. Based on data from promoted combustion testing of 0.125 in. dia rods (ASTM G124), Al supports burning at ~25 psi, stainless steel at ~500 psi, and Zn at ~800 psi. On the other hand, 0.125 in. dia rods of brass, Cu, Monel K-500, Monel 400, and bronze will not support burning at pressures up to 10,000 psi (69 MPa). It is clear that Al, stainless steel, and Zn castings are flammable at either 2200 psi (15 MPa) or 3481 psi (24 MPa) and that brass, Cu, Monel, and bronze will not be flammable at either pressure. Therefore, a test run at either pressure will be effective to determine if the device is resistant

to burnout, which is the test objective. Furthermore, it was recognized that the pill will burn slightly faster at the higher test pressure than at the lower test pressure, but the total energy released will be the same. Based on these considerations, 2200 psi (15 MPa) was selected as the required minimum test pressure for this standard.

X3.2 However, a new understanding has been gained from the VIPR pilot and round robin testing programs. These programs showed that pressure influenced the test results for VIPRs. Therefore, it is recommended that the test pressure utilized for any component subjected to this standard be the maximum pressure that is expected under actual service conditions. Even with this new understanding, historical testing of CGA 870 pin-index style medical pressure regulators was considered credible because these regulators are not generally exposed to service pressures greater than 2200 psi and reports of in-service fires involving successfully tested regulators were unknown.

X4. VARIATION OF CGA 540 ADAPTER BLOCK AND PILL HOLDER

X4.1 Due to the difficulty of machining the CGA 540 adapter block shown in [Fig. 10](#), the following figures ([Fig.](#)

[X4.1](#) and [Fig. X4.2](#)) offer a variation of these parts to facilitate manufacturing.

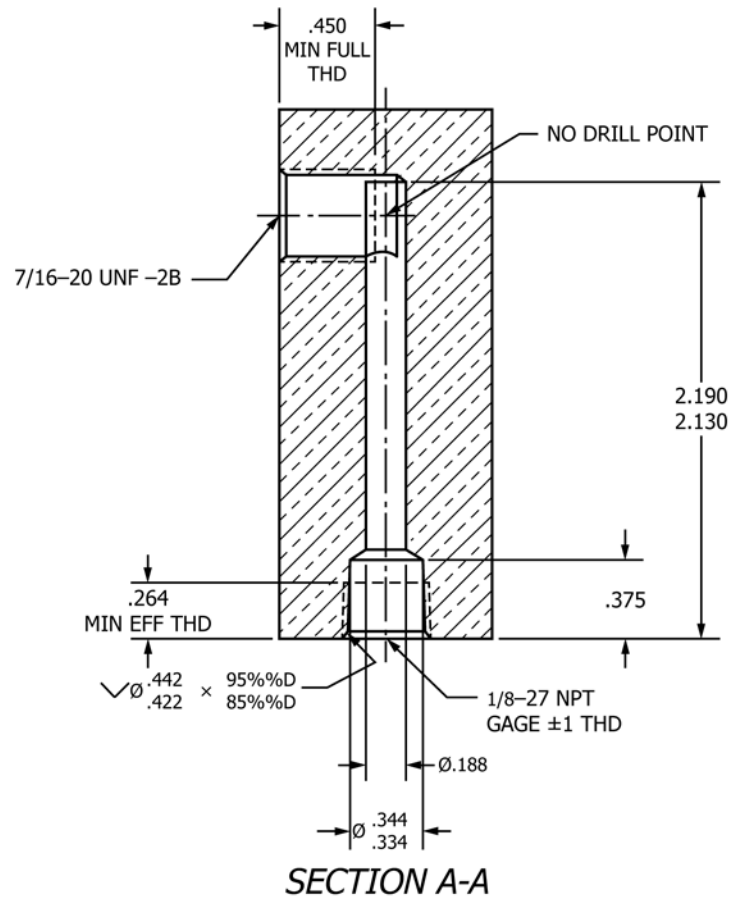
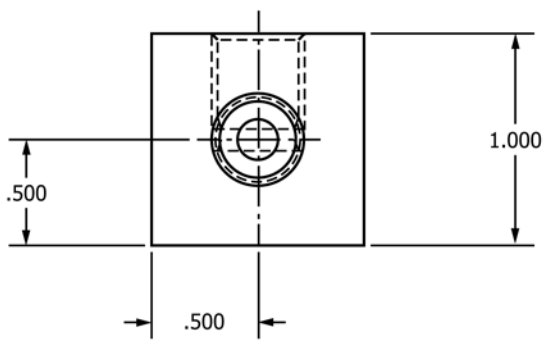
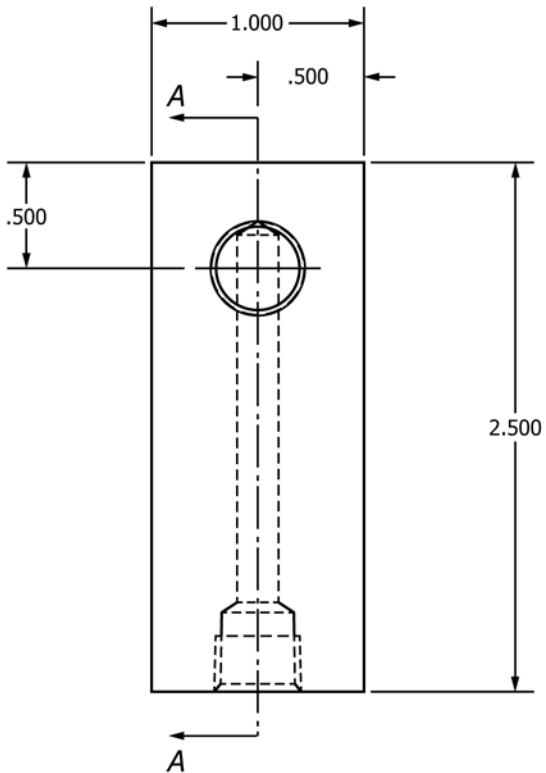

Notes:

1. Material: Brass (UNS C36000)
2. Unless otherwise specified, dimensions are in inches
3. 1 inch = 25.4 mm

FIG. X4.1 CGA 540 Adapter Block (alternative)

Notes:

1. Material: Brass (UNS C36000)
2. Unless otherwise specified, dimensions are in inches
3. 1 inch = 25.4 mm

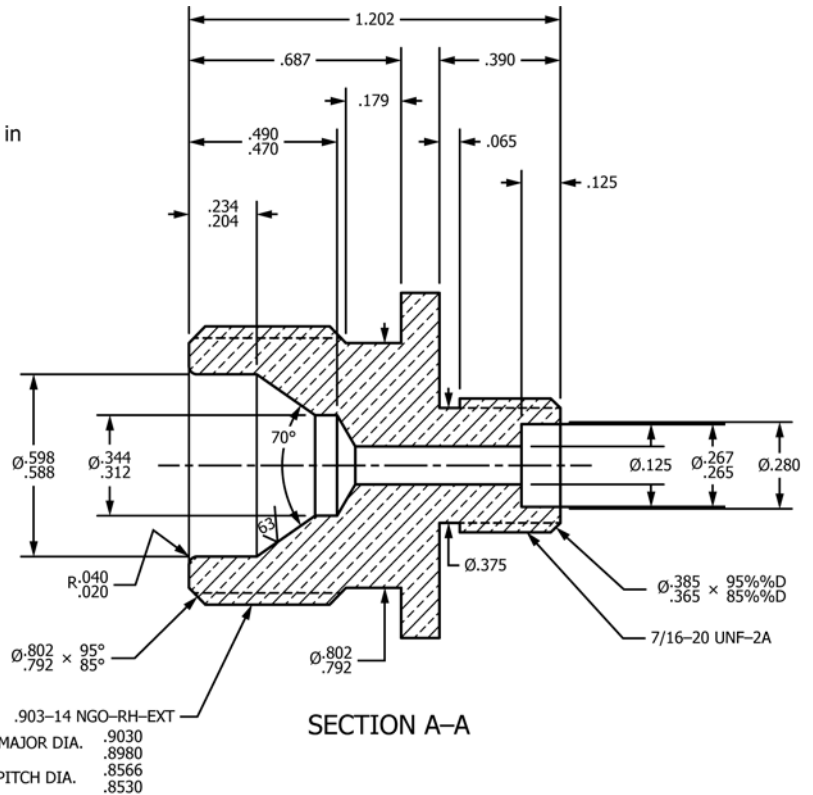
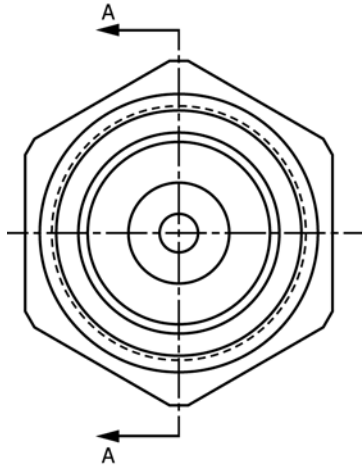

FIG. X4.2 CGA 540 Adapter Block (alternative)

X5. VIPR TEST MODE RATIONALE

X5.1 VIPR-style devices have two basic modes of operation: fill mode (when filling a cylinder) and patient-use mode (patient breathing oxygen through regulator portion). The ignition risks are different for each mode of operation. In the patient-use mode, the regulator portion is open and flowing, and the flow path includes the low-pressure regulator portion. Thus, promoted ignition fault tolerance testing in this configuration is consistent with the original intent of this standard for pressure regulators. In the fill mode configuration, the regulator portion is set to a closed position and thus the low-pressure

portion of the regulator is not exposed to flow. Consequently the ignition risks associated with the fill mode operation of a VIPR are consistent with those of a stand-alone cylinder valve during filling, and cylinder valves are not currently tested for promoted ignition fault tolerance.

X5.2 Based on these considerations, a promoted ignition fault tolerance test was selected only for the patient-use mode for VIPR-style devices.

X6. TESTING PRESSURE REGULATORS AND VIPRS WITH GAUGES

X6.1 If the design of the oxygen pressure regulator or VIPR includes a pressure gauge, the gauge shall be considered part of the test article and shall be included for testing.

X7. DEVELOPMENT OF 200 CAL IGNITION PILL FOR VIPRS

X7.1 The 200 cal ignition pill was developed and customized for VIPRs. The goal of this development work was to create an ignition pill that, upon combustion, would release sufficient energy to kindle the shut-off valve seat but not release an overwhelming amount of energy, as compared to the combustion energy release of a burning shut-off valve (SOV) seat. The ignition pill energy release also had to account for contamination in the VIPR (such as particles and residues), which would not be expected in new VIPRs that are typically provided as test articles. Therefore, the VIPR ignition pill development required several stages of research and development that are summarized below.

X7.2 Five VIPR models were inspected to evaluate their SOV seats and levels of contamination. Four to eight VIPRs of each model were included in the evaluation for a total of 31 VIPRs. Their SOV seats were removed and cleaned using a solvent extraction technique. After the cleaning, the seats were weighed and underwent material characterization to identify the SOV seat materials. Using the SOV seat mass and published heat of combustion data for the SOV seat materials identified, the total SOV seat combustion energy release was calculated. The solvent extraction used to clean the seats was used to identify and quantify the amount of contamination on the seats from six VIPRs that were in service for at least one year. Based on the heat of combustion and mass of the contaminants, the total contaminant combustion energy was calculated and found to be significantly less (up to two orders of magnitude) than the average SOV seat combustion energy, which was approximately 1600 cal. This indicated that the SOV seat (once ignited) would provide most of the initial combustion energy release. Since the average SOV seat combustion energy was greater than the 500 cal ignition pill used for oxygen pressure regulators, this ignition pill was nominated for pilot testing.

X7.2.1 The pilot testing used a VIPR model that had experienced fires in the field involving a shut-off valve seat ignition. The pilot testing of this VIPR model with a 500 cal ignition pill caused significantly more damage than the damage exhibited by the VIPRs in the field. Therefore, the 500 cal ignition pill was considered too severe for VIPRs. A 100 cal pill was designed and also tested using the same VIPR model. This ignition pill failed to provide sufficient energy to reliably ignite the SOV seat. Therefore, a 200 cal pill was developed and tested, and proved to reliably ignite the SOV seat of the same VIPR model.

X7.2.2 A round robin test program was performed and involved six laboratories and four VIPR models. The laboratories tested five VIPRs of each model per the test methodology outlined in the standard. Both fault-tolerant and non-fault-tolerant VIPRs were submitted for testing. Using the 200 cal pill, the SOV seats were consistently ignited and the test methodology was shown to be capable of identifying fault-tolerant and non-fault-tolerant VIPRs across the laboratories.

X7.3 Although the intent and desired result is to provide sufficient energy to ignite the shut-off valve seat, ignition of the shut-off valve seat is not required for a valid test. VIPR designs that do not include an SOV or VIPRs with designs that minimize the SOV seat size, or exposure to the oxygen flow, or both, may or may not experience SOV seat ignition when tested with a 200 cal pill. The exposure of these VIPR designs to the combustion energy of a 200 cal pill is a required and valid test to ensure VIPRs can safely tolerate an internal promoted ignition event, which could be initiated in service from the ignition of other polymers (e.g., seals) or contaminants.

ASTM International takes no position respecting the validity of any patent rights asserted in connection with any item mentioned in this standard. Users of this standard are expressly advised that determination of the validity of any such patent rights, and the risk of infringement of such rights, are entirely their own responsibility.

This standard is subject to revision at any time by the responsible technical committee and must be reviewed every five years and if not revised, either reapproved or withdrawn. Your comments are invited either for revision of this standard or for additional standards and should be addressed to ASTM International Headquarters. Your comments will receive careful consideration at a meeting of the responsible technical committee, which you may attend. If you feel that your comments have not received a fair hearing you should make your views known to the ASTM Committee on Standards, at the address shown below.

This standard is copyrighted by ASTM International, 100 Barr Harbor Drive, PO Box C700, West Conshohocken, PA 19428-2959, United States. Individual reprints (single or multiple copies) of this standard may be obtained by contacting ASTM at the above address or at 610-832-9585 (phone), 610-832-9555 (fax), or service@astm.org (e-mail); or through the ASTM website (www.astm.org). Permission rights to photocopy the standard may also be secured from the ASTM website (www.astm.org/COPYRIGHT/).