



Standard Test Method for Determination of Susceptibility of Metals to Embrittlement in Hydrogen Containing Environments at High Pressure, High Temperature, or Both¹

This standard is issued under the fixed designation G142; the number immediately following the designation indicates the year of original adoption or, in the case of revision, the year of last revision. A number in parentheses indicates the year of last reapproval. A superscript epsilon (ϵ) indicates an editorial change since the last revision or reapproval.

1. Scope

1.1 This test method covers a procedure for determination of tensile properties of metals in high pressure or high temperature, or both, gaseous hydrogen-containing environments. It includes accommodations for the testing of either smooth or notched specimens.

1.2 This test method applies to all materials and product forms including, but not restricted to, wrought and cast materials.

1.3 The values stated in SI units are to be regarded as standard. The values given in parentheses are for information only.

1.4 *This standard does not purport to address all of the safety concerns, if any, associated with its use. It is the responsibility of the user of this standard to establish appropriate safety and health practices and determine the applicability of regulatory limitations prior to use.*

2. Referenced Documents

2.1 *ASTM Standards:*²

[D1193 Specification for Reagent Water](#)

[E4 Practices for Force Verification of Testing Machines](#)

[E8 Test Methods for Tension Testing of Metallic Materials](#)

[E691 Practice for Conducting an Interlaboratory Study to Determine the Precision of a Test Method](#)

[G15 Terminology Relating to Corrosion and Corrosion Testing \(Withdrawn 2010\)](#)³

[G111 Guide for Corrosion Tests in High Temperature or High Pressure Environment, or Both](#)

¹ This test method is under the jurisdiction of ASTM Committee G01 on Corrosion of Metals and is the direct responsibility of Subcommittee G01.06 on Environmentally Assisted Cracking.

Current edition approved May 1, 2016. Published May 2016. Originally approved in 1996. Last previous edition approved in 2011 as G142 – 98 (2011). DOI: 10.1520/G0142-98R16.

² For referenced ASTM standards, visit the ASTM website, www.astm.org, or contact ASTM Customer Service at service@astm.org. For *Annual Book of ASTM Standards* volume information, refer to the standard's Document Summary page on the ASTM website.

³ The last approved version of this historical standard is referenced on www.astm.org.

[G129 Practice for Slow Strain Rate Testing to Evaluate the Susceptibility of Metallic Materials to Environmentally Assisted Cracking](#)

2.2 *Military Standard:*⁴

[MIL-P-27201B Propellant, Hydrogen](#)

3. Terminology

3.1 *Definitions:*

3.1.1 *control test, n*—a mechanical test conducted in an environment that does not produce embrittlement of a test material.

3.1.2 *hydrogen embrittlement, n*—hydrogen induced cracking or severe loss of ductility caused by the presence of hydrogen in the metal.

3.1.3 Other definitions and terminology related to testing can be found in Terminology [G15](#).

4. Summary of Test Method

4.1 Specimens of selected materials are exposed to a gaseous hydrogen containing environment at high pressure or high temperature, or both, while being pulled to failure in uniaxial tension. The susceptibility to hydrogen embrittlement is evaluated through the determination of standard mechanical properties in tension (that is, yield strength, ultimate tensile strength, notched tensile strength, reduction in area or elongation, or both). Comparison of these mechanical properties determined in a hydrogen-containing environment to those determined in a non-embrittling environment (control test) provides a general index of susceptibility to cracking versus the material's normal mechanical behavior.

5. Significance and Use

5.1 This test method provides a reliable prediction of the resistance or susceptibility, or both, to loss of material strength and ductility as a result of exposure to hydrogen-containing gaseous environments. This test method is applicable over a

⁴ Available from Standardization Documents Order Desk, DODSSP, Bldg. 4, Section D, 700 Robbins Ave., Philadelphia, PA 19111-5098

broad range of pressures, temperatures, and gaseous environments. The results from this test method can be used to evaluate the effects of material composition, processing, and heat treatment as well as the effects of changes in environment composition, temperature, and pressure. These results may or may not correlate with service experience for particular applications. Furthermore, this test method may not be suitable for the evaluation of high temperature hydrogen attack in steels unless suitable exposure time at the test conditions has taken place prior to the initiation of tensile testing to allow for the development of internal blistering, decarburization or cracking, or both.

6. Apparatus

6.1 Since this test method is intended to be conducted at high pressures and may also involve high temperatures, the apparatus must be constructed to safely contain the test environment while being resistant to the embrittling effects of hydrogen. Secondly, the test apparatus must be capable of allowing introduction of the test gas, removal of air from the test cell, and accurate performance of the tension test on the test specimen. In cases where the tests are conducted at elevated temperatures, the apparatus must provide for heating of the specimen and the test environment in direct contact with the specimen.

6.2 Fig. 1 shows a schematic representation of a typical test cell designed to conduct HP/HT gaseous hydrogen embrittlement experiments.⁵ The typical components include:

6.2.1 *Metal Test Cell*—The test cell should be constructed from materials that have proven to have high resistance to hydrogen embrittlement under the conditions. A list of potential materials of construction is shown in Fig. 2.⁶ Materials with high values of tensile ratios (environment versus a control environment) should be used. Materials with low values of this parameter should be avoided.

6.2.2 *Closure and Seal*—To facilitate operation of the test cell and tension testing, the closure should provide for rapid opening and closing of the test cell and reliable sealing capabilities for hydrogen. This can include either metallic or nonmetallic materials with high resistance to hydrogen embrittlement and degradation.

6.2.3 *Gas Port(s)*—The gas port should be designed to promote flow and circulation of the gaseous test environments, inert gas purging and evacuation as required to produce the intended test environment. Usually two ports are used so that flow-through capabilities are attained to facilitate these functions.

6.2.4 *Electrical Feed-Throughs*—If very high temperature conditions are required it may be advantageous to utilize an internal heater to heat the test specimen and the gaseous environment in the immediate vicinity of the specimen. Therefore, a feed-through would be needed to reach an internal resistance or induction heater. These feed-throughs must also

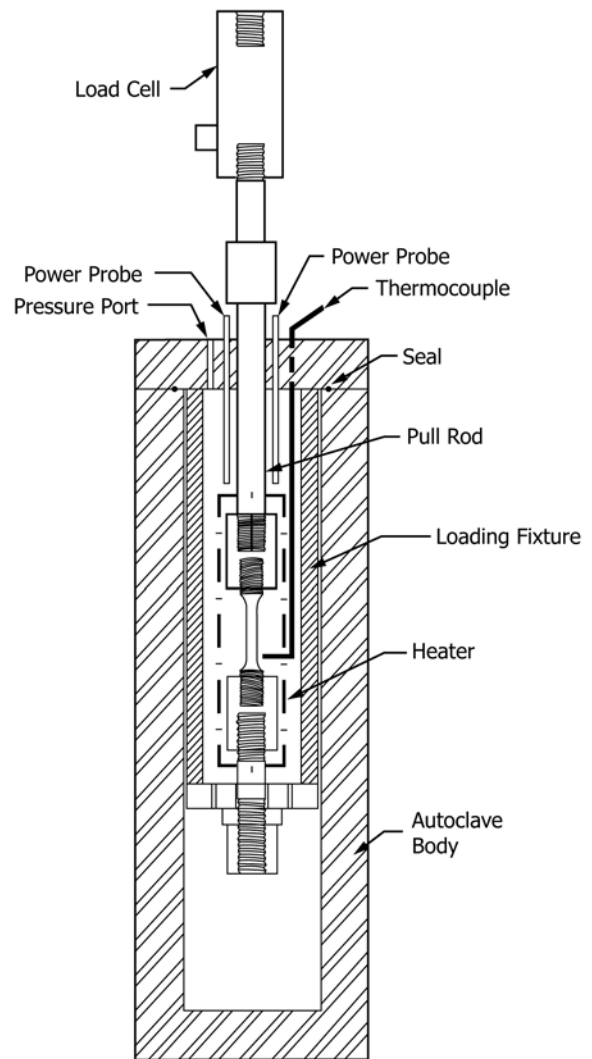

(CDN10127)

FIG. 1 Hydrogen Tensions Test Autoclave for Various Alloys in Hydrogen versus Air

provide electrical isolation from the test cell and internal fixtures, and maintain a seal to prevent leakage of the test environment. If external heaters are used, no electric feed-throughs would be required for testing.

6.2.5 *Tensile Feed-Through(s)*—To apply tensile loading to the test specimen it is necessary to have feed-through(s) which provide linear motion and transmission of loads from an external source. Care must be taken to design such feed-throughs to have low friction to minimize errors due to friction losses when using externally applied loads. These are usually designed to incorporate thermoplastic or elastomeric materials, or both. If elevated temperature tests are being conducted, then extreme care must be used in the selection of these materials to also resist deterioration and loss of mechanical properties at the test temperature.

6.2.6 *Pull Rod*—The pull rod works in combination with the tensile feed-through to provide for loading of the test specimen. It is usually attached to a tensile testing machine on one

⁵ Kane, R. D., "High Temperature and High Pressure," *Corrosion Tests and Standards*, Baboian, Robert, editor, ASTM, West Conshohocken, PA.

⁶ *Metals Handbook, Vol 9, Corrosion*, 9th Edition, ASM International, Metals Park, OH, 1987, p. 1104.

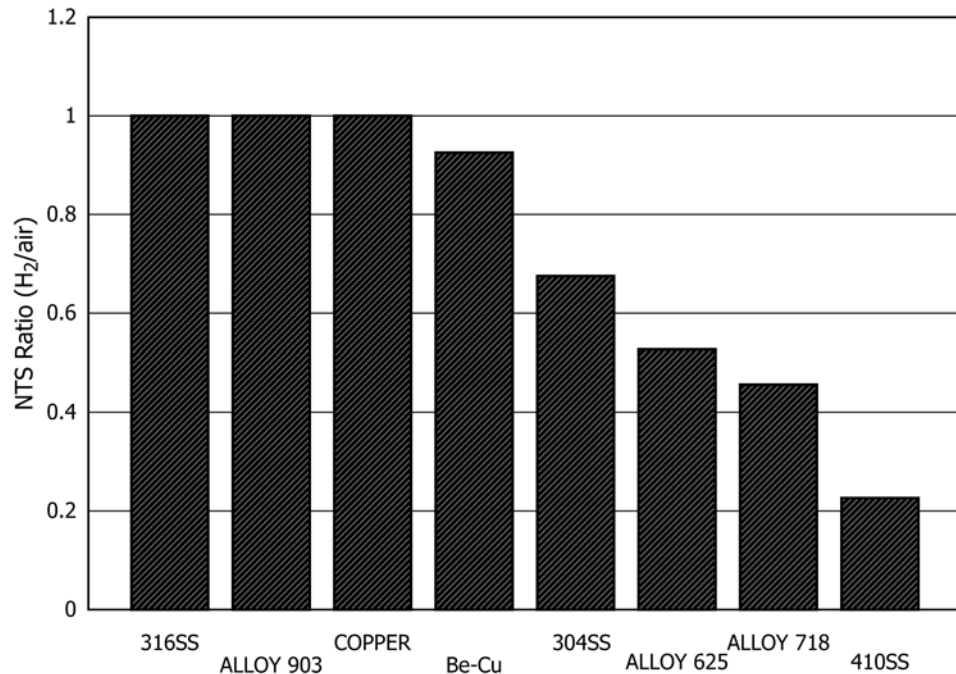

FIG. 2 Notched Tensile Strength (NTS) Ratio for Various Alloys in 35 to 69 MPa Gaseous Hydrogen versus Air Tested at Room Temperature

end and the tension specimen on the other. It should be designed to have adequate cross-sectional area to minimize compliance in the loading system under the anticipated loads to be used. Also, to minimize frictional forces in the seal and promote sealing, it should be made with a highly polished surfaces [$<0.25\ \mu\text{m}$ (10 $\mu\text{in.}$) RMS]. It is possible to obtain pull rod systems that are pressure balanced so specimen loading from the internal pressure in the test cell can be minimized.

6.2.7 *Load Cell*—Load cells for conducting high pressure tensile tests may be two configurations:

6.2.7.1 External load cells which are attached to the pull rod outside of the test cell, and

6.2.7.2 Internal load cells which are either attached to the pull rod or grip assembly inside of the autoclave or are integrated into the pull rod. When using external load cells it is important to correct load cell readings for frictional forces in the pressure seal. Additionally, if non-pressure balanced pull rods are used, compensation for pressure loading of the specimen must be also performed.

6.2.8 *Electric Resistance or Induction Heater(s)*—Either internal or external heaters can be used to obtain elevated temperature. For lower temperatures, and when using test environments containing reactive constituents in addition to hydrogen, external heating of the test cell is typically more convenient. At high temperatures, when using non-reactive or hydrogen gas environments, an internal heater can be used to heat only the test specimen and the gaseous environment in the vicinity of the test specimen to limit power requirements and problems with high temperature sealing and pressure containment.

6.2.9 *Grips*—Grips shall provide for efficient and accurate transfer of load from the pull rods to the test specimen. Grips

should be designed to minimize compliance in the loading system under the anticipated loads to pull the test specimen.

6.2.10 *Loading Fixture*—A fixture is used to react the load used to pull the specimen. An internal fixture is shown schematically in Fig. 1.

6.2.11 *Testing Machines*—Tension testing machines used for conducting tests according to this test method shall conform to the requirements of Practices E4. The loads used in tests shall be within the calibrated load ranges of the testing machines in accordance with Practices E4.

7. Reagents

7.1 *Purity of Reagents*—Reagent grade chemicals and ultra low oxygen gases ($<1\ \text{ppm}$) shall be used in all tests unless the test environment is derived from a field or plant environment. If the test is to be conducted for aerospace propulsion applications, the environment shall consist of hydrogen gas per MIL-P-27201B.

7.2 If water is to be added to any test environment, distilled or deionized water conforming to Specification D1193 Type IV shall be used.

8. Test Environment

8.1 Test environments can consist of either field or plant samples or be prepared in the laboratory from chemicals and gases as indicated in Section 7.

8.2 When testing in hydrogen containing environments, susceptibility to hydrogen embrittlement typically increases with decreasing oxygen content of the test environment.

Therefore, strict procedures for deaeration shall be followed and periodically qualified for oxygen content as discussed in Sections 9 and 11.

8.3 For purposes of standardization, suggested standardized pressures for hydrogen gas testing shall be 7 MPa, 35 MPa, and 69 MPa. However, for materials evaluation for specific applications, the test pressure should be equal to or greater than that which represents the service conditions.

9. Sampling

9.1 The procedure for sampling mill products is typically covered in product or other specifications and is outside the scope of this document.

9.2 Sampling of the test environment is recommended to confirm that the test environment is in conformance with this test method and attains the intended test conditions. Such sampling shall be conducted immediately prior to and after testing. The frequency of environmental sampling shall be as required to cover applicable product, purchase or in-house testing specifications, or both. As a minimum requirement to be in compliance with this test method, however, sampling of the test environment shall be conducted at the start of testing and again when any element of the test procedure or test system has been changed or modified.

10. Test Specimens

10.1 Tension specimens shall be used for evaluation of hydrogen embrittlement. These specimens shall conform to the dimensions and guidelines provided in Test Methods E8. However, in some cases, the material size, configuration, and form or the confines of various test cells may limit the actual dimensions of the test specimen. In such cases, the specimen geometry and dimensions shall be fully described. Take care to only compare the results obtained from similar specimens.

10.2 For purposes of standardizing the evaluation of materials according to this test method, two standard test specimens shall be used: standard smooth tension specimen, and standard notched tensile specimen. The dimensions of these specimens are given in Fig. 3a and Fig. 3b.

10.3 Specimens shall be machined to have a minimal amount of cold work on the gage or notch surfaces. Total metal removed in the last two passes shall be limited to a total of 0.05 mm and have a surface finish of 0.25 μm (10 $\mu\text{in.}$) or better. The method of final machining of the gage section should be by grinding (not turning) to avoid localized grooves and cold worked areas.

11. Standardization

11.1 To provide an indication when some inadvertent deviation from the correct test conditions occurs, it is necessary to test a control specimen of a material of known susceptibility to hydrogen embrittlement using the procedures given herein. This control material should exhibit an easily reproducible degree of embrittlement.

11.2 The control materials for tests conducted in a hydrogen containing environment shall be as given below:

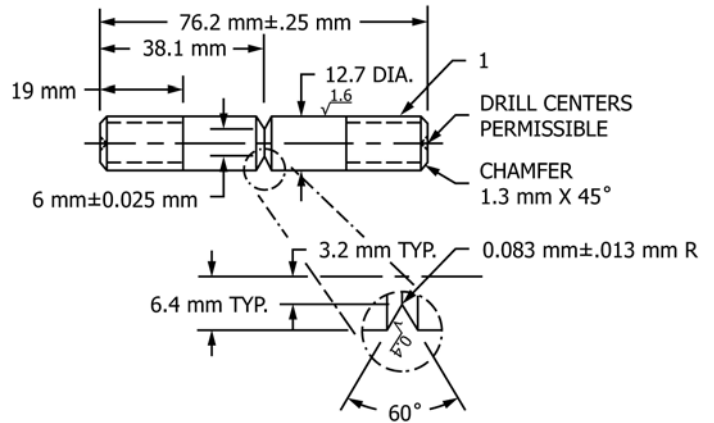
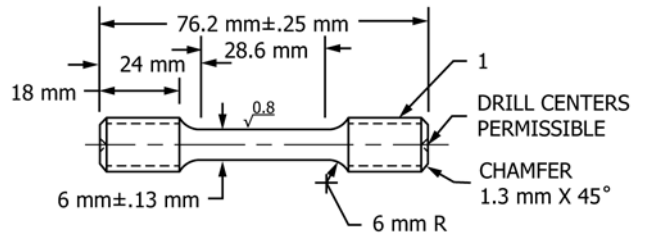

1 – M12 x 1,5
1/2"–20 UNF–2A

FIG. 3 Standard Tension Specimens (a) Smooth and (b) Notched

11.2.1 *Low Resistance*—Low Alloy Steel: UNS G43400 (austenitize at 900°C for 1 h plus water quench and temper at 454°C for 2 h).

11.2.2 *Intermediate Resistance*—Nickel Base Alloy: UNS N07718 (solution annealed at 954°C for 1 h plus air cool; age at 718°C for 8 h plus furnace cool to 620°C hold for 8 h plus air cool).

11.2.3 *High Resistance*—Stainless Steels: A 286—AMS 5737 (solution annealed at 893°C for 1 h plus water quench and aged at 721°C for 16 h plus air cool).

12. Test Procedure

12.1 Follow the basic guidelines for high pressure/high temperature corrosion testing in Guide G111 where applicable.

12.2 Measure the initial specimen dimensions. For smooth tensile specimens, the dimensions measured are gage length and diameter. For notched specimens, the dimensions are gage and notch diameter.

12.3 Degrease and clean the specimen. Once cleaned the specimen shall not be handled with bare hands.

12.4 Mount the specimen in the test cell using suitable grips which are attached to the pull rods. Take care to prevent misalignment and non-axial loading. See Test Methods E8 for more information. Upon initial set-up of the test cell, an alignment verification using an instrumented dummy specimen is recommended.

12.5 After sealing the test cell, remove air from the test vessel and associated system, using alternate vacuum/inert gas (that is, argon or helium) purges which reduce the oxygen level in the test cell to the desired level. The procedure for this may vary slightly depending on the specific test system used, but it should typically involve evacuation of the test cell followed by back-filling with inert gas. For testing in hydrogen containing environments, it is recommended that at least three vacuum/inert gas cycles be used. The procedure used in deaeration shall be verified by gas analysis and re-verified following any change in the pressure containing portion of the test system or deaeration procedure.

12.6 To ensure the pressure integrity of the system prior to testing, the test cell shall be pressure tested with inert gas to at least the intended test pressure and held for at least 10 min while monitoring for leaks or pressure loss, or both.

12.7 Upon completion of the pressure test, release and apply another vacuum to the inert gas. The test gas is then back-filled into the test cell and pressurized to the intended pressure. This may be accomplished using bottle pressure or with a gas booster pump. Take care to ensure that air is not introduced into the test cell during the pumping process. If the test is to be conducted at elevated temperature, the initial gas pressure should be that which when heated to the desired temperature will produce the intended test pressure.

12.8 If any portion of the test system is disconnected or replaced during the process of evacuation or pressurization with the inert or test gases, the procedure must be reinitiated.

12.9 If the test is to be conducted at elevated temperature, the heat should be applied in a slow steady manner so that the pressure increase during heating can be monitored and the temperature does not overshoot the intended test temperature. If either the temperature or pressure overshoots the desired level by more than 5°C or 300 kPa, then the test must be conducted at those conditions or discontinued. During heating, the load on the specimen shall be monitored with the load cell. Take care to prevent either excessive compressive or tensile loading of the specimen, taking into account such factors as pressure loads and thermal expansion of the specimen, grips, and pull rods.

12.10 Once the temperature and pressure have stabilized for a period of 10 min, commence the tension testing of the specimen. In some situations, it may be desirable to simulate service conditions by allowing for a longer hold period at temperature and pressure to allow for diffusion of hydrogen into the material or formation of internal damage, or both. If this is the case, note the length of this hold period.

12.11 Use a constant extension rate to pull the test specimen. For smooth tension specimens, use an extension rate of 0.002 mm/s \pm 10 % based on extension in the gage section of the specimen. For notched specimens, use an extension rate of 0.02 mm/s \pm 10 % based on the testing machine cross-head extension. For full characterization of the hydrogen embrittlement behavior of the material, it may be necessary to conduct tests at extension rates either higher or lower than the values stated herein.

12.12 Record load and cross-head displacement from application of load to failure.

12.13 From the load displacement curve, determine the following information:

12.13.1 *For Smooth Specimens*—Plastic elongation (that is, elongation from the elastic limit to failure), ultimate tensile strength and reduction in area, and the ratios of these values for environment and control tests, in accordance with Practice G129.

12.13.2 *For Notched Specimens*—Ultimate tensile strength and reduction in area, and the ratios of these values for environment and control tests, in accordance with Practice G129.

12.14 Evaluation of the test data can be conducted directly using the values of the parameters given in 12.13. However, to assess susceptibility to cracking in hydrogen containing environments it is common to use the ratio of the parameters given in 12.12 with corresponding data developed for the same material in the control test conducted in an inert gas environment at the same temperature and pressure as the hydrogen environment test. Values of these ratios near unity typically indicate high resistance to hydrogen embrittlement and lower values indicate susceptibility to embrittlement.

13. Reporting

13.1 *Report the following information:*

13.1.1 Material characterization including chemical composition, mechanical properties from conventional tension tests, product form, heat treatment, section size, and sampling procedures.

13.1.2 Specimen characterization including orientation, type, size, number of specimens tested, and surface preparation.

13.1.3 Initial strain rate and pre-load.

13.1.4 Documentation of the test environment as applicable; including aeration or deaeration procedure, temperature, pressure, chemical constituents, and partial pressure of gaseous constituents.

13.1.5 Tension test results including load displacement curves and tension test properties and their ratios for tests conducted in environment versus control environment as described in 12.13.

13.1.6 Examination of the specimen gage section and fracture surface using appropriate analysis techniques to determine fracture mode and evaluation of evidence of secondary cracking. Such techniques may include microscopy, scanning electron microscopy, and metallographic sectioning. Photomicrographs of the fracture and surrounding areas should be included.

14. Precision and Bias

14.1 *Precision*—An interlaboratory hydrogen tension test program⁴ was used to develop values for the standard deviation of cell averages ($S_{\bar{x}}$), the repeatability standard deviation (S_r), and the reproducibility standard deviation (S_R) on hydrogen tensile properties. The repeatability standard deviation is a measure of within laboratory variation, while the reproducibility standard deviation is a measure of variation between

laboratories. These were converted into coefficients of variation form by dividing by the average value of the property. This information is summarized in **Table 1**. The results for all data sets along with the respective statistical treatments and 95 % confidence intervals are given in **Appendix X1** (see **Tables X1.1-X1.5**). The results presented may not be typical of every exposure situation.

14.1.1 The interlaboratory study was run on four material/pressure combinations with all tests conducted at laboratory room temperature. These combinations involved two lots of alloy 718 at 7 MPa and 35 MPa. They were in the midrange embrittlement region, in that none of the material/pressure

combinations were expected to show embrittlement or to be severely embrittled. The laboratories ran three sample data sets, with up to 14 sets of data per material/pressure combination. The tensile and yield strength values were comparable to the precision statement of Test Methods **E8**, while the elongation and reduction of area values were much higher. These values should be used to evaluate whether this method can be employed for the proposed application. Users of this test method should also understand that, for tensile properties, hydrogen environment embrittlement will influence ductility and notch properties much more than yield and tensile strength.

14.2 *Bias*—No information can be presented on the bias of this test method for measuring mechanical properties such as ultimate tensile strength, notched tensile strength, in area or elongation because these properties are defined only in terms of this test method.

15. Keywords

15.1 high pressure; high temperature; hydrogen embrittlement; tension testing

TABLE 1 Coefficient of Variation of Hydrogen Tensile Properties

	Tensile Strength	Yield Strength Offset = 0.2 %	Elongation Gage Length = 4 Diameters	Reduction of Area	Notch Tensile Strength
S_x	2.1 %	2.0 %	22.4 %	29.2 %	6.6 %
S_r	1.3 %	2.1 %	14.5 %	20.0 %	5.0 %
S_R	2.4 %	2.8 %	25.7 %	34.4 %	7.8 %

APPENDIX

(Nonmandatory Information)

X1. FACTORS AFFECTING HYDROGEN TENSION TEST RESULTS

X1.1 Hydrogen tension test strength and ductility measurements generated according to this test procedure are influenced by test system, sample preparation, time at test conditions prior to testing, and material factors. Consistency of results for repeated tests of the same material is dependent on the homogeneity of the material and the repeatability of test procedures and specimen preparation.

X1.2 All factors discussed in **Appendix X1** of Test Methods **E8** applies to tension testing in hydrogen environments.

X1.3 Hydrogen/material interaction is influenced by both the surface condition of the test sample and the purity of the test media. Contamination of either will influence the repeatability and reproducibility of the test results.

X1.4 Hydrogen tensile properties are dependent on test strain rate. Testing must be conducted in either strain or stroke control. Testing in load control can subject the specimen to

very high post yield strain rates, which could possibly mask a materials hydrogen environment embrittlement problem.

X1.5 Interlaboratory Hydrogen Tension Test Program

X1.5.1 An interlaboratory test program was conducted on a material processed with two different heat treatments. The heat treatments produced two materials with highly different hydrogen environment embrittlement resistance. Room temperature tension tests were conducted on both materials at two test pressures. Triplicate specimens were tested at four material/pressure combinations. **Tables X1.1-X1.5** present the precision statistics (as defined in Practice **E691**) for tensile strength, 0.2 % yield strength, percent elongation, percent reduction of area, and notch tensile strength, respectively.

X1.5.2 The overall averages (in the sixth column) permit a relative comparison of the coefficient of variations for repeatability (within lab variation) and reproducibility (between lab variation).

TABLE X1.1 Precision Statistics—Tensile Strength, ksi

Material Test Environment	IN 718 AMS 5662		IN 718 AMS 5664		Overall Average
	7 MPa GH2 ^A	35 MPa GH2	7 MPa GH2	35 MPa GH2	
Number of laboratories (3 samples per lab)	14	10	14	8	
Average of lab averages \bar{X}	209.7	201.8	199.1	194.7	
Standard deviation of cell averages $s_{\bar{x}}$	4.5	4.3	4.2	3.7	
Coefficients of variation on lab averages	2.2 %	2.1 %	2.1 %	1.9 %	2.1 %
Repeatability standard deviation s_r	2.2	3.1	3.8	1.1	
Repeatability coefficients of variation	1.1 %	1.5 %	1.9 %	0.6 %	1.3 %
95 % repeatability limits, r	6.2	8.7	10.7	3.0	
Reproducibility standard deviation s_R	4.9	5.0	5.3	3.8	
Reproducibility coefficients of variation	2.3 %	2.5 %	2.6 %	2.0 %	2.4 %
95 % reproducibility limits, R	13/6	13/9	14.8	10.8	

^A GH2 = Gaseous hydrogen.

TABLE X1.2 Precision Statistics—Yield Strength, ksi

Material Test Environment	IN 718 AMS 5662		IN 718 AMS 5664		Overall Average
	7 MPa GH2 ^A	35 MPa GH2	7 MPa GH2	35 MPa GH2	
Number of laboratories (3 samples per lab)	14	10	14	8	
Average of lab averages \bar{X}	172.6	171.4	160.5	158.6	
Standard deviation of cell averages $s_{\bar{x}}$	4.0	3.0	3.1	3.0	
Coefficients of variation on lab averages	2.3 %	1.7 %	1.9 %	1.9 %	2.0 %
Repeatability standard deviation s_r	3.5	2.0	6.5	1.9	
Repeatability coefficients of variation	2.1 %	1.2 %	4.1 %	1.2 %	2.1 %
95 % repeatability limits, r	9.8	5.6	18.2	5.3	
Reproducibility standard deviation s_R	5.0	3.4	6.5	3.4	
Reproducibility coefficients of variation	2.9 %	2.0 %	4.1 %	2.1 %	2.8 %
95 % reproducibility limits, R	14.0	9.5	18.2	9.5	

^A GH2 = Gaseous hydrogen.

TABLE X1.3 Precision Statistics—% Elongation in 4D

Material Test Environment	IN 718 AMS 5662		IN 718 AMS 5664		Overall Average
	7 MPa GH2 ^A	35 MPa GH2	7 MPa GH2	35 MPa GH2	
Number of laboratories (3 samples per lab)	14	10	13	9	
Average of lab averages \bar{X}	13.3 %	7.5 %	23.0 %	12.2 %	
Standard deviation of cell averages $s_{\bar{x}}$	3.1 %	2.5 %	2.6 %	2.8 %	
Coefficients of variation on lab averages	22.9 %	32.6 %	11.1 %	23.2 %	22.4 %
Repeatability standard deviation s_r	2.9 %	1.4 %	2.4 %	0.8 %	
95 % repeatability limits, r	8.1 %	3.9 %	6.7 %	2.2 %	
Repeatability coefficients of variation	21.8 %	19.2 %	10.4 %	6.4 %	14.5 %
Reproducibility standard deviation s_R	3.9 %	2.7 %	3.2 %	2.9 %	
Reproducibility coefficients of variation	29.0 %	36.2 %	14.0 %	23.7 %	25.7 %
95 % reproducibility limits, R	10.1 %	7.6 %	9.0 %	8.1 %	

^A GH2 = Gaseous hydrogen.

TABLE X1.4 Precision Statistics—% Reduction-in-Area

Material Test Environment	IN 718 AMS 5662		IN 718 AMS 5664		Overall Average
	7 MPa GH2 ^A	35 MPa GH2	7 MPa GH2	35 MPa GH2	
Number of laboratories (3 samples per lab)	14	10	14	9	
Average of lab averages \bar{X}	17.1 %	9.8 %	30.6 %	14.7 %	
Standard deviation of cell averages $s_{\bar{x}}$	4.7 %	2.5 %	8.6 %	5.1 %	
Coefficients of variation on lab averages	27.8 %	26.0 %	28.1 %	35.0 %	29.2 %
Repeatability standard deviation s_r	5.6 %	2.5 %	2.9 %	1.8 %	
Repeatability coefficients of variation	32.7 %	25.8 %	9.4 %	12.0 %	20.0 %
95 % repeatability limits, r	15.7 %	7.0 %	8.1 %	5.0 %	
Reproducibility standard deviation s_R	6.6 %	3.3 %	8.9 %	5.3 %	
Reproducibility coefficients of variation	38.6 %	33.4 %	29.1 %	36.4 %	34.4 %
95 % reproducibility limits, R	18.5 %	9.2 %	24.9 %	14.8 %	

^A GH2 = Gaseous hydrogen.

TABLE X1.5 Precision Statistics—Notch Tensile Strength, ksi

Material Test Environment	IN 718 AMS 5662		IN 718 AMS 5664		Overall Average
	7 MPa GH2 ^A	35 MPa GH2	7 MPa GH2	35 MPa GH2	
Number of laboratories (3 samples per lab)	13	9	11	9	
Average of lab averages \bar{X}	277.5	229.7	320.5	293.3	
Standard deviation of cell averages $s_{\bar{x}}$	26.5	20.8	10.4	13.7	
Coefficients of variation on lab averages	9.5 %	9.1 %	3.2 %	4.7 %	6.6 %
Repeatability standard deviation s_r	15.1	20.0	5.1	12.1	
Repeatability coefficients of variation	5.4 %	8.7 %	1.6 %	4.1 %	5.0 %
95 % repeatability limits, r	42.3	56.0	14.3	33.9	
Reproducibility standard deviation s_R	29.2	26.5	11.2	16.9	
Reproducibility coefficients of variation	10.5 %	11.5 %	3.5 %	5.8 %	7.8 %
95 % reproducibility limits, R	81.8	74.2	31.4	47.3	

^A GH2 = Gaseous hydrogen.

ASTM International takes no position respecting the validity of any patent rights asserted in connection with any item mentioned in this standard. Users of this standard are expressly advised that determination of the validity of any such patent rights, and the risk of infringement of such rights, are entirely their own responsibility.

This standard is subject to revision at any time by the responsible technical committee and must be reviewed every five years and if not revised, either reapproved or withdrawn. Your comments are invited either for revision of this standard or for additional standards and should be addressed to ASTM International Headquarters. Your comments will receive careful consideration at a meeting of the responsible technical committee, which you may attend. If you feel that your comments have not received a fair hearing you should make your views known to the ASTM Committee on Standards, at the address shown below.

This standard is copyrighted by ASTM International, 100 Barr Harbor Drive, PO Box C700, West Conshohocken, PA 19428-2959, United States. Individual reprints (single or multiple copies) of this standard may be obtained by contacting ASTM at the above address or at 610-832-9585 (phone), 610-832-9555 (fax), or service@astm.org (e-mail); or through the ASTM website (www.astm.org). Permission rights to photocopy the standard may also be secured from the Copyright Clearance Center, 222 Rosewood Drive, Danvers, MA 01923, Tel: (978) 646-2600; http://www.copyright.com/