



Standard Practice for Security Engineering Symbols¹

This standard is issued under the fixed designation F967; the number immediately following the designation indicates the year of original adoption or, in the case of revision, the year of last revision. A number in parentheses indicates the year of last reapproval. A superscript epsilon (ε) indicates an editorial change since the last revision or reapproval.

1. Scope

1.1 This practice utilizes symbols to depict security systems and equipment requirements for architectural or engineering drawings that are produced either manually or by computer aided design (CAD). The symbols depicted include some symbols that have already been somewhat universally accepted or that have already been adopted by a standards-writing body, such as by the National Fire Protection Association.

1.2 It is not proposed that all of the symbols need to be utilized since the level of detail required for drawings is likely to vary. Generic symbols of a class of security device may be sufficient in some instances. Moreover, the need to provide a measure of security in the actual drawing may also suggest a need to utilize a generic symbol rather than to depict the exact device being installed.

1.3 In the event that a greater level of detail is required, it is possible to combine many of the symbols to create new symbols that achieve the desired level. While some combinations of symbols are shown, it would be impractical to attempt to depict every conceivable combination of symbols. It is also the intent of this practice that the symbols be capable of being continuously expanded and modified as the industry state of the art changes or as emphasis varies. For example, little attention is given to document security in the security symbols since such requirements are not generally fully met during construction periods but are rather developed and provided for subsequently. Since much of this equipment is not installed but is “placed,” such as furniture, there is only one symbol proposed (for example, for document shredders).







1.4 *This standard does not purport to address all of the safety concerns, if any, associated with its use. It is the responsibility of the user of this standard to establish appropriate*

safety and health practices and determine the applicability of regulatory limitations prior to use.



2. Keywords

2.1 computer aided design; security engineering; symbols

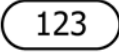
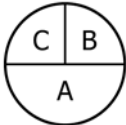
1. ANNOTATION











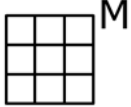





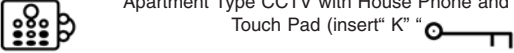











-  Existing Equipment
-  Point and Zone Indicator
-  Connection Between Devices (for example, button and lock)
-  Detail and Reference Drawing
-  Door Number (if more than one door in room, use sub-letter)
-  Room or Space Number
-  Device Number (reference device schedule)
-  Device Reference
A = Drawing Sheet
B = Detail
C = Device/Zone Number

2. ACCESS CONTROL

-  Generic Card Reader (reference door schedule or specifications for type): P = pedestal mount
-  Card Reader with Touch Pad

¹ This practice is under the jurisdiction of ASTM Committee F12 on Security Systems and Equipment and is the direct responsibility of Subcommittee F12.10 on Systems Products and Services.

Current edition approved March 1, 2011. Published June 2011. Originally approved in 1986. Last previous edition approved in 2003 as F967 – 03. DOI: 10.1520/F0967-03R11.

	Token-Type Access Control		Keypad Device
	CCTV and Card Reader		Card Reader with Keypad
	CCTV and Intercom		Card Reader with Time and Attendance
	Split Lens CCTV with ID Card Receptacle		
	Apartment Type CCTV with House Phone and Touch Pad (insert "K" " ", as appropriate for key switch)		
	Biometric Access Control Device (reference door schedule or specifications for type)		
	Touch Pad Lock or Device, Mechanical or Electronic (reference door schedule for type)		
	Turnstile (reference door schedule for type and function)		
	Post and Rail (rope)		
	Generic Screening Device X: M = Metal Detector E = Explosive Detector X = X-ray T = Tag Detector (EAS)		
	Sally Port		
	Indicating Interlocking Doors		
	Indicating Space is a "Man-Trap"		
	Card Access Reader B = Barcode W = Wiegand P = Proximity M = Mag Stripe F = Elevator Floor Call H = Elevator Hall Call T = Token S = Smart Card		
	Biometrics Access Control Device H = Hand Geometry F = Finger Print V = Voice R = Eye Retina I = Eye Iris		
			3. ANNUNCIATION: CONSOLE/PANEL Strip (Tallyroll) Printer
			Printer
			Time Clock with Card Reader
			Central Processing Unit
			CRT (cathode ray tube/display)
			Static Map Display (for dynamic map display, use CRT symbol)
			Keyboard
			Jeweled Signal Light
			Panel Light Indicator (R = Red, A = Amber, W = White, V = Violet, G = Green, Y = Yellow, B = Blue, O = Orange)
			Multiplex Panel
			Panel Sound Indicator
			Panel Sound and Light Indicator

	Reset
	Push-Button, Momentary/Make (circuit closing)
	Time Delay Module
	Control Device Module, Door Release
	End-of-Line Device Module
10K Ω	Resistance (Ohms) (indicate value; that is, 10 000 Ω)
K	Thousands
	Dry Contacts, Set
	Contacts with Current
	Power Switch
	Field Panel T: C = Card Reader A = Alarm
	Control Panel T: B = Burglar F = Fire P = Perimeter D = Door
	Central Processing Unit
	Keyboard
	Printer
	Power Supply T: L = Lock C = Camera P = Panel I = Intercom







4. ANNUNCIATION: DEVICES
Annunciation Device, Generic



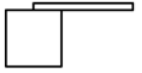
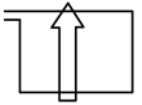

	Buzzer
	Generic Bell
	Generic Chime
	Generic Security Horn (differentiate from fire horn; use also for local alarm)
	Audio Device T: L = Lock C = Camera I = Intercom

5. BARRIERS AND VEHICLE CONTROLS



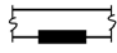

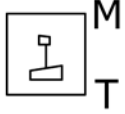
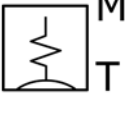
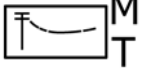
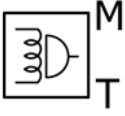





	Generic Fence (reference type in specification or schedule) X: (Fence Type) Y: (Sensor Type, see below)
	Generic Masonry (reference type in specification or schedule) X: C = Chain Link; W = Welded Mesh; B = Barbed Top; R = Razor Ribbon Y: E = Electrostatic; T = Taut Wire; V = Vibration
	Ditch Barrier
	Ditch and Berm Barrier
	Roll-Up Gate
	Sliding Gate
	Swing Gate
	Traffic Arm
	Traffic Lights (use "M" for miniature)
	Generic Vehicle Sensor (reference specification or schedule for type)
	Tire Treadle
	Security Grill with Emergency Release









	Security Grill
	Generic Security Screen
	Repair/Secure Window Operator (use "R" for repair, "S" for security)
	Turnstile
	Revolving Door
	Traffic Arm
	Vehicle Loop Detector
	Security Window Screen T: S = Shade B = Blind (see Section 10 for alarm screen)

	Flush Mount Panel Board/Cabinet
	Surface Mount Panel Board/Cabinet
	Intercom T: M = Master S = Substation
	Two-Way Radio Microphone
	Cellular Transmitter
	Telephone Dialer T: D = Digital Communicator V = Voice Dialer
	Fiber Optic Module T: Tx = Transmitter R = Receiver T = Transceiver











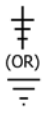
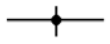



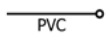

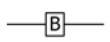

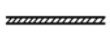

6. COMMUNICATIONS

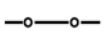
7. ELECTRICAL

	Telephone Handset
	Intercom, Master, Hands-Free (use "S" for slave or sub)
	Intercom, Push-to-Talk
	Generic Speaker (reference specification or schedule for type)
	Nurse Station, Master, Wall Mount (use "D" for desk mount)
	Nurse Call System Device, Generic
	Paging System Device, Generic
	Private Telephone System Device, Generic
	Public Telephone System Device, Generic
	Two-Way Radio Base Station

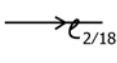
	Resistor
	End-of-Line Device
	Amplifier
	Antenna
	Antenna, Loop
	Battery
	Stand-By Battery
	Capacitor
	Circuit Breaker

 **F967 – 03 (2011)**

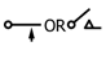
	Ground		Intersection, Connection
	Circuit Return, Common		Conduit Run, Exposed, Turn Down (rigid steel—1 in.)
	Circuit Return, Frame		Conduit Run, Exposed, Armored
	Relay, Normally Open		Conduit Run, Concealed, Turn Up (EMT)
	Relay, Normally Closed		Conduit Run, Exposed, Turn Up (PVC)
	Relay		Booster
	Transformer		Shielded Cable
	Transformer (on floor plan)		Coaxial Cable
	Rectifier		Conductor, Twisted Pair
	Diode		Conductor, Security System (4 conductors, No. 18 AWG)
	Visual Signaling Device		Fiber Optic Cable
	Fuse		Local Radio Signal Link
	Motor		Long Range Radio Signal Link
	Generator		Power Panel (OR) EP
	Junction Box, in Ceiling		Home Run, 2 Conductors, 18 AWG (number of arrows indicates number of circuits)
	Junction Box, Wall		Feeder
	Electrical Outlet, Wall, Duplex		Manhole
	Triplex Receptacle		Rotary Switch
	Intersection, No Connection		Toggle Switch, SPST
			Toggle Switch, SPDT
			Nonlocking, Momentary Circuit Closing (make)

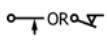
 Nonlocking, Momentary Circuit Opening (break)

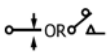
 Transfer

 Locking, Circuit Closing (make)

 Locking, Circuit Opening (break)

 Form A, SPST, N.O.

 Form B, SPST, N.C.

 Form C, SPDT

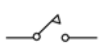
 SPST (Single-Pole, Single-Throw)

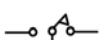
 SPDT (Single-Pole, Double-Throw)

 DPST (Double-Pole, Single-Throw)

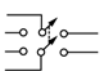
 DPDT (Double-Pole, Double-Throw)

8. LIGHTING

 Incandescent Light Fixture, Flush, Ceiling Mount

 Incandescent Light Fixture, Flush, Wall Mount

 Incandescent Light Fixture, Surface, Ceiling Mount

 Incandescent Light Fixture, Surface, Wall Mount

 Fluorescent Fixture, Ceiling Mount

 Dedicated Security Lighting, Low Pressure Sodium (use other designators for other types, that is, MV = mercury vapor)

 Minimum Foot-Candles or Lamberts this Area

 Spotlight/Floodlight

 Outdoor Strobe Light

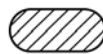
 Illuminate this Area

 Infrared Illuminator

 Street Light, Pole-Mounted

9. MISCELLANEOUS

 Security Container; Safe; File Cabinet

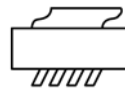
 Document Destroyer

 Safe, Tack-Welded to Structural Member

 Signage

 Bar/Grill/Seal this Location

 Timer

 Gun Port

10. SENSORS

 Generic Volumetric Motion Sensor (Mono)
X = *M* = Microwave
I = Passive IR
U = Ultrasonic
D = Dual Tech











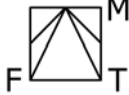



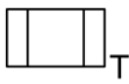
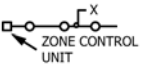



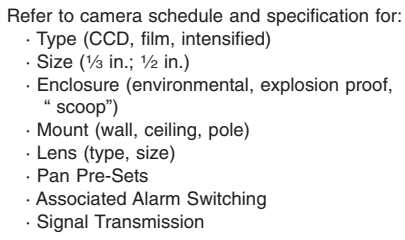













 Generic Volumetric Beam Sensor (Bi-Static)
X = *M* = Microwave
I = Infrared
P = Photo-cell

 Generic Glass Breakage Sensor
T = *A* = Audio
S = Shock

 Capacitance Sensor

 Temperature Sensor

 Pad/Mat Switch

	Bullet-Resistant Polycarbonate Glazing with Alarmed Conductive Layer		Bi-Static Beam Sensor T: M = Microwave I = Infrared F: TX = Transmit RX = Receive
	Water Sensor		Security Screen with Alarm T: S = Shade B = Blind
	Water Motion Sensor		Screening Device T: M = Metal Detector E = Explosives Detector X = X-Ray T = Tag Detector (EAS) A = Access
	Generic Buried Sensor X: S = Seismic L = Leaky Coax M = Magnetic		11. CCTV
	Strain Sensor		Generic Camera X: P = Pan; A = Auto-Pan; PT = Pan/Tilt; C = Concealed Y: F = Fixed; Z = Zoom; S = Split
	Vibration/Shock Sensor (nonfence type)		Refer to camera schedule and specification for: · Type (CCD, film, intensified) · Size (1/8 in.; 1/2 in.) · Enclosure (environmental, explosion proof, "scoop") · Mount (wall, ceiling, pole) · Lens (type, size) · Pan Pre-Sets · Associated Alarm Switching · Signal Transmission
	Sonic Sensor (audible, doppler shift)		Reference Monitor/Switching Schedule or Specifications for Size, Type, Mounting
	Sound Discriminator (responds to frequencies) (see also glass break sensor)		Pan Control
	Listen-in Audio Sensor		Zoom Control
	Radar		Pan-Zoom-Tilt Control
	Sonar		Video Tape Recorder
	Seismic Sensor (local stimuli, point type)		Video Disc Recorder
	Strong Motion Seismic Sensor (earthquake)		Any Control Unit, Generic
	Bank Vault Sensor or Sensor Array		Auto Control Unit, Generic
	Electronic Tag Sensor		Video Motion Detector
	Local Control Unit for Sensors		Screen Splitter (Video Multiplexer)
	Explosive Dye-Pack Antenna		
	Break-Dowell Grid		
	Indicates "Lace this Partition"		
	Motion Detector T: M = Microwave IR = Infrared U = Ultrasonic X = Request-for-Exit D = Dual Technology		



Microprocessor Based Switcher
X = Number of Inputs
Y = Number of Outputs

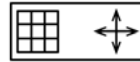

Video Control Keyboard



Distribution Amplifier

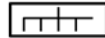

Video Multiplexer



Ground Loop Corrector



Video Motion Detector



Video Switcher Control Keyboard



CCTV Switcher, Passive, Manual

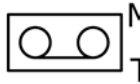

Recorder
T: V = Video
A = Audio
D = Digital



CCTV Switcher, Homing Sequential

12. SWITCHES

Generic Switch

- X: D = Door
- S = Spring Loaded/Deadman
- R = Roll-Up/Overhead Door
- G = Gate
- W = Window/Sliding Door
- F = Footrail
- T = Tamper
- H = Hinge
- P = Plunger/Roller
- L = Level/Tilt/Mercury
- B = Bill/Cash Drawer

(Reference door schedule or specification for gap, size, mounting, balanced, tampered, EOL resistor)



CCTV Switcher, Looping Input, Homing Sequential



Generic Key Switch

- X: S = Shunt
- W = Watch-Tour Station
- D = Door Release
- R = Reset



CCTV Switcher, Bridging Output, Sequential



CCTV Switcher, Looping Input, Bridging Sequential



CCTV Switcher, Auto Alarm Homing Sequential



Generic Key Switch

- X: S = Shunt
- W = Watch-Tour Station
- D = Door Release
- R = Reset



CCTV Switcher, Remote



Keypad Switch



MATV Antenna



Monitor
T: V = Video
D = Data
G = Graphic
M = Multiscreen



Automatic Monitoring Switch

- T: T = Temp
- B = Bal. Mag
- H = Humidity
- W = Water
- L = Latch
- G = Gate

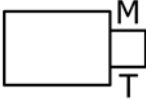

Camera
T: S = Scoop/Wedge
C = Corner
D = Dome
B = Board
E = Environmental

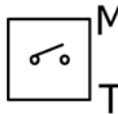

Manually Operated Switch

- T: E = Emergency
- L = Lock
- F = Foot
- M = Mat
- H = Holdup

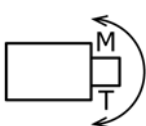



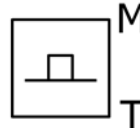



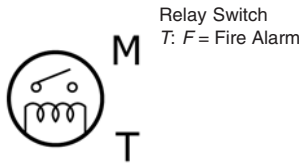











Camera with Pan/Tilt/Zoom
T: D = Dome
E = Environmental























Push Button
T: P = Panic
D = Duress
X = Request-for-Exit
R = Door Release
B = Bell Push



13. DOOR AND LOCKING HARDWARE

-  Sliding Door
-  Lock (see specification for type)
-  Roll-Up Door
-  Security Curtain, Sliding/Rolling
-  Security Curtain, Roll-Down
-  Vault Door
-  Vault Door with Day Door
-  Bullet-Resistant Construction
-  Door with Vision Panel
-  Interlock Indication
-  Door View Lens Viewer
-  Hatch Door
-  Multi-Point Locking Door
-  Barricade Bar
-  Electromagnetic Lock
X: D = Door Switch
-  Electrified Lock Set
X: F = Fail-Safe
S = Fail-Secure
-  Replace/Install Hinge (use "R" for repair, "I" for install)
-  Pin Hinge Pin or Replace with Security Hinge

-  Electric Hinge
-  Concealed Hinge
-  Hinge Switch, Bullet-Nose Type
-  Electric Strike
X: F = Fail-Safe
S = Fail-Secure
-  Electric Bolt/Latch
X: F = Fail-Safe
S = Fail-Secure
-  Security Fastener, Generic
-  Hasp Assy
-  Padlock
-  Mechanical Keypad Door Lock
-  Replace/Install Door (use "R" for repair, "I" for install)
-  Replace/Install Frame (use "R" for repair, "I" for install)
-  Replace/Install Door Closer (use "R" for repair, "I" for install)
-  Replace/Install Center Mullion
-  Escutcheon
-  Astragal
-  Replace/Install Security Cylinder (use "R" for repair, "I" for install)
-  Key Lock
-  Secure Transom
-  Door Operator
-  Automatic Opener Actuation Pad

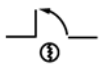

Automatic Opener, Microwave Type



Panic Hardware



Vertical Bolts in Header and Floor



Door Lock, Mortised (use "R" for rimlock)



With Local Alarm



With Cylinder Lock, Blank One Side



With Remote Alarm



With Local and Remote Alarm



With Cylinder Lock and Lever or Thumb Lever on One Side



Direction of Always Open



Direction of Always Locked



Key-In-Knob, Both Sides



Deadbolting Lockset



Positive Latching Lockset



Positive Latching and Locking Lockset



Combination Deadbolting and Positive Latching with Dual Action Thumb Lever One Side and Cylinder on Other



Deadbolt



Deadlatch



Cam Lock

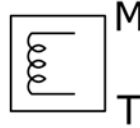

Electronic Lock
T: *M* = Magnetic
S = Strike
L = Latch Set
H = Hybrid
D = Deadbolt



Exit Device
T: *E* = Electrified
M = Mechanical
D = Delayed Egress
X = High Security

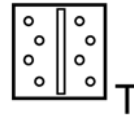

Power Transfer Hinge
T: 2 = Two-Wire
 4 = Four-Wire, etc.

ANNEX

(Mandatory Information)

A1. SAMPLE COMBINATION DEVICES

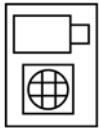

Video Intercom

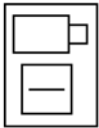

Camera with Card Reader

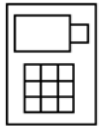

Camera with Keypad



Video Intercom Master
T: R-With Door Release

APPENDIX

(Nonmandatory Information)

X1. COMMENTARY

X1.1 This commentary provides a brief history and rationale for a significant revision to this practice. This revision expanded the focus and intent of this standard beyond a practice for manual drafting to encompass computer aided design (CAD). This commentary also provides a technical source of reference for additional information related to, but beyond the scope of, this practice.

X1.2 The original practice was developed with the intent of providing consistency in the engineering symbols used for depiction of security system layout and design on architectural and engineering drawings, as detailed in the scope. At the time of conception, manual generation of these drawings was the most commonly used method, and the community of large system designers that would have use for such standard

symbols was relatively small.

X1.3 Over time, advances in technology enabled effective generation of architectural and engineering drawings through CAD, as well as ancillary uses and linkages for the digitally stored symbols. As this capability and the security industry grew, numerous sets of new symbols were found on CAD drawings with considerable inconsistency.

X1.4 In 1994 the Security Industry Association (SIA) and the International Association of Professional Security Consultants (IAPSC) proposed an update to this practice that would standardize the CAD symbols. It was decided that the CAD symbols should be added to the practice and should correlate to the manual symbols, since both CAD and manual drawing generation would continue to be used in actual practice. The

CAD symbols were developed as icons, each intended to reflect a visual image associated with the security device it represents.

X1.5 The SIA/IAPSC Architectural Graphics Joint Standards Subcommittee works to maintain reflection of the current state of the art in security products through CAD symbols, and

provides the paper depiction of the CAD symbols as a single source of cross reference in this practice. Additional information on CAD symbol libraries, associated CAD files, and additional CAD layers may be obtained through the SIA/IAPSC Subcommittee.

ASTM International takes no position respecting the validity of any patent rights asserted in connection with any item mentioned in this standard. Users of this standard are expressly advised that determination of the validity of any such patent rights, and the risk of infringement of such rights, are entirely their own responsibility.

This standard is subject to revision at any time by the responsible technical committee and must be reviewed every five years and if not revised, either reapproved or withdrawn. Your comments are invited either for revision of this standard or for additional standards and should be addressed to ASTM International Headquarters. Your comments will receive careful consideration at a meeting of the responsible technical committee, which you may attend. If you feel that your comments have not received a fair hearing you should make your views known to the ASTM Committee on Standards, at the address shown below.

This standard is copyrighted by ASTM International, 100 Barr Harbor Drive, PO Box C700, West Conshohocken, PA 19428-2959, United States. Individual reprints (single or multiple copies) of this standard may be obtained by contacting ASTM at the above address or at 610-832-9585 (phone), 610-832-9555 (fax), or service@astm.org (e-mail); or through the ASTM website (www.astm.org). Permission rights to photocopy the standard may also be secured from the Copyright Clearance Center, 222 Rosewood Drive, Danvers, MA 01923, Tel: (978) 646-2600; <http://www.copyright.com/>