



Standard Test Method for Seal Strength of Flexible Barrier Materials¹

This standard is issued under the fixed designation F88/F88M; the number immediately following the designation indicates the year of original adoption or, in the case of revision, the year of last revision. A number in parentheses indicates the year of last reapproval. A superscript epsilon (ϵ) indicates an editorial change since the last revision or reapproval.

1. Scope

1.1 This test method covers the measurement of the strength of seals in flexible barrier materials.

1.2 The test may be conducted on seals between a flexible material and a rigid material.

1.3 Seals tested in accordance with this test method may be from any source, laboratory or commercial.

1.4 This test method measures the force required to separate a test strip of material containing the seal. It also identifies the mode of specimen failure.

1.5 The values stated in either SI units or inch-pound units are to be regarded separately as standard. The values stated in each system may not be exact equivalents; therefore, each system shall be used independently of the other. Combining values from the two systems may result in non-conformance with the standard.

1.6 *This standard does not purport to address all of the safety concerns, if any, associated with its use. It is the responsibility of the user of this standard to establish appropriate safety and health practices and determine the applicability of regulatory limitations prior to use.*

2. Referenced Documents

2.1 *ASTM Standards:*²

[D882 Test Method for Tensile Properties of Thin Plastic Sheeting](#)

[E171 Practice for Conditioning and Testing Flexible Barrier Packaging](#)

[E691 Practice for Conducting an Interlaboratory Study to Determine the Precision of a Test Method](#)

3. Terminology

3.1 Definitions:

¹ This test method is under the jurisdiction of ASTM Committee F02 on Flexible Barrier Packaging and is the direct responsibility of Subcommittee F02.20 on Physical Properties.

Current edition approved Nov. 1, 2015. Published December 2015. Originally approved in 1968. Last previous edition approved in 2009 as F88/F88M – 09. DOI: 10.1520/F0088_F0088M-15.

² For referenced ASTM standards, visit the ASTM website, www.astm.org, or contact ASTM Customer Service at service@astm.org. For *Annual Book of ASTM Standards* volume information, refer to the standard's Document Summary page on the ASTM website.

3.1.1 *average seal strength, n*—average force per unit width of seal required to separate progressively a flexible material from a rigid material or another flexible material, under the conditions of the test.

3.1.1.1 *Discussion*—The average force normally is calculated by the testing machine from the digitized plot of force versus grip travel. The plot starts from zero force after slack has been removed from the test strip. The initial ramp-up from zero to the force level required to peel the seal is not indicative of seal strength, and data from that part of the curve should not be included in the calculation of average strength, nor should the return to zero following complete failure of the specimen. The amount of data actually discarded on each end of the measured seal-profile curve must be the same for all tests within any set of comparisons of average seal strength (see 6.1.1 and 9.8.1).

3.1.2 *flexible, adj*—indicates a material with flexural strength and thickness permitting a turn back at an approximate 180 degree angle.

3.1.3 *maximum seal strength, n*—maximum force per unit width of seal required to separate progressively a flexible material from a rigid material or another flexible material, under the conditions of the test.

4. Significance and Use

4.1 Seal strength is a quantitative measure for use in process validation, process control, and capability. Seal strength is not only relevant to opening force and package integrity, but to measuring the packaging processes' ability to produce consistent seals. Seal strength at some minimum level is a necessary package requirement, and at times it is desirable to limit the strength of the seal to facilitate opening.

4.1.1 The maximum seal force is important information, but for some applications, average force to open the seal may be useful, and in those cases also should be reported.

4.2 A portion of the force measured when testing materials may be a bending component and not seal strength alone. A number of fixtures and techniques have been devised to hold samples at various angles to the pull direction to control this bending force. Because the effect of each of these on test results is varied, consistent use of one technique (Technique A,

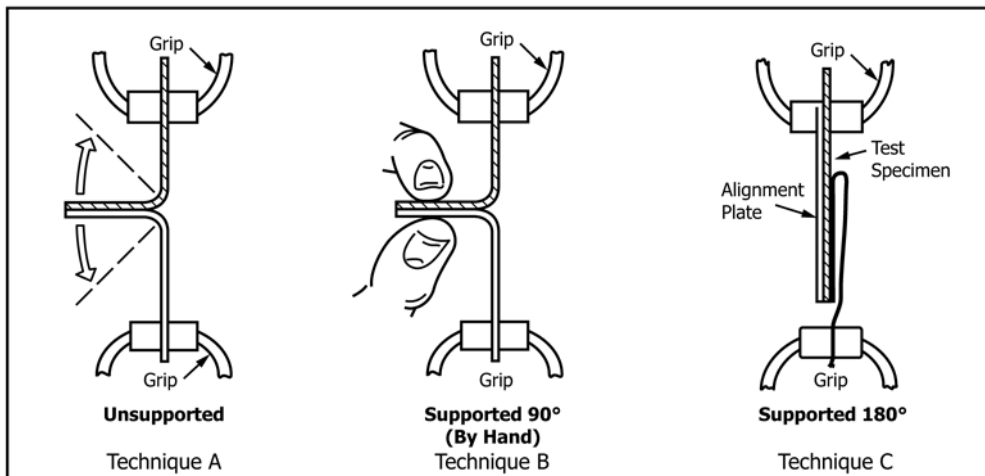

FIG. 1 Tail Holding Methods

Technique B, or Technique C) throughout a test series is recommended. Examples of fixtures and techniques are illustrated in Fig. 1.

4.2.1 *Technique A: Unsupported*—Each tail of the specimen is secured in opposing grips and the seal remains unsupported while the test is being conducted.

4.2.2 *Technique B: Supported 90° (By Hand)*—Each tail of the specimen is secured in opposing grips and the seal remains hand-supported at a 90° perpendicular angle to the tails while the test is being conducted.

4.2.3 *Technique C: Supported 180°*— The least flexible tail is supported flat against a rigid alignment plate held in one grip. The more flexible tail is folded 180° over the seal and is held in the opposing grip while the test is being conducted.

5. Interferences

5.1 The value obtained for seal strength can be affected by properties of the specimen other than seal strength. These interferences are discussed in the annex.

6. Apparatus

6.1 *Tensile Testing Machine*—A testing machine of the constant rate-of-jaw-separation type. The machine shall be equipped with a weighing system that moves a maximum distance of 2 % of the specimen extension within the range being measured. The machine shall be equipped with a device for recording the tensile load and the amount of separation of the grips; both of these measuring systems shall be accurate to ± 2 %. The rate of separation of the jaws shall be uniform and capable of adjustment from approximately 8 to 12 in. [200 to 300 mm]/min. The gripping system shall be capable of minimizing specimen slippage and applying an even stress distribution to the specimen.

6.1.1 If calculation of average seal strength is required, the testing machine system shall have the capability to calculate its value over a specified range of grip travel programmable by the operator. Preferably, the machine shall have the capability also to plot the curve of force versus grip travel.

6.2 *Specimen Cutter*, conforming to the requirements of 5.4 of Test Methods D882, sized to cut specimens to a width of 0.984 in. [25 mm], 0.591 in. [15 mm], or 1.00 in. [25.4 mm]. Tolerance shall be ± 0.5 %.

7. Sampling

7.1 The number of test specimens shall be chosen to permit an adequate determination of representative performance.

7.2 Testing of samples with visual defects or other deviations from normality may or may not be appropriate depending on the purpose of the investigation. Indiscriminate elimination of defects can bias results.

8. Aging and Conditioning

8.1 In the absence of information showing that heat seal strength stability of the materials under test is reached in shorter times, condition and test sealed materials in accordance with Specification E171, with a minimum conditioning time of 40 h or longer if shown to be required to reach stability.

8.2 Heat seal conditioning periods may be shortened to times determined by experimentation as sufficient to achieve seal strength stability.

8.3 Modification of conditioning practices may be necessary to meet specific test objectives, such as the measurement of seal strength at specified storage or handling temperature.

9. Procedure

9.1 Calibrate the tensile machine in accordance with the manufacturer's recommendations.

9.2 Prepare sealed test specimens for testing by cutting to the dimensions shown in Fig. 2. Edges shall be clean-cut and perpendicular to the direction of seal. Specimen legs may be shorter than shown, depending on the grip dimensions of the testing machine.

9.3 Adhering to one tail-holding technique, clamp each leg of the test specimen in the tensile testing machine. The sealed

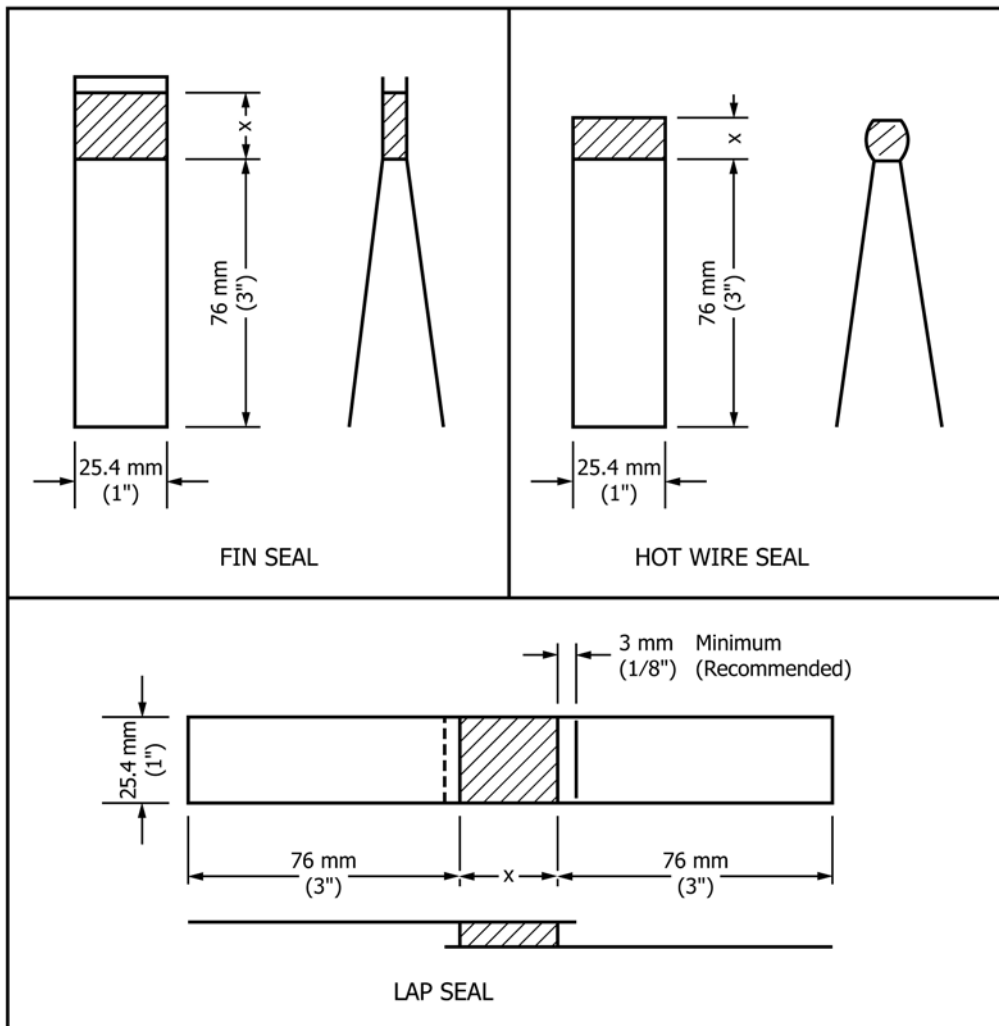

NOTE 1—Seal dimension marked X varies with sealer configuration.

FIG. 2 Recommended Specimen Dimensions

area of the specimen shall be approximately equidistant between the grips. Recommended distance between grips (initial unconstrained specimen length) is:

Fin and Hot-Wire Seals		
Highly ^A extensible materials	0.39 in.	[10 mm]
Less ^A extensible materials	1.0 in.	[25 mm]
Lap Seals	X + 10 mm ^B	

^A Grip separation distance is recommended to be limited for highly extensible materials (100 + % elongation at seal failure) to minimize interferences (see annex).

^B Refer to Fig. 2 for definition of X.

9.4 Center the specimen laterally in the grips. Align the specimen in the grips so the seal line is perpendicular to the direction of pull, allowing sufficient slack so the seal is not stressed prior to initiation of the test.

9.5 A significant difference in measured seal strength has been shown to result, depending on the orientation of a fin-seal tail during the test. The test report should indicate the details of any technique used to control tail orientation.

9.6 The seal shall be tested at a rate of grip separation of 8 to 12 in./min [200 to 300 mm/min].

9.7 For each cycle, report the maximum force encountered as the specimen is stressed to failure and identify the mode of specimen failure.

9.8 If the test strip peels apart in the seal area, either by adhesive failure, cohesive failure, or delamination, the average peel force may be an important index of performance and should be measured by the testing machine as a part of the test cycle.

9.8.1 Follow the machine manufacturer's instructions to select the desired algorithm for calculating average seal strength. Fig. 3 illustrates the effect of an algorithm that uses data only from the central 80 % of the curve to calculate the average.

9.8.2 If the test strip does not peel significantly in the seal area and failure is largely by breaking, tearing, or elongation of the substrate material, average force to failure may have little

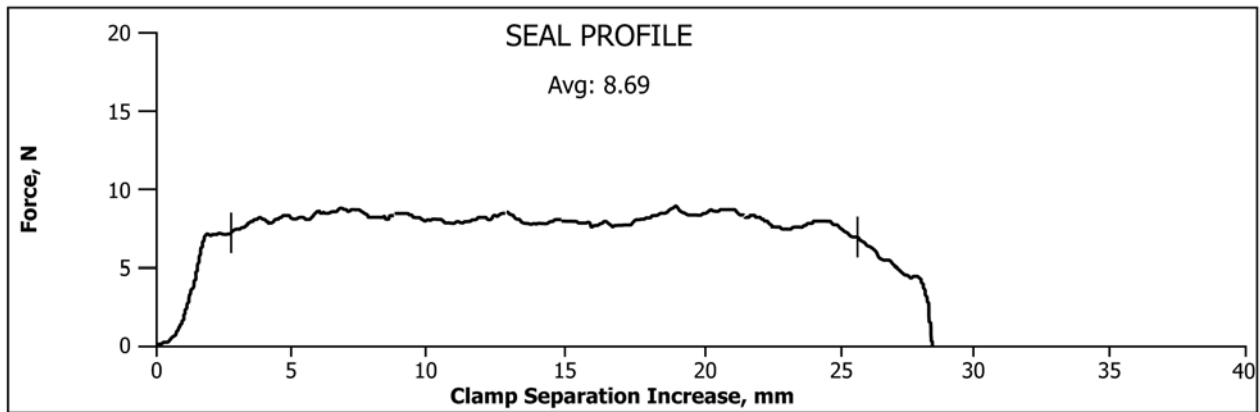

MARKERS ON SEAL PROFILE PLOT AT 10% AND 90% ESTABLISH DATA WINDOW OF 80% FOR CALCULATION

FIG. 3 Calculation of Average Seal Strength

significance in describing seal performance and should not be reported in such cases (see Annex A1.1).

9.9 A plot of force versus grip travel may be useful as an aid in interpretation of results. In those cases, the testing machine should be programmed to generate the plot.

9.10 Other properties, such as energy to cause seal separation, may be appropriate in cases where grip travel results only in peel. When other failure modes (elongation, break, tear, delamination (when not a designed peel seal separation mode) or other) are present in addition to peel of the seal, energy, and other functions must be interpreted with caution.

10. Report

10.1 Report the following:

- 10.1.1 Complete identification of material being tested.
- 10.1.2 Equipment and test method or practice used to form seals, if known.
- 10.1.3 Equipment used to test seals.

TABLE 1 Materials and Techniques

Test Series "A" (MAXIMUM Values)
Heat Seal Coated 50# Basis Weight Paper sealed to Film (48 ga. PET/2 mil LDPE) Supported 90° @ 12 in./min Unsupported @ 12 in./min Unsupported @ 8 in./min
Test Series "B" (Both MAXIMUM Values and AVERAGE Peel Values were reported)
Uncoated 1073B Tyvek sealed to Film (48 ga. PET/2 mil LDPE) Supported 90° @ 12 in./min Unsupported @ 12 in./min Supported 180° @ 12 in./min Reverse direction of materials in grips @ 12 in./min
Test Series "C" (MAXIMUM Values)
Coex HDPE 3 mil film with peelable sealant layer sealed face-to-face Foil Composite 5 mil with same peelable sealant surface sealed face-to-face Unsupported @ 12 in./min Supported 180° @ 12 in./min

TABLE 2 Test Equipment

Manufacturer	Models	Load Cell	
		lb	N
Dillon	AFG-50N	11.2	50
Instron	4464, 5500R, 5564,	1124, 112.4,	5 kN, 500,
	5565, S5R1123,	22.5, 11.2, 2	100, 50, 9
	4442, MN-44		
Lloyd Instruments	1300-36	22.4	100
MTS Sintech Renew	4204	25	111.2
Test Resources	2000ZR	25	111.2
Thwing Albert	EJA	11.2	50
Vinatoru Enterprises	CCT, HST	11.2	50

10.1.4 Ambient conditions during tests; temperature and humidity.

10.1.5 Grip separation rate.

10.1.6 Initial grip separation distance.

10.1.7 Seal width.

10.1.8 Machine direction of material in relation to direction of pull may be noted, if known and relevant to the test outcome.

10.1.9 Force (strength) values to three significant figures.

10.1.10 Technique of holding the tail (Technique A, B, or C) and any special fixtures used to hold specimens.

10.1.11 If the seal is made between two different materials, record which material is clamped in each grip.

10.1.12 Number of specimens tested and method of sampling.

10.1.13 Any other pertinent information that may affect test results.

10.1.14 Visual determination of mode of specimen failure. Frequently more than one mode will occur in the course of failure of an individual strip. Record all modes observed. A suggested classification of modes is (see Fig. 4):

- Adhesive failure of the seal; peel.
- Cohesive failure of the material.
- Break or tear of material in seal area or at seal edge.
- Delamination of surface layer(s) from substrate.
- Elongation of material.
- Break or tear of material remote from seal.

SEAL SEPARATION MODES

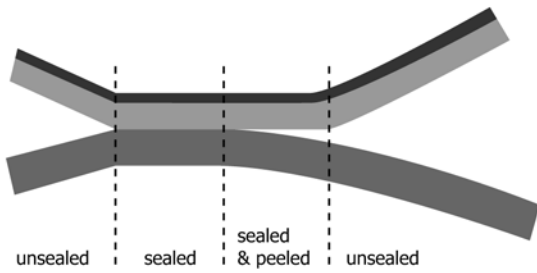

ADHESIVE PEEL

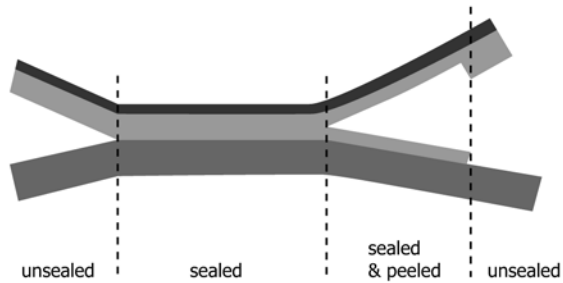

COHESIVE PEEL

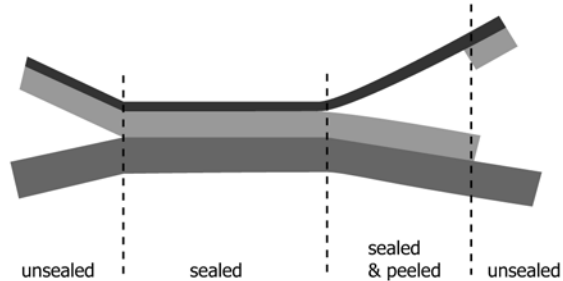

DELAMINATION

INTERFERENCES

Though the diagrams show only one web being affected, it is possible for either or both webs to partially or fully exhibit interferences. Delamination, when not a designed seal separation mode, is an interference.

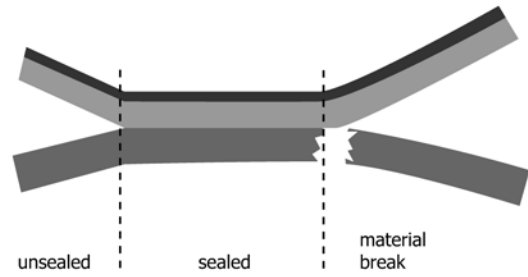

MATERIAL BREAK

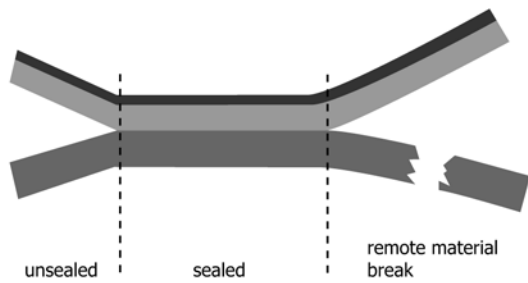

MATERIAL BREAK (REMOTE)

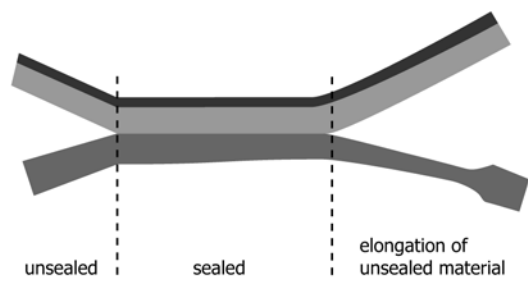

MATERIAL ELONGATION

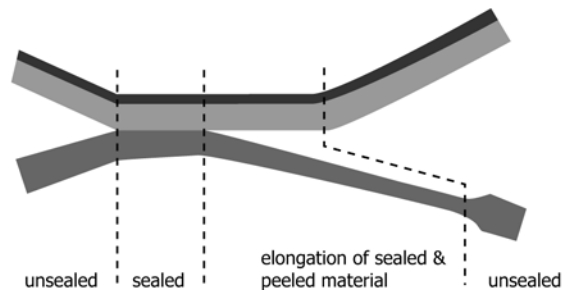

PEEL WITH ELONGATION

NOTE 1—Schematic representation of seal failure modes for seals between two webs. No diagram is included for systems including an adhesive as a third component.

FIG. 4 Test Strip Failure Modes

10.1.15 Maximum force encountered as each specimen is stressed to failure, expressed preferably in Newtons/meter or lbf/in. of original specimen width. Gmf/in. and lbf/in. are commonly used.

10.1.16 *Average Peel Force*, if applicable (see 9.8)—If this measurement is reported, a statement of the method or algorithm used to calculate the average should be included.

10.1.17 Plot of force versus grip travel, if deemed significant in interpretation of results.

10.1.18 Other data not compromised by interferences, if such data are relevant to the specific test purpose.

10.1.19 Any statistical calculation deemed appropriate (most commonly mean, range, and standard deviation).

11. Precision and Bias

11.1 *Precision*—A round robin was conducted using Practice E691 as a guide, involving 18 laboratories measuring a total of 1980 samples distributed over three different test groups of six laboratories each.³ In order to maintain a focus on testing the method itself, laboratory samples were used to limit the amount of variation in the seals produced. Description of materials measured and methods used are listed in Table 1. Seven different brands of tensile testing equipment were used to collect information. The model identifications and load cell sizes are listed in Table 2. Statistical summaries of repeatability

³ Supporting data have been filed at ASTM International Headquarters and may be obtained by requesting Research Report RR:F02-1023.

(within a laboratory) and reproducibility (between laboratories) are listed in Table 4 for SI units and Table 3 in units of pounds per inch. Fig. 5 is graphical depictions of data.

11.2 *Concept of “r” and “R” in Tables 4 and 3*— If S_r and S_R have been calculated from a large enough body of data, and for test results that are averages from testing 10 to 30 specimens (see Note 1) for each test result, then the following applies:

NOTE 1—Repeatability and reproducibility comparisons for smaller sample size (n=10) can be found in the Appendix section of this test method.

11.2.1 Repeatability “r” is the interval representing the critical difference between test results for the same material and method, obtained by the same operator using the same equipment on the same day in the same laboratory. Test results shall be deemed to be not equivalent if they differ by more than the “r” value for that material or method.

11.2.2 Reproducibility “R” is the interval representing the critical difference between test results for the same material and method, obtained by different operators using the different equipment in different laboratories, not necessarily on the same day. Test results shall be deemed to be not equivalent if they differ by more than the “R” value for that material or method.

11.3 Any judgment in accordance with 11.2.1 or 11.2.2 will have approximately 95 % (0.95) probability of being correct.

11.4 *Bias*—There are no recognized standards by which to estimate the bias of this test method.

TABLE 3 r and R Summary (Inch-Pound Units)

NOTE 1—In accordance with Practice E691, enter the larger of the values obtained by the use of (equation for S_r) and (equation for S_R) as the final value of S_R to be used for precision statements.

Units: lb/in.	S_r	S_R	r	R	Grand Avg
A Supported 90°	0.0396	0.0473	0.1109	0.1324	0.957
A Unsupported at 12 in./min	0.0929	0.1286	0.2601	0.3602	1.424
A Unsupported at 8 in./min	0.1063	0.1488	0.2977	0.4166	1.417
B PEAK 90°	0.2629	0.2539	0.7361	0.7361 ^A	0.923
B AVG 90°	0.1600	0.1599	0.4480	0.4480	0.684
B PEAK Unsupported	0.2683	0.2630	0.7513	0.7513 ^A	1.709
B AVG Unsupported	0.2510	0.2492	0.7029	0.7029 ^A	1.453
B PEAK 180°	0.2977	0.3292	0.8335	0.9218	3.239
B AVG 180°	0.3070	0.3567	0.8596	0.9988	2.990
B PEAK 180° Reverse	0.5536	0.5971	1.5501	1.6720	1.464
B AVG 180° Reverse	0.2560	0.2451	0.7167	0.7167 ^A	0.936
C 3 mil Film Unsupported	0.0605	0.1059	0.1695	0.2966	1.695
C 3 mil Film 180°	0.1786	0.3003	0.5001	0.8408	3.463
C 5 mil Foil Unsupported	0.0382	0.0272	0.1069	0.2051	1.209
C 5 mil Foil 180°	0.3164	0.3476	0.8859	0.9731	4.569

^A Per Practice E691: “Enter the larger of the values obtained by the use of (equation for s_r) and (equation for s_R) as the final value of s_R to be used for precision statements.”

TABLE 4 r and R Summary (SI Units)

NOTE 1—In accordance with Practice E691, enter the larger of the values obtained by the use of (equation for S_r) and (equation for S_R) as the final value of S_R to be used for precision statements.

NOTE 2—The values stated were converted from inch-pound units.

Units: N/25.4 mm	S_r	S_R	r	R	Grand Avg
A Supported 90°	0.1761	0.2103	0.4932	0.5889	4.2569
A Unsupported at 12 in./min	0.4132	0.5722	1.1568	1.6021	6.3343
A Unsupported at 8 in./min	0.4729	0.6618	1.3242	1.8529	6.3031
B PEAK 90°	1.1694	1.1293	3.2742	3.2742 ^A	4.1057
B AVG 90°	0.7117	0.7112	1.9927	1.9927	3.0426
B PEAK Unsupported	1.1936	1.1700	3.3421	3.3421 ^A	7.6020
B AVG Unsupported	1.1167	1.1084	3.1267	3.1267 ^A	6.4633
B PEAK 180°	1.3242	1.4643	3.7077	4.1002	14.4078
B AVG 180°	1.3656	1.5868	3.8236	4.4431	13.3002
B PEAK 180° Reverse	2.4625	2.6562	6.8950	7.4373	6.5122
B AVG 180° Reverse	1.1386	1.0901	3.1880	3.1880 ^A	4.1635
C 3 mil Film Unsupported	0.2693	0.4712	0.7539	1.3194	7.5397
C 3 mil Film 180°	0.7945	1.3357	2.2245	3.7400	15.4042
C 5 mil Foil Unsupported	0.1699	0.3203	0.4757	0.8968	5.3779
C 5 mil Foil 180°	1.4074	1.5460	3.9406	4.3287	20.3239

^A Per Practice E691: "Enter the larger of the values obtained by the use of (equation for s_r) and (equation for s_R) as the final value of s_R to be used for precision statements."

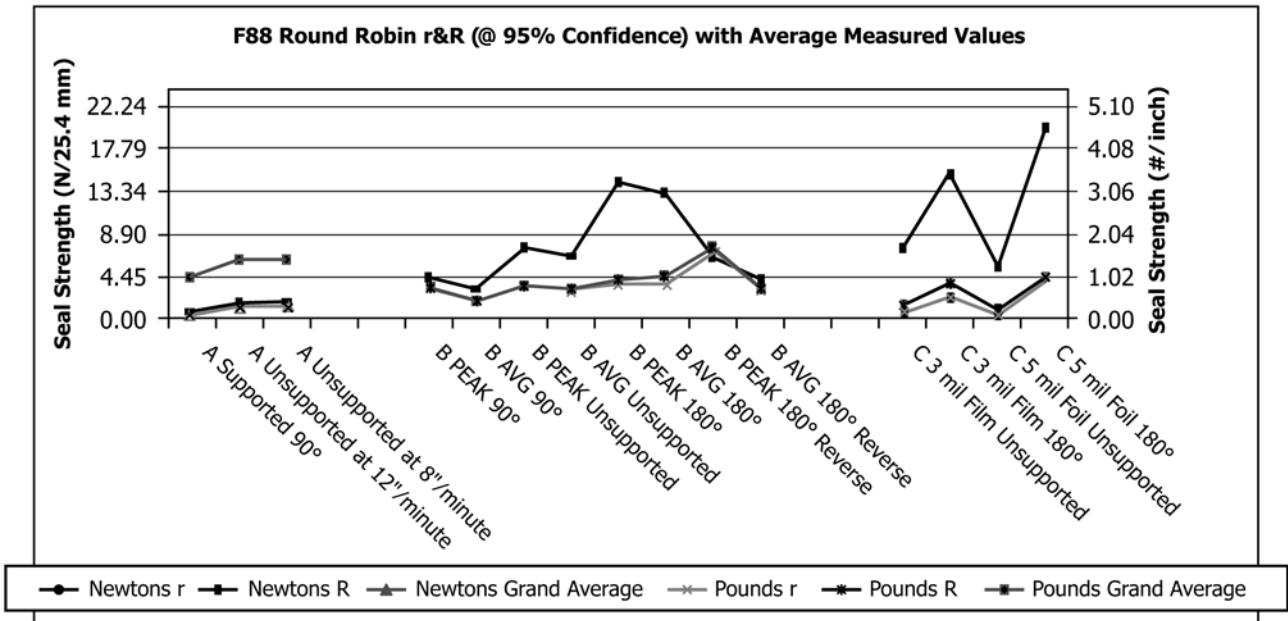

FIG. 5 F88 Round Robin r & R (at 95 % confidence) With Average Measured Values

ANNEX
(Mandatory Information)
A1. INTERFERENCES

A1.1 *Failure Mode*—The objective of this test method is to measure the strength of seals in flexible barrier materials. The intent is to determine seal strength by measuring force required to peel a seal apart while pulling on the ends of a strip of material containing the seal. However, the pulling process may or may not result in the desired mode of strip failure. During the test cycle, the grips are moved apart at a set rate while the force required to extend the ends of the strip is continuously monitored. Extension of the specimen ends can cause one or a combination of the following effects within the specimen itself:

Break or tear of material at edge of seal.
 Elongation of the material.
 Break or tear of material remote from seal.

A1.1.1 These effects are due to failure of the material itself and must be identified as such in the test report. These effects are typical for weld seal applications. However, for peelable applications, these effects are interferences that can prevent the method from measuring the true strength of the seal.

A1.1.2 Seal characteristics such as deformation, shrinkage, and burnthrough can affect the outcome of the test.

A1.2 *Effect of Material Elongation on Rate of Peel*—Another interference is caused by elongation of the material during the test. If the test strip stretches or delaminates during

grip travel, the rate of peel will be lower than that calculated from the grip separation rate. In this instance, the ratio of stretch to peel is unknown and may vary during the test. The rate of peel is then no longer controlled by the machine. Rate of peel is known to affect measured seal strength value.

A1.3 *Initial Clamp Separation Distance*—Since the material between the seal and the grips can interfere significantly with measurement of seal strength, in accordance with the preceding paragraphs, the initial clamp separation distance should be set at a relatively low value to minimize that potential.

A1.4 *Peel Rate versus Grip Separation Rate*—In peel testing, whenever separation of the grips holding the test strip is translated completely into peeling of the seal, an increase in grip separation of X cm causes an advance of the failure line into the seal of 0.5X cm. The peel rate in this ideal situation is therefore ½ of the grip separation rate. This arithmetic is commonly overlooked, leading to peel rate being incorrectly equated with grip separation rate.

APPENDIX
(Nonmandatory Information)
X1. ILS BACKGROUND, RATIONALE, AND ANALYSIS

X1.1 The Interlaboratory Study (ILS) performed in 2004 to create the data for the statement found in Section 11 Precision and Bias was collected from 18 labs.³ The ASTM F02.3 and F02.6 subcommittees in joint participation ran nearly 2000 samples through tensile test devices that fulfilled the requirements of the apparatus section of this test method. Since the method and the techniques discussed in the standard were the focus of the study the joint subcommittee concluded that the samples should be as close to homogeneous as possible, that is, not production machine samples but controlled laboratory made samples. Therefore they were created using materials from one single lot each, then sealed on a single laboratory sealing machine from each of the three companies volunteering for sample preparation and trimmed to the defined cut size prior to shipping out to the test laboratories and their assigned contacts.

X1.1.1 Three protocols were designed, each using a different material combination. The materials used included a heat seal coated paper material sealed to a film (PET/LDPE), an uncoated Tyvek 1073B material sealed to a film (PET/LDPE)

and a set of material composites (3 mil Film/Film and 5 mil foil/foil) with a peelable sealant surface sealed face-to-face. Each series was designed to identify the effects of variations in the use of the method on the final measured result as well as on repeatability (r) and reproducibility (R). These techniques are listed in Table X1.1.

X1.1.2 The ILStudies were essentially separate and data was not compared from group to group unless changes in technique resulted in common effects to measured values or to r & R. At that point observations could be made as to the effect across material types and uncommon laboratory sources.

X1.1.3 One of the decisions made by the joint committee was on the required sample size needed for assurance of an effective measurement (n=30 versus n=10). It was believed that the greater sample size was necessary to have confidence that data from a destructive test method would result in a statistically accurate statement of variation. This sample size required an extremely high number of samples be made for all laboratories to test all materials and techniques (18 laboratories × 30 samples × 11 techniques). Reducing this number drove the ILS

TABLE X1.1 Series Descriptions

Material 1	Material 2	Method <i>n</i> = 30 each	Moving Jaw	Speed, in./min	Sample Sizes
Series “A” Paper Heat Seal Coated (gripped in moving jaw) 50# basis weight	Film Polyester/polyethylene	Unsupported	Paper	8 in.	n=540 30 × 3 = 90 × 6 labs
		Unsupported		12 in.	
Series “B” Tyvek 1073B (gripped in moving jaw)	Film Polyester/polyethylene	Unsupported	Tyvek	12 in.	n=720 30 × 4 = 120 × 6 labs
		Supported 180°		Film	
		Supported 90°	Samples marked		
		Reverse 180°		Reverse 180°	
Series “C” Peelable Film 3 mils	Peelable Film 3 mils	Unsupported	Samples marked	12 in.	n=360 30 × 2 = 60 × 6 labs
		Supported 180°		12 in.	
Series “C” Peelable Foil composite 5 mils	Peelable Foil composite 5 mils	Unsupported	Samples marked	12 in.	n=360 30 × 2 = 60 × 6 labs
		Supported 180°		12 in.	

NOTE 1—The tail angle of peel (see Fig. 1 Tail Holding Methods) Unsupported, Supported 90° by hand, Supported 180° (All Series).

NOTE 2—Differences in material flexibility: 3-mil film with a peelable sealant layer versus 5-mil foil composite with same peelable surface (Series “C”).

NOTE 3—Incorrect loading: most flexible supported 180° and least flexible material bent back.

NOTE 4—Crosshead speed range: the standard allows for a range of 8 to 12 in./min (Series “A”).

NOTE 5—Data reported as maximum value across the full width of the peel or average value calculated over the center 80 % of peel length (Series “B”).

TABLE X1.2 Sample Size Comparisons

	Table of results with sample sizes n=30					Table of results with sample sizes n=10					$(\frac{10-30}{30}) \cdot 100$	
	<i>S</i> ₃₀	<i>S</i> _{R30}	<i>r</i> ₃₀	<i>R</i> ₃₀	Grand Avg ₃₀	<i>S</i> ₁₀	<i>S</i> _{R10}	<i>r</i> ₁₀	<i>R</i> ₁₀	Grand Avg ₁₀	<i>r</i> _{var%}	<i>R</i> _{var%}
SERIES A												
Supported 90°	0.0396	0.0473	0.1109	0.1324	0.96	0.0466	0.0552	0.1305	0.1546	0.97	17.71%	16.7 %
Unsupported at 12 in./min	0.0929	0.1286	0.2601	0.3601	1.42	0.0891	0.1221	0.2495	0.3419	1.42	-4.1 %	-5.1 %
Unsupported at 8 in./min	0.1063	0.1488	0.2976	0.4166	1.42	0.0954	0.1513	0.2671	0.4236	1.43	-10.3 %	1.7 %
SERIES B												
PEAK 180° Reverse	0.5536	0.5971	1.5501	1.6719	1.46	0.5744	0.5698	1.6083	1.5954	1.44	3.8 %	-4.6 %
AVG 180° Reverse	0.2560	0.2451	0.7168	0.6863	0.94	0.3985	0.3747	1.1158	1.0492	0.98	55.7 %	52.9 %
PEAK 180°	0.2977	0.3292	0.8336	0.9218	3.24	0.2910	0.3058	0.8148	0.8562	3.24	-2.3 %	-7.1 %
AVG 180°	0.3070	0.3567	0.8596	0.9988	2.99	0.2792	0.3119	0.7818	0.8733	3.00	-9.1 %	-12.6 %
PEAK 90°	0.2629	0.2539	0.7361	0.7109	0.92	0.2794	0.3189	0.7823	0.8929	0.94	6.3 %	25.6 %
AVG 90°	0.1600	0.1599	0.4480	0.4477	0.69	0.1572	0.1949	0.4402	0.5457	0.70	1.7 %	21.9 %
PEAK Unsupported	0.2683	0.2630	0.7512	0.7364	1.71	0.2744	0.2751	0.7683	0.7703	1.71	2.3 %	4.6 %
AVG Unsupported	0.2510	0.2492	0.7028	0.6978	1.45	0.2531	0.2541	0.7087	0.7115	1.43	0.8 %	2.00%
SERIES C												
3 mil Film Unsupported	0.0605	0.1059	0.1694	0.2965	1.70	0.0593	0.0984	0.1660	0.2755	1.69	-2.0 %	-7.1 %
5 mil Foil Unsupported	0.0382	0.0720	0.1070	0.2016	1.21	0.0372	0.0711	0.1042	0.1991	1.21	-2.6 %	-1.3 %
3 mil Film 180°	0.1786	0.3003	0.5001	0.8408	3.46	0.1916	0.3435	0.5365	0.9618	3.51	7.3 %	14.4 %
5 mil Foil 180°	0.3164	0.3476	0.8859	0.9733	4.57	0.2965	0.3447	0.8302	0.9652	4.55	-6.3 %	-0.8 %

into the three independent series shown in Table X1.1. In order to resolve the question of accuracy or confidence in the outcome of the analysis, the data was also analyzed by splitting the data into n=30 and n=10 using the first ten data points reported by the laboratories. Results in this study are shown in Table X1.2. Overall, the average measured values of the data series differed by less than 0.1 #/in., the “r” actually resulted in improved levels or less than 5 % increases in 73 % of the tests run over the 3 series. Reproducibility suffered most in the test for incorrect loading (Series B Reverse) and in the 90° supported tail where a difference in 0.02 in Series A accounted for a 17 % increase and in Series B a 0.1 and 0.18 accounted for 22 to 26 %. Looked at another way, Fig. X1.2 plots the average with ±3 standard deviations for each of the sample

sizes overlapped. This visual image suggests that reporting the n=30 result may not show large differences in either reduction or increase in variation.

X1.1.4 By reporting r & R’s from smaller sample sizes, users of this test method would be capable of measuring their agreement to this test method by running fewer samples, that is, 10 versus 30.

X1.1.5 During the run of the ILS data was reviewed for irregularities when compared to other laboratories. Equipment make and model was reported along with load cell size or range of operation in order to determine if this played a part in any variation increase or decrease. Companies were contacted and issues of proper technique were discussed and resolved. After

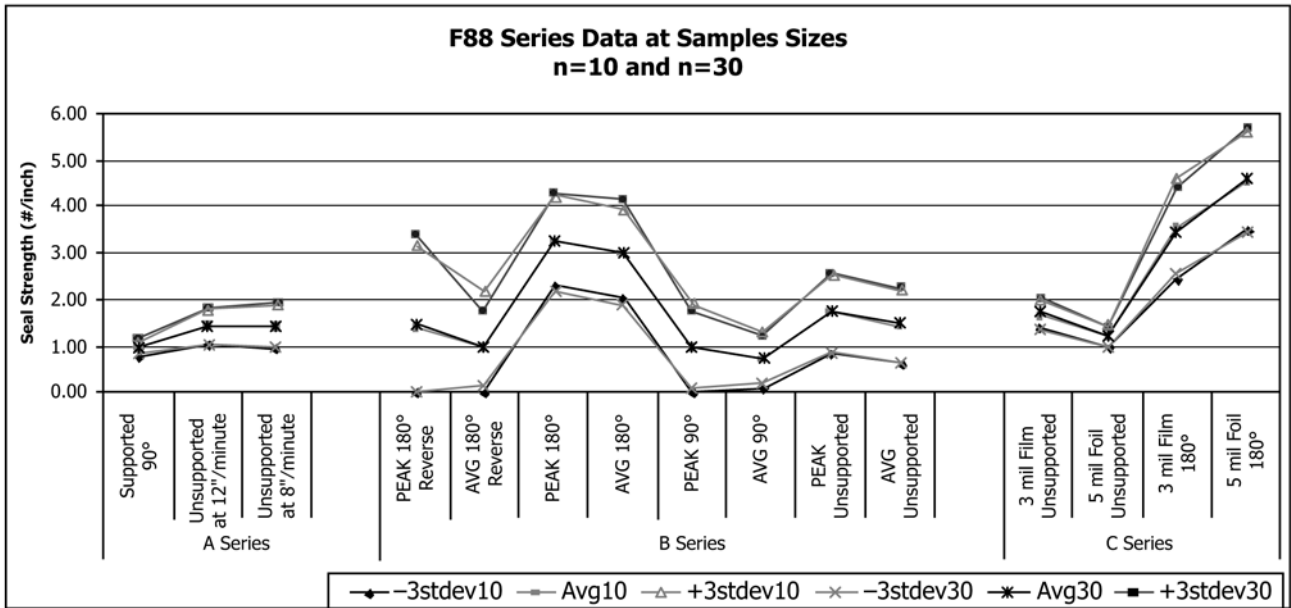

FIG. X1.1 Series Data at Sample Sizes n=10 and n=30.

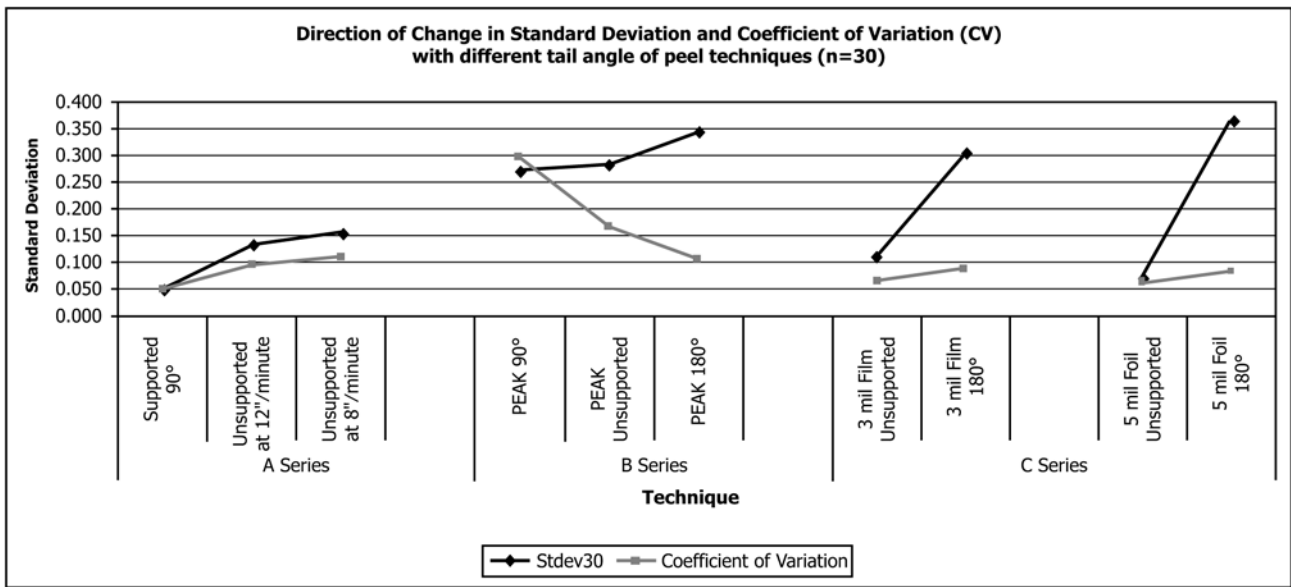

FIG. X1.2 Direction of Change in Standard Deviation with Different Tail Angle of Peel Techniques

a review of the data and the guidance in Practice E691, it was determined that all laboratories and respective data be accepted as proper measures of variability.

X1.1.6 Regarding observations that cross Series material lines, the measures of variation (standard deviation) shown in Fig. X1.1, indicate an increase in variation as techniques change from 90° supported, to unsupported then to 180° supported. It does not appear to be material specific, however the rate of change may be. The measure of Coefficient of

Variation (CV) divides the standard deviation by the average in order to measure the impact of the changes of both measurements. The effect of the increase in variability (standard deviation) is dependent upon the magnitude of the measured values (average). Because the measured values increase substantially in the 180° supported method, the effect of the increase in standard deviation is less than that of the 90° supported data.

ASTM International takes no position respecting the validity of any patent rights asserted in connection with any item mentioned in this standard. Users of this standard are expressly advised that determination of the validity of any such patent rights, and the risk of infringement of such rights, are entirely their own responsibility.

This standard is subject to revision at any time by the responsible technical committee and must be reviewed every five years and if not revised, either reapproved or withdrawn. Your comments are invited either for revision of this standard or for additional standards and should be addressed to ASTM International Headquarters. Your comments will receive careful consideration at a meeting of the responsible technical committee, which you may attend. If you feel that your comments have not received a fair hearing you should make your views known to the ASTM Committee on Standards, at the address shown below.

This standard is copyrighted by ASTM International, 100 Barr Harbor Drive, PO Box C700, West Conshohocken, PA 19428-2959, United States. Individual reprints (single or multiple copies) of this standard may be obtained by contacting ASTM at the above address or at 610-832-9585 (phone), 610-832-9555 (fax), or service@astm.org (e-mail); or through the ASTM website (www.astm.org). Permission rights to photocopy the standard may also be secured from the Copyright Clearance Center, 222 Rosewood Drive, Danvers, MA 01923, Tel: (978) 646-2600; <http://www.copyright.com/>