



# Standard Specification for Tops, Furniture, Marine, Steel<sup>1</sup>

This standard is issued under the fixed designation F826; the number immediately following the designation indicates the year of original adoption or, in the case of revision, the year of last revision. A number in parentheses indicates the year of last reapproval. A superscript epsilon ( $\epsilon$ ) indicates an editorial change since the last revision or reapproval.

## 1. Scope

1.1 This specification covers the construction of steel furniture tops for use where invoked by other marine furniture specifications.

1.2 This specification applies to tops for furniture case goods only such as chests of drawers, log desks with cabinets, and so forth.

1.3 The values stated in inch-pound units are to be regarded as standard. The values given in parentheses are mathematical conversions to SI units that are provided for information only and are not considered standard.

## 2. Referenced Documents

### 2.1 ASTM Standards:<sup>2</sup>

[A366/A366M Specification for Commercial Steel \(CS\) Sheet, Carbon, \(0.15 Maximum Percent\) Cold-Rolled \(Withdrawn 2000\)](#)<sup>3</sup>

[B16/B16M Specification for Free-Cutting Brass Rod, Bar and Shapes for Use in Screw Machines](#)

[B221 Specification for Aluminum and Aluminum-Alloy Extruded Bars, Rods, Wire, Profiles, and Tubes](#)

[D907 Terminology of Adhesives](#)

### 2.2 NEMA Specification:<sup>4</sup>

[ANSI/NEMA LD-3 High Pressure Decorative Laminates](#)

### 2.3 AISC Manual:<sup>5</sup>

[AISC Wire and Sheet Metal Gauges Equivalent Thickness in Decimals of an Inch, U.S. Standard Gauge \(USSG\) for Uncoated Hot and Cold Rolled Sheets](#)

### 2.4 ANSI Standard:<sup>6</sup>

[A208.1 American National Standard for Mat Formed Particle Board](#)

## 3. Terminology

### 3.1 Definitions of Terms Specific to This Standard:

3.1.1 *case goods*—furniture items having drawers, a cabinet with doors, or both.

3.1.2 *edge binder*—the strips of metal or other material applied to the edges of a top.

3.1.3 *lee rails*—extensions above the surface of furniture tops that retain items placed on top.

3.1.4 *substrate material*—the core, or structural material of the top, to which the melamine laminate is directly bonded.

3.1.5 *tops*—the horizontal surface that makes up the upper exposed surface of furniture items.

## 4. Classification

4.1 Tops shall be of the following types as required by the specifications for the item of furniture and as indicated in the ordering documents. See [Fig. 1](#), [Fig. 2](#), [Table 1](#), and [Table 2](#) for details.

4.1.1 *Type I*—Top on which the edge binder is flush with the top and the substrate material is steel.

4.1.2 *Type II*—Top on which the edge binder projects above the upper surface of the top to act as a lee rail and the substrate material is steel.

4.1.3 *Type III*—Top on which a lee rail is applied to the upper surface of the finished top, the top has a self edge securely bonded to the finished top, and the substrate material is a particle or mineral board core.

4.1.4 *Type IV*—Top is an insert panel and the edge binder is an integral part of the supporting furniture unit.

4.1.4.1 *Grade 1*—Substrate material and edge reinforcements for Types I, II, and IV Grade 1 tops shall be a minimum of 16 USSG (0.0598-in. or 1.6-mm) steel in accordance with Specification [A366/A366M](#).

4.1.4.2 *Grade 2*—Substrate material is a particle or mineral board core with a minimum density of 45 lb/ft<sup>3</sup> (722 kg/m<sup>3</sup>).

<sup>1</sup> This specification is under the jurisdiction of ASTM Committee F25 on Ships and Marine Technology and is the direct responsibility of Subcommittee F25.03 on Outfitting and Deck Machinery.

Current edition approved Jan. 1, 2017. Published January 2017. Originally approved in 1983. Last previous edition approved in 2010 as F826 – 94 (2010). DOI: 10.1520/F0826-94R17.

<sup>2</sup> For referenced ASTM standards, visit the ASTM website, [www.astm.org](http://www.astm.org), or contact ASTM Customer Service at [service@astm.org](mailto:service@astm.org). For *Annual Book of ASTM Standards* volume information, refer to the standard's Document Summary page on the ASTM website.

<sup>3</sup> The last approved version of this historical standard is referenced on [www.astm.org](http://www.astm.org).

<sup>4</sup> Available from National Electrical Manufacturers Association (NEMA), 1300 N. 17th St., Suite 900, Arlington, VA 22209, <http://www.nema.org>.

<sup>5</sup> Available from American Institute of Steel Construction (AISC), 130 E. Randolph St., Suite 2000, Chicago, IL 60601-6219, <http://www.aisc.org>.

<sup>6</sup> Available from American National Standards Institute (ANSI), 25 W. 43rd St., 4th Floor, New York, NY 10036, <http://www.ansi.org>.

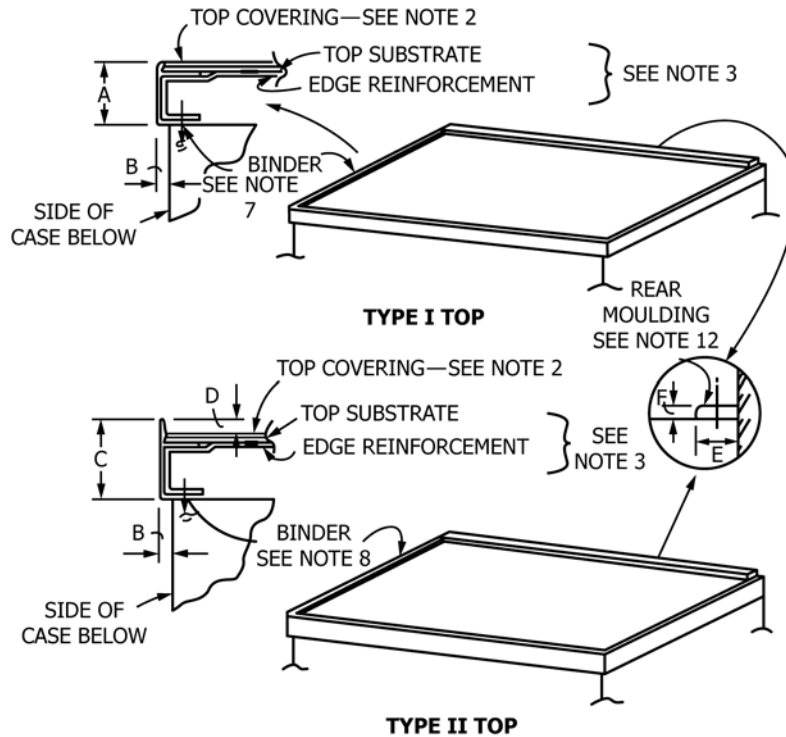

FIG. 1 Furniture Tops Types I and II

NOTE 1—For dimensions, see Table 1.

NOTE 2—Top covering for all type tops shall be high-pressure melamine laminate in accordance with ANSI/NEMA LD-3, with a maximum thickness of 1.59 mm (1/16 in.), securely bonded to upper surface of substrate material.

NOTE 3—Material of substrate and edge reinforcements for Type I, II, and IV Grade 1 tops shall be a minimum of 16 USSG (1.52-mm or 0.0598-in.) steel in accordance with Specification A366/A366M.

NOTE 4—Material of substrate for Type III tops shall be mineral board or particle board in accordance with ANSI A208.1 with a maximum thickness of 25.4 mm (1 in.).

NOTE 5—Material of substrate for Type IV Grade 2 tops shall be 13-mm (1/2-in.) thick particle board in accordance with ANSI A208.1 or 13-mm (1/2-in.) thick mineral board.

NOTE 6—For Type I, II, and IV Grade 1 tops, a stiffener shall be applied to any area of the steel substrate having an unsupported width greater than 89 mm (greater than 3 1/2 in.), see Fig. 3. Stiffener shall be 18 USSG (1.21 mm or 0.0478 in.) in accordance with Specification A366/A366M.

NOTE 7—Edge binder for Type I top shall be of Type 6063-T1 anodized aluminum extrusion in accordance with Specification B221 and installed flush with upper surface of finished top.

NOTE 8—The combination edge binder and lee rail for Type II top shall be of Type 6063-T1 anodized aluminum extrusion in accordance with Specification B221 and installed so it projects above the upper surface of top a maximum of 9.53 mm (3/8 in.) to act as a lee rail.

NOTE 9—For Type III tops, a self edge of the same material as the melamine top covering shall be securely bound to the top edge. See 6.8.2 for other details.

NOTE 10—For Type III top, a lee rail of polished and lacquered brass in accordance with Specification B16/B16M shall be applied to upper surface of finished top after application of melamine covering and shall project above the upper surface of the top a maximum of 1.35 mm (1/4 in.).

NOTE 11—Type IV top is an inserted panel, and the edge binder is an integral part of the supporting furniture unit.

NOTE 12—The rear molding for tops of Type I, II, and IV Grades 1 and 2 shall be an anodized aluminum extruded bar in accordance with Specification B221 attached to top with No. 6 oval head stainless steel machine screws.

NOTE 13—The rear molding for Type III top shall be of polished and lacquered brass in accordance with Specification B16/B16M attached to top with No. 6 oval head brass machine screws.

NOTE 14—Type III and Type IV Grade 2 tops shall have a backing sheet securely bonded to underside of particle board substrate. Backing sheet shall be a resinous similar to top covering.

NOTE 15—Type IV Grade 1 and 2 tops shall be retained in case with No. 8 hex head jack screws and lock nuts spaced 203.2 mm (8 in.) on centers.

NOTE 16—Completed top shall be securely attached to the supporting furniture unit below.

## 5. Ordering Information

5.1 Tops are included as part of the orders for items of furniture requiring tops. These orders shall include the following information:

- 5.1.1 Type.
- 5.1.2 Color or pattern of top covering material, or both.
- 5.1.3 If Type III top is ordered, whether lee rail is required.

## 6. Materials and Manufacture

6.1 For typical design, see Fig. 1 and Fig. 2.

6.2 *Sheet Metal*, shall be cold-rolled steel, commercial quality, furniture grade in accordance with Specification A366/A366M.

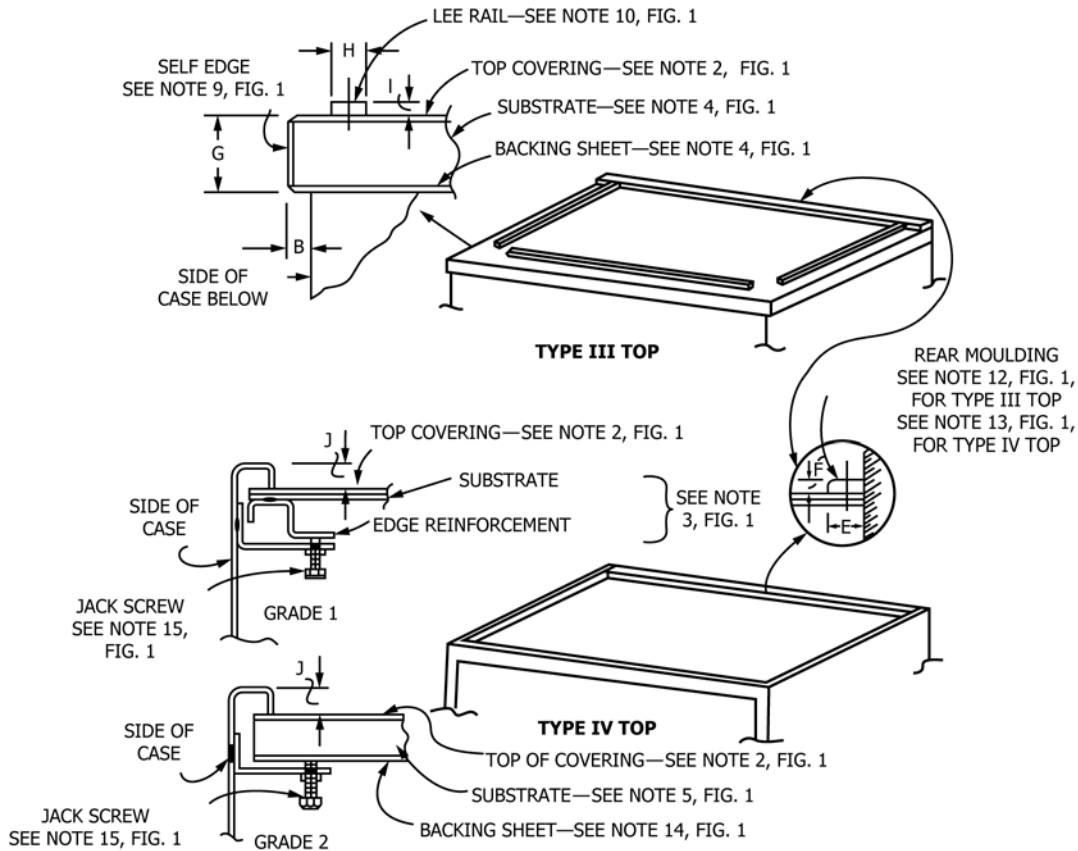

NOTE 1—For dimensions, see Table 2.  
 NOTE 2—See Notes 2 through 16 under Fig. 1.

FIG. 2 Furniture Tops Types III and IV

TABLE 1 Type I and II Top Dimensions

Designation		Dimension		Tolerances, + or -	
		in.	mm.	in.	mm.
Edge binder height	A	1¼ max	32 max	1/16	2
Top overhang (side)	B	¼ max	6 max	1/16	2
Edge binder height	C	1⅜	35	1/16	2
Lee rail height	D	1/8	3	+1/4 - 0	+6 - 0
Back molding width	E	5/8	16	1/16	2
Back molding height	F	3/16	5	1/32	1.0

TABLE 2 Type III and Type IV Top Dimensions

Designation		Dimension		Tolerances + or -	
		in.	mm.	in.	mm.
Top overhang (side)	B	¼ max	6 max	1/16	2
Back molding width	E	5/8	16	1/16	2
Back molding height	F	3/16	5	1/32	1.0
Top thickness	G	1⅜ max	29 max	1/16	2
Lee rail width	H	5/16	8	1/32	1.0
Lee rail height	I	¼	6	1/32	1.0
Lee rail height	J	3/16	5	+1/16 - 0	+2 - 0

6.3 Joining:

6.3.1 Metal components shall be joined by welding or gluing with a structural adhesive as defined in Terminology D907.

6.3.2 Joining shall be adequate to prevent racking during handling.

6.3.3 Spotwelds, shall be spaced approximately 3 in. (76 mm) on centers.

6.3.4 Visible Spotwelds, higher than the general surface of the metal, shall be ground flush.

6.3.5 Spotweld Depressions, shall be spot filled and sanded flush.

6.4 Top Covering for All Type Tops, shall be high-pressure melamine laminate in accordance with ANSI/NEMA LD-3, with a minimum thickness of 0.045 in. (1.1 mm) and a maximum thickness of 0.062 in. (1.6 mm) securely bonded to upper surface of substrate material.

6.5 Completed Top, shall be securely attached to the supporting furniture unit below.

6.6 Type I also has the following requirements:

6.6.1 Substrate, a minimum of 16 USSG (0.0598 in. or 1.50 mm) of steel in accordance with Specification A366/A366M.

6.6.2 Edge Reinforcement, shall be a minimum of 16 USSG (0.0598 in. or 1.50 mm) of steel in accordance with Specification A366/A366M.

6.6.3 For Types I, II, and IV Grade 1 tops, a stiffener shall be applied to any area of the steel substrate having an unsupported width >3½ in. (>89 mm). Stiffener shall be 18 USSG (0.0478 in. or 1.20 mm) in accordance with Specification A366/A366M. See Fig. 3 for a definition of this requirement.

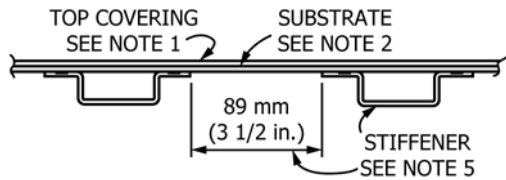

NOTE 1—See Notes 2 through 16 under Fig. 1.

**FIG. 3 Stiffener Spacing**

6.6.4 *Edge Binder*, for Type I top shall be of Type 6063-TI anodized aluminum extrusion in accordance with Specification **B221** and installed flush with the upper surface of the finished top.

6.6.5 *Back Molding*, shall be an anodized aluminum extruded bar in accordance with Specification **B221**, attached to the top with No. 6 oval head stainless steel machine screws.

6.7 Type II also has the following requirements.

6.7.1 Substrate in accordance with **6.6.1**.

6.7.2 Edge reinforcement in accordance with **6.6.2**.

6.7.3 Substrate stiffener in accordance with **6.6.3**.

6.7.4 *Combination Edge Binder and Lee Rail*, shall be of Type 6063-TI anodized aluminum-alloy extrusion in accordance with Specification **B221** and installed so it projects above the upper surface of top a minimum of ¼ in. (6.35 mm) to act as a lee rail.

6.7.5 Back molding in accordance with **6.6.5**.

6.8 Type III also has the following requirements:

6.8.1 *Substrate*, shall be particle board core in accordance with ANSI A208.1, or mineral board core, maximum thickness of 1 in. (25.4 mm).

6.8.2 *Self Edge*, of the same material as the melamine top covering shall be securely bound to the top edge. Where tops have radiused edges requiring a postforming grade of the melamine laminate, a black color may be used if a top matching color or pattern in postforming melamine laminate is not available.

6.8.3 *Lee Rail of Polished and Lacquered Brass*, in accordance with Specification **B16/B16M** shall be applied to upper surface of finished top after application of melamine covering and shall project above the upper surface of the top a maximum of ¼ in. (6 mm).

6.8.4 Types III and IV Grade 2 tops shall have a backing sheet securely bonded to the underside of particle board substrate material. The backing sheet shall be a ANSI/NEMA LD-3 Type BK30 or BK40 high-pressure back laminate.

6.9 Type IV, Grade 1 also has the following requirements:

6.9.1 Substrate in accordance with **6.6.1**.

6.9.2 Edge reinforcement in accordance with **6.6.2**.

6.9.3 Substrate stiffener in accordance with **6.6.3**.

6.9.4 The top is an inserted panel and the edge binder is an integral part of the supporting furniture unit. The edge binder, except for rear molding, is 18 USSG steel (0.0478 in. or 1.20 mm) in accordance with Specification **A366/A366M**.

6.9.5 The back molding shall be in accordance with **6.6.5**.

6.10 Type IV, Grade 2 also has the following requirements:

6.10.1 *Substrate*, shall be particle board core in accordance with ANSI A208.1 or mineral board core, ½ in. (13 mm) thick.

6.10.2 Binder in accordance with **6.9.4**.

6.10.3 Backing sheet in accordance with **6.8.4**.

6.10.4 Back molding in accordance with **6.6.5**.

6.11 Type IV Grades 1 and 2 tops shall be retained in case with No. 8 hex head jack screws and lock nuts spaced 8 in. (203 mm) on center. The completed top shall be attached securely to the supporting furniture unit below.

## 7. Performance Requirements

7.1 Tops shall be capable of supporting a load of 400 lb (181 kg) uniformly distributed over an area of 2 ft<sup>2</sup> (0.2 m<sup>2</sup>) and placed at any location on the top. Load shall remain on top for a minimum of 3 min, and there shall be no indication of permanent set after removal of load.

## 8. Dimensions

8.1 Tops shall be made to a size that suits the furniture item that supports them.

8.2 Lee rails shall not extend above the upper surface of the finished top more than ¼ in. (6 mm).

## 9. Workmanship, Finish, and Appearance

9.1 All workmanship and material shall be of specified quality in keeping with the best commercial marine practice to produce each item suitable for its intended use.

9.2 All exposed burrs, raw, or sharp edges which might be injurious to personnel shall be removed.

9.3 Depressions considered unacceptable for product's end use shall be spot filled and sanded smooth.

9.4 Plastic laminate shall be well bonded to top substrate and shall have no loose edges.

9.5 All tops shall be flat.

9.6 *Finish:*

9.6.1 All steel surfaces, unless corrosion resistant or with a corrosion-resistant plating, shall be painted so as to prevent corrosion.

9.6.2 Unless otherwise required by the furniture specification, all normally visible parts of completed unit shall have the manufacturer's standard baked-on enamel finish.

9.6.3 Color and pattern to be specified in the ordering documents.

## 10. Inspection and Certification

10.1 Inspection and certification requirements of the furniture item on which the top is installed shall govern.

## 11. Packaging and Package Marking

11.1 Each top shall be installed in its respective furniture item before shipment. Marking and packaging requirements of furniture item shall govern.

## 12. Keywords

12.1 cabinets; furniture case goods; furniture tops; log desks; marine; marine furniture; ship; steel furniture tops

*ASTM International takes no position respecting the validity of any patent rights asserted in connection with any item mentioned in this standard. Users of this standard are expressly advised that determination of the validity of any such patent rights, and the risk of infringement of such rights, are entirely their own responsibility.*

*This standard is subject to revision at any time by the responsible technical committee and must be reviewed every five years and if not revised, either reapproved or withdrawn. Your comments are invited either for revision of this standard or for additional standards and should be addressed to ASTM International Headquarters. Your comments will receive careful consideration at a meeting of the responsible technical committee, which you may attend. If you feel that your comments have not received a fair hearing you should make your views known to the ASTM Committee on Standards, at the address shown below.*

*This standard is copyrighted by ASTM International, 100 Barr Harbor Drive, PO Box C700, West Conshohocken, PA 19428-2959, United States. Individual reprints (single or multiple copies) of this standard may be obtained by contacting ASTM at the above address or at 610-832-9585 (phone), 610-832-9555 (fax), or [service@astm.org](mailto:service@astm.org) (e-mail); or through the ASTM website ([www.astm.org](http://www.astm.org)). Permission rights to photocopy the standard may also be secured from the Copyright Clearance Center, 222 Rosewood Drive, Danvers, MA 01923, Tel: (978) 646-2600; <http://www.copyright.com/>*