



# Standard Specification for Drawers, Furniture, Marine, Steel<sup>1</sup>

This standard is issued under the fixed designation F825; the number immediately following the designation indicates the year of original adoption or, in the case of revision, the year of last revision. A number in parentheses indicates the year of last reapproval. A superscript epsilon ( $\epsilon$ ) indicates an editorial change since the last revision or reapproval.

## 1. Scope

1.1 This specification covers the construction of steel furniture drawers for use where invoked by other marine furniture specifications.

1.2 This specification applies to all furniture drawers, except items requiring progressive drawers.

1.3 The values stated in inch-pound units are to be regarded as standard. The values given in parentheses are mathematical conversions to SI units that are provided for information only and are not considered standard.

## 2. Referenced Documents

### 2.1 ASTM Standards:<sup>2</sup>

A240/A240M Specification for Chromium and Chromium-Nickel Stainless Steel Plate, Sheet, and Strip for Pressure Vessels and for General Applications

A366/A366M Specification for Commercial Steel (CS) Sheet, Carbon, (0.15 Maximum Percent) Cold-Rolled (Withdrawn 2000)<sup>3</sup>

A653/A653M Specification for Steel Sheet, Zinc-Coated (Galvanized) or Zinc-Iron Alloy-Coated (Galvannealed) by the Hot-Dip Process

D907 Terminology of Adhesives

### 2.2 AISC Manual:<sup>4</sup>

AISC Wire and Sheet Metal Gauges Equivalent Thickness in Decimals of an Inch, U.S. Standard Gauge (USSG) for Uncoated Hot and Cold Rolled Sheets

## 3. Terminology

### 3.1 Definitions of Terms Specific to This Standard:

<sup>1</sup> This specification is under the jurisdiction of ASTM Committee F25 on Ships and Marine Technology and is the direct responsibility of Subcommittee F25.03 on Outfitting and Deck Machinery.

Current edition approved Jan. 1, 2017. Published January 2017. Originally approved in 1983. Last previous edition approved in 2010 as F825 – 93 (2010). DOI: 10.1520/F0825-93R17.

<sup>2</sup> For referenced ASTM standards, visit the ASTM website, [www.astm.org](http://www.astm.org), or contact ASTM Customer Service at [service@astm.org](mailto:service@astm.org). For *Annual Book of ASTM Standards* volume information, refer to the standard's Document Summary page on the ASTM website.

<sup>3</sup> The last approved version of this historical standard is referenced on [www.astm.org](http://www.astm.org).

<sup>4</sup> Available from American Institute of Steel Construction (AISC), 130 E. Randolph St., Suite 2000, Chicago, IL 60601-6219, <http://www.aisc.org>.

3.1.1 *drawers*—storage units in furniture items that have tracks on the sides to allow the drawer to slide open or closed.

3.1.2 *tracks*—the supporting assembly, attached to the sides of a drawer, that allows a drawer to slide open or closed.

3.1.3 *drawer tracks*—that portion of the track assembly that is attached to drawer sides.

3.1.4 *case track*—that portion of the track assembly that is attached to side of supporting furniture (case) item.

## 4. Ordering Information

4.1 Drawers are included as part of the orders for items of furniture requiring drawers. These orders shall include the following:

### 4.1.1 Paint:

4.1.1.1 *Color*—Drawers shall be painted to match the furniture item in which they are installed.

4.1.1.2 Manufacturer's standard baked enamel will be furnished unless otherwise required and indicated by the purchaser.

4.1.2 Locks, if required, shall be installed where noted in the ordering documents.

## 5. Materials and Manufacture

5.1 For typical design, see Fig. 1.

### 5.2 Joining:

5.2.1 *Metal Components of Drawers*, shall be joined by welding or gluing with a structural adhesive as defined in Terminology D907.

5.2.2 Joining shall be adequate to prevent racking during handling.

5.2.3 *Spotwelds*, shall be spaced approximately 3 in. (76 mm) on centers.

5.2.4 *Visible Spotwelds*, on the exterior face of drawer front, higher than the general surface of the metal, shall be ground flush.

5.2.5 *Visible Spotweld Depressions*, on the exterior face of drawer front, shall be spot filled and sanded flush.

5.3 *Drawer Front*, body and back a minimum of 20 USSG (0.0359 in. or 0.90 mm) in accordance with Specification A366/A366M.

5.4 *Drawer Locks*, if required, shall be disk tumbler cam locks having 90° rotation with a screw-on or spun-on cap

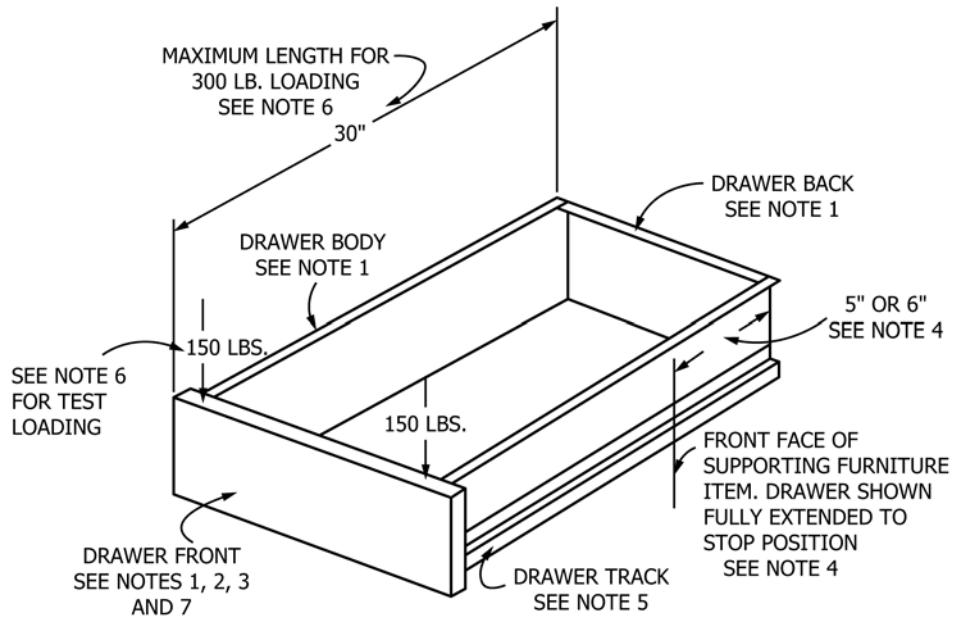

NOTE 1—Drawer front, body, and back shall be a minimum of 20 USSG (0.0359 in. or 0.91 mm) in accordance with Specification [A366/A366M](#).

NOTE 2—Drawers shall be furnished with a means for pulling drawers open.

NOTE 3—Drawers shall incorporate a positive latch to prevent drawers from opening in heavy seas. See [5.6](#) and Note 7 below.

NOTE 4—Drawers shall be equipped with a means for stopping the drawer in the fully extended position. In this fully extended position, the drawer shall project into the supporting furniture unit no more than 6 in. (152.4 mm) for drawers 20 in. (508 mm) long and over and 5 in. (127 mm) for drawers less than 20 in. (508 mm).

NOTE 5—Drawer and case track shall be zinc-coated steel in accordance with Specification [A653/A653M](#) and a minimum of 18 USSG (0.0478 in. or 1.22 mm). They shall be equipped with anti-friction devices, such as nylon buttons, on horizontal bearing surfaces to minimize friction.

NOTE 6—See [6.1](#) for drawer test-loading requirements.

NOTE 7—See [6.2](#) for drawer tilt test requirements.

**FIG. 1 Furniture Drawers**

attachment. Cylinders shall be die-cast zinc with exposed surfaces finished in satin nickel-plated US-15 finish.

5.5 *Drawers*, shall be equipped with a means for stopping the drawer at fully extended position. In this fully extended position, the drawer shall project into the supporting furniture unit no more than 6 in. (152 mm) for drawers 20 in. (508 mm) long and over and 5 in. (127 mm) for drawers less than 20 in. (508 mm).

5.6 All drawers shall incorporate a latch or other positive means to prevent drawers opening in heavy seas. Spring, bullet, magnetic, or bayonet-type catches will not be permitted. Furniture drawers shall not open when the furniture unit in which drawer is installed is tilted a maximum of 30° from the vertical with a drawer load of 30 lb (14 kg).

5.7 All drawers shall be furnished with a means for pulling drawers open.

5.8 *Drawer and Case Tracks:*

5.8.1 Each drawer shall have a pair of drawer tracks with one drawer track on each of its sides. The supporting furniture (case) shall incorporate case tracks on each side to support drawer track.

5.8.2 Drawer and case tracks shall be zinc-coated steel in accordance with Specification [A653/A653M](#), a minimum of 18 USSG (0.0478 in. or 1 mm).

5.8.3 Drawer and case tracks shall be equipped with anti-friction devices, such as nylon buttons, on all horizontal bearing surfaces to minimize friction.

**6. Performance Requirements**

6.1 *Load Requirement:*

6.1.1 Unless otherwise specified, all drawers 30 in. and below (762 mm and below) in length shall safely support a load of 300 lb (136 kg). The load requirement does not apply to drawers with lengths over 30 in. (over 762 mm).

6.1.2 These loads shall be applied to the front edge of the drawer, with the drawer fully extended to the drawer stop position. Load shall remain on drawer for 3 min.

6.1.3 This test shall not adversely affect the operation of the drawer, and no indication of permanent set shall exist after removal of load. Brinelling, or crushing of replaceable nylon buttons in track assembly, shall not constitute failure under this test.

6.2 *Tilt Test:*

6.2.1 Drawers shall be checked against sliding open in a tilted attitude by randomly placing 30 lb (14 kg) of books in the drawer. The item of furniture shall then be tilted 30° from the vertical and maintained in this position for 3 min. During this time, the drawer must remain closed.



## 7. Dimensions

7.1 Drawers shall be made to a size that suits the furniture item that supports them.

## 8. Workmanship, Finish, and Appearance

8.1 All workmanship and material shall be of specified quality in keeping with the best commercial marine practice to produce each item suitable for its intended use.

8.2 All exposed burrs, raw, or sharp edges that might be injurious to personnel shall be removed.

8.3 Depressions considered unacceptable for the product's end use shall be spot filled and sanded smooth.

### 8.4 Finish:

8.4.1 All steel surfaces, unless corrosion resistant or with a corrosive-resistant plating, shall be painted so as to prevent corrosion.

8.4.2 Unless otherwise required by the furniture specification, all normally visible parts of the completed unit shall have the manufacturer's standard baked-on enamel finish.

## 9. Inspection and Certification

9.1 Inspection and certification requirements of the furniture item in which the drawer or drawers is installed shall govern.

## 10. Packaging and Package Marking

10.1 Each drawer shall be installed in its respective furniture item before shipment. Marking and packaging requirements of the furniture item shall govern.

## 11. Keywords

11.1 drawers; marine furniture; steel furniture drawers

*ASTM International takes no position respecting the validity of any patent rights asserted in connection with any item mentioned in this standard. Users of this standard are expressly advised that determination of the validity of any such patent rights, and the risk of infringement of such rights, are entirely their own responsibility.*

*This standard is subject to revision at any time by the responsible technical committee and must be reviewed every five years and if not revised, either reapproved or withdrawn. Your comments are invited either for revision of this standard or for additional standards and should be addressed to ASTM International Headquarters. Your comments will receive careful consideration at a meeting of the responsible technical committee, which you may attend. If you feel that your comments have not received a fair hearing you should make your views known to the ASTM Committee on Standards, at the address shown below.*

*This standard is copyrighted by ASTM International, 100 Barr Harbor Drive, PO Box C700, West Conshohocken, PA 19428-2959, United States. Individual reprints (single or multiple copies) of this standard may be obtained by contacting ASTM at the above address or at 610-832-9585 (phone), 610-832-9555 (fax), or service@astm.org (e-mail); or through the ASTM website (www.astm.org). Permission rights to photocopy the standard may also be secured from the Copyright Clearance Center, 222 Rosewood Drive, Danvers, MA 01923, Tel: (978) 646-2600; http://www.copyright.com/*