



Standard Specification for Type PS-46 and Type PS-115 Poly(Vinyl Chloride) (PVC) Plastic Gravity Flow Sewer Pipe and Fittings¹

This standard is issued under the fixed designation F 789; the number immediately following the designation indicates the year of original adoption or, in the case of revision, the year of last revision. A number in parentheses indicates the year of last reapproval. A superscript epsilon (ϵ) indicates an editorial change since the last revision or reapproval.

1. Scope

1.1 This specification covers requirements and test methods for materials, dimensions, workmanship, flattening resistance, impact resistance, pipe stiffness, extrusion quality, joining systems, and a form of marking for Type PS-46 and Type PS-115 poly(vinyl chloride) (PVC) plastic, gravity flow sewer pipe having a minimum pipe stiffness of 46 psi (320 kPa) and 115 psi (790 kPa), respectively, and fittings.

1.2 Pipe and fittings produced to this specification shall be installed in accordance with Practice D 2321.

1.3 The values stated in inch-pound units are to be regarded as the standard. The values given in parentheses are provided for information purposes only.

1.4 The following precautionary caveat pertains only to the test method portion, Section 8, of this specification: *This standard does not purport to address all of the safety concerns, if any, associated with its use. It is the responsibility of the user of this standard to establish appropriate safety and health practices and determine the applicability of regulatory limitations prior to use.*

2. Referenced Documents

2.1 ASTM Standards:

- D 618 Practice for Conditioning Plastics and Electrical Insulating Materials for Testing²
- D 1784 Specification for Rigid Poly(Vinyl Chloride) (PVC) Compounds and Chlorinated Poly(Vinyl Chloride) (CPVC) Compounds^{3,4}
- D 2122 Test Method for Determining Dimensions of Thermoplastic Pipe and Fittings⁴
- D 2152 Test Method for Degree of Fusion of Extruded Poly(Vinyl Chloride) (PVC) Pipe and Molded Fittings by Acetone Immersion⁴
- D 2321 Practice for Underground Installation of Thermoplastic Pipe for Sewers and Other Gravity-Flow Applications⁴

- D 2412 Test Method for Determination of External Loading Characteristics of Plastic Pipe by Parallel-Plate Loading⁴
- D 2444 Test Method for Impact Resistance of Thermoplastic Pipe and Fittings by Means of a Tup (Falling Weight)⁴
- D 2564 Specification for Solvent Cements for Poly(Vinyl Chloride) (PVC) Plastic Piping Systems⁴
- D 2855 Practice for Making Solvent-Cemented Joints with Poly(Vinyl Chloride) (PVC) Pipe and Fittings⁴
- D 3212 Specification for Joints for Drain and Sewer Plastic Pipes Using Flexible Elastomeric Seals⁴
- F 402 Practice for Safe Handling of Solvent Cements, Primers, and Cleaners Used for Joining Thermoplastic Pipe and Fittings⁴
- F 412 Terminology Relating to Plastic Piping Systems⁴
- F 477 Specification for Elastomeric Seals (Gaskets) for Joining Plastic Pipe⁴
- 2.2 Federal Standard:
Fed. Std. No. 123 Marking for Shipment (Civil Agencies)⁵
- 2.3 Military Standard:
MIL-STD-129 Marking for Shipment and Storage⁵

3. Terminology

3.1 Definitions:

3.1.1 *General*—Definitions used in the specification are in accordance with Terminology F 412 unless otherwise indicated. The abbreviation for poly(vinyl chloride) is PVC.

3.1.2 The terms PS-46 and PS-115 are not abbreviations but rather arbitrary designations for products having minimum pipe stiffnesses, at 5 % deflection, of 46 psi (320 kPa) and 115 psi (790 kPa) when tested in accordance with Test Method D 2412.

4. Significance and Use

4.1 The requirements of this specification are intended to provide pipe and fittings suitable for nonpressure drainage of sewage and surface water.

NOTE 1—Industrial waste disposal lines should be installed only with specific approval of the cognizant code authority since chemicals not commonly found in drains and sewers and temperatures in excess of 140°F (60°C) may be encountered.

¹ This specification is under the jurisdiction of ASTM Committee F-17 on Plastic Piping Systems and is the direct responsibility of Subcommittee F17.62 on Sewer. Current edition approved Oct. 10, 1995. Published December 1995. Originally published as F 789 – 82. Last previous edition F 789 – 95.

² *Annual Book of ASTM Standards*, Vol 08.01.

³ *Annual Book of ASTM Standards*, Vol 08.02.

⁴ *Annual Book of ASTM Standards*, Vol 08.04.

⁵ Available from Standardization Documents Order Desk, Bldg. 4 Section D, 700 Robbins Ave., Philadelphia, PA 19111-5094, Attn: NPODS.

5. Materials

5.1 *Basic Materials*—The pipe shall be made of PVC having a minimum cell classification of 12164-B as defined in Specification D 1784 with a minimum tensile strength of 4000 psi (28 MPa). The fittings shall be made of PVC plastic having a cell classification of 12454-C or 13343-C as defined in Specification D 1784. Compounds that have different cell classifications because one or more properties are superior to those of the specified compound are also acceptable.

5.2 *Rework Material*—Clean rework material generated from the manufacturer's own pipe or fittings production may be used by the same manufacturer provided that the pipe or fittings produced meet all the requirements of this specification.

5.3 *Gaskets*—Elastomeric seals (gaskets) shall comply with the requirements of Specification F 477.

5.4 *Lubricant*—The lubricant used for assembly shall have no detrimental effect on the gasket or on the pipe or fittings.

5.5 *Solvent Cement*—The PVC solvent cement used in joining of pipe and fittings for solvent cement joints shall comply with the requirements of Specification D 2564.

6. Joining Systems

6.1 *Gasketed Joints*—The joint shall be designed so that when assembled, the gasket inside the bell will be compressed radially on the pipe spigot to form a watertight seal.

6.1.1 The joint shall be designed to avoid displacement of the gasket when installed in accordance with the manufacturer's recommendations.

6.1.2 The assembly of joints shall be in accordance with the pipe manufacturer's recommendations.

6.2 *Solvent Cement Joints*—In the solvent cement joint, the pipe spigot wedges into the tapered socket and the surfaces fuse together. The tapered socket may be a portion of a molded fitting or it may be a belled end of a pipe section.

6.2.1 The assembly of joints shall be in accordance with Practice D 2855 and taking cognizance of Practice F 402.

7. Requirements

7.1 *Workmanship*—The pipe and fittings shall be homogeneous throughout and free of visible cracks, holes, foreign inclusions, or other injurious defects. The pipe shall be uniform in color, opacity, density, and other physical properties.

7.2 *Pipe Dimensions:*

7.2.1 *Diameter*—The average outside diameter shall meet the requirements given in Table 1 when measured in accordance with 8.4.1.

7.2.2 *Wall Thickness*—Pipe wall thickness shall meet the requirements given in Table 1 when measured in accordance with 8.4.2. In the case of belled pipe for solvent or gasket joining and fittings fabricated from pipe sections, the thickness of the wall in the bell shall be considered satisfactory if it was formed from pipe meeting the above requirements.

NOTE 2—Fabricated fittings with solvent-cemented components should be made in accordance with Practice D 2855 and taking cognizance of Practice F 402. Currently there are only fabricated fittings for 18-in. pipe.

7.3 *Socket Dimensions for Solvent Cemented Joints and Fittings:*

7.3.1 *Socket Diameter*—The inside diameter of the tapered socket shall comply with the dimensions listed in Table 2 when determined in accordance with 8.5.1.

7.3.2 *Socket Depth*—The socket depth shall comply with the dimensions listed in Table 2 when measured in accordance with 8.5.2.

7.4 *Molded Fittings Dimensions:*

7.4.1 *Wall Thickness of Molded Fittings*—The wall thickness of the waterway and socket or bell of molded fittings shall be no less than the minimum thickness listed for that nominal size in Table 2. For reducing fittings or those with small inlets, the minimum wall thickness of each inlet shall be no less than the minimum wall thickness for that nominal size in Table 2. The thickness shall be determined in accordance with Test Method D 2122 and 8.5.3.

7.4.2 *Laying Length*—The laying length of fittings shall meet the requirements of Table 3, Table 4, Table 5, Table 6, and Table 7.

7.4.3 *Other Dimensions*—Certain other fitting dimensions are given in Table 8, Table 9, Table 10, and Table 11.

7.5 *Pipe Flattening*—There shall be no evidence of splitting, cracking, or breaking when pipe is tested in accordance with 8.6.

7.6 *Pipe Impact Strength*—The impact strength of the pipe at the time of manufacture shall not be less than the values given in Table 12 when tested in accordance with 8.7.

NOTE 3—This test is intended only for use as a quality control test, not as a simulated service test. As aged impact data is developed, the applicable aged impact values will be included to reflect long-term performance needs.

7.7 *Pipe Stiffness*—Pipe stiffness values for the pipe shall equal or exceed 46 psi (320 kPa) or 115 psi (790 kPa) when tested in accordance with 8.8.

7.8 *Solvent Cement*—The cement shall meet the requirements of Specification D 2564.

7.9 *Elastomeric Seals (Gaskets).*

7.9.1 All gaskets shall meet the requirements of Specification F 477.

7.10 *Joint Tightness:*

7.10.1 *Elastomeric Seal (Gasketed) Joints*—Joints made with pipe and fittings having elastomeric seals show no sign of leakage when tested in accordance with Specification D 3212. All surfaces of the joint, upon which the gasket bears, shall be smooth and free of imperfections, ridges, fractures, or cracks that could adversely affect the seal.

7.10.2 *Solvent Cement Joints*—Joints made with solvent cement joining shall show no sign of leakage when tested in accordance with 8.9.2.

7.11 *Acetone Immersion*—The pipe shall not show flaking or disintegration when tested in accordance with 8.10.

NOTE 4—This test is intended only for use as a quality control test and is not for use as a simulated service test.

TABLE 1 Pipe Dimensions for Type PS-46 and PS-115

<i>Type PS-46 Pipe Dimensions</i>																
Nominal Pipe Size in.	Outside Diameter				Wall Thickness											
	Average Outside Diameter		Tolerance on Average Outside Diameter		T-1 ^A				T-2 ^B				T-3 ^C			
	in.	(mm)	in.	(mm)	Estimated Average ^D		Min		Estimated Average ^D		Min		Estimated Average ^D		Min	
					(in.)	(mm)	(in.)	(mm)	(in.)	(mm)	(in.)	(mm)	(in.)	(mm)	in.	(mm)
4	4.215	(107.1)	±0.009	(±0.229)	0.114	(2.89)	0.107	(2.72)	0.111	(2.82)	0.104	(2.64)	0.108	(2.74)	0.102	(2.59)
6	6.275	(159.4)	±0.011	(±0.280)	0.170	(4.32)	0.160	(4.06)	0.165	(4.19)	0.155	(3.94)	0.161	(4.09)	0.151	(3.84)
8	8.400	(213.4)	±0.012	(±0.305)	0.227	(5.77)	0.213	(5.41)	0.221	(5.61)	0.208	(5.28)	0.216	(5.49)	0.203	(5.16)
10	10.500	(266.7)	±0.015	(±0.381)	0.284	(7.21)	0.267	(6.78)	0.276	(7.01)	0.259	(6.58)	0.270	(6.86)	0.254	(6.45)
12	12.500	(317.5)	±0.018	(±0.457)	0.338	(8.59)	0.318	(8.08)	0.329	(8.36)	0.309	(7.85)	0.321	(8.15)	0.302	(7.67)
15	15.300	(388.6)	±0.023	(±0.584)	0.414	(10.52)	0.389	(9.88)	0.403	(10.24)	0.379	(9.63)	0.393	(9.98)	0.369	(9.37)
18	18.700	(475.0)	±0.028	(±0.710)	0.507	(12.88)	0.477	(12.16)	0.494	(12.55)	0.464	(11.79)	0.482	(12.24)	0.452	(11.48)

<i>Type PS-115 Pipe Dimensions</i>																
Nominal Pipe Size in.	Outside Diameter				Wall Thickness											
	Average Outside Diameter		Tolerance on Average Outside Diameter		T-1 ^A				T-2 ^B				T-3 ^C			
	in.	(mm)	in.	(mm)	Estimated Average ^D		Min		Estimated Average ^D		Min		Estimated Average ^D		Min	
					(in.)	(mm)	(in.)	(mm)	(in.)	(mm)	(in.)	(mm)	(in.)	(mm)	in.	(mm)
4	4.215	(107.1)	±0.009	(±0.229)	0.152	(3.86)	0.143	(3.63)	0.148	(3.76)	0.139	(3.53)	0.144	(3.66)	0.135	(3.43)
6	6.275	(159.4)	±0.011	(±0.280)	0.226	(5.74)	0.214	(5.44)	0.220	(5.59)	0.207	(5.26)	0.215	(5.46)	0.202	(5.13)
8	8.400	(213.4)	±0.012	(±0.305)	0.302	(7.67)	0.284	(7.21)	0.294	(7.47)	0.276	(7.01)	0.287	(7.29)	0.270	(6.86)
10	10.500	(266.7)	±0.015	(±0.381)	0.378	(9.60)	0.355	(9.02)	0.363	(9.22)	0.341	(8.66)	0.359	(9.12)	0.337	(8.56)
12	12.500	(317.5)	±0.018	(±0.457)	0.450	(11.43)	0.423	(10.74)	0.438	(11.13)	0.414	(10.46)	0.428	(10.87)	0.402	(10.21)
15	15.300	(388.6)	±0.023	(±0.584)	0.548	(13.92)	0.515	(13.08)	0.536	(13.61)	0.504	(12.80)	0.523	(13.28)	0.492	(12.50)
18	18.700	(475.0)	±0.028	(±0.710)	0.673	(17.09)	0.633	(16.08)	0.655	(16.54)	0.616	(15.65)	0.640	(16.26)	0.602	(15.29)

^A T-1, made from material with 440 000 to 480 000 psi (3.0 to 3.3 GPa) modulus.

^B T-2, made from material with 480 000 to 520 000 psi (3.3 to 3.6 GPa) modulus.

^C T-3, made from material with 520 000 to 560 000 psi (3.6 to 3.9 GPa) modulus.

^D Average wall shall be adjusted to give a minimum pipe stiffness. The minimum pipe stiffness shall be determined by testing the pipe. Meeting the minimum wall is not assurance that the minimum stiffness has been met.

8. Test Methods

8.1 Conditioning:

8.1.1 *Referee Testing*—When conditioning is required for referee tests, condition the specimens in accordance with Procedure A of Practice D 618 at 73.4 ± 3.6°F (23 ± 2°C) and 50 ± 5 % relative humidity for not less than 40 h prior to test. Conduct tests under the same conditions of temperature and humidity, unless otherwise specified.

8.1.2 *Quality Control Tests*—For quality control tests, condition the specimens for a minimum of 4 h in air or 1 h in water at 73.4 ± 3.6°F (23 ± 2°C). Test the specimens at 73.4 ± 3.6°F without regard to relative humidity.

8.2 *Test Conditions*—Conduct tests in the Standard Laboratory Atmosphere at 73.4 ± 3.6°F (23 ± 2°C) and 50 ± 5 % relative humidity, unless otherwise specified in the test methods or in this specification. In cases of disagreement, the tolerances shall be ±1.8°F (±1°C) and ±2 % relative humidity.

8.3 *Sampling*—The selection of pipe samples shall be as agreed upon between the purchaser and seller. In case of no prior agreement, samples selected by the testing laboratory shall be deemed adequate.

8.4 Pipe Dimensions:

8.4.1 *Pipe Diameters*—Measure the average outside diameter of the pipe in accordance with Test Method D 2122 using a circumferential wrap tape accurate to ±0.001 in. (±0.02 mm).

8.4.2 *Wall Thickness*—Measure the wall thickness in accordance with Test Method D 2122. Make sufficient readings, a minimum of 8, to ensure that the minimum thickness has been determined. Use a ball anvil or a cylindrical anvil tubing micrometer accurate to ±0.001 in. (±0.02 mm).

8.5 Molded Fittings Dimensions:

8.5.1 *Socket Diameters*—Measure the inside diameters of the sockets at the entrance and bottom in accordance with Test Method D 2122. Calculate the average inside diameters at the entrance and at bottom of the socket as the arithmetic mean of all of the diameters measured at each cross section.

8.5.2 *Socket Depth*—Measure the fittings socket depth using a good commercial quality scale calibrated in 1/32-in. (1-mm) increments in accordance with Test Method D 2122.

8.5.3 *Wall Thickness*—Measure the wall thickness in accordance with Test Method D 2122. Make sufficient readings, a minimum of 8, to ensure that the minimum thickness has been determined. Use a ball anvil or a cylindrical anvil tubing micrometer accurate to ±0.001 in. (±0.02 mm).

TABLE 2 Solvent Cemented Socket Dimensions and Molded Fittings Wall Thickness

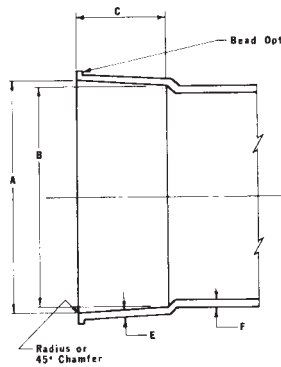

Nom-inal Size, in.	Socket Entrance, A in.	Socket Bottom, B in.	Socket Depth, C in.	Molded Fittings, Min Wall Thickness ^A , in. E and F
4	4.235 ±0.009	4.210 ±0.009	1.750	0.120
6	6.305 ±0.011	6.270 ±0.011	3.000	0.180
8	8.424 ±0.012	8.388 ±0.012	4.000	0.240
10	10.530 ±0.015	10.485 ±0.015	5.000	0.300
12	12.536 ±0.018	12.482 ±0.018	6.000	0.360
15	15.346 ±0.023	15.277 ±0.023	7.500	0.437

^A *Fitting Wall Thickness*—The wall thickness is a minimum value except that a ±10 % variation resulting from core shift is allowable. In such a case, the average of two opposite wall thicknesses shall equal or exceed the value shown in the table.

8.6 *Pipe Flattening*—Flatten three pipe specimens each 6-in. (152-mm) long between parallel plates in a press until the distance between plates is 40 % of the outside diameter of the pipe. The rate of loading shall be uniform and such that the flattening is completed within 2 to 5 min. The specimen shall pass if no splitting, cracking, or breaking is observed under normal light with the unaided eye.

8.7 *Impact Resistance*—Determine the impact resistance of the pipe in accordance with Test Method D 2444, using a 20-lb (10-kg) Tup A and Flat-Plate Holder B. Test six specimens each 6-in. (152-mm) long at the impact levels given in Table 12. All shall pass. If one fails, test another six specimens; 11 passes out of 12 tested is acceptable.

8.8 *Pipe Stiffness*—Determine the pipe stiffness at 5 % deflection using Test Method D 2412. Test three specimens, each 6-in. (152-mm) long, and determine the average pipe stiffness in accordance with Test Method D 2412.

NOTE 5—The 5 % deflection criterion that was arbitrarily selected for testing convenience, should not be considered as a limitation with respect to in-use deflection. The engineer is responsible for establishing the acceptable deflection limit.

8.9 *Joint Tightness:*

8.9.1 *Elastomeric Seal (Gasketed) Joints*—Joints made with pipe and fittings having elastomeric seals shall show no sign of leakage when tested in accordance with Specification D 3212.

8.9.2 *Solvent Cement Joints*—Join two pieces of pipe by means of a fitting or socket in accordance with Practice D 2855, using solvent cement as described in 7.8. Allow the joined unit to stand 24 h at room temperature. Subject the unit to an internal water pressure of 25 psi (170 kPa) for 1 h, and examine the pipe fittings and joints for leakage.

8.10 *Acetone Immersion*—This test shall be conducted in accordance with Test Method D 2152. This procedure is used for determining the degree of fusion of extruded PVC plastic pipe as indicated by reaction to immersion in anhydrous acetone. It is applicable only for distinguishing between unfused and properly fused PVC.

9. Retest and Rejection

9.1 If the results of any test(s) do not meet the requirements of this specification, the test(s) may be conducted again in accordance with an agreement between the purchaser and the seller. There shall be no agreement to lower the minimum requirement of the specification by such means as omitting tests that are a part of the specification, substituting or modifying a test method, or by changing the specification limits. In retesting, the product requirements of this specification shall be met, and the test methods designated in the specification shall be followed. If, upon retest, failure occurs, the quantity of product represented by the test(s) does not meet the requirement of this specification.

10. Inspection

10.1 *Inspection by Purchaser*—Inspection shall be made as agreed upon between the purchaser and the seller as a part of the purchase contract.

10.1.1 *Inspection Notification*—If purchaser inspection is specified, the manufacturer shall notify the purchaser, in advance, of the date, time, and place of testing the pipe in order that the purchaser may be represented at the test.

10.1.2 *Inspector Access*—The inspector shall have free access to those parts of the manufacturer’s plant that are involved in inspection and product testing work performed under the specification. The manufacturer shall provide the inspector facilities for determining whether the pipe meets the requirements of this specification.

11. Certification

11.1 When agreed upon in writing by the purchaser and the producer, a certification shall be made the basis of acceptance of material. This shall consist of a copy of the manufacturer’s test report or a statement by the producer that the material has been sampled, tested, and inspected in accordance with the provisions of this specification. Each certification, so furnished, shall be signed by an authorized agent of the seller or manufacturer.

TABLE 3 Laying Lengths of Long Bend Fittings (min)

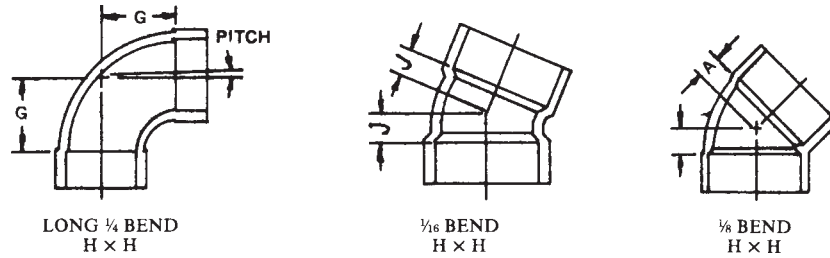

Size	G_2	J	A
4	$3\frac{1}{16}$	$\frac{1}{2}$	$\frac{7}{8}$
6	$5\frac{3}{16}$	$\frac{3}{4}$	$1\frac{3}{8}$
8	$5\frac{1}{4}$	$1\frac{1}{16}$	$1\frac{5}{16}$
10	$5\frac{7}{8}$	$1\frac{5}{16}$	$2\frac{3}{16}$
12	$6\frac{3}{16}$	$1\frac{9}{16}$	$2\frac{13}{16}$
15	$8\frac{1}{4}$	$1\frac{5}{16}$	$3\frac{1}{16}$

TABLE 4 Laying Lengths of 45° Saddle Wye and Saddle Tee (min)

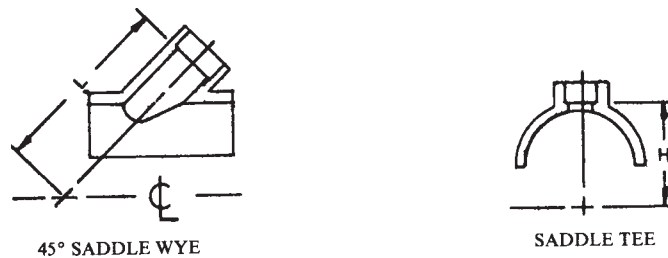

Size	L	H
6 by 4	$6\frac{3}{4}$	$3\frac{3}{16}$
8 by 4	$8\frac{1}{4}$	$4\frac{1}{4}$
8 by 6	$9\frac{5}{16}$	$4\frac{1}{4}$
10 by 4	$9\frac{3}{4}$	$5\frac{5}{16}$
10 by 6	$10\frac{7}{8}$	$5\frac{5}{16}$
12 by 4	$11\frac{5}{16}$	$6\frac{5}{16}$
12 by 6	$12\frac{3}{8}$	$6\frac{5}{16}$
15 by 4	$13\frac{7}{16}$	$17\frac{13}{16}$
15 by 6	$14\frac{7}{16}$	8

12. Marking

12.1 *Pipe Marking*—Pipe in compliance with this specification shall be clearly marked as follows at intervals of 5 ft (1.5 m), or less:

12.1.1 Manufacturer’s name or trademark or trade name or logo,

12.1.2 Nominal pipe size,

12.1.3 The PVC materials minimum cell classification as listed in Section 5, for example, 12164-B,

12.1.4 Modulus indicator, for example T-1, T-2, or T-3,

12.1.5 The legend “PS-46 PVC Gravity Sewer Pipe” or “PS-115 PVC Gravity Sewer Pipe,”

12.1.6 This designation, ASTM F 789, and

12.1.7 Manufacturer’s code to include day, month, year, shift plant, and extruder of manufacturer.

12.2 *Fittings Markings*—Fittings in compliance with this specification shall be clearly marked as follows:

12.2.1 Manufacturer’s name or trademark,

12.2.2 Nominal size,

12.2.3 The material designation “PVC”, and

12.2.4 This designation, ASTM .

12.3 The markings shall be applied to the pipe and fittings in such a manner that they remain legible after inspection and installation have been completed.

TABLE 5 Laying Lengths of 45° Wye (min)

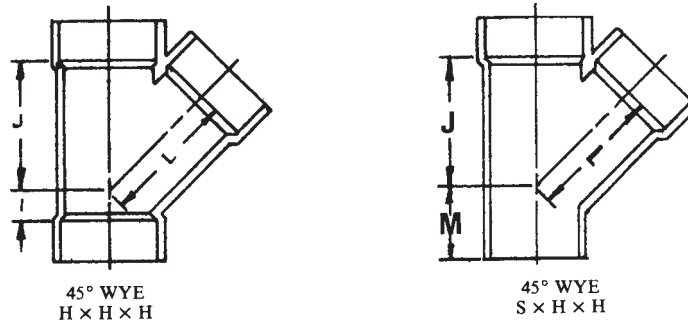

Size	<i>l</i>	<i>J</i>	<i>L</i>	<i>M</i>
4	7/8	5 1/8	5 1/8	2 23/32
6	1 5/16	7 1/2	7 1 1/16	4 5/16
8	2	10	10 3/8	6
10	2 1/4	12 1/2	12 5/16	7 1/4
12	2 1 1/16	14 15/16	15 3/8	8 1 1/16
15	3 5/16	18 3/4	19 1/16	10 13/16

TABLE 6 Laying Lengths of Short Bends and Crosses (min)

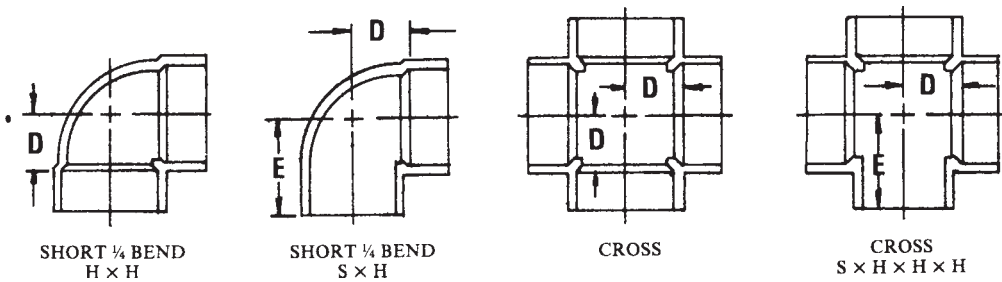

Size	<i>D</i>	<i>E</i>
4	2 5/32	4 1/16
6	3 3/16	6 15/16
8	4 9/32	8 1 7/32
10	5 5/16	10 7/16
12	6 3/8	12 1/2
15	7 15/16	15 9/16

13. Packaging

13.1 All pipe and couplings and fittings shall be packaged for standard commercial shipment, unless otherwise specified.

14. Quality Assurance

14.1 When the product is marked with this designation, F 789, the manufacturer affirms that the product was manufac-

tured, inspected, sampled, and tested in accordance with this specification and has been found to meet the requirements of this specification.

15. Keywords

15.1 PVC; sewer pipe

TABLE 7 Laying Lengths of Tees, Reducing Tees, and 45° Reducing Wye (min)

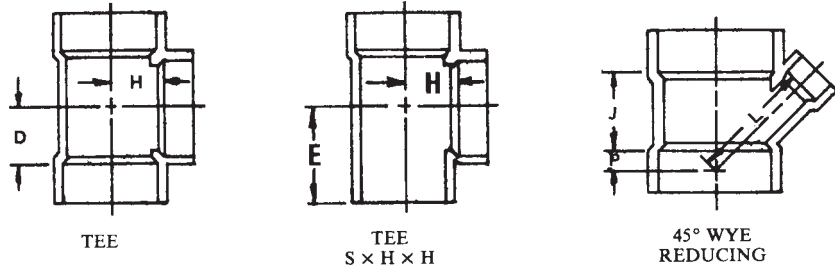

Size	D	E	H	J	L	P
4	2 ⁵ / ₃₂	4 ¹ / ₁₆	2 ⁵ / ₃₂			
6	3 ⁹ / ₁₆	6 ⁹ / ₁₆	3 ⁹ / ₁₆			
6 by 4	2 ³ / ₃₂	5 ¹ / ₄	3 ⁷ / ₃₂	6 ³ / ₃₂	6 ² / ₃₂	1 ¹ / ₃₂
8	4 ⁹ / ₃₂	8 ¹⁷ / ₃₂	4 ⁹ / ₃₂			
8 by 4	2 ³ / ₁₆	6 ³ / ₈	4 ¹ / ₄	7 ⁹ / ₃₂	8 ³ / ₁₆	2 ⁹ / ₃₂
8 by 6	3 ³ / ₁₆	7 ³ / ₈	4 ⁹ / ₃₂	9 ⁷ / ₃₂	9 ⁷ / ₃₂	1 ³ / ₃₂
10	5 ⁹ / ₁₆	10 ⁷ / ₁₆	5 ⁹ / ₁₆			
10 by 4	2 ¹ / ₄	7 ¹ / ₂	5 ⁵ / ₁₆	8 ³ / ₁₆	9 ⁷ / ₈	11 ¹³ / ₁₆
10 by 6	3 ⁷ / ₃₂	8 ¹ / ₂	5 ¹¹ / ₃₂	10 ⁹ / ₁₆	10 ⁷ / ₈	1 ¹ / ₃₂
10 by 8	4 ⁷ / ₃₂	9 ¹ / ₂	5 ⁷ / ₁₆	12	11 ¹⁵ / ₁₆	1 ⁵ / ₁₆
12	6 ³ / ₈	12 ¹ / ₂	6 ³ / ₈			
12 by 4	2 ¹ / ₄	8 ¹ / ₂	6 ¹¹ / ₃₂	9 ¹ / ₄	11 ¹ / ₄	-2 ¹³ / ₁₆
12 by 6	3 ⁹ / ₃₂	9 ¹ / ₂	6 ³ / ₈	10 ⁵ / ₈	12 ⁵ / ₁₆	-1 ¹¹ / ₃₂
12 by 8	4 ⁹ / ₃₂	10 ¹ / ₂	6 ⁷ / ₁₆	12 ⁹ / ₃₂	13 ³ / ₈	0
12 by 10	5 ⁹ / ₃₂	11 ¹ / ₂	6 ⁷ / ₁₆	15 ¹ / ₈	14 ⁷ / ₁₆	1 ¹ / ₂
15	7 ¹⁵ / ₁₆	15 ⁹ / ₁₆	7 ¹⁵ / ₁₆			
15 by 4	2 ⁹ / ₁₆	10 ³ / ₁₆	7 ⁷ / ₈	10 ⁷ / ₈	13 ¹⁵ / ₃₂	-4 ⁵ / ₁₆
15 by 6	3 ¹ / ₂	11 ³ / ₈	7 ²⁵ / ₃₂	12 ⁷ / ₁₆	14 ³ / ₄	-2 ¹⁵ / ₁₆
15 by 8	4 ⁷ / ₁₆	12 ⁵ / ₁₆	7 ⁷ / ₈	15 ¹ / ₈	15 ¹⁹ / ₃₂	1 ³ / ₈
15 by 10	5 ¹ / ₂	13 ³ / ₈	7 ²⁷ / ₃₂	15 ⁹ / ₃₂	16 ²⁵ / ₃₂	0
15 by 12	6 ¹⁵ / ₃₂	14 ³ / ₈	7 ¹⁵ / ₁₆	17 ⁵ / ₈	17 ⁵ / ₁₆	1 ³ / ₈

TABLE 8 Dimensions of Fitting Cleanout Adapter, Cap, and Plug

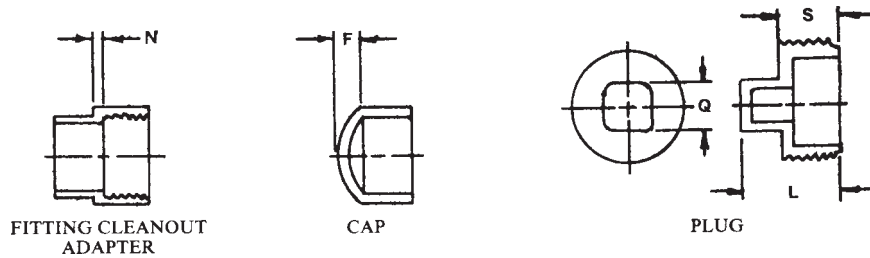

Size	N	F	L	Q	S
4	1 ¹ / ₈	9 ¹ / ₆₄	1 ⁷ / ₈	2	7 ¹ / ₈
6	7 ¹ / ₃₂	3 ¹ / ₆₄	2	2 ³ / ₈	

TABLE 9 Coupling Stop Dimensions



Coupling

Size	N
4	1/8
6	3/16

TABLE 10 Dimensions of Adaptors

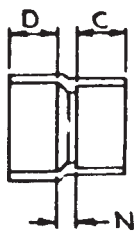

DWV to Sewer

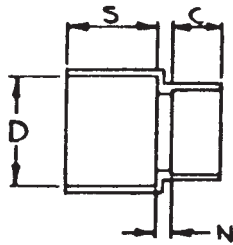

Cast Iron Spigot to PVC Sewer

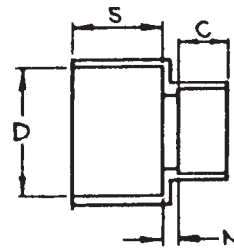

Clay Spigot to PVC Sewer

Type	Size	C	D	N	S
DWV	4 by 4	1 3/4	1 3/4	1/4	...
Cast iron	4 by 4	1 3/4	41 1/16	1/4	27 7/8
Clay	4 by 4	1 3/4	6 1/8	3/16	3

TABLE 11 Dimensions of Reducer Bushing

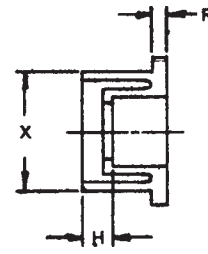
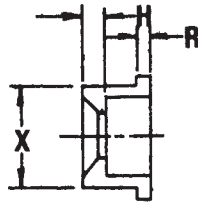
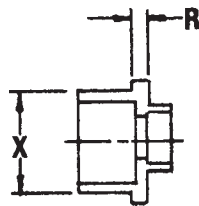

REDUCER BUSHING

Size	H	R	X
6 by 4	1 1/2	5/32	6.275
8 by 4	2 3/8	0.200	8.400
8 by 6	1	0.200	8.400

TABLE 12 Minimum Impact Strength at 73°F (23°C)

Pipe Size, in.	Impact Strength, ft-lbf (J)
4	150 (203)
6	210 (284)
8	210 (284)
10	220 (299)
12	220 (299)
15	220 (299)
18	220 (299)

SUPPLEMENTARY REQUIREMENTS

GOVERNMENT/MILITARY PROCUREMENT

These requirements apply *only* to Federal/Military procurement, not domestic sales or transfers.

S1. Responsibility for Inspection—Unless otherwise specified in the contract or purchase order, the producer is responsible for the performance of all inspection and test requirements specified herein. The producer may use his own or other suitable facilities for the performance of the inspection and test requirements specified herein, unless disapproved by the purchaser. The purchaser shall have the right to perform any of the inspections and tests set forth in this specification where such inspections are deemed necessary to ensure that material conforms to prescribed requirements.

NOTE S1—In U.S. Federal contracts, the contractor is responsible for inspection.

S2. Packaging and Marking for U.S. Government Procurement:

S2.1 Packaging—Unless otherwise specified in the contract, the material shall be packaged in accordance with the supplier's standard practice in a manner ensuring arrival at destination in satisfactory condition and which will be acceptable to the carrier at lowest rates. Containers and packing shall comply with Uniform Freight Classification rules.

S2.2 Marking—Marking for shipment shall be in accordance with Fed. Std. No. 123 for civil agencies and MIL-STD-129 for military agencies.

NOTE S2—The inclusion of the U.S. Government procurement requirements should not be construed as an indication that the U.S. Government endorses the products described in this document.

ASTM International takes no position respecting the validity of any patent rights asserted in connection with any item mentioned in this standard. Users of this standard are expressly advised that determination of the validity of any such patent rights, and the risk of infringement of such rights, are entirely their own responsibility.

This standard is subject to revision at any time by the responsible technical committee and must be reviewed every five years and if not revised, either reapproved or withdrawn. Your comments are invited either for revision of this standard or for additional standards and should be addressed to ASTM International Headquarters. Your comments will receive careful consideration at a meeting of the responsible technical committee, which you may attend. If you feel that your comments have not received a fair hearing you should make your views known to the ASTM Committee on Standards, at the address shown below.

This standard is copyrighted by ASTM International, 100 Barr Harbor Drive, PO Box C700, West Conshohocken, PA 19428-2959, United States. Individual reprints (single or multiple copies) of this standard may be obtained by contacting ASTM at the above address or at 610-832-9585 (phone), 610-832-9555 (fax), or service@astm.org (e-mail); or through the ASTM website (www.astm.org).