



# Standard Specification for Surface Discontinuities of Bolts, Screws, and Studs, Inch and Metric Series<sup>1</sup>

This standard is issued under the fixed designation F788; the number immediately following the designation indicates the year of original adoption or, in the case of revision, the year of last revision. A number in parentheses indicates the year of last reapproval. A superscript epsilon ( $\epsilon$ ) indicates an editorial change since the last revision or reapproval.

*This standard has been approved for use by agencies of the U.S. Department of Defense.*

## 1. Scope\*

1.1 This specification establishes allowable limits for the various types of surface discontinuities that may occur during the manufacture and processing of bolts, screws, and studs, including heat-treated machine screws, tapping screws, and sems (the washers of screw-washer assemblies are excluded). This specification covers metric series products with nominal diameters of 4 mm and larger and with specified minimum tensile strengths of 420 MPa and higher; and inch series products with nominal diameters of No. 5 (0.1250 in.) and larger and with specified minimum tensile strengths of 60 000 psi and higher.

1.2 When the engineering requirements of the application necessitate control of surface discontinuities on bolts, screws, or studs, the purchaser shall specify conformance to ASTM Specification F788, in the original inquiry and purchase order.

1.2.1 When the engineering requirements of the application necessitate that surface discontinuities on bolts, screws, and studs be controlled within limits closer than those specified in this specification, the purchaser shall specify the applicable limits in the original inquiry and purchase order.

1.3 The allowable limits established in this specification for metric bolts, screws, and studs with nominal diameters from 4 to 24 mm inclusive, are essentially identical with requirements given in ISO 6157/I. There are no ISO standards for surface discontinuities on any inch-series products.

1.4 The values stated in either SI units or inch-pound units are to be regarded separately as standard. The values stated in each system may not be exact equivalents; therefore, each system shall be used independently of the other. Combining values from the two systems may result in non-conformance with the standard.

<sup>1</sup> This specification is under the jurisdiction of ASTM Committee F16 on Fasteners and is the direct responsibility of Subcommittee F16.93 on Quality Assurance Provisions for Fasteners.

Current edition approved April 1, 2013. Published April 2013. Originally approved in 1982. Last previous edition approved in 2012 as F788 – 12. DOI: 10.1520/F0788-13.

## 2. Referenced Documents

2.1 *ASTM Standards:*<sup>2</sup>

- E340 Test Method for Macroetching Metals and Alloys
- F1470 Practice for Fastener Sampling for Specified Mechanical Properties and Performance Inspection
- F1789 Terminology for F16 Mechanical Fasteners

2.2 *ISO Standard:*<sup>3</sup>

- ISO 6157/I Fasteners, Surface Discontinuities on Bolts, Screws and Studs

## 3. Ordering Information

3.1 Orders for bolts, screws, and studs requiring discontinuity control shall include the following:

- 3.1.1 ASTM designation and date of issue of this specification.
- 3.1.2 Special requirements, for example, closer discontinuity limits (1.2.1) and inspection sampling plan (6.2).

## 4. Types of Surface Discontinuities (see Terminology F1789 for definitions not provided)

4.1 *Crack*

4.1.1 *Quench Cracks*—Typical quench cracks are shown in Fig. 1. Limits are specified in 5.2.

4.1.2 *Forging Cracks*—Typical forging cracks are shown in Fig. 2. Limits are specified in 5.3.

4.2 *Burst*—Typical bursts are shown in Fig. 3. Limits are specified in 5.4.

4.2.1 *Shear Burst*—A shear burst is an open break in the metal located at approximately a 45° angle to the product axis. Shear bursts occur most frequently at the periphery of products having flanged or circular heads. Shear bursts may also occur on the sides of hex-head products. Typical shear bursts are shown in Fig. 3. Limits are specified in 5.4.

<sup>2</sup> For referenced ASTM standards, visit the ASTM website, www.astm.org, or contact ASTM Customer Service at service@astm.org. For *Annual Book of ASTM Standards* volume information, refer to the standard's Document Summary page on the ASTM website.

<sup>3</sup> Available from American National Standards Institute (ANSI), 25 W. 43rd St., 4th Floor, New York, NY 10036, http://www.ansi.org.

\*A Summary of Changes section appears at the end of this standard

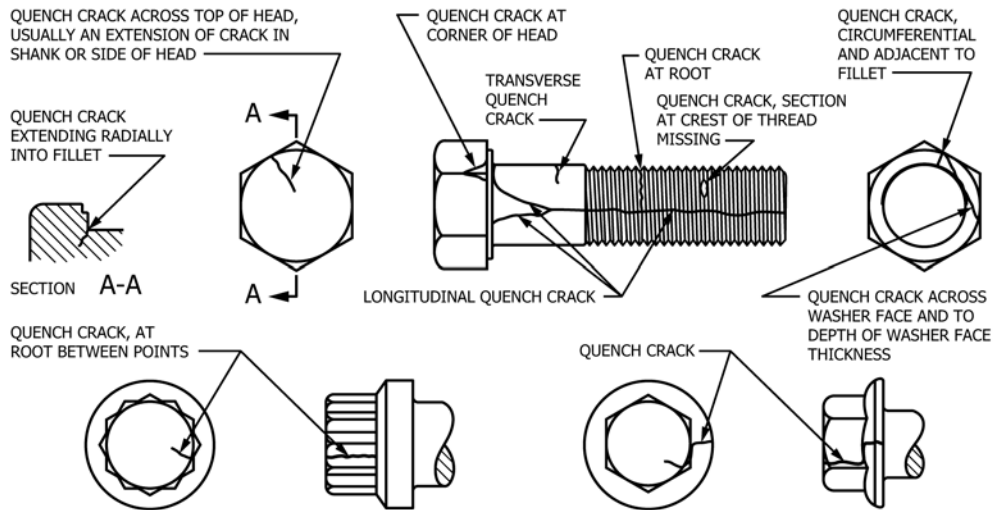

FIG. 1 Typical Quench Cracks

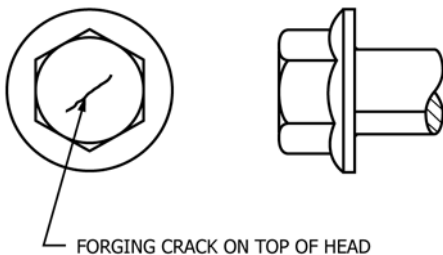

FIG. 2 Typical Forging Cracks

4.3 *Seam*—Typical seams are shown in Fig. 4. Limits are specified in 5.5.

4.4 *Fold*—Typical folds are shown in Fig. 5 a, b, and c. Limits are specified in 5.6.

4.5 *Thread Lap*—Limits are specified in Supplementary Requirement S.1.1.

4.6 *Void*—A void is a shallow pocket or hollow on the surface of a bolt or screw due to nonfilling of metal during forging. Voids are produced by marks or impressions of chips (shear burrs) or by rust formation on the raw material. They are not planished during forging. Typical voids are shown in Fig. 6. Limits are specified in 5.7.

4.7 *Tool Marks*—Tool marks are longitudinal or circumferential grooves of shallow depth produced by the movement of manufacturing tools over the surface of the bolt or screw. Typical tool marks are shown in Fig. 7. Limits are specified in 5.8.

4.8 *Gouge and Nick*—an indentation on the surface of a fastener produced by impact with another fastener, or from processing equipment during manufacture, handling or transport.

## 5. Allowable Limits

5.1 *Letter Definitions*—Throughout the following requirements,  $D$  designates the nominal size (basic major diameter of thread) of bolts, screws, and studs, except for products with shoulders, in which case  $D$  designates the largest

shoulder diameter; and  $D_c$  designates flange diameter (specified maximum) or head diameter (specified maximum) of circular head products. For metric series products,  $D$  and  $D_c$  are in millimetres; for inch-series products,  $D$  and  $D_c$  are in inches.

5.2 *Quench Cracks*—Quench cracks of any depth, any length, or in any location are not permitted.

5.3 *Forging Cracks*—Forging cracks on the top of the head of bolts and screws are permitted, provided that (a) no crack shall have a length exceeding  $1.0 D$ , and (b) no crack shall have a width or depth exceeding  $0.04 D$ . See Note 1.

NOTE 1—Forging cracks within the limits of this specification may be unsightly, but do not affect the mechanical properties or functional requirements of the bolt.

5.4 *Bursts and Shear Bursts* (see Note 2):

5.4.1 For hex-head bolts and screws, bursts and shear bursts are permitted, provided that: (1) no burst or shear burst in the flats extends into the crown (chamfer) circle on the top of the head or into the underhead bearing circle, (2) no burst or shear burst located at the intersection of two wrenching flats reduces the width across corners below its specified minimum, and (3) no burst or shear burst has a width or depth greater than  $.06D$  but not to exceed .062 in. (1.6 mm).

5.4.2 For flange bolts and screws and products with circular heads, bursts and shear bursts at the periphery of the flange or head are permitted, provided that: (1) not more than one burst or shear burst has a width greater than  $0.04 D_c$ , and (2) the width of the one burst or shear burst that exceeds a width of  $0.04 D_c$  does not have a width greater than  $0.08 D_c$ .

5.4.3 For indented head bolts and screws, bursts and shear bursts in the raised periphery of the indented head are permitted, provided that: (1) no burst or shear burst has a width greater than  $0.06 D$ , and (2) no burst or shear burst has a depth extending below the indented portion.

NOTE 2—Bursts and shear bursts within the limits of this specification may be unsightly, but do not affect the mechanical properties or functional requirements of the bolt.

5.5 *Seams*:

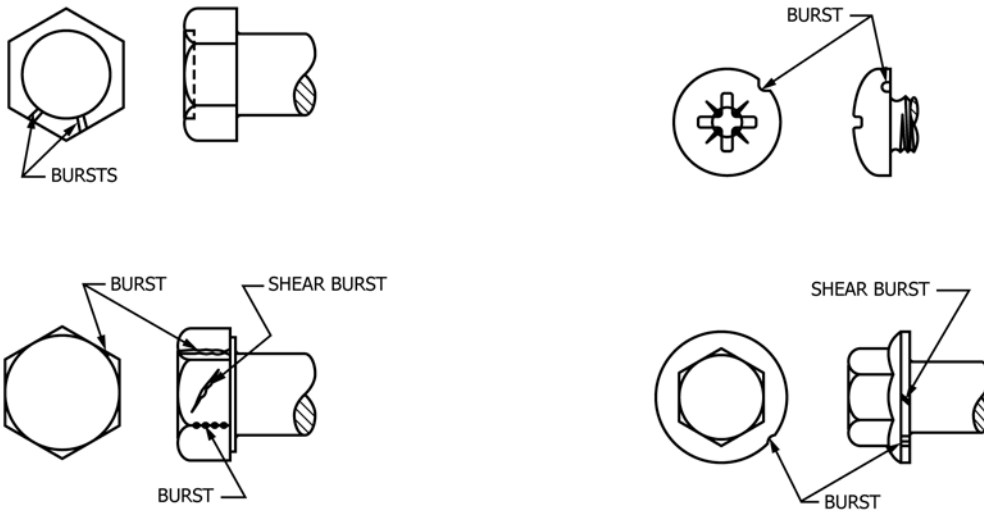

FIG. 3 Typical Bursts and Shear Bursts

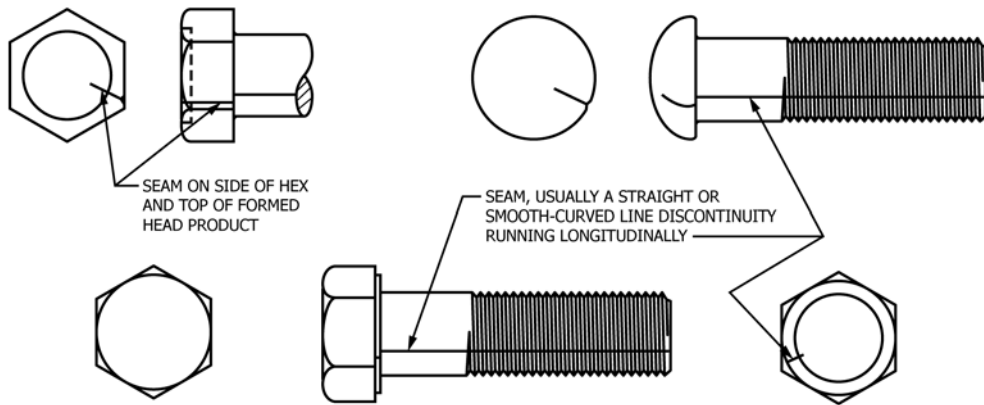

FIG. 4 Typical Seams

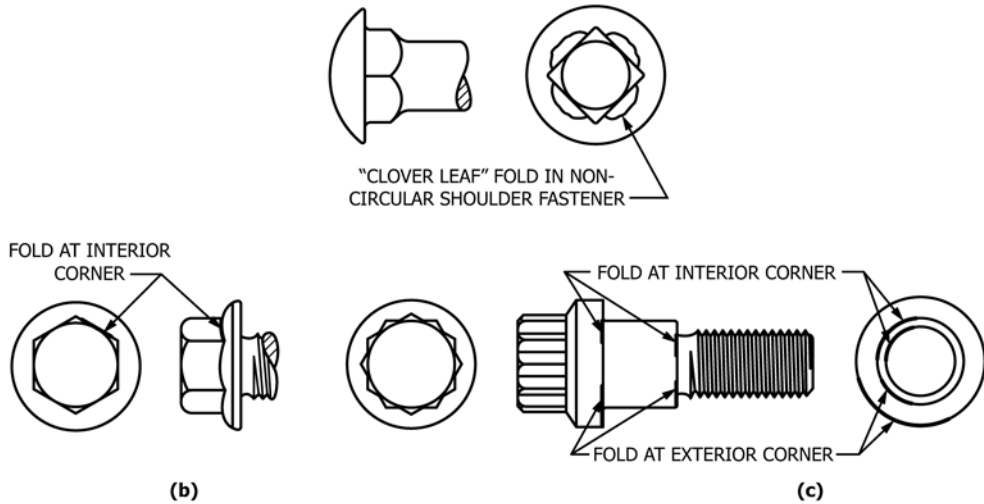
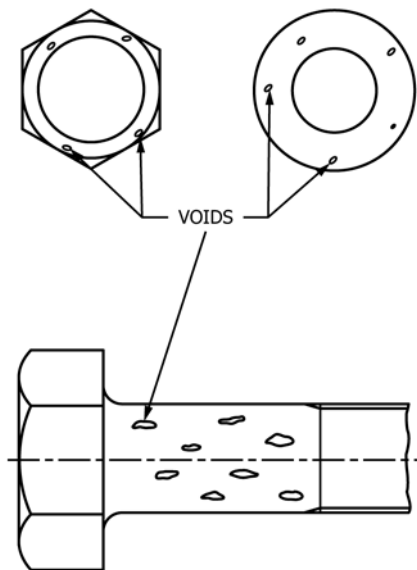

FIG. 5 Typical Folds

5.5.1 Seams in the shanks of bolts, screws, and studs are permitted provided that no seam has a depth greater than 0.03 *D*.

5.5.2 Seams extending into the heads and flanges of bolts and screws are permitted, provided that they do not open beyond the limits specified for bursts and shear bursts in 5.4.



**FIG. 6 Typical Voids**

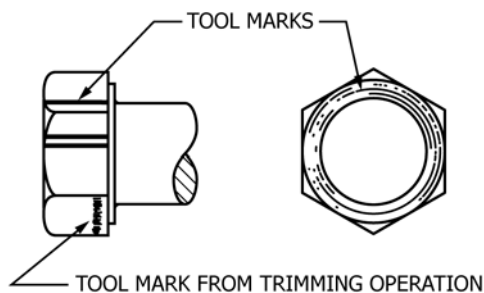

**FIG. 7 Typical Tool Marks**

#### 5.6 Folds:

5.6.1 Folds located at interior corners that are at or below the underhead bearing surface, for example, at the junction of head to shank, are not permitted, except for cloverleaf folds occurring at the intersection of non-circular shoulders with head bearing face (see Fig. 5a).

5.6.2 Folds located at interior corners that are above the underhead bearing surface, for example, at the junction of the hex head with the top of flange of flange bolts and screws, are permitted (see Fig. 5 b).

5.6.3 Folds located at exterior corners are permitted (see Fig. 5c).

#### 5.7 Voids:

5.7.1 Voids on the surfaces of bolts, screws, and studs are permitted, provided that: (1) depth of voids does not exceed 0.25 mm or 0.010 in. or 0.02  $D$ , whichever is greater, and (2) the combined area of all voids on the underhead bearing surface of bolts and screws does not exceed 10 % of the specified minimum bearing surface area.

5.7.2 The method for determining the area of voids on the bearing surface shall be as agreed upon between the purchaser and the producer.

#### 5.8 Tool Marks:

5.8.1 Tool marks on the underhead bearing surface are permitted, provided the surface roughness measurement does

not exceed 3.2  $\mu\text{m}$  or 125  $\mu\text{in.}$ , determined as the arithmetic average deviation from the mean surface.

5.8.2 Tool marks on other surfaces of the product are permitted.

5.9 *Nicks and Gouges*—Nicks, gouges, dents, and scrapes are permitted, provided that the functionality of the product is not impaired.

## 6. Inspection and Evaluation

6.1 Bolts, screws, and studs shall be inspected for surface discontinuities in accordance with the procedure in 6.2, 6.3, and 6.4.

6.2 The purchaser shall specify in the original inquiry and purchase order the inspection sampling requirements that the producer must satisfy to demonstrate the acceptability of bolts, screws, and studs with respect to surface discontinuities.

6.3 In the absence of purchaser instructions (6.2), inspection and evaluation shall be in accordance with 6.5.

6.4 For referee purposes, unless other procedures have been specified by the purchaser (6.2), inspection and evaluation shall be in accordance with 6.5.

### 6.5 Inspection Procedure:

#### 6.5.1 Visual Inspection:

6.5.1.1 A random sample shall be taken from the lot in accordance with Guide F1470 and examined visually (magnetic particle or fluid penetrant are recommended) for the presence of quench cracks, forging cracks, bursts, shear bursts, seams, folds, voids, tool marks, and nicks and gouges. Visual inspection can include the use of devices that provide up to, and including, 10-power magnification.

6.5.1.2 If, during this inspection, any products are found with quench cracks in any location or with folds at interior corners that are at or below the underhead bearing surface, the lot may be rejected by the purchaser.

6.5.1.3 If, during this inspection, any products are found with any other surface discontinuity, each discontinuity shall be measured, and if any is found that exceeds the allowable dimensional limits for that discontinuity as specified in Section 5, the lot may be rejected by the purchaser.

6.5.1.4 When a GO ring gage will not assemble the full thread length of an externally threaded fastener when torque is applied by hand, whether due to surface discontinuities or coating buildup, or both, the following procedure shall be used to determine thread acceptability. Using an appropriately calibrated torque measuring device and an appropriately calibrated GO ring gage (class 3A for inch and 6h for metric fasteners) either hold the ring gage or the bolt stationary and rotate the other the full length of the bolt thread. Record the maximum torque observed. Nicks, gouges, or accumulation of coating materials shall not interfere with hand assembly of initial thread engagement or impair product function. No lubricant shall be added to the bolt or gage for purposes of conducting the test. The indicated maximum torque value shall not exceed those in Table 1 that are derived the indicated formula.

TABLE 1 Bolt and Screw Thread Discontinuity Acceptance Criteria

Inch Fasteners				[Metric Fasteners]		
Size	Nominal Diameter (d) in.	Allowable Torque		Size	Nominal Diameter (d) mm	Allowable Torque Nm
		in. lb	ft. lb			
#10	0.190	1.0		M5	5	0.1
#12	0.216	1.5		M6	6	0.2
1/4	0.250	2.5		M8	8	0.5
5/16	0.312	4.5		M10	10	1.0
3/8	0.375	7.5		M12	12	1.7
7/16	0.438		1.0	M14	14	2.7
1/2	0.500		1.5	M16	16	4.1
9/16	0.563		2.2	M18	18	5.8
5/8	0.625		3.0	M20	20	8.0
3/4	0.750		5.1	M22	22	10.6
7/8	0.875		8.1	M24	24	13.8
1	1.000		12.1	M30	30	27.0
1 1/8	1.125		17.2	M33	33	36.0
1 1/4	1.250		23.6	M36	36	46.6
1 3/8	1.375		31.4	...	...	...
1 1/2	1.500		40.8	...	...	...
Formula		$T = 145d^3$	$T = 145d^3/12$	Formula		$T = 0.001d^3$

7. Keywords

7.1 bolts; crack; discontinuities (surface); fold; screw (machine, sems, tapping); seam; studs; thread lap; void

SUPPLEMENTARY REQUIREMENTS

One or more of the following supplementary requirements shall apply only when specified by the purchaser in the inquiry and order. Supplementary Requirements shall in no way negate any requirement of the specification itself.

S1. Assemblies Subject to Severe Dynamic Stresses

S1.1 Laps in Screw Threads:

S1.1.1 Laps of any depth and any length which originate below (or originating above and extending below) a point located at a distance equal to or less than 20 % of the thread height, measured from the minor diameter, are not permitted. See 4.5 and the Fig. S1.1 and Fig. S1.2.

S1.1.2 Surface discontinuities of threads caused by the thread rolling process, as in Fig. S1.2, shall be excluded from these requirements provided the discontinuities do not exceed the depth of 0.5 % × nominal diameter and are essentially parallel to the adjacent thread contour and are not directed toward the screw or bolt axis.

S1.2 Thread Lap Inspection:

S1.2.1 Visual Inspection—A random sample shall be selected from the lot in accordance with F1470. The sample selected shall be surface etched in a 50 % solution of HCl and H<sub>2</sub>O at approximately 180°F (no more than 5 min of etch time should be employed as excessive etching may remove shallow thread laps). After etch, the samples shall be examined under a 10× magnification for the presence of laps.

S1.2.2 Microscopic Examination—If laps are present, one of the samples shall be sectioned longitudinally on the center line of the bolt/screw and on a plane passing through the point at which any lap extends closest to the minor diameter of the thread. The section shall be etched for microscopic examination in accordance with Test Method E340. Acceptance shall be based on the requirements of S1.1.

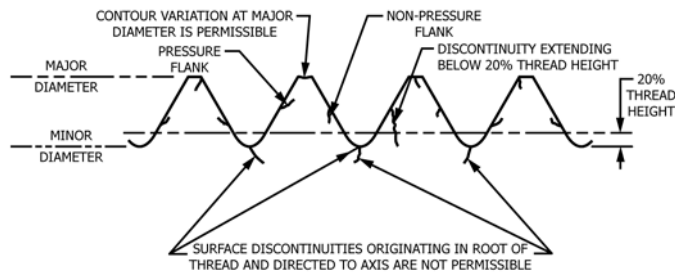
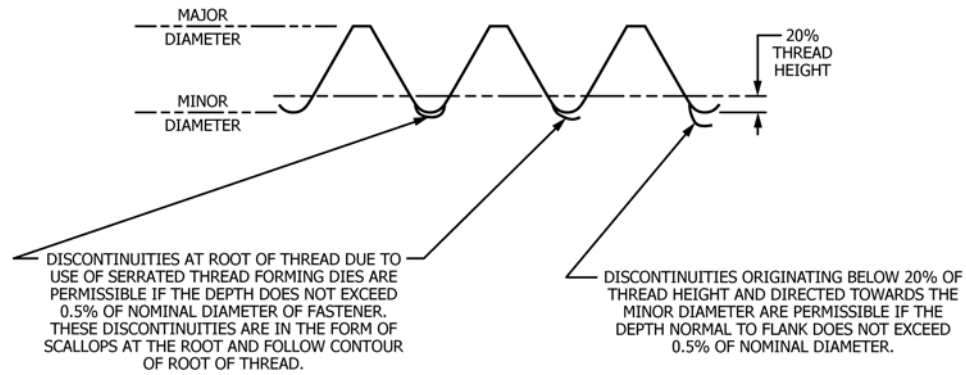

FIG. S1.1 Typical Thread Laps





NOTE 1—Laps which originate below (or originate above and extend below) 20 % thread height are not permissible discontinuities except as shown in Fig. S1.2.

FIG. S1.2 Typical Starting Serrations

### SUMMARY OF CHANGES

Committee F16 has identified the location of selected changes to this standard since the last issue F788 – 12 that may impact the use of this standard. (Approved April 1, 2013)

- (1) Added coatings consideration to 6.5.1.4.
- (2) Revised units in Table 1.

Committee F16 has identified the location of selected changes to this standard since the last issue F788/F788M-08 that may impact the use of this standard.

- (1) F788M was removed from the designation.

*ASTM International takes no position respecting the validity of any patent rights asserted in connection with any item mentioned in this standard. Users of this standard are expressly advised that determination of the validity of any such patent rights, and the risk of infringement of such rights, are entirely their own responsibility.*

*This standard is subject to revision at any time by the responsible technical committee and must be reviewed every five years and if not revised, either reapproved or withdrawn. Your comments are invited either for revision of this standard or for additional standards and should be addressed to ASTM International Headquarters. Your comments will receive careful consideration at a meeting of the responsible technical committee, which you may attend. If you feel that your comments have not received a fair hearing you should make your views known to the ASTM Committee on Standards, at the address shown below.*

*This standard is copyrighted by ASTM International, 100 Barr Harbor Drive, PO Box C700, West Conshohocken, PA 19428-2959, United States. Individual reprints (single or multiple copies) of this standard may be obtained by contacting ASTM at the above address or at 610-832-9585 (phone), 610-832-9555 (fax), or service@astm.org (e-mail); or through the ASTM website (www.astm.org). Permission rights to photocopy the standard may also be secured from the ASTM website (www.astm.org/COPYRIGHT/).*