



# Standard Practice for Design and Installation of Rigid Pipe Hangers<sup>1</sup>

This standard is issued under the fixed designation F708; the number immediately following the designation indicates the year of original adoption or, in the case of revision, the year of last revision. A number in parentheses indicates the year of last reapproval. A superscript epsilon ( $\epsilon$ ) indicates an editorial change since the last revision or reapproval.

*This standard has been approved for use by agencies of the U.S. Department of Defense.*

## 1. Scope

1.1 This practice covers acceptable methods of fabricating and installing rigid pipe hangers used to support shipboard piping systems with temperatures of 650°F (343°C) or less.

1.2 This practice provides guidance for the design of hanger caps, straps and standoffs, selection of hanger and hanger liner materials, hanger bolting, and hanger spacing.

1.3 Other hanger designs may be used provided they result in an adequately supported vibration-free piping system and are compatible with the intended system service and temperature limitations.

1.4 The values stated in inch-pound units are to be regarded as the standard. The values given in parentheses are for information only.

1.5 *This standard does not purport to address all of the safety concerns, if any, associated with its use. It is the responsibility of the user of this standard to establish appro-*

*priate safety and health practices and determine the applicability of regulatory limitations prior to use.*

## 2. Referenced Documents

2.1 *ASTM Standards:*<sup>2</sup>

[A307 Specification for Carbon Steel Bolts, Studs, and Threaded Rod 60 000 PSI Tensile Strength](#)

## 3. Terminology

3.1 *Definitions:*

3.1.1 *liner*—the material used to isolate a pipe from its hanger.

3.1.2 *riding bar*—a protective strip of material installed between the pipe and the hanger where frequent linear movement of the pipe is expected.

3.1.3 *rigid pipe hanger*—a device that transfers the load imposed by the piping, insulation, and system medium to the supporting structure.

3.1.4 *standoff*—the rigid member that connects the hanger strap, saddle, or band to the supporting structure. A standoff is

---

<sup>1</sup> This practice is under the jurisdiction of ASTM Committee F25 on Ships and Marine Technology and is the direct responsibility of Subcommittee F25.11 on Machinery and Piping Systems.

Current edition approved Aug. 1, 2014. Published September 2014. Originally approved in 1981. Last previous edition approved in 2008 as F708 – 92 (2008). DOI: 10.1520/F0708-92R14.

---

<sup>2</sup> For referenced ASTM standards, visit the ASTM website, [www.astm.org](http://www.astm.org), or contact ASTM Customer Service at [service@astm.org](mailto:service@astm.org). For *Annual Book of ASTM Standards* volume information, refer to the standard's Document Summary page on the ASTM website.

usually made up of one or more pieces of flat bar, pipe, angle bar, or flanged plate to suit a specific location.

**4. List of Pipe Hanger Styles**

4.1 This practice incorporates 26 pipe hanger assemblies as shown on Figs. 1-12(c) as follows:

Hanger	Fig. No.
Split cap hanger (single leg standoff)	1(a)
Split cap hanger (dual leg standoff)	1(b)
Split cap hanger (chair type)	1(c)
Strap hanger	2(a)
Strap hanger (assembled for clearance with rider bar)	2(b)
Strap hanger (assembled for clearance with TFE-fluorocarbon strip)	2(c)
Welded hanger (flat bar U-type)	3(a)
Welded hanger (round bar U-type)	3(b)
Welded hanger (square bar U-type)	3(b)
U-bolt hanger	4(a)
U-bolt hanger (assembled for clearance with rider bar)	4(b)
U-bolt hanger (assembled for clearance with TFE-fluorocarbon strip)	4(c)
Welded hanger (single leg standoff welded direct to pipe)	5(a)
Welded hanger (dual leg standoff welded direct to pipe)	5(b)
“J” band type hanger (insulated pipe)	6(a)
“J” band type hanger (bare pipe)	6(b)
Nelson hanger <sup>3,4</sup>	7
Clamp hanger assembled with mounting channel	8
Poly-block twin clamp hanger (assembled with welding plate) <sup>5,6,4</sup>	9(a)
Poly-block twin clamp hanger (assembled with welding stud) <sup>5,6,4</sup>	9(b)
Poly-block twin clamp hanger (assembled with mounting channel) <sup>5,6,4</sup>	9(c)
Crimp-on weld stud-type hangers	10
Banded weld stud-type hanger	11
Poly-block single-clamp hanger (assembled with welding plate) <sup>4,6</sup>	12(a)
Poly-block single-clamp hanger (assembled with welding stud) <sup>4,6</sup>	12(b)
Poly-block single-clamp hanger (assembled with mounting channel) <sup>4,6</sup>	12(c)

<sup>3</sup> The sole source of supply of the apparatus known to the committee at this time is TRW Nelson Div., Toledo Ave. and E. 28th St., Lorain, OH 44055.

<sup>4</sup> If you are aware of alternative suppliers, please provide this information to ASTM International Headquarters. Your comments will receive careful consideration at a meeting of the responsible technical committee<sup>1</sup>, which you may attend.

<sup>5</sup> The sole source of supply of the apparatus known to the committee at this time is Stauff Corp., 41 Newman St., Hackensack, NJ 07601.

<sup>6</sup> The sole source of supply of the poly-block hangers known to the committee at this time is Behringer Corp., 108 Jabez St., Newark, NJ 07105.

**5. Hanger Designs**

5.1 Figs. 1-5 and Fig. 6(a) hangers are designs generally manufactured by shipyards or their subcontractors. See also Tables 1-6.

5.2 Fig. 6, Fig. 8, Fig. 10, and Fig. 11 hangers are commercially available from various vendors. Fig. 8, Fig. 10, and Fig. 11 hangers are primarily designed for use in supporting electrical cables, but are suitable for hanging small size pipe and tubing.

5.2.1 The Fig. 7 hanger<sup>3,4</sup> is a specific design that has been patented by Nelson Division of TRW.

5.2.2 The Fig. 9 and Fig. 12 hangers<sup>5,6,4</sup> are primarily designed for use when supporting multiple runs of pipe or tubing.

**6. Materials and Manufacture**

6.1 Hanger materials for straps, saddles, and U-bolts for Figs. 1-5 hangers and standoffs should be fabricated from commercial quality carbon steel. The steel should be a weldable grade with a minimum tensile strength of 47 ksi (324 MPa) and capable of being bent at room temperature through 90° to an inside radius equal to the material thickness without cracking on the outside of the bend.

6.2 Hangers in Fig. 1, Fig. 6, Fig. 7, Fig. 10, and Fig. 11 are generally manufactured from carbon steel. Fig. 8 is furnished in carbon steel and stainless steel. Fig. 9 and Fig. 12 hanger clamp halves are injected molded plastic furnished with carbon steel or stainless steel hardware.

6.3 Bands and buckles for Fig. 6 and Fig. 11 hangers should be carbon steel electroplated zinc or stainless steel.

6.4 Hanger bolts and nuts should be regular series hex type electroplated zinc with unified national coarse threads Class 2 fit in accordance with Specification A307, Grade B.

6.5 Table 7 is a listing of hanger liner materials generally used to isolate the pipe from the hanger (see 9.1.1).

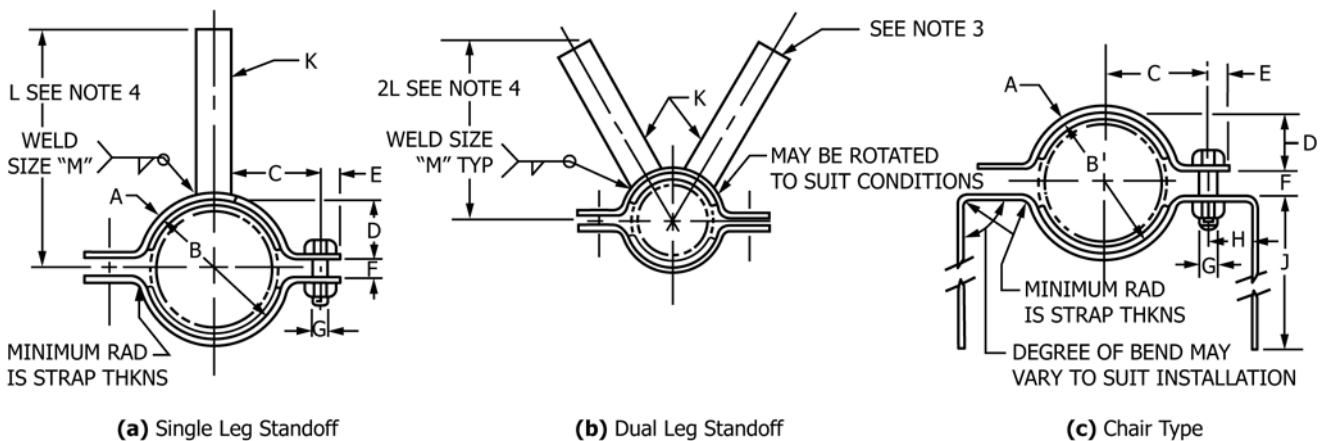

NOTE 1—For dimensions of hangers, see Table 1.

NOTE 2—These hangers are suitable for use in all locations, including tanks and areas exposed to the weather, and can be used lined or unlined.

NOTE 3—For Fig. 1(b), length of standoff legs may be unequal and angle of attachment may vary as required to suit conditions.

NOTE 4—Maximum length of standoff “L” shall be as follows: flat bar = 18 in.; pipe = 30 in.; and angle bar = 42 in.

**FIG. 1 Split Cap Hangers**

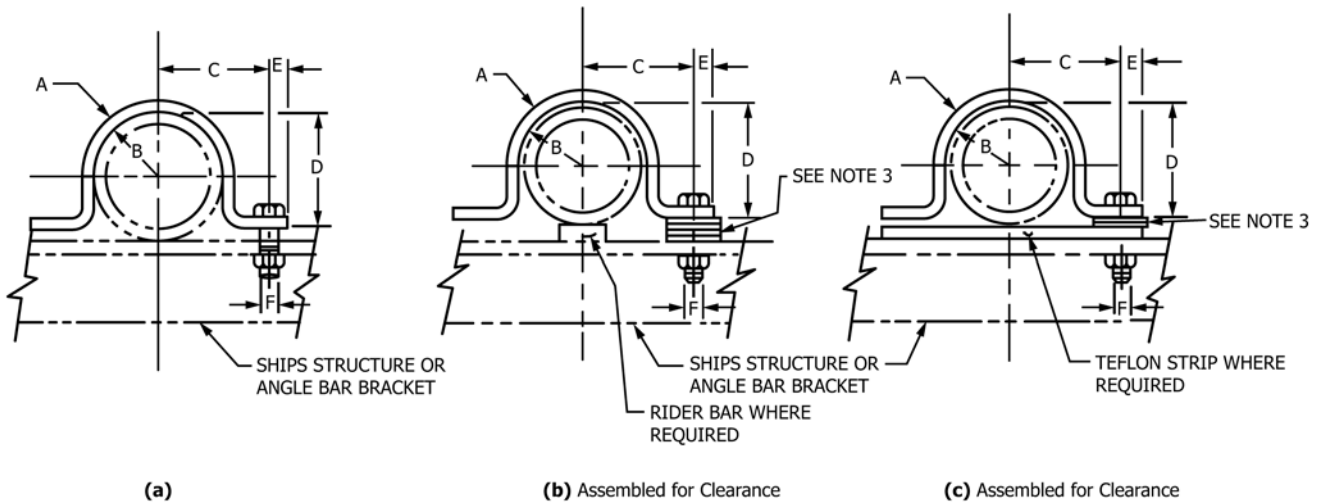

FIG. 2 Strap Hangers

NOTE 1—For dimensions of hangers, see Table 2.  
 NOTE 2—These hangers are suitable for use in all locations, including tanks and areas exposed to the weather, and can be used lined or unlined.  
 NOTE 3—Install standard flat washers as necessary to unlined strap to provide 1/32 to 1/8-in. (0.8 to 3.2-mm) clearance for linear motion of piping when required.

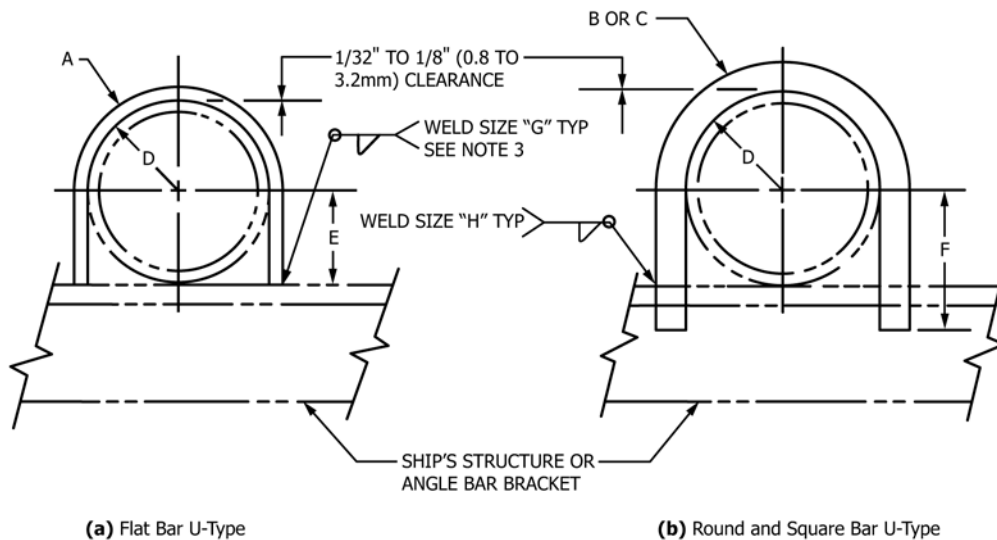

FIG. 3 Welded Hangers

NOTE 1—For dimensions of hangers, see Table 3.  
 NOTE 2—These hangers are suitable for use in all locations, including tanks and areas exposed to the weather, and are intended to be used unlined only.  
 NOTE 3—Weld as indicated for size 3-in. NPS and above. For 2 1/2-in. NPS and below, weld hanger on outside only.

**7. Application and Limitations**

7.1 Unless otherwise noted, application and limitations on the use of various style hangers should be as noted with each hanger detail.

**8. Hanger Spacing**

8.1 Table 8 provides general guidance in determining pipe hanger spacing. Special consideration should be given to areas

of concentrated loads, such as risers, valves, or groups of fittings, and to piping configurations that could create rotational forces.

**9. General Requirements**

9.1 The following general requirements and conditions are applicable to all styles of hangers:

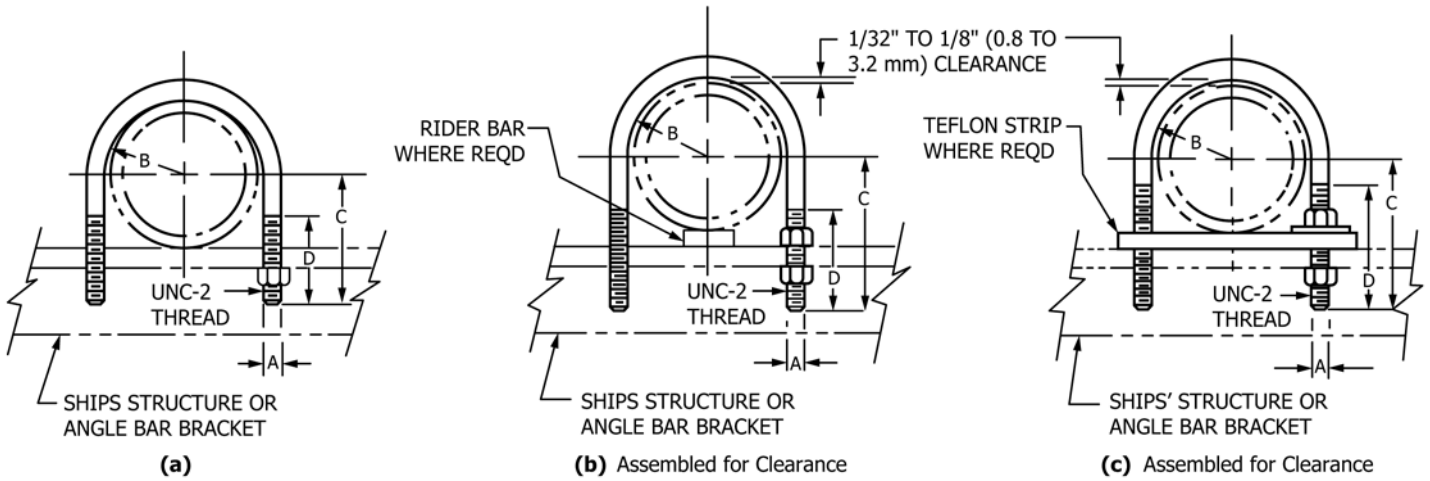

NOTE 1—For dimensions of hangers, see Table 4.

NOTE 2—These hangers are suitable for use in all locations, including tanks and areas exposed to the weather, and are intended to be used unlined.

FIG. 4 U-Bolt Hangers

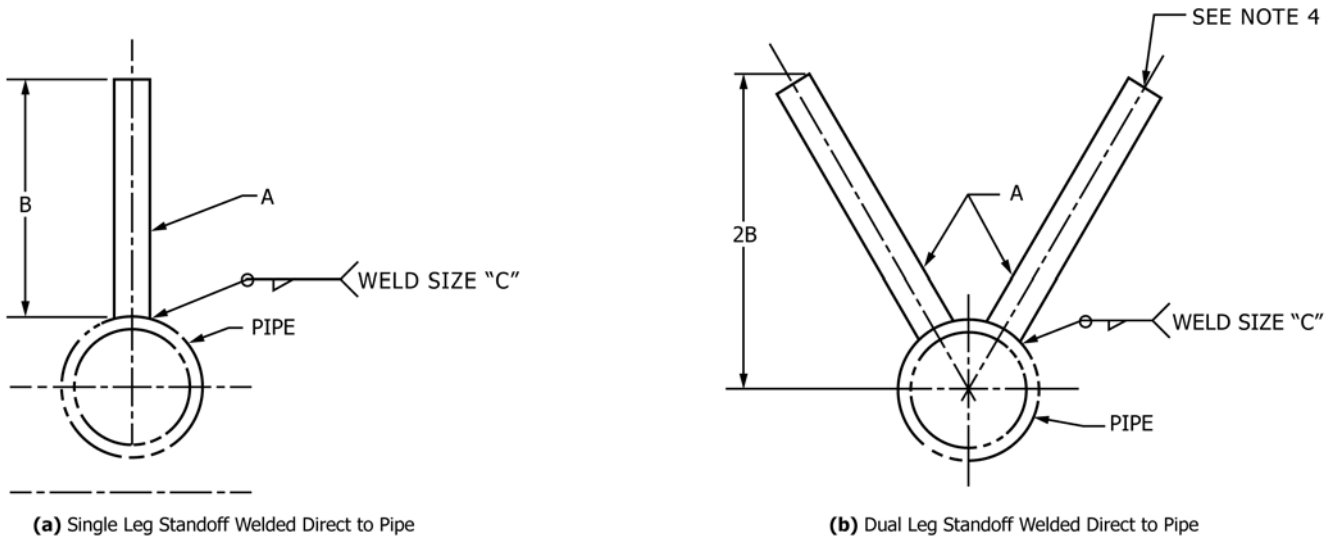

NOTE 1—For dimensions of hangers, see Table 5.

NOTE 2—These hangers are limited to use on normally dry ferrous piping systems, such as sounding tubes. Air escapes and plumbing drains with a wall thickness of 0.200 in. (5.1 mm) or more.

NOTE 3—These hangers should not be used where takedown is required or in the steering gear room, inner bottoms, fore peak, aft peak or deep tanks, or other high vibration or inaccessible areas.

NOTE 4—For Fig. 5(b), length of standoff legs may be unequal and angle of attachment may vary as required to suit conditions.

FIG. 5 Welded Hangers

9.1.1 Hangers need not be lined unless the hanger and pipe are of dissimilar material, or when the system internal operating temperature is 300°F (149°C) and over, or 50°F (10°C) and under and the heat transmitted to the other side of the structure to which the hanger is attached may be objectionable. For hanger liner materials, see 6.5.

9.1.2 All hanger bolts within tanks or other inaccessible areas shall be secured with lock nuts, lock washers, or by some other means.

9.1.3 Pipe hangers and standoffs located in areas subject to corrosion, such as in bilges, ballast tanks, and areas exposed to the weather, should be zinc-plated or blasted and coated with inorganic zinc or coated with the same material as that of the surrounding area.

9.1.4 Standoffs fabricated from pipe should not be used within tanks.

9.1.5 Where thermal growth of piping exceeds 0.100 in. (2.5 mm) or long runs of pipe are affected by ship flexing, such as

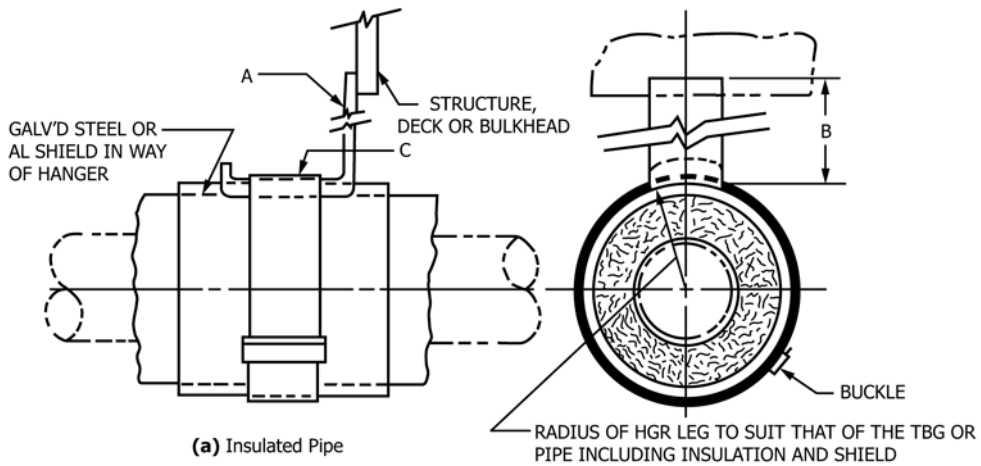

NOTE 1—For dimensions of hangers, see Table 6.

NOTE 2—These hangers are suitable for use in all locations, except tanks and areas exposed to the weather, and can be used lined or unlined.

FIG. 6 J-Band Type Hangers

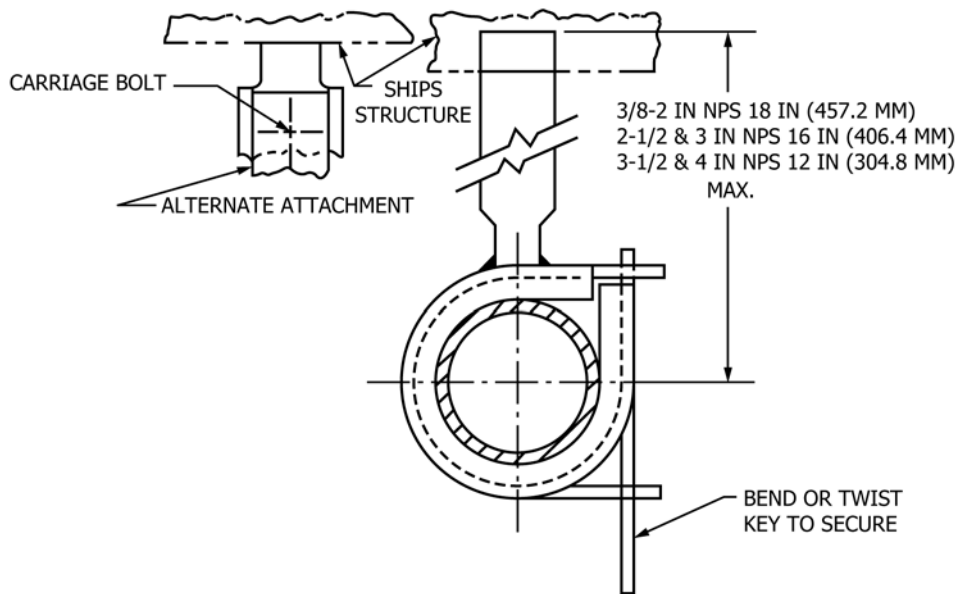

NOTE 1—This hanger is suitable for use in all locations except tanks.

NOTE 2—This hanger is limited to use on pipe 4-in. NPS and below with a system operating temperature of 200°F (93.3°C) or less.

FIG. 7 Nelson Hanger

long runs on the weather deck, or long runs in longitudinal passageways, a metal rider bar attached to the pipe or a

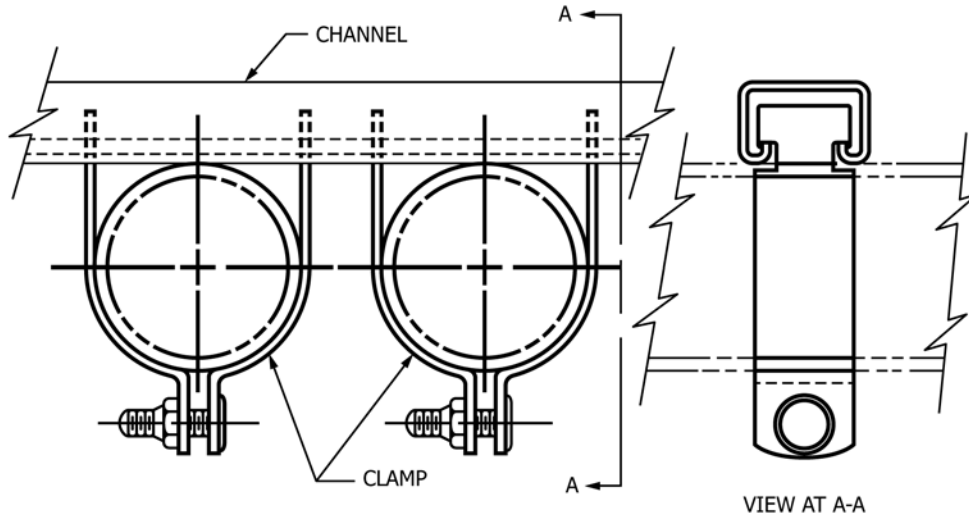

NOTE 1—These hangers are suitable for use in all locations, including tanks and areas exposed to the weather. When used in areas subject to high corrosion, such as salt water ballast tanks or weather decks, stainless steel hanger components shall be used.

NOTE 2—These hangers are suitable for supporting single or multiple runs of piping 2 in. (50.8 mm) or smaller.

**FIG. 8 Clamp Hanger Assembled with Mounting Channel**

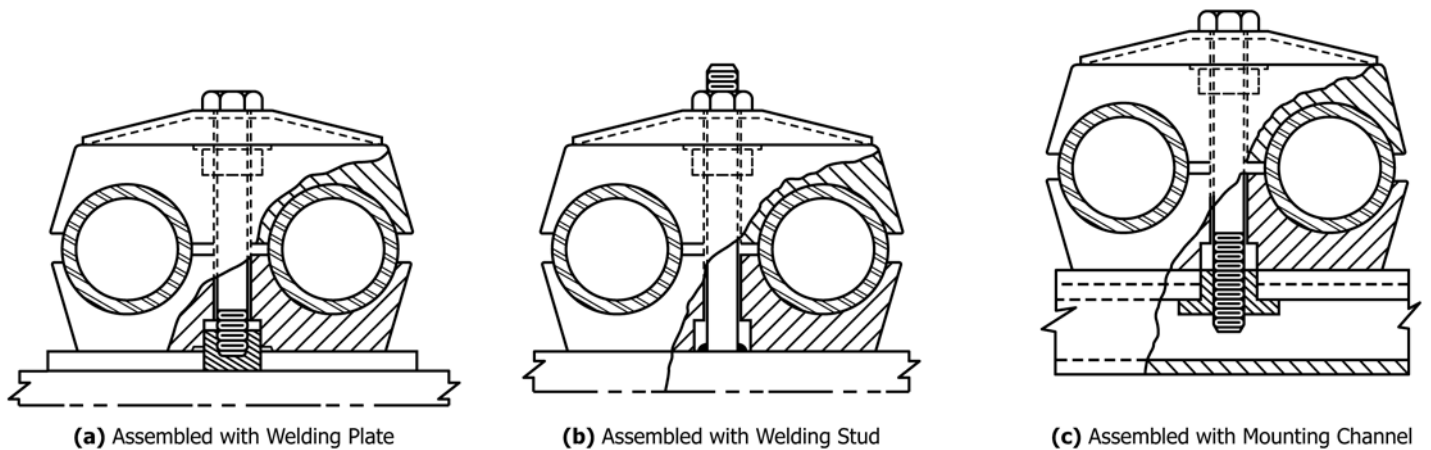

NOTE 1—These hangers are suitable for use in all locations, including tanks and areas exposed to the weather. When used in areas subject to high corrosion, such as salt water ballast tanks or weather decks, stainless steel hanger components shall be used.

NOTE 2—These hangers are limited to use on pipe 1¼-in. NPS and below and tubing 1½-in. outside diameter and below with a system operating temperature of 300°F (149°C) or less.

NOTE 3—These hangers may be used for multiple pipe installations installed vertically, horizontally, or stacked using a welding plate, welding stud, or attached to a mounting channel.

**FIG. 9 Stauff Twin Clamp Hanger<sup>4, 5, 6</sup>**

TFE-fluorocarbon wear strip should be used in conjunction with a clearance type hanger, or other means should be provided to prevent chaffing of the pipe.

9.1.6 Consideration should be given to thermal growth of the piping when selecting or locating hangers so as not to overstress the piping or hangers.

9.1.7 Nonmetallic pipe should be hung in accordance with the manufacturer's recommendations.

## 10. Workmanship, Finish, and Appearance

10.1 Finished hanger components shall have a workman-like appearance and be free of cracks or other injurious defects. Surface scale, rust, welding slag, or any foreign material (such as oil) shall be removed before painting or coating.



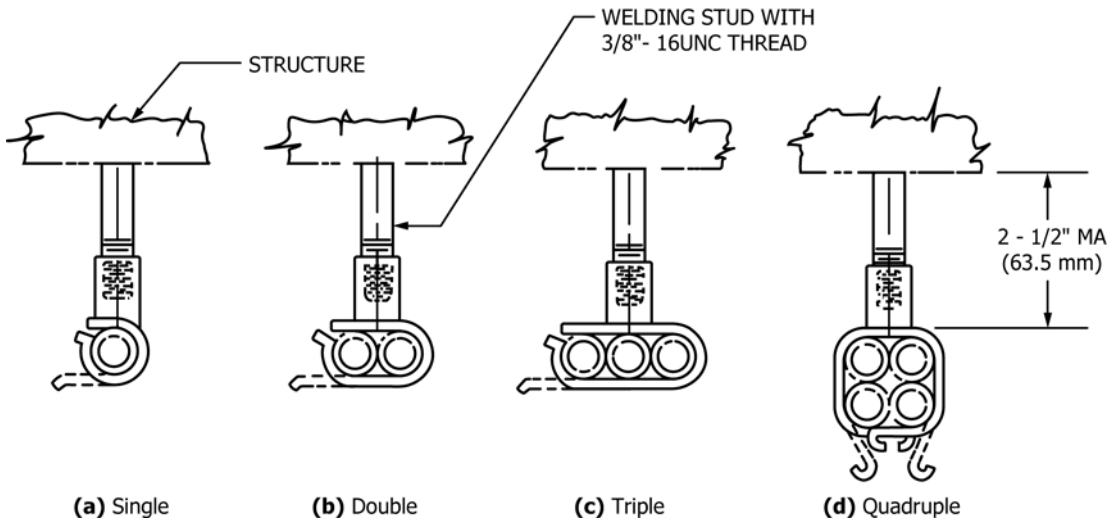

NOTE 1—These hangers are suitable for use in all locations, except tanks, and should be coated with neoprene or other similar material when used to support nonferrous tubing.

NOTE 2—These hangers are limited to use on tubing with an outside diameter of 1½ in. (28.6 mm) or smaller with a system operating temperature of 180°F (82.2°C) or less.

NOTE 3—Size and quantity of tubes may be varied provided they are arranged so as to be securely clamped.

FIG. 10 Crimp-On Weld Stud Hangers

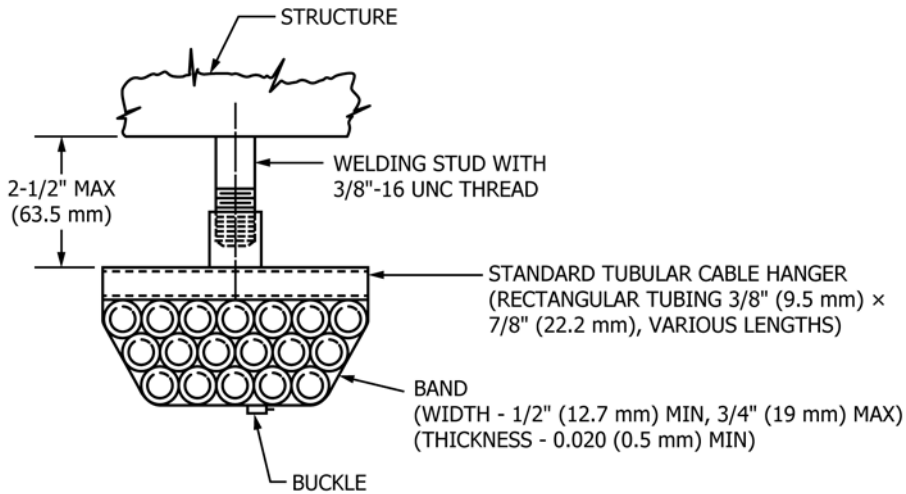

NOTE 1—These hangers are suitable for use in all locations except tanks.

NOTE 2—These hangers are limited to use on tubing with an outside diameter of ½ in. (12.7 mm) or smaller with a system operating temperature of 180°F (82.2°C) or less.

NOTE 3—Size and quantity of tube may be varied, provided they are arranged so as to be securely clamped.

FIG. 11 Banded Weld Stud Hanger

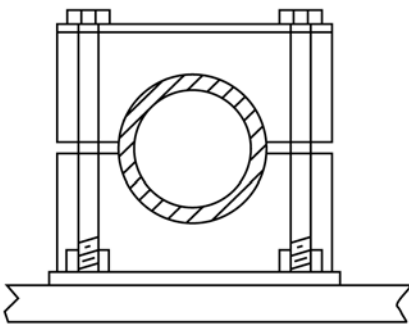

12(a) Assembled With Welding Plate

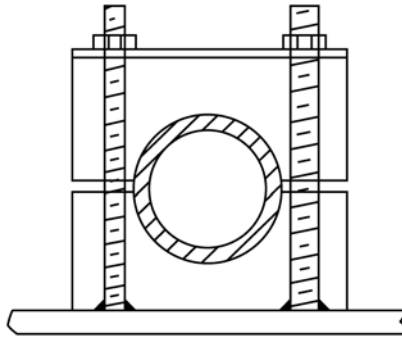

12(b) Assembled With Welding Stud

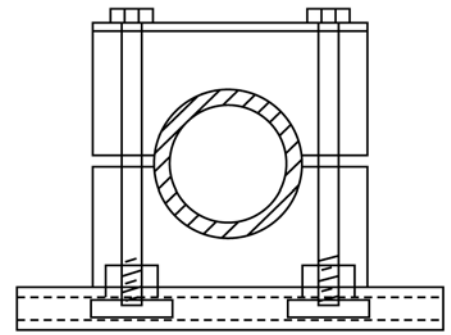

12(c) Assembled With Mounting Channel

NOTE 1—These single poly-block hangers are available in Standard Duty and Heavy Duty Series dependent upon application.

NOTE 2—These hangers are suitable for use in all locations, including tanks and areas exposed to the weather. When used in areas subject to high corrosion, such as salt water ballast tanks or weather decks, stainless steel hanger components shall be used.

NOTE 3—These hangers are limited to use on pipe 8-in. NPS and below and tubing 8-in. outside diameter and below with a system operating temperature of 300°F (149°C) or less.

NOTE 4—These hangers may be used for multiple pipe installations installed vertically, horizontally, or stacked using a weld plate, weld stud, or attached to a mounting channel.

FIG. 12 Poly-block Clamp Hangers

TABLE 1 Dimensions for Split Cap Hangers (Fig. 1)

Nominal Pipe Size, in.	Copper Water Tube Size, in.	A Size of Flat Bar, min., in. <sup>4</sup>	B Inside Diameter of Strap, in. <sup>4</sup>	C Centerline of Pipe to Centerline of Bolt, min., in. <sup>4</sup>	D Height of Strap, in. <sup>4</sup>	E Centerline of Bolt to End of Strap, in. <sup>4</sup>	F Clearance at Bolts (without liner), in. <sup>4</sup>	G Bolt Diameter, min., in. <sup>4</sup>	H Centerline of Bolt to Hanger Leg, in. <sup>4</sup>	J Length, max., in.	K Size of Standoff			M Size of Weld, in. <sup>4</sup>
											Flat Bar, min., in. <sup>4</sup>	Schedule 80 Nominal Pipe Size, min., in. <sup>4</sup>	Angle Bar, min., in. <sup>4</sup>	
...	3/8	1/8 x 3/4	3/4	15/16	3/16	5/16	1/8	1/4	1/2	6	3/16 x 3/4	1/2	3/4 x 3/4 x 1/8	1/8
1/4	...	1/8 x 3/4	13/16	15/16	13/64	5/16	1/8	1/4	1/2	6	3/16 x 3/4	1/2	3/4 x 3/4 x 1/8	1/8
...	1/2	1/8 x 3/4	7/8	1	1/4	5/16	1/8	1/4	1/2	6	3/16 x 3/4	1/2	3/4 x 3/4 x 1/8	1/8
3/8	...	1/8 x 3/4	15/16	1	9/32	5/16	1/8	1/4	1/2	6	3/16 x 3/4	1/2	3/4 x 3/4 x 1/8	1/8
...	5/8	1/8 x 3/4	1	1 1/16	5/16	5/16	1/8	1/4	1/2	6	3/16 x 3/4	1/2	3/4 x 3/4 x 1/8	1/8
1/2	...	1/8 x 3/4	1 1/8	1 1/8	23/64	5/16	1/8	1/4	1/2	6	3/16 x 3/4	1/2	3/4 x 3/4 x 1/8	1/8
...	3/4	1/8 x 3/4	1 1/8	1 1/8	3/8	5/16	1/8	1/4	1/2	6	3/16 x 3/4	1/2	3/4 x 3/4 x 1/8	1/8
3/4	...	1/8 x 1	1 5/16	1 1/4	15/32	3/8	1/8	5/16	5/8	6	1/4 x 1	3/4	1 x 1 x 1/4	1/8
...	1	1/8 x 1	1 3/8	1 1/4	1/2	3/8	1/8	5/16	5/8	6	1/4 x 1	3/4	1 x 1 x 1/4	1/8
1	...	1/8 x 1	1 9/16	1 3/8	19/32	3/8	1/8	5/16	5/8	6	1/4 x 1	3/4	1 x 1 x 1/4	1/8
...	1 1/4	1/8 x 1	1 5/8	1 3/8	5/8	3/8	1/8	5/16	5/8	6	1/4 x 1	3/4	1 x 1 x 1/4	1/8
...	1 1/2	1/8 x 1	1 7/8	1 9/16	3/4	3/8	1/8	5/16	5/8	6	1/4 x 1	3/4	1 x 1 x 1/4	1/8
1 1/4	...	1/8 x 1	1 15/16	1 9/16	49/64	3/8	1/8	5/16	5/8	6	1/4 x 1	3/4	1 x 1 x 1/4	1/8
1 1/2	...	1/8 x 1	2 5/16	1 11/16	57/64	3/8	1/8	5/16	5/8	6	1/4 x 1	3/4	1 x 1 x 1/4	1/8
...	2	1/8 x 1	2 3/8	1 13/16	1	3/8	1/8	5/16	5/8	6	1/4 x 1	3/4	1 x 1 x 1/4	1/8
2	...	1/8 x 1	2 5/8	2	1 1/8	3/8	1/8	5/16	5/8	6	1/4 x 1	3/4	1 x 1 x 1/4	1/8
...	2 1/2	1/4 x 1	2 7/8	2 1/4	1 1/4	3/8	3/8	3/4	3/4	6	1/4 x 1	3/4	1 x 1 x 1/4	1/8
2 1/2	...	1/4 x 1	3 1/8	2 3/8	1 5/16	7/16	1/4	3/8	3/4	8	1/4 x 1	3/4	1 x 1 x 1/4	5/32
...	3	1/4 x 1	3 3/8	2 1/2	1 7/16	7/16	1/4	3/8	3/4	8	1/4 x 1	3/4	1 x 1 x 1/4	5/32
...	...	1/4 x 1	3 3/4	2 11/16	1 5/8	7/16	1/4	3/8	3/4	8	1/4 x 1	3/4	1 x 1 x 1/4	5/32
...	3 1/2	1/4 x 1	3 7/8	2 13/16	1 11/16	7/16	1/4	3/8	3/4	8	1/4 x 1	3/4	1 x 1 x 1/4	5/32
3 1/2	...	1/4 x 1	4 1/4	2 15/16	1 7/8	7/16	1/4	3/8	3/4	8	1/4 x 1	3/4	1 x 1 x 1/4	5/32
...	4	1/4 x 1 1/4	4 3/8	3 1/4	1 15/16	7/16	1/4	3/8	3/4	10	1/4 x 1	3/4	1 x 1 x 1/4	5/32
4	...	1/4 x 1 1/4	4 3/4	3 3/8	2 1/16	9/16	3/8	1/2	1	10	1/4 x 1 1/4	1	1 1/4 x 1 1/4 x 1/4	5/32
5	...	1/4 x 1 1/4	5 13/16	3 15/16	2 19/32	9/16	3/8	1/2	1	10	1/4 x 1 1/4	1	1 1/4 x 1 1/4 x 1/4	5/32
6	...	1/4 x 2	6 7/8	4 1/2	3 1/8	9/16	3/8	1/2	1	12	1/4 x 2	1	2 x 2 x 3/8	5/32
8	...	1/4 x 2	8 7/8	5 3/8	4 1/8	3/4	3/8	5/8	1 1/4	12	1/4 x 2	1 1/2	2 x 2 x 3/8	3/16
10	...	3/8 x 2	11	6 7/8	5 1/8	3/4	1/2	5/8	1 1/4	14	3/8 x 2	1 1/2	2 x 2 x 3/8	3/16
12	...	3/8 x 2	13	7 7/8	6 1/8	3/4	1/2	5/8	1 1/4	14	3/8 x 2	1 1/2	2 x 2 x 3/8	3/16
14	...	1/2 x 2	14 1/4	8 3/4	6 11/16	7/8	5/8	3/4	1 1/2	14	1/2 x 2	1 1/2	2 x 2 x 3/8	3/16
16	...	1/2 x 2	16 1/4	9 3/4	7 11/16	7/8	3/4	3/4	1 1/2	14	1/2 x 2	1 1/2	2 x 2 x 3/8	3/16
18	...	1/2 x 2 1/2	18 1/4	11	8 11/16	1	5/8	7/8	1 3/4	14	1/2 x 2 1/2	2	2 1/2 x 2 1/2 x 3/8	7/32
20	...	1/2 x 2 1/2	20 1/4	12	9 11/16	1	5/8	7/8	1 3/4	14	1/2 x 2 1/2	2	2 1/2 x 2 1/2 x 3/8	7/32
22	...	1/2 x 3	22 1/4	13 1/8	10 11/16	1 1/8	5/8	1	2	14	1/2 x 3	2 1/2	3 x 3 x 3/8	7/32
24	...	1/2 x 3	24 1/4	14 1/8	11 11/16	1 1/8	5/8	1	2	14	1/2 x 3	2 1/2	3 x 3 x 3/8	7/32

<sup>4</sup> 1 in. = 25.4 mm.





TABLE 2 Dimensions for Strap Hangers (Fig. 2)

Nominal Pipe Size, in.	A Size of Flat Bar, min, in. <sup>A</sup>	B Inside Radius of Strap, in. <sup>A</sup>	C Centerline of Pipe to Centerline of Bolt, min, in. <sup>A</sup>		D Height of Strap, in. <sup>A</sup>	E Centerline of Bolt to End of Strap, in. <sup>A</sup>	F Bolt Diameter, min, in. <sup>A</sup>
			Tight	Clearance			
1/4	1/8 x 3/4	13/32	15/16		1/2	5/16	1/4
3/8	1/8 x 3/4	15/32	1		5/8	5/16	1/4
1/2	1/8 x 3/4	9/16	1 1/8		5 1/64	5/16	1/4
3/4	1/8 x 1	2 1/32	1 1/4		1	3/8	5/16
1	1/8 x 1	2 5/32	1 3/8		1 1/4	3/8	5/16
1 1/4	1/8 x 1	3 1/32	1 9/16		1 19/32	3/8	5/16
1 1/2	1/8 x 1	1 3/32	1 1 1/16		1 13/16	3/8	5/16
2	1/8 x 1	1 5/16	2		2 13/16	3/8	5/16
2 1/2	1/4 x 1	1 9/16	2 3/8		2 5/8	7/16	3/8
3	1/4 x 1	1 7/8	2 1 1/16		3 1/4	7/16	3/8
3 1/2	1/4 x 1	2 1/8	2 1 5/16		3 3/4	7/16	3/8
4	1/4 x 1 1/4	2 3/8	3 3/8		4 3/16	9/16	1/2
5	1/4 x 1 1/4	2 29/32	3 1 5/16		5 1/4	9/16	1/2
6	1/4 x 2	3 7/16	4 1/2		6 5/16	9/16	1/2
8	1/4 x 2	4 7/16	5 3/8		8 5/16	3/4	5/8
10	3/8 x 2	5 1/2	6 7/8		10 1/4	3/4	5/8
12	3/8 x 2	6 1/2	7 7/8		12 1/4	3/4	5/8
14	1/2 x 2	7 1/8	8 3/4		13 3/8	7/8	3/4
16	1/2 x 2	8 1/8	9 3/4		15 3/8	7/8	3/4
18	1/2 x 2 1/2	9 1/8	11		17 3/8	1	7/8
20	1/2 x 2 1/2	10 1/8	12		19 3/8	1	7/8
22	1/2 x 3	11 1/8	13 1/8		21 3/8	1 1/8	1
24	1/2 x 3	12 1/8	14 1/8		23 3/8	1 1/8	1

<sup>A</sup> 1 in. = 25.4 mm.

TABLE 3 Dimensions for Welded Hangers (Fig. 3)

Nominal Pipe Size, in.	Size of Bar Stock, min, in. <sup>A</sup>			Inside Radius of Strap, in. <sup>A</sup>		Length of Strap, in. <sup>A</sup>			Size of Weld, in. <sup>A</sup>	
	A Flat Bar	B Round Bar	C Square Bar	D		E Flat Bar Hanger, in. <sup>A</sup>		F Round or Square Bar Hanger, in. <sup>A</sup>	G	H
				Tight	Clearance	Tight	Clearance			
1/4	1/8 x 1/2	1/4	1/4	9/32	1 1/32	7/32	1 3/32	2 1/32	1/8	1/8
3/8	1/8 x 1/2	1/4	1/4	1 1/32	1 3/32	9/32	1 5/32	2 3/32	1/8	1/8
1/2	1/8 x 1/2	1/4	1/4	2 7/64	3 1/64	2 3/64	3 5/64	1 3/16	1/8	1/8
3/4	1/8 x 1	3/8	3/8	1 7/32	1 9/32	1 5/32	2 1/32	2 9/32	1/8	3/16
1	1/8 x 1	3/8	3/8	2 1/32	2	1 9/32	2 5/32	1 1/8	1/8	3/16
1 1/4	1/8 x 1	3/8	3/8	5 3/64	5 7/64	4 9/64	6 1/64	1 5/16	1/8	3/16
1 1/2	1/8 x 1	3/8	3/8	6 1/64	1 1/64	5 7/64	1 5/64	1 7/16	1/8	3/16
2	1/8 x 1	3/8	3/8	1 3/16	1 1/4	1 1/8	1 5/8	1 1 1/16	1/8	3/16
2 1/2	1/4 x 1	1/2	1/2	1 7/16	1 1/2	1 3/8	1 9/16	2	3/16	1/4
3	1/4 x 1	1/2	1/2	1 3/4	1 13/16	1 1 1/16	1 7/8	2 5/16	3/16	1/4
3 1/2	1/4 x 1	1/2	1/2	2	2 1/16	2 1/16	2 1/8	2 9/16	3/16	1/4
4	1/4 x 1 1/2	1/2	1/2	2 1/4	2 5/16	2 3/16	2 3/8	2 1 3/16	3/16	1/4
5	1/4 x 1 1/2	1/2	1/2	2 25/32	2 27/32	2 23/32	2 29/32	3 3/8	3/16	1/4
6	3/8 x 2	3/4	3/4	3 5/16	3 3/8	3 1/4	3 7/16	4 1/16	3/16	5/16
8	3/8 x 2	3/4	3/4	4 5/16	4 3/8	4 1/4	4 7/16	5 1/16	3/16	5/16
10	1/2 x 2	1 1/8	1	5 3/8	5 7/16	5 5/16	5 1/2	6 1/8	1/4	5/16
12	1/2 x 2	1 1/8	1	6 3/8	6 7/16	6 5/16	6 1/2	7 1/2	1/4	3/8
14	5/8 x 3	1 1/2	1 3/8	7	7 1/16	6 1 5/16	7 1/8	8 1/8	3/8	3/8
16	5/8 x 3	1 1/2	1 3/8	8	8 1/16	7 1 5/16	8 1/8	9 1/8	3/8	3/8
18	5/8 x 3	1 1/2	1 3/8	9	9 1/16	8 1 5/16	9 1/8	10 1/8	3/8	3/8
20	5/8 x 3	1 1/2	1 3/8	10	10 1/16	9 1 5/16	10 1/8	11 1/2	3/8	1/2
22	5/8 x 3	1 1/2	1 3/8	11	11 1/16	10 1 5/16	11 1/8	12 1/2	3/8	1/2
24	5/8 x 3	1 1/2	1 3/8	12	12 1/16	11 1 5/16	12 1/8	13 1/2	3/8	1/2

<sup>A</sup> 1 in. = 25.4 mm.

**TABLE 4 Dimensions for U-Bolt Hangers (Fig. 4)**

NOTE 1—U-bolt dimensions are presently under review. Some sizes specified in this table are considered to be excessive for the intended service and some are not commercially available as standard products. A revision will be processed when the review is completed.

Nominal Pipe Size, in.	A Rod Diameter, min, in. <sup>A</sup>	B Inside Radius of U-bolt, min, in. <sup>A</sup>	C Length (approximate), in. <sup>A</sup>	D Thread Length, min, in. <sup>A</sup>
1/4	1/4	19/64	1 13/16	1 13/16
3/8	1/4	23/64	1 7/8	1 13/16
1/2	1/4	7/16	1 13/16	1 13/16
3/4	3/8	35/64	2 1/8	2 1/8
1	3/8	1 1/16	2 5/16	2 1/8
1 1/4	3/8	55/64	2 1/2	2 1/8
1 1/2	3/8	63/64	2 5/8	2 1/8
2	3/8	17/32	2 7/8	2 1/8
2 1/2	1/2	1 15/32	3 1/4	2 3/8
3	1/2	1 25/32	3 9/16	2 3/8
3 1/2	1/2	2 1/32	3 13/16	2 3/8
4	1/2	2 9/32	4 1/16	2 3/8
5	1/2	2 19/16	4 9/16	2 3/8
6	3/4	3 3/8	5 3/8	2 3/4
8	3/4	4 3/8	6 3/8	2 3/4
10	1 1/8	5 7/16	7 13/16	3 1/2
12	1 1/8	6 7/16	8 13/16	3 1/2
14	1 1/2	7 1/16	9 13/16	4 1/2
16	1 1/2	8 1/16	10 13/16	4 1/2
18	1 1/2	9 1/16	11 13/16	4 1/2
20	1 1/2	10 1/16	12 13/16	4 1/2
22	1 1/2	11 1/16	13 13/16	4 1/2
24	1 1/2	12 1/16	14 13/16	4 1/2
26	1 1/2	13 1/16	15 13/16	4 1/2
28	1 1/2	14 1/16	16 13/16	4 1/2
30	1 1/2	15 1/16	17 13/16	4 1/2
32	2	16 1/16	19 5/16	5 1/4
34	2	17 1/16	20 5/16	5 1/4
36	2	18 1/16	21 5/16	5 1/4

<sup>A</sup> 1 in. = 25.4 mm.

**TABLE 5 Dimensions for Welded Hanger (Fig. 5)**

Nominal Pipe Size, in.	A Size of Standoff		Pipe, NPS Schedule 80, min.	B Length (Max)			C Size of Weld, in. <sup>A</sup>
	Flat Bar, min, in. <sup>A</sup>	Angle Bar, min, in. <sup>A</sup>		Flat Bar, in. <sup>A</sup>	Pipe, in. <sup>A</sup>	Angle Bar, in. <sup>A</sup>	
1/2	3/16 x 3/4	3/4 x 3/4 x 1/8	1/2	18	30	42	1/8
3/4	1/4 x 1	1 x 1 x 1/4	3/4	18	30	42	1/8
1	1/4 x 1	1 x 1 x 1/4	3/4	18	30	42	1/8
1 1/4	1/4 x 1	1 x 1 x 1/4	3/4	18	30	42	1/8
1 1/2	1/4 x 1	1 x 1 x 1/4	3/4	18	30	42	1/8
2	1/4 x 1	1 x 1 x 1/4	3/4	18	30	42	1/8
2 1/2	1/4 x 1	1 x 1 x 1/4	3/4	18	30	42	5/32
3	1/4 x 1	1 x 1 x 1/4	3/4	18	30	42	5/32
3 1/2	1/4 x 1	1 x 1 x 1/4	3/4	18	30	42	5/32
4	1/4 x 1 1/4	1 1/4 x 1 1/4 x 1/4	1	18	30	42	5/32
5	1/4 x 1 1/4	1 1/4 x 1 1/4 x 1/4	1	18	30	42	5/32
6	1/4 x 2	2 x 2 x 3/8	1	18	30	42	5/32
8	1/4 x 2	2 x 2 x 3/8	1 1/2	18	30	42	3/16
10	3/8 x 2	2 x 2 x 3/8	1 1/2	18	30	42	3/16
12	3/8 x 2	2 x 2 x 3/8	1 1/2	18	30	42	3/16
14	1/2 x 2	2 x 2 x 3/8	1 1/2	18	30	42	3/16
16	1/2 x 2	2 x 2 x 3/8	1 1/2	18	30	42	3/16
18	1/2 x 2 1/2	2 1/2 x 2 1/2 x 3/8	2	18	30	42	7/32
20	1/2 x 2 1/2	2 1/2 x 2 1/2 x 3/8	2	18	30	42	7/32
22	1/2 x 3	3 x 3 x 3/8	2 1/2	18	30	42	7/32
24	1/2 x 3	3 x 3 x 3/8	2 1/2	18	30	42	7/32

<sup>A</sup> 1 in. = 25.4 mm.



TABLE 6 Dimensions for “J” Band Hanger (Fig. 6)

Nominal Pipe Size, in.	Copper Water Tube Size, in.	A Size of Flat Bar, min, in. <sup>A</sup>	B Length, max, in. <sup>A</sup>	C Size of Band, min, in. <sup>A</sup>
...	3/8	1/8 x 1	15	0.030 x 1/2
1/4	...	1/8 x 1	15	0.030 x 1/2
...	1/2	1/8 x 1	15	0.030 x 1/2
3/8	...	1/8 x 1	15	0.030 x 1/2
...	5/8	1/8 x 1	15	0.030 x 1/2
1/2	...	1/8 x 1	15	0.030 x 1/2
...	3/4	1/8 x 1	15	0.030 x 1/2
3/4	...	1/8 x 1	15	0.030 x 1/2
...	1	1/8 x 1	15	0.030 x 1/2
1	...	1/8 x 1	15	0.030 x 1/2
...	1 1/4	1/8 x 1	15	0.030 x 1/2
...	1 1/2	1/8 x 2	15	0.030 x 5/8
1 1/4	...	1/8 x 2	15	0.030 x 5/8
1 1/2	...	1/8 x 2	15	0.030 x 5/8
...	2	1/8 x 2	15	0.030 x 5/8
2	...	1/8 x 2	15	0.030 x 5/8
...	2 1/2	1/8 x 2	15	0.030 x 5/8
2 1/2	...	3/16 x 2	15	0.030 x 3/4
...	3	3/16 x 2	15	0.030 x 3/4
3	...	3/16 x 2	15	0.030 x 3/4
...	3 1/2	3/16 x 2	15	0.030 x 3/4
3 1/2	...	3/16 x 2	15	0.030 x 3/4
...	4	3/16 x 2	15	0.030 x 3/4
4	...	3/16 x 2	15	0.030 x 3/4

<sup>A</sup> 1 in. = 25.4 mm.

TABLE 7 Pipe Hanger Liner Materials<sup>A,B</sup>

Material	Thickness, in. (mm)	Temperature Range, °F (°C)
Woven fiber glass tape, non-reinforced with salvage edges <sup>C</sup>	1/8 (3.2)	up to 650 (343.3)
Silicon rubber sheet (ZZ-R-765, Class 2, 60 durometer or equal)	1/8 (3.2)	up to 450 (232.2)
Synthetic rubber <sup>D</sup> sheet (MIL-R-6855, Class 2, 60 Durometer or equal)	1/8 (3.2)	up to 180 (82.2)
Sheet lead	1/16 to 1/8 (1.6 to 3.2)	up to 500 (260)
Fluorocarbon elastomer (Viton, Fluorel)	1/8 (3.2)	up to 650 (343.3)

<sup>A</sup> Other materials may be used provided the materials selected are compatible with the intended service and temperature limitations.

<sup>B</sup> Use of asbestos as a hanger liner material shall be prohibited due to the potential health hazard in working with this material.

<sup>C</sup> Similar to Amatex Corp., Thermoglass style G65P752 9731 finish, or Claremont Corp., Claretex Style 19-T-125 or equivalent.

<sup>D</sup> Only oil-resistant synthetic rubber should be used in oil tanks.

**TABLE 8 Pipe Hanger Spacing**

Nominal Pipe Size, in.	Hanger Spacing, ft (m)	Nominal Pipe Size, in.	Hanger Spacing, ft (m)
1/2	5 (1.52)	10	15 (4.57)
3/4	5 (1.52)	12	15 (4.47)
1	6 (1.82)	14	15 (4.47)
1 1/4	6 (1.82)	16	15 (4.47)
1 1/2	6 (1.82)	18	15 (4.47)
2	8 (2.44)	20	15 (4.47)
2 1/2	8 (2.44)	24	20 (6.10)
3	8 (2.44)	26	20 (6.10)
3 1/2	8 (2.44)	28	20 (6.10)
4	8 (2.44)	30	20 (6.10)
5	12 (3.65)	32	20 (6.10)
6	12 (3.65)	34	20 (6.10)
8	12 (3.65)	36	20 (6.10)

ASTM International takes no position respecting the validity of any patent rights asserted in connection with any item mentioned in this standard. Users of this standard are expressly advised that determination of the validity of any such patent rights, and the risk of infringement of such rights, are entirely their own responsibility.

This standard is subject to revision at any time by the responsible technical committee and must be reviewed every five years and if not revised, either reapproved or withdrawn. Your comments are invited either for revision of this standard or for additional standards and should be addressed to ASTM International Headquarters. Your comments will receive careful consideration at a meeting of the responsible technical committee, which you may attend. If you feel that your comments have not received a fair hearing you should make your views known to the ASTM Committee on Standards, at the address shown below.

This standard is copyrighted by ASTM International, 100 Barr Harbor Drive, PO Box C700, West Conshohocken, PA 19428-2959, United States. Individual reprints (single or multiple copies) of this standard may be obtained by contacting ASTM at the above address or at 610-832-9585 (phone), 610-832-9555 (fax), or [service@astm.org](mailto:service@astm.org) (e-mail); or through the ASTM website ([www.astm.org](http://www.astm.org)). Permission rights to photocopy the standard may also be secured from the Copyright Clearance Center, 222 Rosewood Drive, Danvers, MA 01923, Tel: (978) 646-2600; <http://www.copyright.com/>