



Standard Practice for Selecting Bolting Lengths for Piping System Flanged Joints¹

This standard is issued under the fixed designation F704; the number immediately following the designation indicates the year of original adoption or, in the case of revision, the year of last revision. A number in parentheses indicates the year of last reapproval. A superscript epsilon (ϵ) indicates an editorial change since the last revision or reapproval.

This standard has been approved for use by agencies of the U.S. Department of Defense.

1. Scope

1.1 This practice covers bolt and stud bolt lengths, quantities, and thread series for pipe to pipe and pipe to valve flanged joints (**Note 1**) in the nominal pipe size ranges of ½-in. through 48-in. (12.7- through 1219-mm) diameter and pressure range of 125 through 2500 psi (0.8 through 17 236 kPa).

NOTE 1—This is applicable when flange of valve has the same thickness as mating flange.

1.2 The values stated in inch-pound units are to be regarded as standard. The values given in parentheses are mathematical conversions to SI units that are provided for information only and are not considered standard.

1.3 *This standard does not purport to address all of the safety concerns, if any, associated with its use. It is the responsibility of the user of this standard to establish appropriate safety and health practices and determine the applicability of regulatory limitations prior to use.*

2. Referenced Documents

2.1 ANSI Standards:²

B1.1 Unified Screw Threads

B16.1 Cast Iron Pipe Flanges and Flanged Fittings (25, 125, 250, and 800 lb)

B16.5 Steel Pipe Flanges and Flanged Fittings (150, 300, 400, 600, 900, 1500, and 2500 lb Including Reference to Valves)

B16.24 Bronze Flanges and Flanged Fittings (150 and 300 lb)

B18.2.1 Square and Hex Bolts and Screws

B18.2.2 Square and Hex Nuts

2.2 MSS Standards:³

MSS SP-44 Steel Pipe Flanges

3. Bolting Criteria

3.1 Bolt and stud bolt lengths are computed using the following (see **Annex A1**):

3.1.1 Includes maximum nut thickness in accordance with ANSI B18.2.2.

3.1.2 Does not include washer thickness.

3.1.3 Does not include bolt or stud bolt point height.

3.1.4 Includes allowance for up to ⅛-in. (3.2-mm) thick gaskets, except butterfly valves.

3.1.5 Includes ¼-in. (6.3-mm) raised face in addition to flange thickness listed in tables for flanges rated at 400 psi (2.8 kPa) and above.

3.1.6 Includes use of heavy hex nut and bolt design.

3.1.7 Includes plus tolerance for flange thickness in accordance with ANSI B16.5.

3.2 All bolts and stud bolts have threads in accordance with ANSI B1.1, Class 2A dimensioning and nuts Class 2B.

3.3 The material requirements for bolts, stud bolts, and nuts are obtained from the material specifications of individual system diagrams.

3.4 Alloy steel bolting 1-in. (25.4-mm) nominal diameter and smaller and all carbon steel bolting has threads of the UNC Series; alloy steel bolting above 1-in. nominal diameter has threads of the 8-UN Series.

3.5 For detailed descriptions of flange bolting assemblies, butterfly valve bolting assemblies, and tapped lug-type butterfly valve bolting assemblies, refer to Figs. 1–7.

4. List of Tables

4.1 The tables are arranged in the following sequence:

150-lb Steel Flanged Joints
300-lb Steel Flanged Joints
400-lb Steel Flanged Joints

Table 1
Table 2
Table 3

¹ This practice is under the jurisdiction of ASTM Committee F25 on Ships and Marine Technology and is the direct responsibility of Subcommittee F25.11 on Machinery and Piping Systems.

Current edition approved Nov. 1, 2014. Published November 2014. Originally approved in 1981. Last previous edition approved in 2009 as F704 – 81 (2009). DOI: 10.1520/F0704-81R14.

² Available from American National Standards Institute (ANSI), 25 W. 43rd St., 4th Floor, New York, NY 10036, <http://www.ansi.org>.

³ Available from Manufacturers Standardization Society of the Valve and Fittings Industry (MSS), 127 Park St., NE, Vienna, VA 22180-4602, <http://www.mss-hq.com>.



600-lb Steel Flanged Joints **Table 4**
 900-lb Steel Flanged Joints **Table 5**
 1500-lb Steel Flanged Joints **Table 6**
 2500-lb Steel Flanged Joints **Table 7**
 150-lb Bronze Flanged Joints **Table 8**
 300-lb Bronze Flanged Joints **Table 9**
 150-lb Steel Flat Face to 150-lb Bronze Flanged Joints **Table 10**
 300-lb Steel Flat Face to 300-lb Bronze Flanged Joints **Table 11**
 125-lb Cast Iron to 150-lb Steel Flat Face Flanged Joints **Table 12**
 250-lb Cast Iron to 300-lb Steel Flat Face Flanged Joints **Table 13**
 800-lb Cast Iron to 600-lb Steel Flanged Joints **Table 14**
 Wafer-Type Butterfly Valve and 150-lb Steel Flanges **Table 15**
 Wafer-Type Butterfly Valve and 150-lb Bronze Flanges **Table 16**
 Bolting Lengths for Tapped Lug-Type Butterfly Valve and 150-lb Steel Flanges to ANSI B16.5 **Table 17**

Bolting Lengths for Tapped Lug-Type Butterfly Valve and 150 lb Bronze Flanges to ANSI B16.24 **Table 18**

5. Keywords

5.1 bolting lengths; cover bolt; flange joint(s); marine technology; ships; stud bolts

TABLE 1 Bolting Lengths for 150-lb Steel Flanged Joints to ANSI B16.5 and MSS SP-44 (see Fig. 1 and Fig. 2)

Nominal Pipe Size, in.	Bolt Diameter, in. ⁴	Quantity per Joint	Flange Thickness, in. ⁴	Bolt Stud Bolt Thread	Bolt Length Carbon Steel, in. ⁴	Stud Bolt Length Carbon Steel, in. ⁴
1/2	1/2	4	7/16	1/2-13 UNC-2A	1 3/4	2 1/4
3/4	1/2	4	1/2	1/2-13 UNC-2A	2	2 1/2
1	1/2	4	9/16	1/2-13 UNC-2A	2	2 1/2
1 1/4	1/2	4	5/8	1/2-13 UNC-2A	2 1/4	2 3/4
1 1/2	1/2	4	11/16	1/2-13 UNC-2A	2 1/4	2 3/4
2	5/8	4	3/4	5/8-11 UNC-2A	2 3/4	3 1/4
2 1/2	5/8	4	7/8	5/8-11 UNC-2A	3	3 1/2
3	5/8	4	15/16	5/8-11 UNC-2A	3	3 1/2
3 1/2	5/8	8	15/16	5/8-11 UNC-2A	3	3 1/2
4	5/8	8	15/16	5/8-11 UNC-2A	3	3 1/2
5	3/4	8	15/16	3/4-11 UNC-2A	3 1/4	3 3/4
6	3/4	8	1	3/4-10 UNC-2A	3 1/4	4
8	3/4	8	1 1/8	3/4-10 UNC-2A	3 1/2	4 1/4
10	7/8	12	1 3/16	7/8-9 UNC-2A	3 3/4	4 1/2
12	7/8	12	1 1/4	7/8-9 UNC-2A	4	4 3/4
14	1	12	1 3/8	1-8 UNC-2A	4 1/4	5 1/4
16	1	16	1 7/16	1-8 UNC-2A	4 1/2	5 1/4
18	1 1/8	16	1 9/16	1 1/8-7 UNC-2A	5 3/4	
20	1 1/8	20	1 11/16	1 1/8-7 UNC-2A	5 1/4	6 1/4
24	1 1/4	20	1 7/8	1 1/4-7 UNC-2A	5 3/4	6 3/4
26	1 1/4	24	2 1/16	1 1/16-7 UNC-2A	7 1/4	8 1/2
28	1 1/4	28	2 13/16	1 1/4-7 UNC-2A	7 1/2	8 3/4
30	1 1/4	28	2 15/16	1 1/4-7 UNC-2A	7 3/4	9
32	1 1/2	28	3 3/16	1 1/2-6 UNC-2A	8 3/4	10
34	1 1/2	32	3 1/4	1 1/2-6 UNC-2A	8 3/4	10
36	1 1/2	32	3 9/16	1 1/2-6 UNC-2A	9 1/2 10 3/4	
38	1 1/2	32	3 7/16	1 1/2-6 UNC-2A	9 1/4	10 1/2
40	1 1/2	36	3 9/16	1 1/2-6 UNC-2A	9 1/2	10 3/4
42	1 1/2	36	3 13/16	1 1/2-6 UNC-2A	10	11 1/4
44	1 1/2	40	4	1 1/2-6 UNC-2A	10 1/4	11 1/2
46	1 1/2	40	4 1/16	1 1/2-6 UNC-2A	10 1/2	11 3/4
48	1 1/2	44	4 1/4	1 1/2-6 UNC-2A	10 3/4	12 1/4

⁴ 1 in. = 25.4 mm.

TABLE 2 Bolting Lengths for 300-lb Steel Flanged Joints to ANSI B16.5 (see Fig. 1 and Fig. 2)

Nominal Pipe Size, in.	Bolt Diameter, in. ^A	Quantity per Joint	Flange Thickness, in. ^A	Bolt Stud Bolt Thread	Bolt Length Carbon Steel, in. ^A	Stud Bolt Length Carbon Steel, in. ^A
1/2	1/2	4	9/16	1/2-13 UNC-2A	2	2 1/2
3/4	5/8	4	5/8	5/8-11 UNC-2A	2 1/4	3
1	5/8	4	1 1/16	5/8-11 UNC-2A	2 1/2	3
1 1/4	5/8	4	3/4	5/8-11 UNC-2A	2 1/2	3 1/4
1 1/2	3/4	4	13/16	3/4-10 UNC-2A	3	3 1/2
2	5/8	8	7/8	5/8-11 UNC-2A	3	3 1/2
2 1/2	3/4	8	1	3/4-10 UNC-2A	3 1/4	4
3	3/4	8	1 1/8	3/4-10 UNC-2A	3 1/2	4 1/4
3 1/2	3/4	8	1 3/16	3/4-10 UNC-2A	3 3/4	4 1/4
4	3/4	8	1 1/4	3/4-10 UNC-2A	3 3/4	4 1/2
5	3/4	8	1 3/8	3/4-10 UNC-2A	4	4 3/4
6	3/4	12	1 7/16	3/4-10 UNC-2A	4 1/4	4 3/4
8	7/8	12	1 5/8	7/8-8 UNC-2A	4 3/4	5 1/2
10	1	16	1 7/8	1-8 UNC-2A	5 1/4	6 1/4
12	1 1/8	16	2	1 1/8-7 UNC-2A	5 3/4	6 3/4
14	1 1/8	20	2 1/8	1 1/8-7 UNC-2A	6	7
16	1 1/4	20	2 1/4	1 1/4-7 UNC-2A	6 1/4	7
18	1 1/4	24	2 3/8	1 1/4-7 UNC-2A	6 1/2	7 3/4
20	1 1/4	24	2 1/2	1 1/4-7 UNC-2A	7	8
24	1 1/2	24	2 3/4	1 1/2-6 UNC-2A	7 3/4	9

^A 1 in. = 25.4 mm.

TABLE 3 Bolting Lengths for 400-lb Steel Flanged Joints to ANSI B16.5 (see Fig. 3 and Fig. 4)

Nominal Pipe Size, in.	Bolt Diameter, in. ^A	Quantity per Joint	Flange Thickness, in. ^A	Bolt Stud Bolt Thread	Bolt Length Alloy Steel, in. ^A	Stud Bolt Length Alloy Steel, in. ^A
1/2	<i>B</i>	<i>B</i>	<i>B</i>	<i>B</i>	<i>B</i>	<i>B</i>
3/4	<i>B</i>	<i>B</i>	<i>B</i>	<i>B</i>	<i>B</i>	<i>B</i>
1	<i>B</i>	<i>B</i>	<i>B</i>	<i>B</i>	<i>B</i>	<i>B</i>
1 1/4	<i>B</i>	<i>B</i>	<i>B</i>	<i>B</i>	<i>B</i>	<i>B</i>
1 1/2	<i>B</i>	<i>B</i>	<i>B</i>	<i>B</i>	<i>B</i>	<i>B</i>
2	<i>B</i>	<i>B</i>	<i>B</i>	<i>B</i>	<i>B</i>	<i>B</i>
2 1/2	<i>B</i>	<i>B</i>	<i>B</i>	<i>B</i>	<i>B</i>	<i>B</i>
3	<i>B</i>	<i>B</i>	<i>B</i>	<i>B</i>	<i>B</i>	<i>B</i>
3 1/2	<i>B</i>	<i>B</i>	<i>B</i>	<i>B</i>	<i>B</i>	<i>B</i>
4	7/8	8	1 3/8	7/8-9 UNC-2A	not used	5 1/2
5	7/8	8	1 1/2	7/8-9 UNC-2A	not used	5 3/4
6	7/8	12	1 5/8	7/8-9 UNC-2A	not used	6
8	1	12	1 7/8	1-8 UNC-2A	not used	6 3/4
10	1 1/8	16	2 1/8	1 1/8-8 UN-2A	not used	7 1/2
12	1 1/4	16	2 1/4	1 1/4-8 UN-2A	not used	8
14	1 1/4	20	2 3/8	1 1/4-8 UN-2A	not used	8 1/4
16	1 3/8	20	2 1/2	1 3/8-8 UN-2A	not used	8 3/4
18	1 3/8	24	2 5/8	1 3/8-8 UN-2A	not used	9
20	1 1/2	24	2 3/4	1 1/2-8 UN-2A	not used	9 1/2
24	1 3/4	24	3	1 3/4-8 UN-2A	not used	10 1/2

^A 1 in. = 25.4 mm.

^B For dimensions of these pipe sizes, refer to Table 4.



TABLE 4 Bolting Lengths for 600-lb Steel Flanged Joints to ANSI B16.5 (see Fig. 3 and Fig. 4)

Nominal Pipe Size, in.	Bolt Diameter, in. ^A	Quantity per Joint	Flange Thickness, in. ^A	Bolt Stud Bolt Thread	Bolt Length Alloy Steel, in. ^A	Stud Bolt Length Alloy Steel, in. ^A
1/2	1/2	4	9/16	1/2-13 UNC-2A	not used	3
3/4	5/8	4	5/8	5/8-11 UNC-2A	not used	3 1/2
1	5/8	4	11/16	5/8-11 UNC-2A	not used	3 1/2
1 1/4	5/8	4	13/16	5/8-11 UNC-2A	not used	3 3/4
1 1/2	3/4	4	7/8	3/4-10 UNC-2A	not used	4 1/4
2	5/8	8	1	5/8-11 UNC-2A	not used	4 1/4
2 1/2	3/4	8	1 1/8	3/4-10 UNC-2A	not used	4 3/4
3	3/4	8	1 1/4	3/4-10 UNC-2A	not used	5
3 1/2	7/8	8	1 3/8	7/8-9 UNC-2A	not used	5 1/2
4	7/8	8	1 1/2	7/8-9 UNC-2A	not used	5 3/4
5	1	8	1 3/4	1-8 UNC-2A	not used	6 1/2
6	1	12	1 7/8	1-8 UNC-2A	not used	6 3/4
8	1 1/8	12	2 3/16	1 1/8-8 UN-2A	not used	7 1/2
10	1 1/4	16	2 1/2	1 1/4-8 UN-2A	not used	8 1/2
12	1 1/4	20	2 5/8	1 1/4-8 UN-2A	not used	8 3/4
14	1 3/8	20	2 3/4	1 3/8-8 UN-2A	not used	9 1/4
16	1 1/2	20	3	1 1/2-8 UN-2A	not used	10
18	1 5/8	20	3 1/4	1 5/8-8 UN-2A	not used	10 3/4
20	1 5/8	24	3 1/2	1 5/8-8 UN-2A	not used	11 1/4
24	1 7/8	24	4	1 7/8-8 UN-2A	not used	13

^A 1 in. = 25.4 mm.

TABLE 5 Bolting Lengths for 900-lb Steel Flanged Joints to ANSI B16.5 (see Fig. 3 and Fig. 4)

Nominal Pipe Size, in.	Bolt Diameter, in. ^A	Quantity per Joint	Flange Thickness, in. ^A	Bolt Stud Bolt Thread	Bolt Length Alloy Steel, in. ^A	Stud Bolt Length Alloy Steel, in. ^A
1/2	<i>B</i>	<i>B</i>	<i>B</i>	<i>B</i>	<i>B</i>	<i>B</i>
3/4	<i>B</i>	<i>B</i>	<i>B</i>	<i>B</i>	<i>B</i>	<i>B</i>
1	<i>B</i>	<i>B</i>	<i>B</i>	<i>B</i>	<i>B</i>	<i>B</i>
1 1/4	<i>B</i>	<i>B</i>	<i>B</i>	<i>B</i>	<i>B</i>	<i>B</i>
1 1/2	<i>B</i>	<i>B</i>	<i>B</i>	<i>B</i>	<i>B</i>	<i>B</i>
2	<i>B</i>	<i>B</i>	<i>B</i>	<i>B</i>	<i>B</i>	<i>B</i>
2 1/2	<i>B</i>	<i>B</i>	<i>B</i>	<i>B</i>	<i>B</i>	<i>B</i>
3	7/8	8	1 1/2	7/8-9 UNC-2A	not used	5 3/4
4	1 1/8	8	1 3/4	1 1/8-8 UN-2A	not used	6 3/4
5	1 1/4	8	2	1 1/4-8 UN-2A	not used	7 1/2
6	1 1/8	12	2 3/16	1 1/8-8 UN-2A	not used	7 1/2
8	1 3/8	12	2 1/2	1 3/8-8 UN-2A	not used	8 3/4
10	1 3/8	16	2 3/4	1 3/8-8 UN-2A	not used	9 1/4
12	1 3/8	20	3 1/8	1 3/8-8 UN-2A	not used	10
14	1 1/2	20	3 3/8	1 1/2-8 UN-2A	not used	10 3/4
16	1 5/8	20	3 1/2	1 5/8-8 UN-2A	not used	11 1/4
18	1 7/8	20	4	1 7/8-8 UN-2A	not used	12 3/4
20	2	20	4 1/4	2-8 UN-2A	not used	13 3/4
24	2 1/2	20	5 1/2	2 1/2-8 UN-2A	not used	17 1/4

^A 1 in. = 25.4 mm.

^B For dimensions of these pipe sizes, refer to Table 6.



TABLE 6 Bolting Lengths for 1500-lb Steel Flanged Joints to ANSI B16.5 (see Fig. 3 and Fig. 4)

Nominal Pipe Size, in.	Bolt Diameter, in. ^A	Quantity per Joint	Flange Thickness, in. ^A	Bolt Stud Bolt Thread	Bolt Length Alloy Steel, in. ^A	Stud Bolt Length Alloy Steel, in. ^A
1/2	3/4	4	7/8	3/4-10 UNC-2A	not used	4 1/4
3/4	3/4	4	1	3/4-10 UNC-2A	not used	4 1/2
1	7/8	4	1 1/8	7/8-9 UNC-2A	not used	5
1 1/4	7/8	4	1 1/8	7/8-9 UNC-2A	not used	5
1 1/2	1	4	1 1/4	1-8 UNC-2A	not used	5 1/2
2	7/8	8	1 1/2	7/8-9 UNC-2A	not used	5 3/4
2 1/2	1	8	1 5/8	1-8 UNC-2A	not used	6 1/4
3	1 1/8	8	1 7/8	1 1/8-8 UN-2A	not used	7
4	1 1/4	8	2 1/8	1 1/4-8 UN-2A	not used	7 3/4
5	1 1/2	8	2 7/8	1 1/2-8 UN-2A	not used	9 3/4
6	1 3/8	12	3 1/4	1 3/8-8 UN-2A	not used	10 1/4
8	1 5/8	12	3 5/8	1 5/8-8 UN-2A	not used	11 1/2
10	1 7/8	12	4 1/4	1 7/8-8 UN-2A	not used	13 1/4
12	2	16	4 7/8	2-8 UN-2A	not used	14 3/4
14	2 1/4	16	5 1/4	2 1/4-8 UN-2A	not used	16
16	2 1/2	16	5 3/4	2 1/2-8 UN-2A	not used	17 1/2
18	2 3/4	16	6 3/8	2 3/4-8 UN-2A	not used	19 1/2
20	3	16	7	3-8 UN-2A	not used	21 1/4
24	3 1/2	16	8	3 1/2-8 UN-2A	not used	24 1/4

^A 1 in. = 25.4 mm.

TABLE 7 Bolting Lengths for 2500-lb Steel Flanged Joints to ANSI B16.5 (see Fig. 3 and Fig. 4)

Nominal Pipe Size, in.	Bolt Diameter, in. ^A	Quantity per Joint	Flange Thickness, in. ^A	Bolt Stud Bolt Thread	Bolt Length Alloy Steel, in. ^A	Stud Bolt Length Alloy Steel, in. ^A
1/2	3/4	4	1 3/16	3/4-10 UNC-2A	not used	4 3/4
3/4	3/4	4	1 1/4	3/4-10 UNC-2A	not used	5
1	7/8	4	1 3/8	7/8-9 UNC-2A	not used	5 1/2
1 1/4	1	4	1 1/2	1-8 UNC-2A	not used	6
1 1/2	1 1/8	4	1 3/4	1 1/8-8 UN-2A	not used	6 3/4
2	1	8	2	1-8 UNC-2A	not used	7
2 1/2	1 1/8	8	2 1/4	1 1/8-8 UN-2A	not used	7 3/4
3	1 1/4	8	2 5/8	1 1/4-8 UN-2A	not used	8 3/4
4	1 1/2	8	3	1 1/2-8 UN-2A	not used	10
5	1 3/4	8	3 5/8	1 3/4-8 UN-2A	not used	11 3/4
6	2	8	4 1/4	2-8 UN-2A	not used	13 1/2
8	2	12	5	2-8 UN-2A	not used	15
10	2 1/2	12	6 1/2	2 1/2-8 UN-2A	not used	19 1/4
12	2 3/4	12	7 1/4	2 3/4-8 UN-2A	not used	21 1/4

^A 1 in. = 25.4 mm.

TABLE 8 Bolting Lengths for 150-lb Bronze Flanged Joints to ANSI B16.24 (see Fig. 1 and Fig. 2)

Nominal Pipe Size, in.	Bolt Diameter, in. ^A	Quantity per Joint	Flange Thickness, in. ^A	Bolt Stud Bolt Thread	Bolt Length Carbon Steel, in. ^A	Stud Bolt Length Carbon Steel, in. ^A
1/2	1/2	4	5/16	1/2-13 UNC-2A	1 1/2	2
3/4	1/2	4	11/32	1/2-13 UNC-2A	1 3/4	2 1/4
1	1/2	4	3/8	1/2-13 UNC-2A	1 3/4	2 1/4
1 1/4	1/2	4	13/32	1/2-13 UNC-2A	1 3/4	2 1/4
1 1/2	1/2	4	7/16	1/2-13 UNC-2A	1 3/4	2 1/4
2	5/8	4	1/2	5/8-11 UNC-2A	2	2 3/4
2 1/2	5/8	4	9/16	5/8-11 UNC-2A	2 1/4	2 3/4
3	5/8	4	5/8	5/8-11 UNC-2A	2 1/4	3
3 1/2	5/8	8	11/16	5/8-11 UNC-2A	2 1/2	3
4	5/8	8	11/16	5/8-11 UNC-2A	2 1/2	3
5	3/4	8	3/4	3/4-10 UNC-2A	2 3/4	3 1/2
6	3/4	8	13/16	3/4-10 UNC-2A	3	3 1/2
8	3/4	8	15/16	3/4-10 UNC-2A	3 1/4	3 3/4
10	7/8	12	1	7/8-9 UNC-2A	3 1/2	4 1/4
12	7/8	12	1 1/8	7/8-9 UNC-2A	3 1/2	4 1/4

^A 1 in. = 25.4 mm.

TABLE 9 Bolting Lengths for 300-lb Bronze Flanged Joints to ANSI B16.24 (see Fig. 1 and Fig. 2)

Nominal Pipe Size, in.	Bolt Diameter, in. ^A	Quantity per Joint	Flange Thickness, in. ^A	Bolt Stud Bolt Thread	Bolt Length Carbon Steel, in. ^A	Stud Bolt Length Carbon Steel, in. ^A
1/2	1/2	4	1/2	1/2-13 UNC-2A	2	2 1/2
3/4	5/8	4	17/32	5/8-11 UNC-2A	2 1/4	2 3/4
1	5/8	4	19/32	5/8-11 UNC-2A	2 1/4	3
1 1/4	5/8	4	5/8	5/8-11 UNC-2A	2 1/4	3
1 1/2	3/4	4	11/16	3/4-10 UNC-2A	2 1/2	3 1/4
2	5/8	8	3/4	5/8-11 UNC-2A	2 1/2	3 1/4
2 1/2	3/4	8	13/16	3/4-10 UNC-2A	3	3 1/2
3	3/4	8	29/32	3/4-10 UNC-2A	3	3 3/4
3 1/2	3/4	8	31/32	3/4-10 UNC-2A	3 1/4	4
4	3/4	8	1 1/16	3/4-10 UNC-2A	3 1/4	4
5	3/4	8	1 1/8	3/4-10 UNC-2A	3 1/2	4 1/4
6	3/4	12	1 3/16	3/4-10 UNC-2A	3 1/2	4 1/4
8	7/8	12	1 3/8	7/8-9 UNC-2A	4 1/4	5

^A 1 in. = 25.4 mm.

TABLE 10 Bolting Lengths for 150-lb Steel Flat Face to Bronze Flanged Joints to ANSI B16.5 and B16.24
(see Fig. 1 and Fig. 2)

Nominal Pipe Size, in.	Bolt Diameter, in. ^A	Quantity per Joint	Flange Thickness, in. ^A		Bolt Stud Bolt Thread	Bolt Length Carbon Steel, in. ^A	Stud Bolt Length Carbon Steel, in. ^A
			Steel	Bronze			
1/2	1/2	4	7/16	5/16	1/2-13 UNC-2A	1 3/4	2 1/4
3/4	1/2	4	1/2	11/32	1/2-13 UNC-2A	1 3/4	2 1/4
1	1/2	4	9/16	3/8	1/2-13 UNC-2A	1 3/4	2 1/4
1 1/4	1/2	4	5/8	13/32	1/2-13 UNC-2A	2	2 1/2
1 1/2	1/2	4	1 1/16	7/16	1/2-13 UNC-2A	2	2 1/2
2	5/8	4	3/4	1/2	5/8-11 UNC-2A	2 1/4	3
2 1/2	5/8	4	7/8	9/16	5/8-11 UNC-2A	2 1/2	3 1/4
3	5/8	4	1 5/16	5/8	5/8-11 UNC-2A	2 3/4	3 1/4
3 1/2	5/8	8	1 5/16	1 1/16	5/8-11 UNC-2A	2 3/4	3 1/4
4	5/8	8	1 5/16	1 1/16	5/8-11 UNC-2A	2 3/4	3 1/4
5	3/4	8	1 5/16	3/4	3/4-10 UNC-2A	3	3 3/4
6	3/4	8	1	13/16	3/4-10 UNC-2A	3	3 3/4
8	3/4	8	1 1/8	1 5/16	3/4-10 UNC-2A	3 1/4	4
10	7/8	12	1 3/16	1	7/8-9 UNC-2A	3 1/2	4 1/2
12	7/8	12	1 1/4	1 1/16	7/8-9 UNC-2A	3 3/4	4 1/2

^A 1 in. = 25.4 mm.

TABLE 11 Bolting Lengths for 300-lb Steel Flat Face to Bronze Flanged Joints to ANSI B16.5 and B16.24
(see Fig. 1 and Fig. 2)

Nominal Pipe Size, in.	Bolt Diameter, in. ^A	Quantity per Joint	Flange Thickness, in. ^A		Bolt Stud Bolt Thread	Bolt Length Carbon Steel, in. ^A	Stud Bolt Length Carbon Steel, in. ^A
			Steel	Bronze			
1/2	1/2	4	9/16	1/2	1/2-13 UNC-2A	2	2 1/2
3/4	5/8	4	5/8	17/32	5/8-11 UNC-2A	2 1/4	2 3/4
1	5/8	4	1 1/16	19/32	5/8-11 UNC-2A	2 1/4	3
1 1/4	5/8	4	3/4	5/8	5/8-11 UNC-2A	2 1/2	3
1 1/2	3/4	4	13/16	1 1/16	3/4-10 UNC-2A	2 3/4	3 1/2
2	5/8	8	7/8	3/4	5/8-11 UNC-2A	2 3/4	3 1/4
2 1/2	3/4	8	1	13/16	3/4-10 UNC-2A	3	3 3/4
3	3/4	8	1 1/8	29/32	3/4-10 UNC-2A	3 1/4	4
3 1/2	3/4	8	1 3/16	31/32	3/4-10 UNC-2A	3 1/2	4
4	3/4	8	1 1/4	1 1/16	3/4-10 UNC-2A	3 1/2	4 1/4
5	3/4	8	1 3/8	1 1/8	3/4-10 UNC-2A	3 3/4	4 1/2
6	3/4	12	1 7/16	1 3/16	3/4-10 UNC-2A	3 3/4	4 1/2
8	7/8	12	1 5/8	1 3/8	7/8-9 UNC-2A	4 1/2	5 1/4

^A 1 in. = 25.4 mm.

TABLE 12 Bolting Lengths for 125-lb Cast Iron to 150-lb Steel Flat Face Flanged Joints to MSS SP-44, ANSI B16.1, and ANSI B16.5
 (see Fig. 1 and Fig. 2)

Nominal Pipe Size, in.	Bolt Diameter, in. ^A	Quantity per Joint	Flange Thickness, in. ^A		Bolt Stud Bolt Thread	Bolt Length Carbon Steel, in. ^A	Stud Bolt Length Carbon Steel, in. ^A
			Cast Iron	Steel			
1	1/2	4	7/16	9/16	1/2-13 UNC-2A	2	2 1/2
1 1/4	1/2	4	1/2	5/8	1/2-13 UNC-2A	2	2 1/2
1 1/2	1/2	4	9/16	11/16	1/2-13 UNC-2A	2 1/4	2 3/4
2	5/8	4	5/8	3/4	5/8-11 UNC-2A	2 1/2	3
2 1/2	5/8	4	11/16	7/8	5/8-11 UNC-2A	2 3/4	3 1/4
3	5/8	4	3/4	15/16	5/8-11 UNC-2A	2 3/4	3 1/2
3 1/2	5/8	8	13/16	15/16	5/8-11 UNC-2A	3	3 1/2
4 through 24	<i>B</i>	<i>B</i>	<i>B</i>	<i>B</i>	<i>B</i>	<i>B</i>	<i>B</i>
30	1 1/4	28	2 1/8	2 15/16	1 1/4-7 UNC-2A	7	8 1/4
36	1 1/2	32	2 3/8	3 7/16	1 1/2-6 UNC-2A	8 1/4	9 1/2

^A 1 in. = 25.4 mm.

^B For dimensions of these pipe sizes, refer to Table 1.

TABLE 13 Bolting Lengths for 250-lb Cast Iron to 300-lb Steel Flat Face Flanged Joints to ANSI B16.1 and B16.5
 (see Fig. 1 and Fig. 2)

Nominal Pipe Size, in.	Bolt Diameter, in. ^A	Quantity per Joint	Flange Thickness, in. ^A	Bolt Stud Bolt Thread	Bolt Length Carbon Steel, in. ^A	Stud Bolt Length Carbon Steel, in. ^A
1 through 24	<i>B</i>	<i>B</i>	<i>B</i>	<i>B</i>	<i>B</i>	<i>B</i>

^A 1 in. = 25.4 mm.

^B For dimensions on these pipe sizes, refer to Table 2.

TABLE 14 Bolting Lengths for 800-lb Cast Iron to 600-lb Steel Flanged Joints to ANSI B16.1 and B16.5
 (see Fig. 3 and Fig. 4)

Nominal Pipe Size, in. ^v	Bolt Diameter, in. ^A	Quantity per Joint	Flange Thickness, in. ^A		Bolt Stud Bolt Thread	Bolt Length Alloy Steel, in. ^A	Stud Bolt Length Alloy Steel, in. ^A
			Steel	Bronze			
2	5/8	8	1 1/2	1	5/8-11 UNC-2A	not used	4 1/2
2 1/2	3/4	8	1 5/8	1 1/8	3/4-10 UNC-2A	not used	5
3	3/4	8	1 3/4	1 1/4	3/4-10 UNC-2A	not used	5 1/4
3 1/2	7/8	8	1 7/8	1 3/8	7/8-9 UNC-2A	not used	5 3/4
4	7/8	8	2 1/8	1 1/2	7/8-9 UNC-2A	not used	6
5	1	8	2 3/8	1 3/4	1-8 UNC-2A	not used	6 3/4
6	1	12	2 1/2	1 7/8	1-8 UNC-2A	not used	7
8	1 1/8	12	2 3/4	2 3/16	1 1/8-8 UN-2A	not used	8
10	1 1/4	16	3 1/8	2 1/2	1 1/4-8 UN-2A	not used	8 3/4
12	1 1/4	20	3 1/4	2 5/8	1 1/4-8 UN-2A	not used	9

^A 1 in. = 25.4 mm.



TABLE 15 Bolting Lengths for Wafer-Type Butterfly Valve and 150-lb Steel Flanges to ANSI B16.5
(see Fig. 5 and Fig. 6)

Nominal Pipe Size, in.	Bolt Diameter, in. ^A	Quantity per Assembly	Flange Thickness, in. ^A	Valve Face to Face Dimension, max, in. ^A	Bolt Stud Bolt Thread	Bolt Length Carbon Steel, in. ^A	Stud Bolt Length Carbon Steel, in. ^A
2	5/8	4	3/4	1 3/4	5/8-11 UNC-2A	4 1/4	4 3/4
2 1/2	5/8	4	7/8	1 7/8	5/8-11 UNC-2A	4 3/4	5 1/4
3	5/8	4	1 5/16	1 7/8	5/8-11 UNC-2A	4 3/4	5 1/4
3 1/2	5/8	8	1 5/16	1 5/16	5/8-11 UNC-2A	4 3/4	5 1/2
4	5/8	8	1 5/16	2 3/16	5/8-11 UNC-2A	5	5 3/4
5	3/4	8	1 5/16	2 3/16	3/4-10 UNC-2A	5 1/4	6
6	3/4	8	1	2 3/16	3/4-10 UNC-2A	5 1/4	6
8	3/4	8	1 1/8	2 9/16	3/4-10 UNC-2A	6	6 3/4
10	7/8	12	1 3/16	2 13/16	7/8-9 UNC-2A	6 1/2	7 1/4
12	7/8	12	1 1/4	3 5/16	7/8-9 UNC-2A	7 1/4	8
14	1	12	1 3/8	3 5/8	1-8 UNC-2A	7 3/4	8 3/4
16	1	16	1 7/16	4 1/8	1-8 UNC-2A	8 1/2	9 1/4
18	1 1/8	16	1 9/16	4 5/8	1 1/8-7 UNC-2A	9 1/2	10 1/4
20	1 1/8	20	1 11/16	5 1/8	1 1/8-7 UNC-2A	10 1/4	11 1/4
24	1 1/4	20	1 7/8	6 3/16	1 1/4-7 UNC-2A	11 3/4	13
30	1 1/4	28	2 15/16	7 5/8	1 1/4-7 UNC-2A	15 1/4	16 1/2

^A 1 in. = 25.4 mm.

TABLE 16 Bolting Lengths for Wafer-Type Butterfly Valve and 150-lb Bronze Flanges to ANSI B16.24
(see Fig. 5 and Fig. 6)

Nominal Pipe Size, in.	Bolt Diameter, in. ^A	Quantity per Assembly	Flange Thickness, in. ^A	Valve Face to Face Dimension, in. ^A	Bolt Stud Bolt Thread	Bolt Length Carbon Steel, in. ^A	Stud Bolt Length Carbon Steel, in. ^A
2	5/8	4	1/2	1 3/4	5/8-11 UNC-2A	3 3/4	4 1/4
2 1/2	5/8	4	9/16	1 7/8	5/8-11 UNC-2A	4	4 1/2
3	5/8	4	5/8	1 7/8	5/8-11 UNC-2A	4 1/4	4 3/4
3 1/2	5/8	8	1 1/16	1 5/16	5/8-11 UNC-2A	4 1/4	5
4	5/8	8	1 1/16	2 3/16	5/8-11 UNC-2A	4 1/2	5 1/4
5	3/4	8	3/4	2 3/16	3/4-10 UNC-2A	4 3/4	5 1/2
6	3/4	8	13/16	2 3/16	3/4-10 UNC-2A	5	5 3/4
8	3/4	8	1 5/16	2 9/16	3/4-10 UNC-2A	5 1/2	6 1/4
10	7/8	12	1	2 13/16	7/8-9 UNC-2A	6 1/4	7
12	7/8	12	1 1/16	3 5/16	7/8-9 UNC-2A	6 3/4	7 1/2

^A 1 in. = 25.4 mm.

TABLE 17 Bolting Lengths for Tapped Lug-Type Butterfly Valve and 150-lb Steel Flanges to ANSI B16.5 (see Fig. 7)

Nominal Pipe Size, in.	Bolt Diameter, in. ^A	Quantity per Assembly	Flange Thickness, in. ^A	Valve Face to Face Dimension, min, in. ^A	Bolt Thread	Bolt Length Carbon Steel, in. ^A
2	5/8	8	3/4	1 3/16	5/8-11 UNC-2A	1 1/2
2 1/2	5/8	8	7/8	1 3/4	5/8-11 UNC-2A	1 1/2
3	5/8	8	1 5/16	1 3/4	5/8-11 UNC-2A	1 3/4
3 1/2	5/8	16	1 5/16	1 15/16	5/8-11 UNC-2A	1 3/4
4	5/8	16	1 5/16	1 7/8	5/8-11 UNC-2A	1 3/4
5	3/4	16	1 5/16	2 1/16	3/4-10 UNC-2A	1 3/4
6	3/4	16	1	2 1/16	3/4-10 UNC-2A	1 3/4
8	3/4	16	1 1/8	2 3/8	3/4-10 UNC-2A	2 1/4
10	7/8	24	1 3/16	2 1/2	7/8-9 UNC-2A	2 1/4
12	7/8	24	1 1/4	3	7/8-9 UNC-2A	2 1/2
14	1	24	1 3/8	3	1-8 UNC-2A	2 3/4
16	1	32	1 7/16	3 3/8	1-8 UNC-2A	3
18	1 1/8	32	1 9/16	4	1 1/8-7 UNC-2A	3 1/4
20	1 1/8	40	1 11/16	4 1/2	1 1/8-7 UNC-2A	3 1/2
24	1 1/4	40	1 7/8	5 7/8	1 1/4-7 UNC-2A	3 3/4
30	1 1/4	56	2 15/16	6 1/2	1 1/4-7 UNC-2A	5

^A 1 in. = 25.4 mm.

TABLE 18 Bolting Length for Tapped Lug-Type Butterfly Valve and 150-lb Bronze Flanges to ANSI B16.24 (see Fig. 7)

Nominal Pipe Size, in.	Bolt Diameter, in. ^A	Quantity per Assembly	Flange Thickness, in. ^A	Valve Face to Face Dimension, min, in. ^A	Bolt Thread	Bolt Length Carbon Steel, in. ^A
2	5/8	8	1/2	1 9/16	5/8-11 UNC-2A	1 1/4
2 1/2	5/8	8	9/16	1 3/4	5/8-11 UNC-2A	1 1/4
3	5/8	8	5/8	1 3/4	5/8-11 UNC-2A	1 1/4
3 1/2	5/8	16	1 1/16	1 15/16	5/8-11 UNC-2A	1 1/2
4	5/8	16	1 1/16	1 7/8	5/8-11 UNC-2A	1 1/2
5	3/4	16	3/4	2 1/16	3/4-10 UNC-2A	1 3/4
6	3/4	16	13/16	2 1/16	3/4-10 UNC-2A	1 3/4
8	3/4	16	1 5/16	2 3/8	3/4-10 UNC-2A	2
10	7/8	24	1	2 1/2	7/8-9 UNC-2A	2
12	7/8	24	1 1/16	3	7/8-9 UNC-2A	2 1/2

^A 1 in. = 25.4 mm.

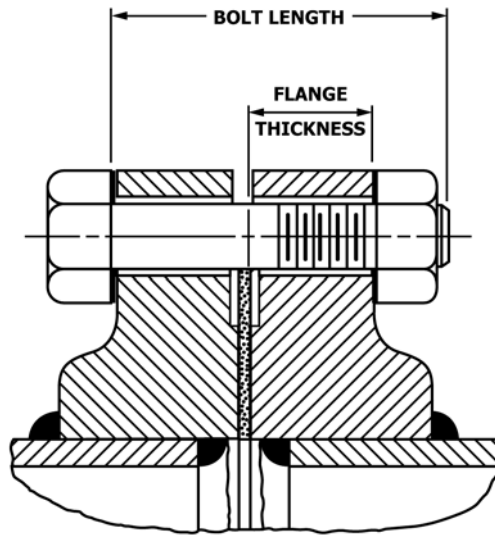

NOTE 1—Raised face shown, flat face similar.

FIG. 1 Flange Bolt Assembly for 125- to 300-psi Flanges

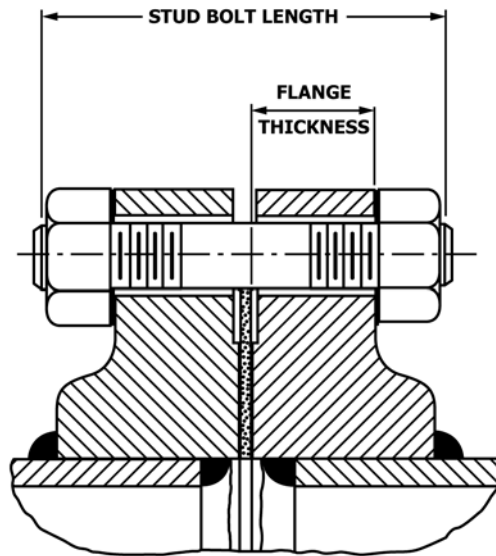

FIG. 2 Flange Stud Bolt Assembly for 125- to 300-psi Flanges

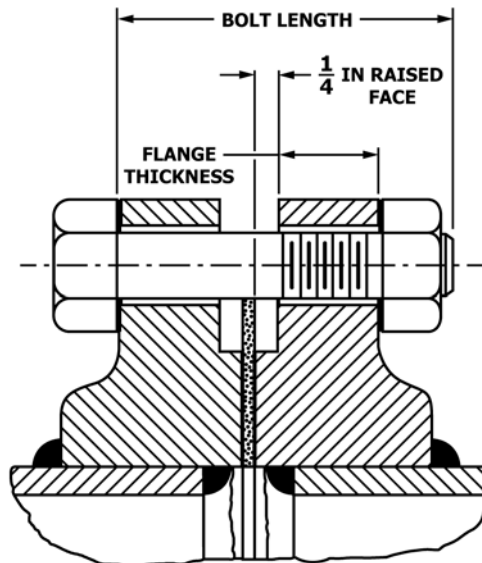

FIG. 3 Flange Bolt Assembly for 400-psi and Above Flanges

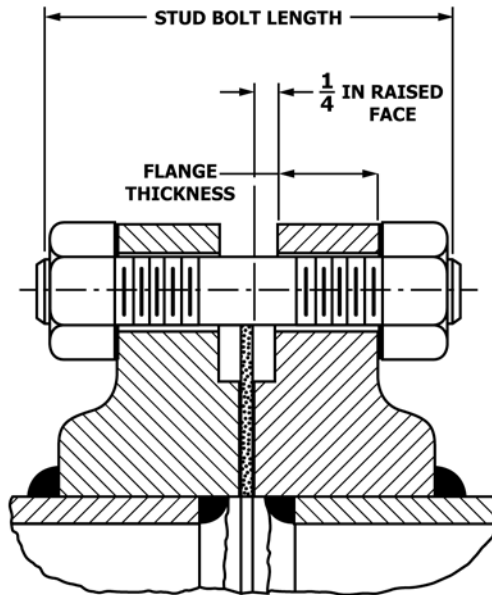

FIG. 4 Flange Stud Bolt Assembly for 400-psi and Above Flanges

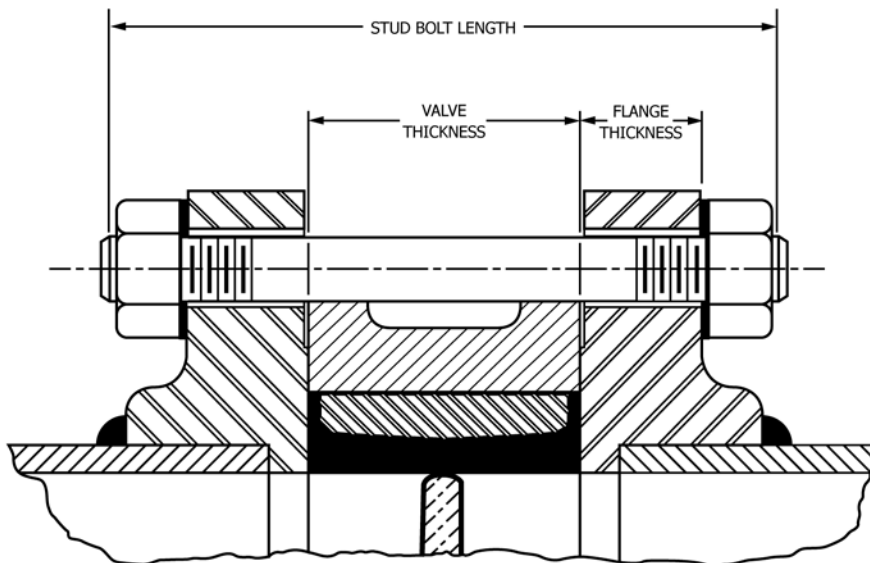

FIG. 5 Butterfly Valve Stud Bolt Assembly with 150-psi Steel or Bronze Flanges

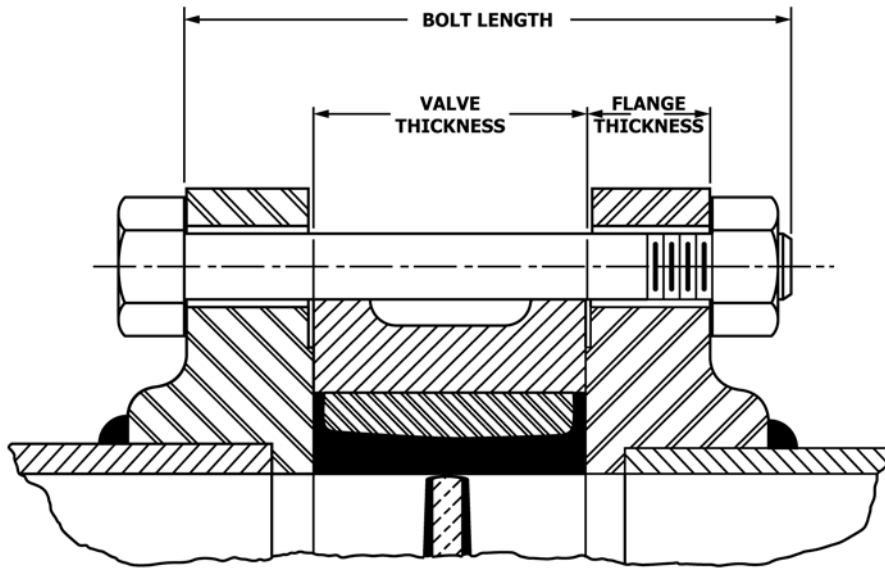

FIG. 6 Butterfly Valve Bolt Assembly with 150-psi Steel or Bronze Flanges

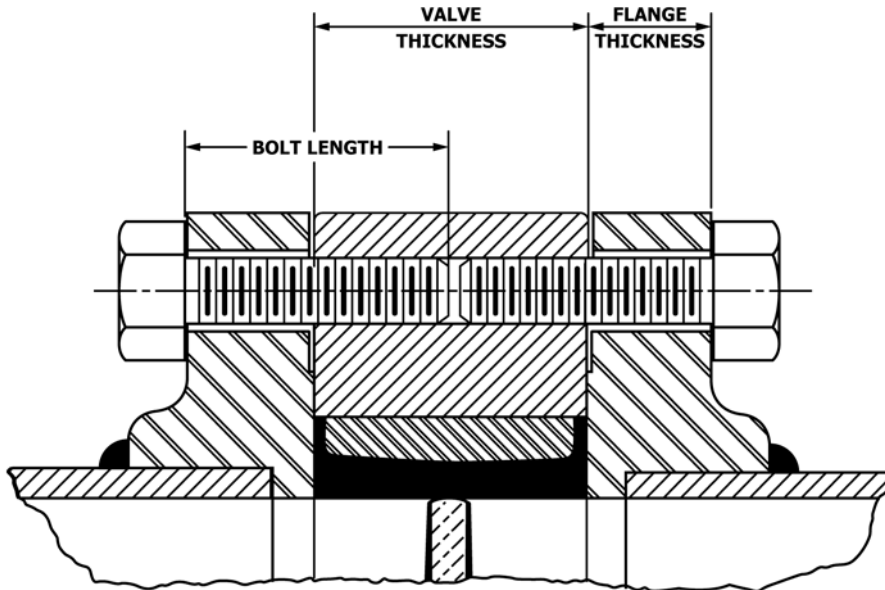

FIG. 7 Tapped Lug-Type Butterfly Valve Bolt Assembly with 150-psi Steel or Bronze Flanges

ANNEX

(Mandatory Information)

A1. METHOD FOR CALCULATING BOLTING LENGTHS

A1.1 The following equations were used in determining bolt and stud bolt lengths in **Tables 1-16** and are included in this annex for computing bolting lengths not shown in these tables.

A1.1.1 Bolting lengths for flange to flange joints are computed using the following equation:

$$L_{SB} = 2T + 2N + G + 2t + 2F + n \quad (A1.1)$$

$$L_{MB} = 2T + N + G + 2t + 2F + n \quad (A1.2)$$

where:

- L_{SB} = length of stud bolt (effective thread length excluding point height),
- L_{MB} = length of machine bolt as measured from under side of head to first thread,

- T = minimum flange thickness,
 t = plus tolerance for flange thickness in accordance with ANSI B16.5,
 N = maximum height of nut (heavy hex) in accordance with ANSI B18.2.2,
 G = 1/8-in. gasket thickness (maximum),
 F = height of raised face where not included in flange thickness, and
 n = negative bolting length tolerance in accordance with ANSI B18.2.1.

A1.1.2 Bolting lengths for wafer-type butterfly valves (commercial grade) installed between pipe flanges are computed using the following equations:

$$L_{MB} = 2T + N + V + 2t + n \quad (A1.3)$$

$$L_{SB} = 2T + 2N + V + 2t + n \quad (A1.4)$$

where:

- L_{MB} = length of machine bolt as measured from underside of head to first thread,
 L_{SB} = length of stud bolt excluding point height,
 T = minimum flange thickness,
 t = plus tolerance for flange thickness in accordance with ANSI B16.5,
 N = maximum height of nut (heavy hex) in accordance with ANSI B18.2.2,

- V = thickness of butterfly valve, and
 n = negative stud bolt length tolerance in accordance with ANSI B16.5.

A1.1.3 Bolt lengths for tapped lug-type butterfly valves (commercial grade) installed between pipe flanges are computed using the following equation:

$$L_{MB} = T + V/2 \quad (A1.5)$$

where:

- L_{MB} = length of machine bolt as measured from underside of head to first thread,
 T = minimum flange thickness, and
 V = thickness of butterfly valve.

NOTE A1.1—Rounding-off bolt or stud bolt length to 1/4-in. (6.3-mm) increments: where L_{SB} or L_{MB} is 0.10 in. or more greater than any 1/4-in. increment, round off upward; if less than 0.10 in., round off downward to next 1/4-in. increment. L_{MB} for tapped lug-type butterfly valve, round off downward to next 1/4-in. increment.

NOTE A1.2—Users are reminded that removing the raised face will make the flange thickness dimension nonstandard.

NOTE A1.3—Stud bolt lengths listed in Table 15 and Table 16 are sized to accommodate maximum width of all commercial grade wafer-type butterfly valves of up to 150-psi pressure rating.

NOTE A1.4—Bolt lengths listed in Table 17 and Table 18 are sized to accommodate minimum width of all commercial grade tapped lug-type butterfly valves of up to 150-psi pressure ratings.

ASTM International takes no position respecting the validity of any patent rights asserted in connection with any item mentioned in this standard. Users of this standard are expressly advised that determination of the validity of any such patent rights, and the risk of infringement of such rights, are entirely their own responsibility.

This standard is subject to revision at any time by the responsible technical committee and must be reviewed every five years and if not revised, either reapproved or withdrawn. Your comments are invited either for revision of this standard or for additional standards and should be addressed to ASTM International Headquarters. Your comments will receive careful consideration at a meeting of the responsible technical committee, which you may attend. If you feel that your comments have not received a fair hearing you should make your views known to the ASTM Committee on Standards, at the address shown below.

This standard is copyrighted by ASTM International, 100 Barr Harbor Drive, PO Box C700, West Conshohocken, PA 19428-2959, United States. Individual reprints (single or multiple copies) of this standard may be obtained by contacting ASTM at the above address or at 610-832-9585 (phone), 610-832-9555 (fax), or service@astm.org (e-mail); or through the ASTM website (www.astm.org). Permission rights to photocopy the standard may also be secured from the Copyright Clearance Center, 222 Rosewood Drive, Danvers, MA 01923, Tel: (978) 646-2600; http://www.copyright.com/