



## Standard Test Method for Measuring Unsaturated TTL Sink Current<sup>1</sup>

This standard is issued under the fixed designation F 676; the number immediately following the designation indicates the year of original adoption or, in the case of revision, the year of last revision. A number in parentheses indicates the year of last reapproval. A superscript epsilon ( $\epsilon$ ) indicates an editorial change since the last revision or reapproval.

### 1. Scope

1.1 This test method covers the measurement of the unsaturated sink current of transistor-transistor logic (TTL) devices under specified conditions.

1.2 *Units*—The values stated in the International System of Units (SI) are to be regarded as standard. No other units of measurement are included in this standard.

1.3 *This standard does not purport to address all of the safety concerns, if any, associated with its use. It is the responsibility of the user of this standard to establish appropriate safety and health practices and determine the applicability of regulatory limitations prior to use.*

### 2. Referenced Documents

2.1 *ASTM Standards:*

E 178 Practice for Dealing with Outlying Observations<sup>2</sup>

### 3. Summary of Test Method

3.1 Input and bias voltage levels and any required input signals are applied to the device under test to put the output to be tested in the low-level state. Voltage pulses of sufficient magnitude to pull the output transistor out of saturation are applied to the output pin under test. The corresponding current pulses are measured.

3.2 The following test conditions are not specified by the test method and shall be agreed upon by the parties to the test:

3.2.1 The output pin(s) to be tested,

3.2.2 Ambient temperature range,

3.2.3 Supply voltage(s) to be used,

3.2.4 Input sequence to be applied before the device output is pulsed,

3.2.5 Pulse voltage to be applied to the output pin under test,

3.2.6 Duty cycle and duration of the applied pulses, and

3.2.7 Accuracy and tolerances required for supply voltage(s), input voltages, pulse voltage, current measurement, duty cycle, and pulse-width.

### 4. Significance and Use

4.1 Unsaturated sink current is a special parameter that is closely related to the gain of the output transistor of TTL circuits. This parameter is particularly useful in evaluating neutron degradation in TTL devices because it changes smoothly as the device degrades, and exhibits larger changes at moderate radiation levels than the standard electrical parameters.

### 5. Interferences

5.1 Long pulses will cause many current probes to saturate. The current-time rating of the probe must not be exceeded.

5.2 Valid measurements will not be obtained unless the voltage applied to the output is sufficient to bring the output transistor out of saturation.

5.3 If the voltage applied to the output exceeds 1.5 V, errors may result. Some devices may change state. Some devices have internal diode connections which will conduct if the output exceeds 1.5 V.

5.4 High contact resistance will cause the voltage at the device to differ from the applied voltage. Kelvin contacts may be required.

5.5 Device temperature will affect this measurement. Pulse width and duty cycle must be maintained low enough that the test does not cause heating of the device.

### 6. Apparatus

6.1 *Pulse Generator*, capable of supplying the current required by the output pin under test at the agreed-upon voltage.

6.2 *Oscilloscope, or Digital Recorder*, dual-beam or dual-trace, meeting the following requirements:

6.2.1 Bandwidth of 30 MHz or greater.

6.2.2 Deflection factor range of 5 mV per division to 1 V per division.

6.3 *Termination  $R_T$* , suitable for the current probe used.

6.4 *Current Probe*, meeting the following requirements:

6.4.1 Rise time less than 10 % of the agreed-upon pulse width.

6.4.2 Droop no more than 5 % of the agreed-upon pulse width.

<sup>1</sup> This test method is under the jurisdiction of ASTM Committee F01 on Electronics and is the direct responsibility of Subcommittee F01.11 on Quality and Hardness Assurance.

Current edition approved Dec. 10, 1997. Published March 1998. Originally published as F 676 – 80. Last previous edition F 676 – 93.

<sup>2</sup> 1983 Annual Book of ASTM Standards, Vol 14.02.

6.4.3 Current-time rating sufficient to avoid saturation. See 4.1.

6.5 *Power Supplies and Pulse Generators*, as required to establish bias and input conditions for the test.

6.6 *Oscilloscope Probe*, having an input impedance of 1 MΩ or greater in parallel with 25 pF or less.

6.7 *Miscellaneous Circuit Components*, to be used as required to set up the test circuit. See Fig. 1. All components shall be of a quality customarily used in electronic circuit fabrication.

6.8 *Temperature-Measuring Device*, capable of measuring the temperature in the vicinity of the device under test to an accuracy of  $\pm 1^\circ\text{C}$  at the temperature specified for the measurement.

## 7. Sampling

7.1 This test method determines the properties of a single specimen. If sampling procedures are used to select devices for test, the procedures shall be agreed upon by the parties to the test.

## 8. Procedure

8.1 Assemble the circuit shown in Fig. 1. Leave the output pin pulse generator disconnected. Connect the 0.1-μF capacitor as close as possible to device socket.

8.2 Turn on all electronic equipment and allow to warm up for a minimum of 5 min or as required by the manufacturer.

8.3 Adjust power supply and pulse generator outputs to zero volts.

8.4 Insert the device to be tested in the test socket.

8.5 Adjust the specified power supply voltages and perform the specified input sequence.

8.6 Record ambient temperature in the vicinity of the device under test.

8.7 Adjust the output pin pulse generator duty cycle and pulse width to their agreed-upon values and reset to zero.

8.8 Connect the output pin pulse generator to the test circuit and slowly increase the amplitude of the output pin pulse generator until the agreed-upon voltage pulse is obtained.

8.9 Adjust the oscilloscope gain controls so that both the current and voltage signals are at least 3 divisions in amplitude.

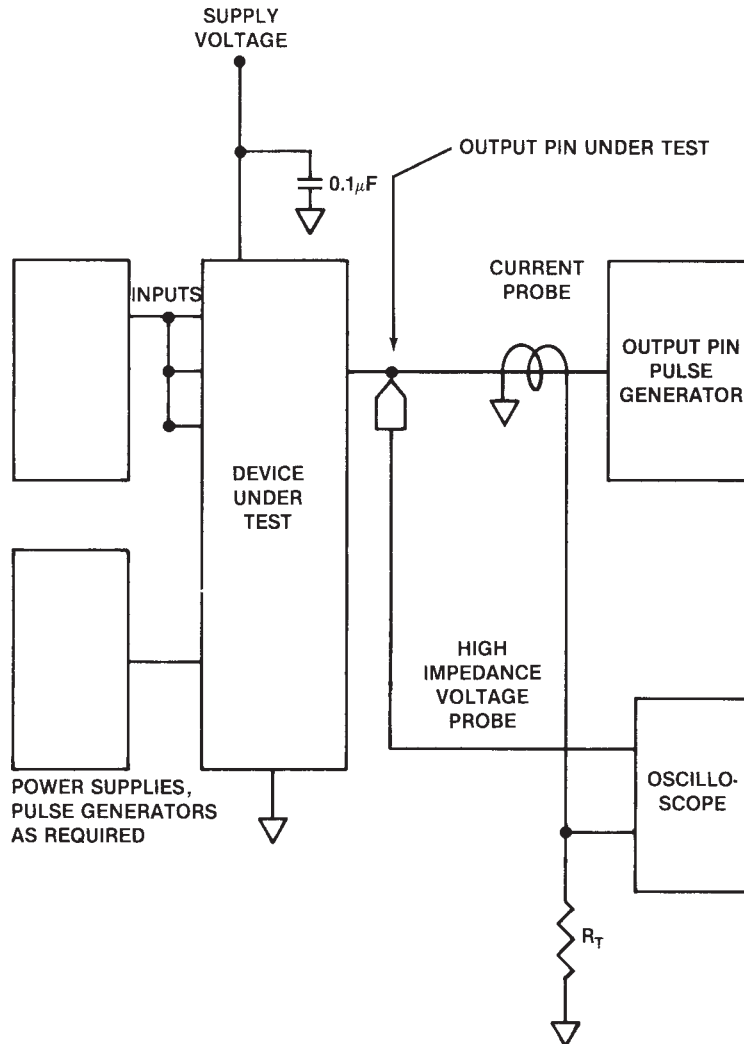

FIG. 1 Test Circuit for Sink Current Measurement

Read and record the amplitude of the current and voltage pulses from the oscilloscope displays.

## 9. Report

9.1 The report shall contain as a minimum:

- 9.1.1 Identification of operator,
- 9.1.2 Date of test,
- 9.1.3 Type and identification of the device under test, including date code, vendor, and package type,
- 9.1.4 Value of power supply voltage(s) used,
- 9.1.5 Duty cycle and pulse width,
- 9.1.6 Current probe type (model and manufacturer),
- 9.1.7 Ambient temperature,

- 9.1.8 Pin tested,
- 9.1.9 Input test sequence, and
- 9.1.10 Pulse amplitude used and corresponding current measured.

## 10. Precision and Bias

10.1 An interlaboratory test of the method was conducted among six laboratories, each with five devices from a total of five different device types.

10.2 The  $T_n$  criteria for single samples of Practice E 178, was applied to the datum from one laboratory for one device. The value reported for this device failed the criterion for significance at the level of 5 %. On this basis, the datum was deleted from the analysis of the test.

10.3 The analysis of the remaining data involved the calculation of the mean values and percent standard deviations of the unsaturated sink currents reported. The average of the percent standard deviations of the currents reported by the participating laboratories for all (25) devices was found to be 2.55 % with a standard deviation of 0.68 %. The results of other calculations are summarized in Table 1.

## 11. Keywords

11.1 hardness assurance; neutron degradation; sink current; transistor-transistor logic (TTL)

**TABLE 1 Precision and Bias Data**

Device Type	Range of Device Current Means, mA	Interlaboratory Range of Percent Standard Deviation of Current Means, %	Average Standard Deviation, %
SN7400J	52.4 to 66.8	2.70 to 3.30	2.97
DM74L00N	7.41 to 8.66	1.72 to 3.04	2.56
F74H00DC	47.7 to 153	1.29 to 3.61	2.30
DM74L03N	9.42 to 10.7	1.59 to 2.11	1.84
74S03/9S03DC	89.0 to 103	2.82 to 3.45	3.10

*ASTM International takes no position respecting the validity of any patent rights asserted in connection with any item mentioned in this standard. Users of this standard are expressly advised that determination of the validity of any such patent rights, and the risk of infringement of such rights, are entirely their own responsibility.*

*This standard is subject to revision at any time by the responsible technical committee and must be reviewed every five years and if not revised, either reapproved or withdrawn. Your comments are invited either for revision of this standard or for additional standards and should be addressed to ASTM International Headquarters. Your comments will receive careful consideration at a meeting of the responsible technical committee, which you may attend. If you feel that your comments have not received a fair hearing you should make your views known to the ASTM Committee on Standards, at the address shown below.*

*This standard is copyrighted by ASTM International, 100 Barr Harbor Drive, PO Box C700, West Conshohocken, PA 19428-2959, United States. Individual reprints (single or multiple copies) of this standard may be obtained by contacting ASTM at the above address or at 610-832-9585 (phone), 610-832-9555 (fax), or service@astm.org (e-mail); or through the ASTM website (www.astm.org).*