



Standard Test Method for Evaluation of Carpet Embedded Dirt Removal Effectiveness of Household/Commercial Vacuum Cleaners¹

This standard is issued under the fixed designation F608; the number immediately following the designation indicates the year of original adoption or, in the case of revision, the year of last revision. A number in parentheses indicates the year of last reapproval. A superscript epsilon (ϵ) indicates an editorial change since the last revision or reapproval.

1. Scope

1.1 This test method covers only a laboratory test for determining the relative carpet dirt removal effectiveness of household/commercial vacuum cleaners when tested under specified conditions.

1.2 This test method is applicable to household/commercial types of upright, canister, and combination cleaners.

1.3 The test method applies to embedded dirt removal from carpets, not the removal of surface litter and debris.

1.4 The values stated in inch-pound units are to be regarded as standard. The values given in parentheses are mathematical conversions to SI units that are provided for information only and are not considered standard.

1.5 *This standard does not purport to address all of the safety concerns, if any, associated with its use. It is the responsibility of the user of this standard to establish appropriate safety and health practices and determine the applicability of regulatory limitations prior to use.*

2. Referenced Documents

2.1 *ASTM Standards:*²

[C136/C136M Test Method for Sieve Analysis of Fine and Coarse Aggregates](#)

[E11 Specification for Woven Wire Test Sieve Cloth and Test Sieves](#)

[E177 Practice for Use of the Terms Precision and Bias in ASTM Test Methods](#)

[E691 Practice for Conducting an Interlaboratory Study to Determine the Precision of a Test Method](#)

[F655 Specification for Test Carpets and Pads for Vacuum Cleaner Testing](#)

[F884 Test Method for Motor Life Evaluation of a Built-In](#)

[\(Central Vacuum\) Vacuum Cleaner](#)

[F922 Test Method for Motor Life Evaluation of an Electric Motorized Nozzle](#)

[F1038 Test Method for Motor Life Evaluation of a Canister, Hand-held, Stick, and Utility Type Vacuum Cleaner Without a Driven Agitator](#)

[F1334 Test Method for Determining A-Weighted Sound Power Level of Vacuum Cleaners](#)

[F1409 Test Method for Straight Line Movement of Vacuum Cleaners While Cleaning Carpets](#)

[F2608 Test Method for Determining the Change in Room Air Particulate Counts as a Result of the Vacuum Cleaning Process](#)

[F2756 Test Method for Determining Energy Consumption of Vacuum Cleaners](#)

3. Terminology

3.1 *Definitions:*

3.1.1 *model, n*—the designation of a group of vacuum cleaners having identical mechanical and electrical construction with only cosmetic or nonfunctional differences.

3.1.2 *population, n*—the total of all units of a particular model vacuum cleaner being tested.

3.1.3 *repeatability limit, r*—the value below which the absolute difference between two individual test results obtained under repeatability condition may be expected to occur with a probability of approximately 0.95 (95 %).

3.1.4 *repeatability standard deviation, S_r* —the standard deviation of test results obtained under repeatability conditions.

3.1.5 *reproducibility limit, R*—the value below which the absolute difference between two test results obtained under reproducibility conditions may be expected to occur with a probability of approximately 0.95 (95 %).

3.1.6 *reproducibility standard deviation, S_R* —the standard deviation of test results obtained under reproducibility conditions.

3.1.7 *sample, n*—a group of vacuum cleaners taken from a large collection of vacuum cleaners of one particular model which serves to provide information that may be used as a basis for making a decision concerning the larger collection.

¹ This test method is under the jurisdiction of ASTM Committee F11 on Vacuum Cleaners and is the direct responsibility of Subcommittee F11.21 on Cleanability. Current edition approved March 1, 2017. Published March 2017. Originally approved in 1979. Last previous edition approved in 2013 as F608 – 13. DOI: 10.1520/F0608-17.

² For referenced ASTM standards, visit the ASTM website, www.astm.org, or contact ASTM Customer Service at service@astm.org. For *Annual Book of ASTM Standards* volume information, refer to the standard's Document Summary page on the ASTM website.

3.1.8 *test run, n*—the definitive procedure that produces a singular measured result.

3.1.9 *unit, n*—a single vacuum cleaner of the model being tested.

4. Significance and Use

4.1 This test method provides an indication of the capability of the vacuum cleaner to remove embedded dirt from carpeting. This test method is based upon results of home cleaning tests so that, in most cases, a reasonable correlation exists between home and laboratory results. The amount of dirt picked up in the laboratory test may not be the same as in the home; however, it will show that, in most cases, a vacuum cleaner that performs well in the laboratory will perform well in a home. Laboratory results may differ due to variations in the homes, carpets, dirt, and other factors (see Section 6).

4.2 In order to provide a uniform basis for measuring the performance described in 1.1, standardized test carpets and a standardized test dirt are employed in this procedure.

5. Apparatus

5.1 *Weighing Scale for Weighing Carpets*, accurate to 0.035 oz (1 g) and having a weighing capacity of at least 15 lb (6.82 kg).

5.2 *Weighing Scale (for Weighing Test Dirt and Dirt Container)*, (see 9.2.2.1(2)), accurate to 0.0035 oz (0.1 g) and having a weighing capacity of at least 1.1 lb (500 g).³

5.3 *Stopwatch*, with a second hand or other type of equipment capable of establishing the specified rate of movement and total cycle time.

5.4 *Voltmeter*, to measure input volts to the vacuum cleaner, to provide measurements accurate to within $\pm 1\%$.

5.5 *Voltage-Regulator System*, to control the input voltage to the vacuum cleaner. The regulator shall be capable of maintaining the vacuum cleaner's rated voltage $\pm 1\%$ and rated frequency having a wave form that is essentially sinusoidal with 3 % maximum harmonic distortion for the duration of the test.

5.6 *Dirt Embedment Tool*, with the roller locked (see Fig. 3).

5.7 *Dirt Dispenser*—Dispensing system that provides the operator with a method to distribute the test dirt *uniformly* on the carpet test area.

5.8 *Carpet-Conditioning Equipment*, to support the test carpet during new carpet conditioning and the removal of residual dirt from the test carpet before each test run (Fig. 4).

5.9 *Rotating Agitator Conditioning Vacuum Cleaner/Equipment*, for conditioning new test carpets and removing

residual dirt from the test carpet before each test run. This cannot be the unit being tested.

NOTE 1—Automated methods for spreading the test dirt, embedding the test dirt, and cleaning and reconditioning the test carpets are acceptable if they do not change the results of this test method.

5.10 *Temperature and Humidity Indicators*, to provide temperature measurements accurate to within $\pm 1^\circ\text{F}$ ($\pm 1/2^\circ\text{C}$) and humidity measurements accurate to within 2 % relative humidity.

5.11 *Supporting Surface*—A flat surface consisting of a piece of $3/4$ -in. (19-mm) thick exterior grade plywood with the “A” surface upward to support the test carpet and pad. If necessary, the four corners (only) of the test carpet and pad may be fastened to the supporting surface by any acceptable means.

5.12 *Rotating Agitator Reference Vacuum Cleaner*, one, for calibrating test carpets (see 9.3).

5.13 *Straight-Air Canister Reference Vacuum Cleaner*, one, for calibrating test carpets (see 9.3).

6. Materials

6.1 Standard carpets conforming to Specification F655,

6.2 Standard carpet padding conforming to Specification F655,

6.3 Test dirt (see Annex A1),

6.3.1 Silica sand (see Annex A1), and

6.3.2 Talc (see Annex A1).

6.4 All products being tested in a comparison test must be tested using materials from identical production lots or batches. Verify that a sufficient quantity of all materials from a single lot/batch is on hand prior to starting the test program.

7. Sampling

7.1 A minimum of three units of the same model vacuum cleaner selected at random in accordance with good statistical practice shall constitute the population sample.

7.1.1 To determine the best estimate of cleaning ability effectiveness for the population of the vacuum cleaner model being tested, the arithmetic mean of the cleaning ability rating of the sample from the population shall be established by testing it to a 90 % confidence level within $\pm 5\%$ of the mean value of the cleaning ability rating.

7.1.2 Annex A3 provides a procedural example for determining the 90 % confidence level and when the sample size shall be increased.

NOTE 2—See Annex A3 for method of determining 90 % confidence level for both individual carpets and geometric mean.

8. Conditioning

8.1 *Test Room*—Maintain the test room in which all conditioning and vacuum cleaner testing is performed at $70 \pm 5^\circ\text{F}$ ($21 \pm 3^\circ\text{C}$) and 45 to 55 % relative humidity.

8.2 All components involved in the test shall remain and be exposed in the controlled environment for at least 16 h prior to the start of the test.

³ The Mettler-Toledo Model PM 2000, available from Mettler-Toledo, Inc. Box 71, Hightstown, NJ 08520, the OHAUS Model GT-8000 available from OHAUS, Inc. Florham Park, NJ, or equivalent, have been found suitable for this purpose. (It is recommended that the scale read directly in grams.) If you are aware of alternative suppliers, please provide this information to ASTM International Headquarters. Your comments will receive careful consideration at a meeting of the responsible technical committee,¹ which you may attend.

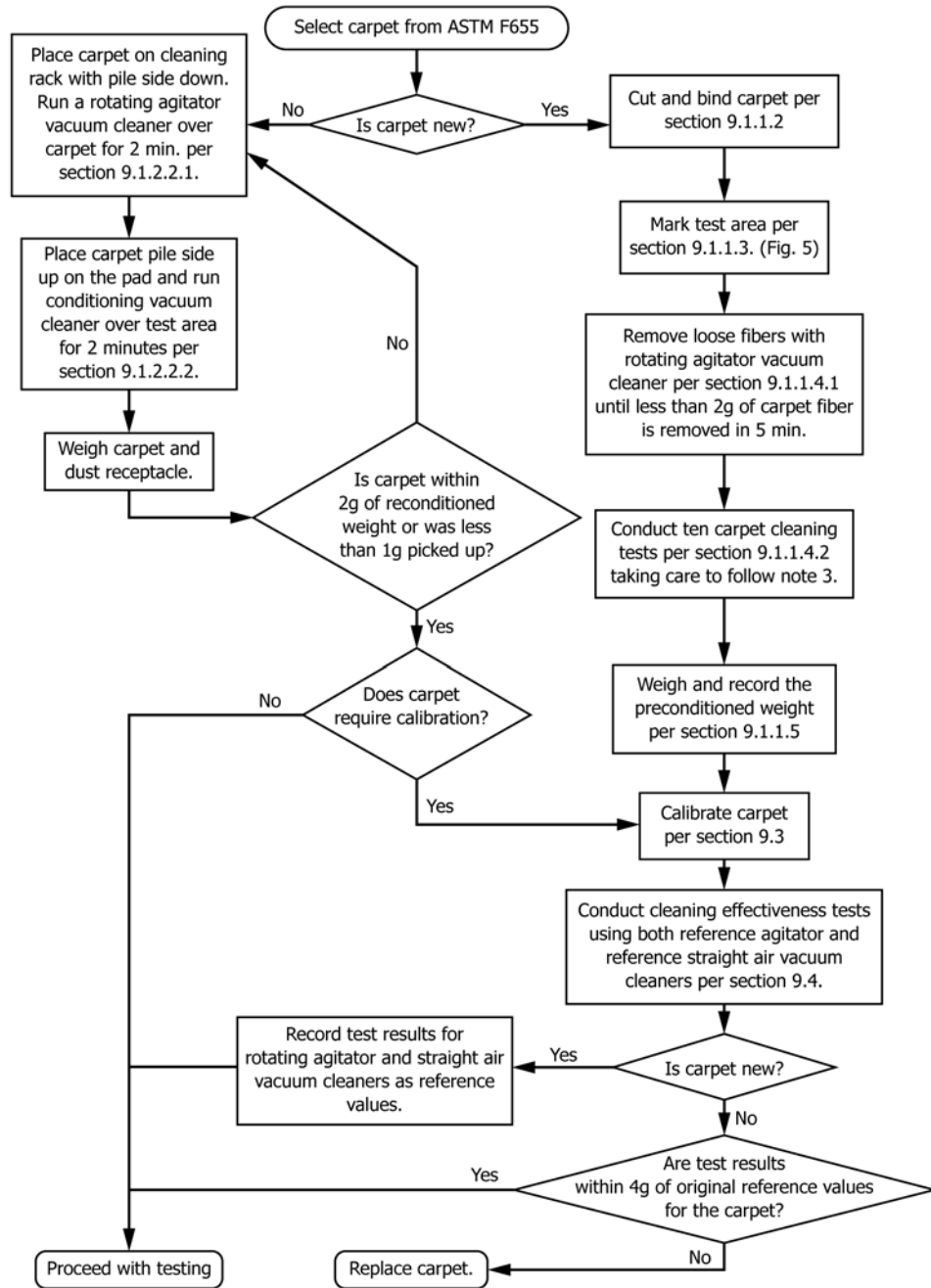

FIG. 1 Carpet Conditioning/Calibration Procedure

9. Procedure

9.1 Test Carpet Preparation:

9.1.1 Preconditioning New Test Carpet Samples:

9.1.1.1 New test carpets shall conform to Specification F655.

9.1.1.2 Cut a sample of each test carpet to a size of 27 by 72 in. (690 by 1830 mm) minimum. If the warp direction or “lay” of the carpet can be determined, it shall be in the 72 in. direction as indicated in Fig. 5. Carpets shall be bound on all sides.

9.1.1.3 Mark the test area on each carpet as indicated in Fig. 5.

9.1.1.4 Precondition New Test Carpet Samples:

(1) Precondition the entire area of the carpet by cleaning with the rotating agitator conditioning vacuum cleaner. Continue the operation until less than 2 g of carpet fiber is picked up in 5 min.

(2) Run ten carpet-embedded dirt removal effectiveness test runs in accordance with 9.4.2 – 9.4.18.

NOTE 3—Recondition the new test carpet following each preconditioning test run. It is not necessary, however, to meet the requirements set forth in 9.1.2.1 with respect to the preconditioned weight.

9.1.1.5 Weigh and record the preconditioned weight of the carpet.

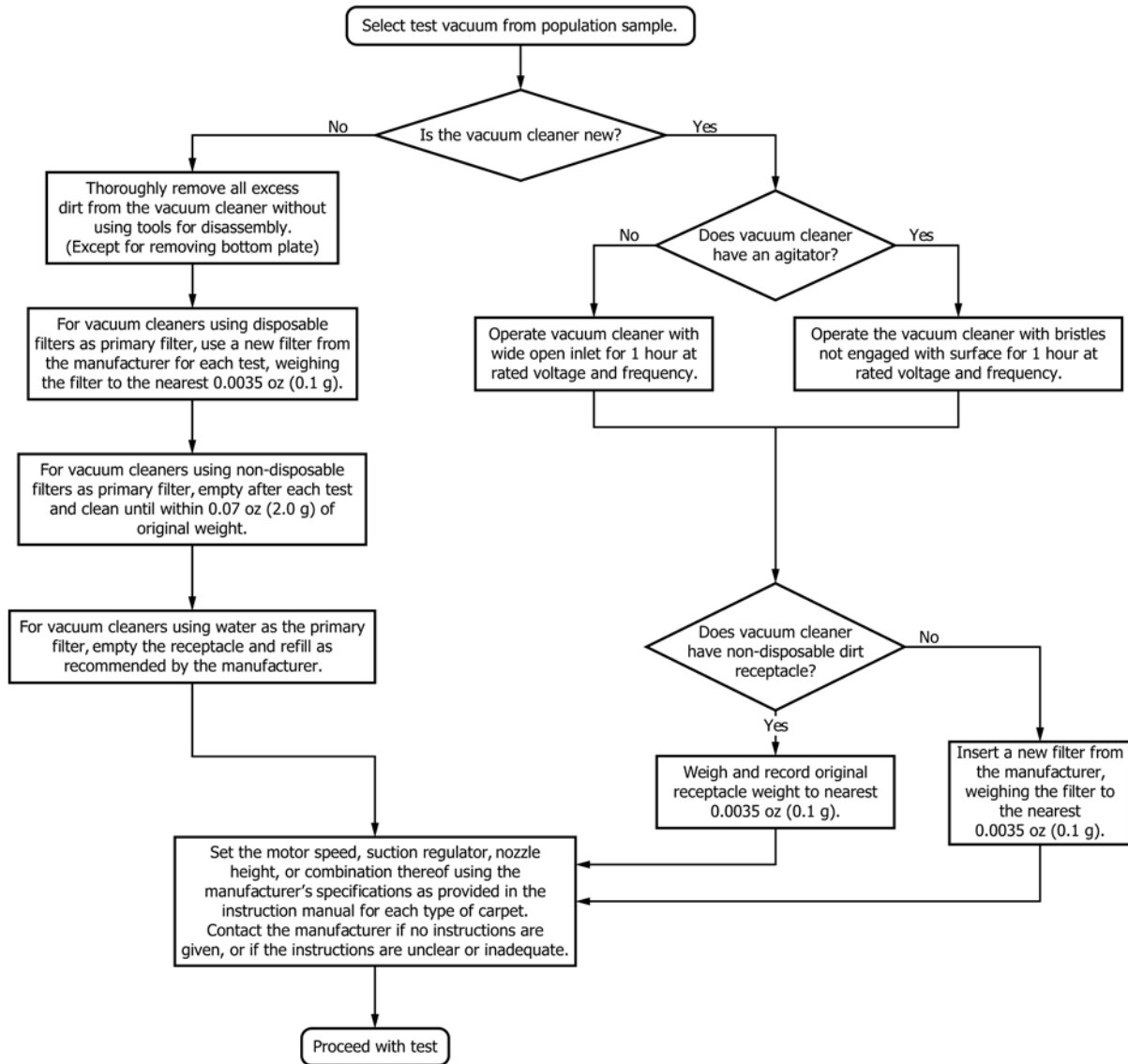

FIG. 2 Vacuum Cleaner Conditioning Procedure

9.1.1.6 Run a test carpet calibration in accordance with 9.3.

9.1.2 Reconditioning Used Test Carpet Samples:

9.1.2.1 Initial Daily Reconditioned Weight—At the beginning of each day, it is necessary to remove any dirt that may have settled on the carpet surface and stabilize the moisture content of the carpet. Clean the carpet with a rotating agitator conditioning vacuum cleaner until its weight does not exceed the initial reconditioned weight from the previous day of testing by more than 0.07 oz (2 g) or less than 0.035 oz (1 g) is picked up by the conditioning vacuum cleaner using the procedure in 9.1.2.3.

9.1.2.2 Following each test run, it is necessary to remove the residual dirt and stabilize the moisture content of the carpet. Clean the carpet with a rotating agitator conditioning vacuum cleaner until its weight does not exceed the initial daily reconditioned weight requirement of 9.1.2.1 by more than 0.07 oz (2 g) or less than 0.035 oz (1 g) is picked up by the conditioning vacuum cleaner using the following procedure.

9.1.2.3 Procedure:

(1) Place the carpet on the carpet cleaning rack (Fig. 4) with the pile side down. Run the rotating agitator conditioning vacuum cleaner over the carpet for 2 min, concentrating on the test area at 21.6 ± 0.8 in./s (0.55 ± 0.02 m/s); then run the rotating agitator conditioning vacuum cleaner thoroughly over the entire carpet area at least one time.

(2) Place the carpet (pile side up) on the pad, on the plywood supporting surface, and clean it with the rotating agitator conditioning vacuum cleaner for 2 min, concentrating on the test area; then run the rotating agitator vacuum cleaner thoroughly over the entire area at least one time.

(3) Weigh the carpet.

(4) Keep alternating 9.1.2.3(1) and 9.1.2.3(2), always ending with the pile side up, until the carpet weight meets the requirements of 9.1.2.1 or 9.1.2.2.

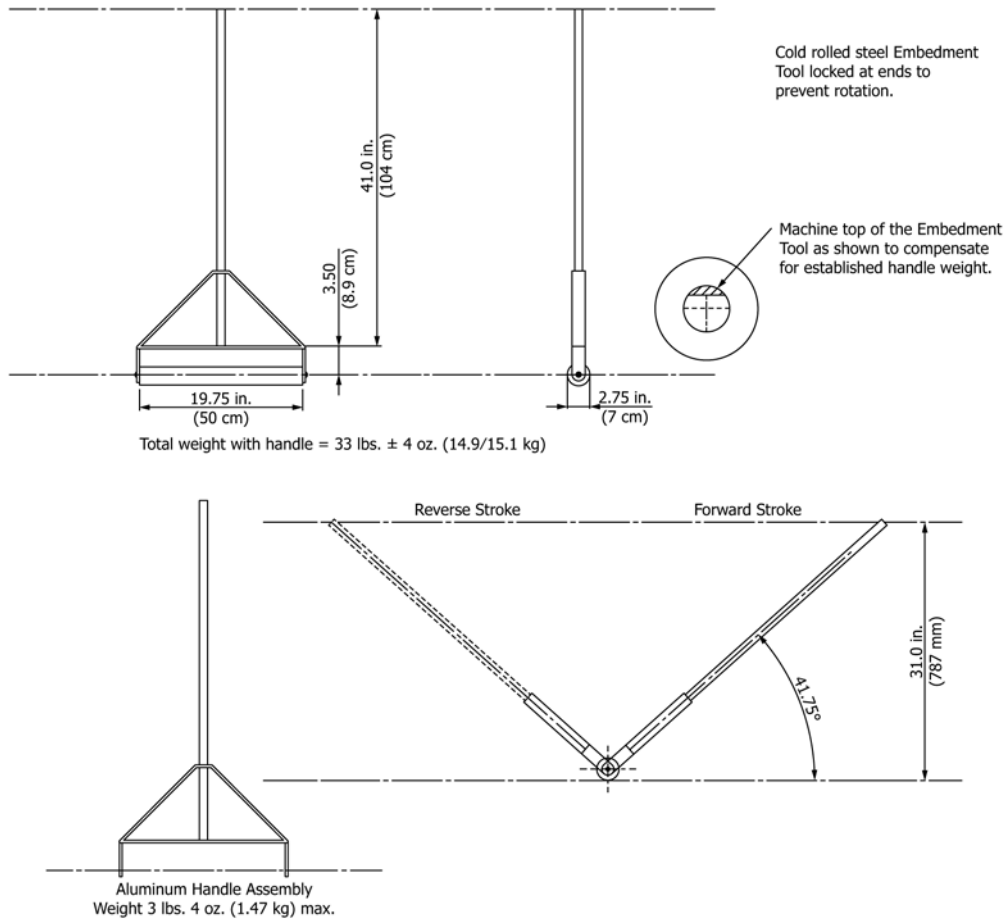

FIG. 3 Dirt Embedment Tool

(5) Change the disposable primary filter after a maximum of every 4 runs on the conditioning vacuum cleaner or more often if required.

NOTE 4—A high-cleaning performance rotating agitator vacuum cleaner is recommended for reducing the time to recondition the carpet.

9.1.3 Reconditioning Used Carpet Padding:

9.1.3.1 Clean the carpet padding by shaking weekly or more often, if necessary, to remove any collected dirt.

9.1.3.2 Replace the carpet padding when it has holes, tears, or other signs of wear.

9.2 Preparation of Test Vacuum Cleaners:

9.2.1 New Test Vacuum Cleaners:

9.2.1.1 For a vacuum cleaner that has not been used for any testing, run the vacuum cleaner in at rated voltage $\pm 1\%$ and rated frequency with filters in place.

(1) *Preconditioning a Rotating Agitator Type Vacuum Cleaner*—In a stationary position, operate the vacuum cleaner for 1 h with the agitator bristles not engaged on any surface.

(2) *Preconditioning a Straight-Air Type Vacuum Cleaner*—Operate the vacuum cleaner for 1 h with a wide-open inlet (without hose).

9.2.1.2 For vacuum cleaners with non-disposable dirt receptacles, weigh and record the receptacle’s original weight and any filters, to the nearest 0.0035 oz (0.1 g).

9.2.2 Used Test Vacuum Cleaners:

9.2.2.1 Recondition a used test vacuum cleaner, prior to each test run, as follows:

(1) Thoroughly remove excess dirt from the vacuum cleaner. Without using tools for disassembly, clean the entire outer surface, brushes, nozzle chamber, ductwork, inside of the chamber surrounding the primary filter, and inside hose and wands. Check the condition of all mechanisms for signs of wear or damage.

(2) For vacuum cleaners using disposable filters as the primary filters, use a new disposable primary filter from the manufacturer for each test run. Weigh the filter to the nearest 0.0035 oz (0.1 g) and install it as recommended by the vacuum cleaner manufacturer.

(3) For vacuum cleaners using water as the primary filter, empty the receptacle and refill as recommended by the manufacturer.

(4) For vacuum cleaners using non-disposable dirt receptacles, empty in accordance with the manufacturer’s instructions after each test run. The dust receptacle and any additional filters removable without the aid of tools shall, prior to each trial, be cleaned according to manufacturer’s instructions until its weight is within 0.07 oz (2 g) of its original weight. Weigh the combined receptacle and any integral filters to the nearest 0.0035 oz (0.1 g) and install as recommended by the vacuum cleaner manufacturer.

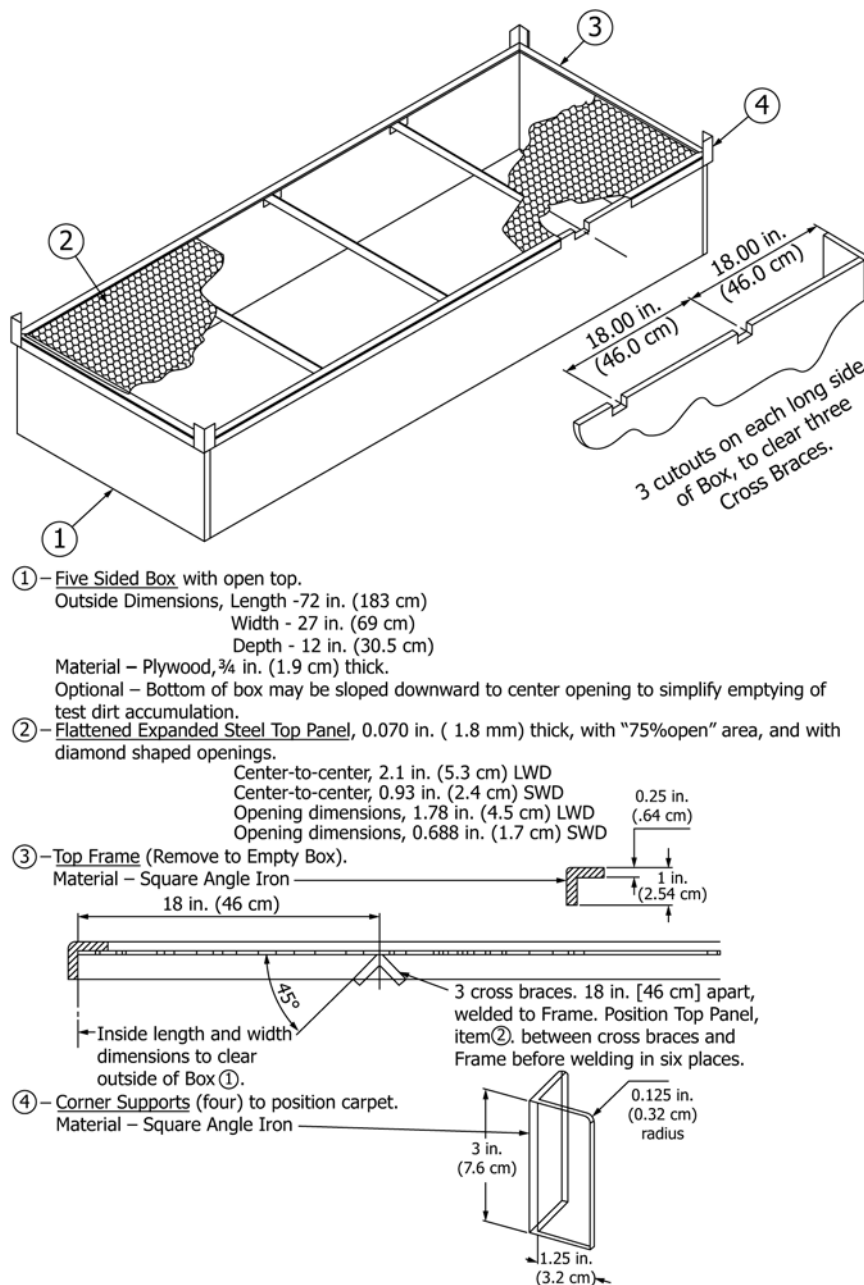

FIG. 4 Carpet Cleaning Rack

(5) Clean all secondary filters that are removable without the aid of tools in accordance with manufacturer's instructions until its weight is within 0.07 oz (2 g) of its original weight. Washing of filters is not permitted.

NOTE 5—It is recommended that a replaceable brush drive belt for vacuum cleaner agitators be changed after each four test runs, if considered applicable, using manufacturer's instructions. Any other maintenance task, such as cleaning the brush belt with distilled water, should only be done in accordance with manufacturer's recommendations.

9.2.3 Test Vacuum Cleaner Settings:

9.2.3.1 If various settings are provided, set the motor speed setting, suction regulator, nozzle height, or combination thereof using the manufacturer's specifications as provided in the instruction manual for each type of carpet. Contact the manufacturer if no instructions are given, or if the instructions are unclear or inadequate.

9.2.3.2 All straight line movement (see Test Method F1409), sound power (see Test Method F1334), edge cleaning (see Test Method F2608), energy measurement (see Test Method F2756), and motor life evaluation (see Specification

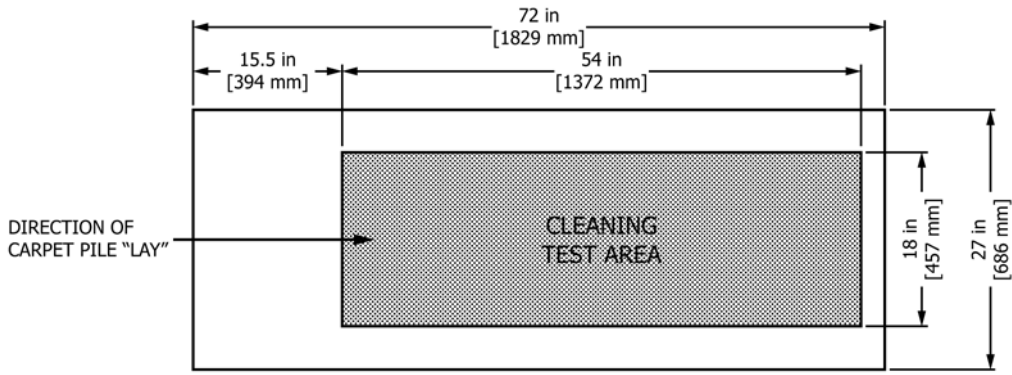

NOTE 1 – Cleaning test area should be positioned as shown. First forward stroke of cleaner is in direction with “lay” of carpet pile.

NOTE 3—Cleaning test area should be positioned as shown. First forward stroke of cleaner is in direction with “lay” of carpet.

NOTE 1—Cleaning test area should be positioned as shown. First forward stroke of cleaner is in direction with “lay” of carpet.

FIG. 5 Test Carpet

F655 and Test Methods F884, F922, and F1038) tests shall be conducted using the same settings (nozzle, motor speed, suction regulator, etc.) for each specific carpet.

9.2.4 Reference Vacuum Cleaners (Calibration):

9.2.4.1 Use the reference vacuum cleaners only for determining the reference rating of carpets and for the verification of carpet acceptability (see 9.3).

9.2.4.2 Maintain the performance of the reference vacuum cleaners throughout the acceptable life of the carpet (i.e. nozzle suction, bristle extension, motor and agitator speeds, etc.).

9.3 Test Carpet Calibration:

9.3.1 The purpose of calibration is to determine when the test carpet needs to be replaced by establishing a reference rating for each new preconditioned test carpet and to check this rating 50 or fewer test runs.

9.3.2 The reference ratings are determined for each test carpet by the percent pickup using the reference rotating agitator vacuum cleaner and the reference straight-air vacuum cleaner.

9.3.3 The percent pickup is determined by performing a carpet-embedded dirt removal effectiveness test (see 9.4).

9.3.4 When the embedded dirt rating for either reference cleaner varies by 0.14 oz (4 g) from the original reference rating for the carpet, replace the carpet.

9.3.4.1 All products being tested in a comparison test must be tested on the same calibrated carpet panels throughout the test program. If a particular carpet panel is found to no longer be acceptable for testing due to the 0.14 oz (4 g) limit being exceeded during a calibration check, all products tested on that particular carpet panel during the test program must be retested on the new carpet panel to ensure proper comparison.

NOTE 6—Carpet pick up changes over time as the test carpet panel is used due to normal carpet wear. General laboratory practice is to track and record the number of test runs on each carpet panel. It is recommended to estimate, as closely as possible, the number of required test runs on all carpet panels intended to be used prior to starting any test program in order to establish that the selected carpet panels have a sufficient number of test runs left to complete the test program.

9.4 Carpet Embedded Dirt Removal Effectiveness Test:

9.4.1 If preconditioning or reconditioning has been done more than 1 h before a test run, weigh the carpet. If the weight of the carpet exceeds the preconditioned or reconditioned weight by more than 0.07 oz (2 g), clean the carpet with a rotating agitator conditioning vacuum cleaner until these criteria are met.

9.4.2 Position the test carpet on the padding (with “scrim” side of the padding up) on the supporting surface (see 5.11).

9.4.3 The test cleaners and dirt receptacles should be prepared in accordance with 9.2.

9.4.4 Weigh the prepared dirt receptacle (that is, dust bag or other primary filter device) prior to conducting the measurement test run. Record the weight to the nearest 0.0035 oz (0.1 g).

9.4.5 Install the primary filter as explained below.

9.4.5.1 For vacuum cleaners using disposable or non-disposable primary filters, install the primary filter from the manufacturer per their instructions.

9.4.5.2 For vacuum cleaners using water as the primary filter, empty and refill the receptacle as recommended by the vacuum cleaner manufacturer.

9.4.6 Ensure that the vacuum cleaner settings have been made in accordance with 9.2.3.

9.4.7 Test Dirt Preparation—Weigh and mix 3.17 ± 0.0035 oz (90 ± 0.1 g) of silica sand and 0.35 ± 0.0035 oz (10 ± 0.1 g) of commercial grade talcum, both conforming to the specifications found in Annex A1.

9.4.7.1 Silica sand shall be sieved to assure conformance to the specification of A1.2. Sieving shall be performed in accordance with Test Method C136/C136M.

9.4.7.2 Bulk mixing and storage of sieved constituents of silica sand is acceptable if assay analysis meets the specification of A1.2.

9.4.7.3 Bulk storage of test dirt mixture (sand plus talc) is not allowed.

9.4.8 Distribute 3.52 oz (100 g) of the test dirt uniformly on the cleaning test area (see Fig. 5), using any convenient spreading method.

9.4.9 Embed the test dirt into the carpet using the dirt embedment tool shown in Fig. 3. Perform the embedding process by using a dragging motion in both directions with the handle held at the angle shown. Drag the dirt embedment tool over the test area exactly 30 strokes, alternating directions forward and back. (A movement in one direction is one “stroke.”) Use a uniform movement to provide a “stroke” time of 2.5 s (a rate of 21.6 ± 0.8 in./s (0.55 ± 0.02 m/s)). The first forward stroke shall be in the direction of the carpet lay. An acceptable laboratory practice shall be used to ensure that the embedment tool shall not fall short of reaching the end boundaries of the test area, and the tool shall cover both side boundaries of the test area at all times.

9.4.10 Clean the embedding tool as needed.

9.4.11 If the vacuum cleaner has not been energized for more than 60 min, energize the cleaner for 2 min at nameplate rated voltage ($\pm 1\%$) and frequency (± 1 Hz) immediately preceding the test sequence of 9.4.12. For vacuum cleaners with dual nameplate voltage ratings, conduct testing at the highest voltage.

9.4.11.1 For a rotating agitator-type vacuum cleaner, place it such that the bristles clear the supporting surface and no loose dirt is picked up.

9.4.11.2 For a straight-air canister vacuum cleaner, operate with the rug tool unrestricted, positioned such that no loose dirt is picked up from the supporting surface.

9.4.12 Immediately following the 2-min “run-in” of 9.4.11, de-energize the vacuum cleaner and place the vacuum cleaner nozzle on the test carpet so that the front edge of the vacuum cleaner coincides with the line defining the beginning of the test area and the right side of the boundary of the 18-in. test width (see Fig. 6). The forward stroke of the nozzle shall be in the direction of the carpet lay (see Fig. 5).

9.4.12.1 Reasonable efforts shall be made to maintain the handle height at 31.5 in. (0.8 m) during each test run for vacuum cleaners with a pivoting handle.

9.4.12.2 Reasonable efforts shall be made to maintain the vacuum cleaner’s nozzle parallel to the test carpet surface during each test run for vacuum cleaners with non-pivoting handles.

9.4.13 Tilt or lift the nozzle off the carpet, energize the vacuum cleaner, and adjust the voltage to rated voltage $\pm 1\%$. Allow the vacuum cleaner to run and expand the filter bag, if one is present.

9.4.14 *Test Cleaning Pattern:*

9.4.14.1 For a rotating agitator-type vacuum cleaner, lower the nozzle onto the carpet before the test area. Again, adjust the voltage to rated voltage $\pm 1\%$; then move the nozzle at a rate of 21.6 ± 0.8 in./s (0.55 ± 0.02 m/s) in the test cleaning pattern and motion as specified in Annex A2 during the cleaning cycle. Maintain the nozzle position and settings as specified in 9.2.3 during the cleaning cycle.

9.4.14.2 For a straight-air vacuum cleaner, position the nozzle on the carpet before the test area. Again, adjust the voltage to rated voltage $\pm 1\%$; then move the nozzle at a rate of 21.6 ± 0.8 in./s (0.55 ± 0.02 m/s) in the test cleaning patterns and motion as described in Annex A2. Maintain the nozzle position and settings as specified in 9.2.3 during the cleaning cycle.

9.4.14.3 At the end of the last stroke, smoothly tilt or lift the vacuum cleaner nozzle off the carpet and allow the vacuum cleaner to run an additional 10 s to clear the system of test dirt actually picked up but temporarily trapped within it before de-energizing the vacuum cleaner. During the additional run period, the hose used with the canister and combination vacuum cleaners should be flexed to help clear the system.

9.4.15 For vacuum cleaners with removable dirt receptacles, carefully remove the dust receptacle (dust bag or other primary filter device) and weigh it. Record the weight to the nearest 0.0035 oz (0.1 g).

9.4.15.1 For bagless dirt receptacles, remove the dirt receptacle assembly, including whatever filters it contains.

9.4.16 For vacuum cleaners using water as the primary filter, weigh the carpet to the nearest 0.035 oz (1.0 g).

9.4.17 Determination of the grams picked up for each test run will be done in the following manner:

9.4.17.1 For vacuum cleaners with removable dirt receptacles, subtract the weight of the clean dirt receptacle at the start of test from the weight of the dirt receptacle at the end of the test. Record results to the nearest 0.0035 oz (0.1 g).

9.4.17.2 For vacuum cleaners using constructions or technologies for which weighing a dirt receptacle, filter(s) or filter bag is impractical or does not provide reliable results, add 3.53 oz (100 g) to the weight of the carpet at the start of the test run and subtract the weight of the carpet at the end of the test run. Record results to the nearest 0.035 oz (1 g). If it is necessary to use the procedure in 9.4.17.2 for one vacuum cleaner in a

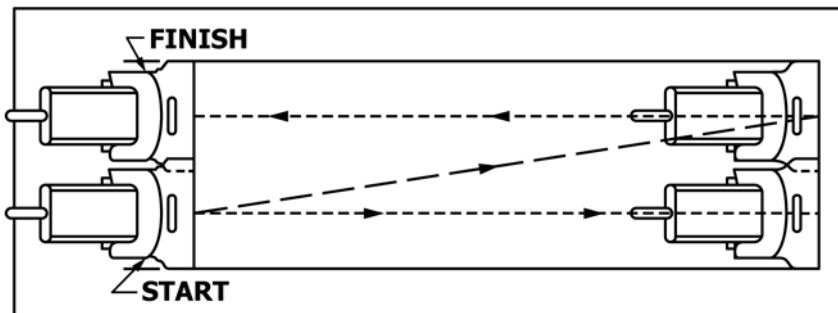

NOTE 1—This shows the nozzle positions for the cleaning pattern when $N = 2$. (Refer to Annex A2.)

FIG. 6 Cleaner Nozzle Position at Start and Finish of Test Cleaning Strokes

comparison test, the same method must be used for all vacuum cleaners in the comparison.

9.4.18 The percent carpet-embedded dirt removal effectiveness for a single test run of a given vacuum cleaner on a given carpet is the grams recorded in 9.4.17 expressed as a percentage.

9.4.19 Using the same test vacuum cleaner, repeat 9.4.1 – 9.4.18 two additional times for a total of three test runs.

9.4.19.1 If after three tests on the sample, the repeatability limits are not met, and no attributable reason for the outlier data can be determined, the results must be discarded and replaced with three new test runs (see A3.3.3).

NOTE 7—If after the first three tests on a *new vacuum cleaner sample*, the repeatability limits are not met due to the results of the first test run, the first test run may be discarded and replaced with an additional test run.

NOTE 8—If after three test runs, the repeatability limits are not met for a specific carpet, additional test runs may be conducted only on the particular carpet until the repeatability limits are met. It is not necessary to do additional test runs on all of the carpets. See Annex A4 for an example.

NOTE 9—If the test data is intended to be used for comparing different products of differing manufacture, it is strongly recommended that unless an automated test machine is used, the same operator conducts all testing involved in the comparison to minimize any potential effect different operators may have on the results. Assistance in reconditioning the carpets and unit under test may be provided by additional personnel.

9.4.20 The percent carpet-embedded dirt removal effectiveness for each individual test vacuum cleaner from the population sample for a given carpet is the average of three test runs meeting the repeatability statement in Section 11. See A3.3 for a procedural example and whether further test runs need to be conducted.

9.4.21 The percent carpet-embedded dirt removal effectiveness for each individual vacuum cleaner from the population sample is the geometric mean of the individual carpet values. See Annex A3 for a procedural example on calculating the geometric mean.

9.4.22 A minimum of two additional test sample units of the same model shall be selected in accordance with the sampling statement of Section 7. Repeat 9.4.1 – 9.4.20 for each new test sample unit selected.

9.4.23 The percent carpet-embedded dirt removal effectiveness for the population of the vacuum cleaner model being tested is the arithmetic mean of geometric mean values of the percent carpet-embedded dirt removal effectiveness from a sample of the population meeting the requirements of the sampling statement (Section 7).

10. Report

10.1 For each vacuum cleaner sample from the population being tested, report the following information:

10.1.1 Manufacturer’s name, product name, product model, and serial number.

10.1.2 Type of cleaner; that is, upright, canister, etc.

10.1.3 The average soil removed for each of the standard carpets specified in Specification F655 tested.

10.1.4 The geometric mean of the soil removal from all carpets specified in Specification F655 carpets.

10.2 The overall average(s), standard deviation(s), and 90 % confidence results for all of the population sample tested shall also be reported.

11. Precision and Bias

11.1 The following precision statements are based on inter-laboratory tests⁴⁻⁶ involving six laboratories and two test units (one upright vacuum cleaner with agitator and one canister with straight-air floor tool).

11.2 The statistics have been calculated as recommended in Practice E691.

11.3 The following statements regarding repeatability limit and reproducibility limit are used as directed in Practice E177.

11.4 The standard deviations of repeatability and reproducibility of the measured results have been derived from twelve sets of data, where each of two sets of three test runs have been performed by a single analyst within each of the six laboratories on separate days using the same test unit.

11.5 *Repeatability (Single Operator and Laboratory; Multiday Testing)*—The ability of a single analyst to repeat the test within a single laboratory.

11.5.1 The expected standard deviation of repeatability of the measured results within a laboratory, s_r , has been found to be the respective values listed in Table 1.

11.5.2 The 95 % repeatability limit within a laboratory, r , has been found to be the respective values listed in Table 1, where $r = 2.8(s_r)$.

⁴ Supporting data have been filed at ASTM International Headquarters and may be obtained by requesting Research Report RR:F11-1010.

⁵ Supporting data have been filed at ASTM International Headquarters and may be obtained by requesting Research Report RR:F11-1013.

⁶ Supporting data have been filed at ASTM International Headquarters and may be obtained by requesting Research Report RR:F11-1014.

TABLE 1 Repeatability and Reproducibility

Type Carpet	Type Cleaner	Standard Deviation of Repeatability, S_r	Repeatability Limit, r	Standard Deviation of Reproducibility, S_R	Reproducibility Limit, R
Plush	Agitator	1.0	2.8	3.4	9.5
	Straight Air	0.7	2.0	1.8	5.0
Multi-Level	Agitator	1.1	3.1	2.2	6.2
	Straight Air	0.9	2.5	3.9	10.9
Level Loop	Agitator	1.4	3.9	2.6	7.3
	Straight Air	1.3	3.7	6.6	18.5
Freize/Shag	Agitator	0.5	1.5	1.2	3.4
	Straight Air	0.16	0.4	0.4	1.1

11.5.3 With 95 % confidence, it can be stated that within a laboratory a set of measured results derived from testing a unit should be considered suspect if the difference between any two of the three values is greater than the respective value of the repeatability limit, r , listed in **Table 1**.

11.5.4 If the absolute value of the difference of any pair of measured results from three test runs performed within a single laboratory is not equal to or less than the respective repeatability limit listed in **Table 1**, that set of test results shall be considered suspect.

11.6 *Reproducibility (Multiday Testing and Single Operator Within Multilaboratories)*—The ability to repeat the test within multiple laboratories.

11.6.1 The expected standard deviation of reproducibility of the average of a set of measured results between multiple laboratories, s_R , has been found to be the respective values listed in **Table 1**.

11.6.2 The 95 % reproducibility limit within a laboratory, R , has been found to be the respective values listed in **Table 1**, where $R = 2.8(s_R)$.

11.6.3 With 95 % confidence, it can be stated that the average of the measured results from a set of three test runs performed in one laboratory, as compared to a second laboratory, should be considered suspect if the difference between those two values is greater than the respective values of the reproducibility limit, R , listed in **Table 1**.

11.6.4 If the absolute value of the difference between the average of the measured results from the two laboratories is not equal to or less than the respective reproducibility limit listed in **Table 1**, the set of results from both laboratories shall be considered suspect.

11.7 *Bias*—No justifiable statement can be made on the bias of the method to evaluate carpet-embedded dirt removal effectiveness of household/commercial vacuum cleaners since the true value of the property cannot be established by an acceptable referee method.

12. Keywords

12.1 dirt removal; vacuum cleaners

ANNEXES

(Mandatory Information)

A1. TEST DIRT

A1.1 *Test Dirt*, 100 g, consisting of the following:

A1.1.1 *Item 1*—90 g of silica sand⁷ in accordance with **A1.2**.

A1.1.2 *Item 2*—10 g of commercial grade talcum in accordance with **A1.3**.

A1.2 Silica sand in the following particle size range and amounts:

Sieve Range, U.S. No.	Particle Size, μm	Amount Used, g
–30/+40	600–425	0.9
–40/+50	425–300	31.5
–50/+70	300–212	41.4
–70/+100	212–150	13.5
–100/+140	150–106	2.7

A1.3 Commercial grade talcum with the following particle size distribution:

Particle Size Range, μm	Distribution by Weight, %
>44	0.5
43.9 to 20	12.5
19.9 to 10	27.0
9.9 to 5	23.0
4.9 to 2	20.0
1.9 to 1	8.0
<0.9	9.0

Note—Talc is used as an inflating agent for the filter bag.

⁷ The sole source of supply of the sand (Wedron No. 540 Unground Silica Sand) known to the committee at this time is The Wedron Silica Co., Customer Service Department, P.O. Box 119, Wedron, IL 60557. (The test dirt must be sieved to ensure conformance with the analysis limits. Use Test Method **C136/C136M**.) If you are aware of alternative suppliers, please provide this information to ASTM International Headquarters. Your comments will receive careful consideration at a meeting of the responsible technical committee,¹ which you may attend.

A2. TEST CLEANING PATTERN AND TIME

A2.1 *General*—All vacuum cleaners, regardless of the width of their nozzles, shall be moved back and forth in a specified pattern on the 54 by 18-in. (1370 by 460-mm) test area of the carpet for a total of exactly 16 strokes at the rate of 2.5 ± 0.1 s per stroke using any acceptable laboratory method to assure that these specifications are met. Examples of methods that have been found acceptable are visible-marked timing belt or a stopwatch to measure stroke time and cumulative time.

A2.1.1 Measure the outside width of the nozzle housing in inches.

A2.1.2 Divide the nozzle width into 18 and round the result to the nearest larger whole number identified henceforth as N .

A2.1.3 Divide the width of test area (18 in.) into N equal strips and mark the test area accordingly. Note that for any

vacuum cleaners having overall nozzle widths ranging from 3 to 17 in. the number of strips will be 6, 5, 4, 3, or 2.

A2.1.4 Place the vacuum cleaner nozzle on the test carpet so that the front edge of the vacuum cleaner coincides with the line defining the beginning of the test area and the right side of the nozzle coincides with the right side boundary shown in the applicable illustration. Ensure that each forward stroke ends with the front edge of the vacuum cleaner coincident with the end of the test area. When the vacuum cleaner reaches the extreme left strip, align the left side of the nozzle with the left side boundary of the test area. See Fig. 6. This shows the pattern for $N = 2$. For variations of the pattern where $N = 2$ to $N = 6$, see Fig. A2.1. Take care to ensure that during each stroke the side of the nozzle, right side or left side as applicable, is kept aligned with the side boundary of the test strip being cleaned, except for crossover strokes.

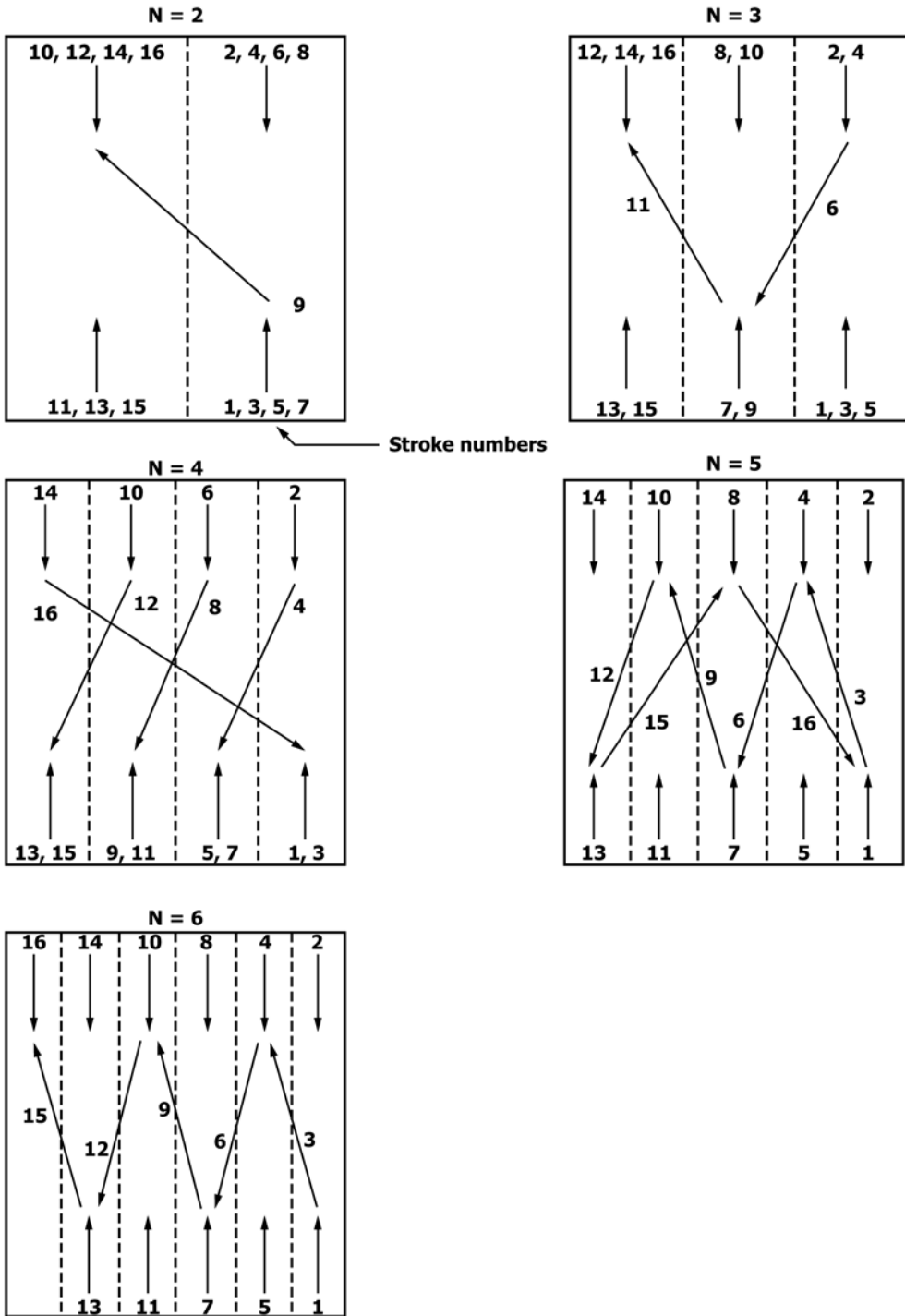

NOTE 1—The diagonal strokes shown in each pattern indicate that the test nozzle is moved from one stroke location to another during the diagonal stroke. There is no specific start or end point for the diagonal movement of the test nozzle during the diagonal stroke.

FIG. A2.1 Test Cleaning Patterns

A3. DETERMINATION OF THE POPULATION MEAN HAVING A 90 % CONFIDENCE INTERVAL

A3.1 Theory

A3.1.1 The most common and ordinarily the best estimate of the population mean, μ , is simply the arithmetic mean, \bar{X} , of the individual scores (measurements) of the units comprising a sample taken from the population. The average score of these units will seldom be exactly the same as the population mean; however, it is expected to be fairly close so that in using the following procedure it can be stated with 90 % confidence that the true mean of the population, μ , lies within 5 % of the calculated mean, \bar{X} , of the sample taken from the population.

A3.1.2 The following procedure provides a confidence interval about the sample mean which is expected to bracket μ , the true population mean, 100(1 - α)% of the time where α is the chance of being wrong. Therefore, 1 - α is the probability or level of confidence of being correct.

A3.1.3 The desired level of confidence is 1 - α = 0.90 or 90 % as stated in Section 7. Therefore α = 0.10 or 10 %.

A3.1.4 Compute the mean, \bar{X} , and the standard deviation, s , of the individual scores of the sample taken from the population:

$$\bar{X} = \frac{1}{n} \sum_{i=1}^n X_i \tag{A3.1}$$

$$s = \sqrt{\frac{\sum_{i=1}^n (X_i - \bar{X})^2}{(n - 1)}}$$

where:

- n = number of units tested, and
- X_i = the value of the individual test unit score of the i^{th} test unit. As will be seen in the procedural example to follow, this is the average value of the results from three test runs performed on an individual test unit with the resulting set of data meeting the repeatability requirements of Section 11.

A3.1.5 Determine the value of the t statistic for $n - 1$ degrees of freedom, df , from **Table A3.1** at a 95 % confidence level.

NOTE A3.1—The value of t is defined as $t_{1-\alpha/2}$ and is read as “ t at 95 % confidence”.

$$t \text{ statistic} = t_{1-\alpha/2} = t_{0.95} \tag{A3.2}$$

where:

$$1 - \alpha/2 = 1 - 0.10/2 = 1 - 0.05 = 0.95, \text{ or } 95 \%$$

A3.1.6 The following equations establish the upper and lower limits of an interval centered about \bar{X} that will provide the level of confidence required to assert that the true population mean lies within this interval:

$$CI_U = \bar{X} + ts/\sqrt{n} \tag{A3.3}$$

$$CI_L = \bar{X} - ts/\sqrt{n}$$

TABLE A3.1 Percentiles of the t Distribution

df	$t_{0.95}$
1	6.314
2	2.920
3	2.353
4	2.132
5	2.015
6	1.943
7	1.895
8	1.860
9	1.833
10	1.812
11	1.796
12	1.782
13	1.771
14	1.761
15	1.753

where:

- CI = confidence interval (U – upper limit; L – lower limit),
- \bar{X} = mean score of the sample taken from the population,
- t = t statistic from **Table A3.1** at 95 % confidence level,
- s = standard deviation of the sample taken from the population, and
- n = number of units tested.

A3.1.7 It is desired to assert with 90 % confidence that the true population mean, μ , lies within the interval, CI_U to CI_L , centered about the sample mean, \bar{X} . Therefore, the quantity ts/\sqrt{n} shall be less than some value, A , which shall be 5 % of \bar{X} in accordance with the sampling statement of 7.1.

A3.1.8 As $n \rightarrow \infty$, $ts/\sqrt{n} \rightarrow 0$. As this relationship indicates, a numerically smaller confidence interval may be obtained by using a larger number of test units, n , for the sample. Therefore, when the standard deviation, s , of the sample is large and the level of confidence is not reached after testing three units, a larger sample size, n , shall be used.

A3.2 Procedure

A3.2.1 Select three units from the population for testing as the minimum sample size.

A3.2.2 Obtain individual test unit scores with one of the following methods. The data set resulting from the three test runs performed on each individual test unit for each individual carpet shall meet the respective repeatability requirement found in Section 11.

A3.2.2.1 *Geometric Mean*—Calculate the geometric mean of the average results of three test runs performed on all carpets specified in Specification F655 for each of the three individual test units (see **Fig. A3.1**).

A3.2.2.2 *Individual Carpets*—Calculate the arithmetic mean of the results of three test runs performed on each of the carpets tested for each of the three individual test units (see **Fig. A3.2**).

A3.2.3 Compute \bar{X} and s of the sample.

A3.2.4 Compute the value of A where $A = 0.05(\bar{X})$.

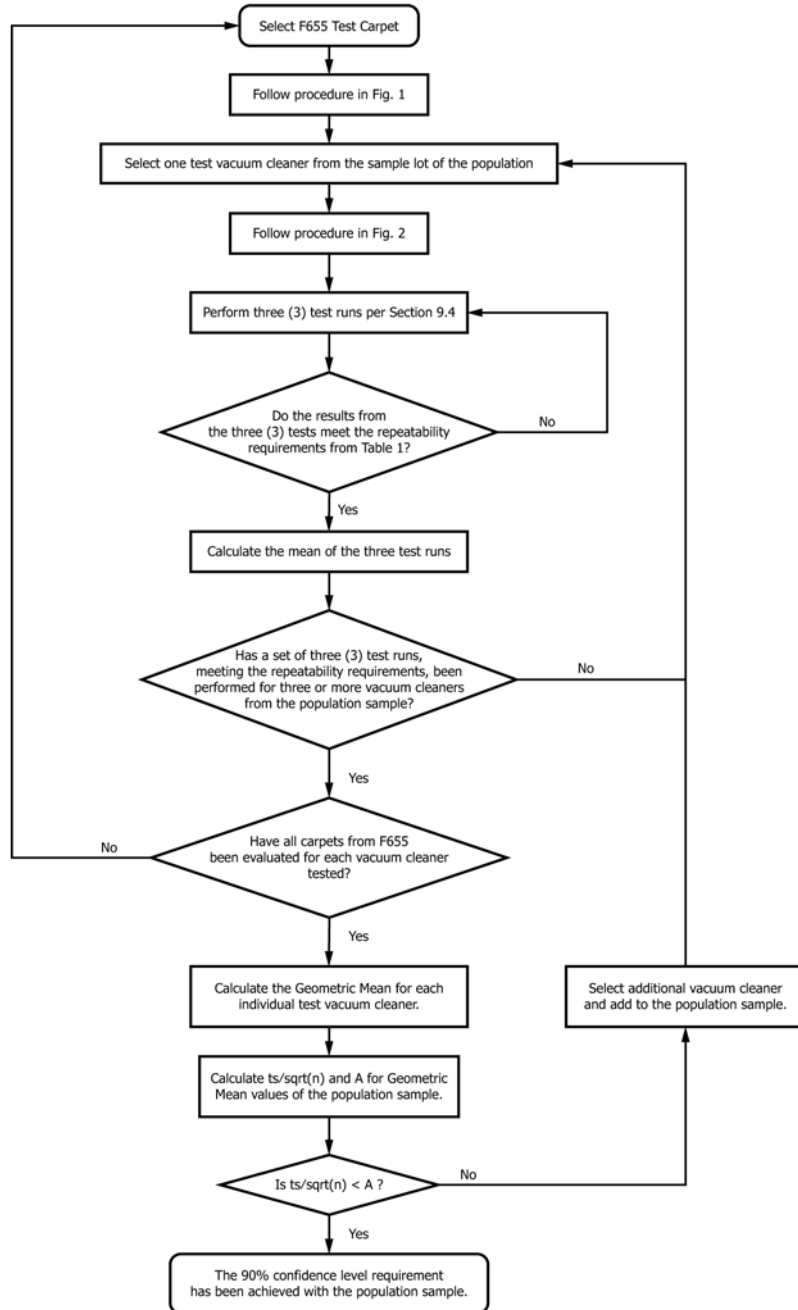

FIG. A3.1 Cleaning Effectiveness Test Procedure Using Geometric Mean

A3.2.5 Determine the statistic t for $n - 1$ degrees of freedom from Table A3.1 where n = the number of test units.

A3.2.6 Compute ts/\sqrt{n} for the sample and compare it to the value to A .

A3.2.7 If the value of $ts/\sqrt{n} > A$, an additional unit from the population shall be selected and tested, and the computations of A3.2.3 – A3.2.7 repeated.

A3.2.8 If the value of $ts/\sqrt{n} < A$, the desired 90 % confidence level has been obtained. The value of the final \bar{X} may be

used as the best estimate of the cleaning ability rating for the population.

A3.3 Examples

A3.3.1 The following data is chosen to illustrate how the value of embedded dirt cleaning ability for the population of an agitator type vacuum cleaner model, tested on ASTM Plush carpet, is derived. For this particular carpet, the measured test results from three test runs on each unit are required to have a repeatability limit not exceeding 2.816 as indicated in Table 1.

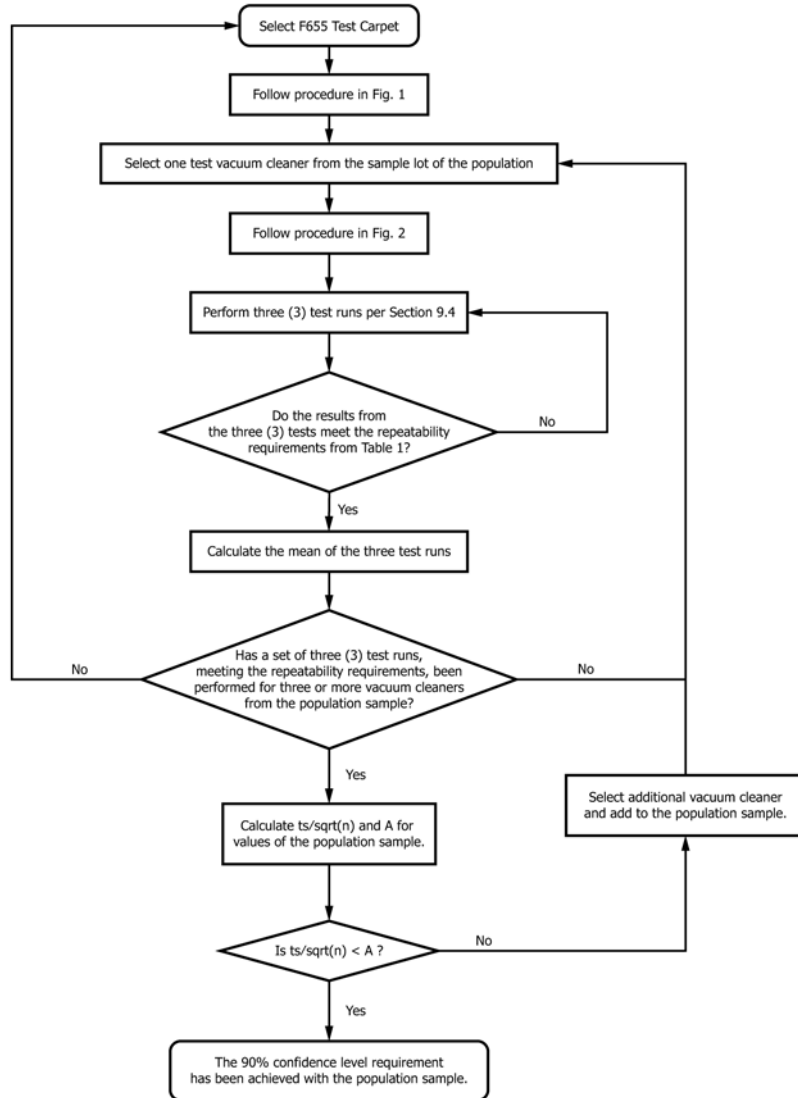

FIG. A3.2 Cleaning Effectiveness Test Procedure for Individual Carpets

A3.3.2 Select three test units from the vacuum cleaner model population. A minimum of three test runs shall be performed using each test run.

A3.3.3 Test run scores for test unit No. 1 on the Plush carpet:

test run No. 1 = 60.5
 test run No. 2 = 62.7
 test run No. 3 = 65.3

A3.3.4 Maximum spread = $65.3 - 60.5 = 4.8$. This value is greater than the repeatability limit required in Table 1. The results shall be discarded and three additional test runs performed. If after the first three tests on a new vacuum cleaner sample, the repeatability limits are not met due to the results of the first test run, the first test run may be discarded and replaced with an additional test run.

NOTE A3.2—If the scores of the first two test runs result in a difference greater than the repeatability limit required in Table 1, the scores may be discarded prior to conducting a third test run.

A3.3.5 Test run scores for test unit No. 1 on the Plush carpet:

test run No. 1 = 64.9
 test run No. 2 = 65.1
 test run No. 3 = 65.8

A3.3.6 Maximum spread = $65.8 - 64.9 = 0.9$. This value is less than the repeatability limit requirement of Table 1.

A3.3.7 Unit No. 1 score for Plush carpet = $(64.9 + 65.1 + 65.8)/3 = 65.27$.

NOTE A3.3—If it is necessary to continue repeated test run sets (7, 8, 9–10, 11, 12—etc.) because the spread of data within a data set is not less than the repeatability limit requirement stated in Table 1, there may be a problem with the test equipment, the execution of the test procedure, or any of the other factors involved in the test procedure. Consideration should be given to reevaluating all aspects of the test procedure for the cause(s).

A3.3.8 Testing the 90 % Confidence Interval for Individual Carpet Scores:

A3.3.8.1 A minimum of two additional test units must be tested, each meeting the repeatability limit requirement. For this procedural example, assume those units met the repeatability requirement and the individual unit scores are:

Score of test unit No. 1 = 65.27
 Score of test unit No. 2 = 69.53
 Score of test unit No. 3 = 67.41

$$\bar{X} = 1/3 (65.27 + 69.53 + 67.41) = 67.403$$

$$s = \frac{\sqrt{3[(65.27)^2 + (69.53)^2 + (67.41)^2] - [65.27 + 69.53 + 67.41]^2}}{3(3 - 1)}$$

$$s = 2.130$$

$$A = 0.05 (67.403) = 3.370$$

Degrees of freedom, $n - 1 = 3 - 1 = 2$; $t_{0.95}$ statistic = 2.920
 $ts/\sqrt{n} = 2.920 (2.130)/\sqrt{3} = 3.591$

$3.591 > 3.370$. The requirement that $ts/\sqrt{n} < A$ has not been met because s is larger. Therefore, an additional test unit from the population shall be tested.

Score of test unit No. 4 = 66.82

$$\bar{X} = 1/4 (65.27 + 69.53 + 67.41 + 66.82) = 67.258.$$

$$s = \frac{\sqrt{4[(65.27)^2 + (69.53)^2 + (67.41)^2 + (66.82)^2] - [65.27 + 69.53 + 67.41 + 66.82]^2}}{4(4 - 1)}$$

$$s = 1.763$$

$$A = 0.05 (67.258) = 3.363$$

Degrees of freedom, $n - 1 = 4 - 1 = 3$; $t_{0.95}$ statistic = 2.353
 $ts/\sqrt{n} = 2.353 (1.763)/\sqrt{4} = 2.075$

$2.075 < 3.363$ (meets requirements)

A3.3.8.2 Thus, the value of \bar{X} , 67.26, represents the embedded dirt cleaning ability score for the vacuum cleaner model tested on the given carpet and may be used as the best estimate of the cleaning ability rating for the population mean on that carpet.

A3.3.9 Calculating the Geometric Mean:

A3.3.9.1 To gain the geometric mean for an individual sample, a minimum of three test runs shall be conducted on each of the other test carpets. These scores shall meet the repeatability requirements listed in **Table 1**.

A3.3.9.2 Assuming that the unit being tested met the repeatability requirements for each of the carpet samples specified in **Specification F655**, the following scores were obtained:

Carpet Sample	Score
Plush	65.27
Multilevel	59.31
Level Loop	74.25
Shag	9.3

A3.3.9.3 The Geometric Mean for all of the carpets specified in **Specification F655** for each test unit can be calculated using the following formula:

$$\text{Geometric Mean} = \sqrt[n]{(X_1 \cdot X_2 \cdot X_3 \cdot \dots \cdot X_n)}$$

A3.3.9.4 For our example the Geometric Mean would be equal to:

$$\text{Geometric Mean} = \sqrt[4]{(65.27 \cdot 59.31 \cdot 74.25 \cdot 9.3)} = 40.43$$

A3.3.10 Testing the 90 % Confidence Interval for Geometric Mean Scores:

A3.3.10.1 A minimum of two additional test units must be tested. For this procedural example, assume those units met the repeatability requirements for each carpet sample and the individual unit scores are:

Score of test unit No. 1 = 40.43
 Score of test unit No. 2 = 43.41
 Score of test unit No. 3 = 41.23

$$\bar{X} = 1/3 (40.43 + 43.41 + 41.23) = 41.69$$

$$s = \frac{\sqrt{3[(40.43)^2 + (43.41)^2 + (41.23)^2] - [40.43 + 43.41 + 41.23]^2}}{3(3 - 1)}$$

$$= 1.54$$

$$A = 0.05 (41.69) = 2.08$$

Degrees of freedom, $n - 1 = 3 - 1 = 2$; $t_{0.95}$ statistic = 2.920
 $ts/\sqrt{n} = 2.920 (1.54)/\sqrt{3} = 2.60$

$2.60 > 2.08$. The requirement that $ts/\sqrt{n} < A$ has not been met because s is larger. Therefore, an additional test unit from the population shall be tested.

Score of test unit No. 4 = 41.64

$$\bar{X} = 1/4 (40.43 + 43.41 + 41.23 + 41.64) = 41.68.$$

$$s = \frac{\sqrt{4[(40.43)^2 + (43.41)^2 + (41.23)^2 + (41.64)^2] - [40.43 + 43.41 + 41.23 + 41.64]^2}}{4(4 - 1)}$$

$$= 1.26$$

$$A = 0.05 (41.68) = 2.08$$

Degrees of freedom, $n - 1 = 4 - 1 = 3$; $t_{0.95}$ statistic = 2.353
 $ts/\sqrt{n} = 2.353 (1.26)/\sqrt{4} = 1.48$

$1.48 < 2.08$ (meets requirements)

A3.3.10.2 Thus, the value of \bar{X} , 41.68, represents the embedded dirt cleaning ability score for the vacuum cleaner model tested and may be used as the best estimate of the cleaning ability rating for the population mean across all the carpets specified in **Specification F655**.

A4. EXAMPLE OF HANDLING DATA WHEN ONLY ONE CARPET DOES NOT MEET THE REPEATABILITY CRITERIA

A4.1 See [Table A4.1](#).

TABLE A4.1 Theoretical Data to Illustrate Calculating the 90 % Confidence for F608

	Plush	ML	Shag	Level Loop
1	35.0	33.0	2.0	48.0
2	36.0	31.5	2.5	46.0
3	34.0	32.0	2.6	47.0
			2.2	
			2.3	
			2.4	
			2.0	
			2.3	
Average	35.0	32.2	2.3	47.0
S	1.0	0.8	0.2	1.0
A	1.8	1.6	0.1	2.4
ts/sqrt(n)	1.7	1.3	0.1	1.7

APPENDIX

(Nonmandatory Information)

X1. IN-HOME CLEANING TEST

X1.1 Scope

X1.1.1 The purpose of this test is to determine a ratio of carpet-embedded dirt removal effectiveness and a home-carpet embedded removal effectiveness rating which can be used for comparing one or more vacuum cleaners against a standard vacuum cleaner and determining correlation with laboratory ASTM tests. The results are representative of the geographic area covered by the test homes.

X1.2 Summary of Method

X1.2.1 Each vacuum cleaner is tested in 25 homes in comparison with a standard vacuum cleaner. The grams of dirt picked up from the carpet in each home by each vacuum cleaner are accurately weighed. Each vacuum cleaner is manipulated over four segments of carpet 18 by 54 in. for 40 s per segment. The ratio of carpet-embedded dirt removal effectiveness equals the ratio of dirt picked up by the test vacuum cleaner (*B*) divided by dirt picked up by the standard

vacuum cleaner (*A*). The home vacuum cleaning effectiveness rating of vacuum cleaner (*B*) to that of vacuum cleaner (*A*) is the geometric mean of the values obtained in the 25 individual tests performed.

X1.3 Significance

X1.3.1 The ratio of carpet-embedded dirt removal effectiveness for specific vacuum cleaner determined by “in-home” tests can be compared to “in-laboratory” tests for correlation.

X1.4 Apparatus

X1.4.1 *Standard Vacuum Cleaner for Comparison*, either upright or canister with motorized agitator.

X1.4.2 *Frame*, inside effective area 18 by 54-in. (see [Fig. X1.1](#)).

X1.4.3 *Stop Watch*.

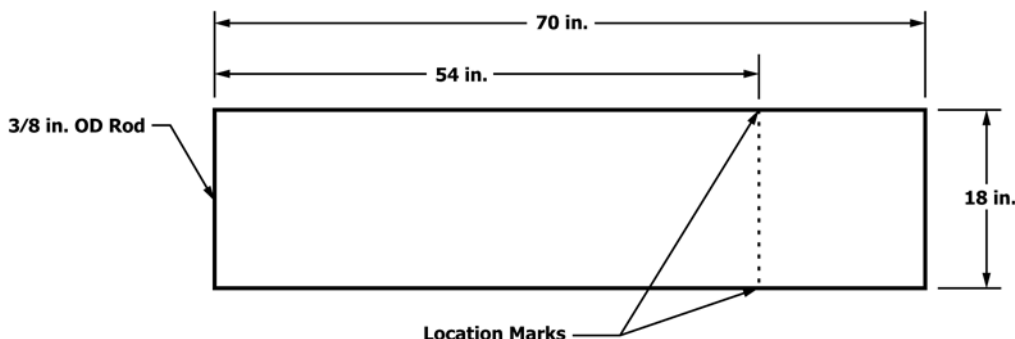

FIG. X1.1 Frame for In-Home Cleaning Test

X1.4.4 *Canister Vacuum Cleaner*, for conditioning vacuum cleaners between tests and for finishing cleaning the remaining test area.

X1.4.5 *Dust Bags, Dirt Cups, or Filters, or a Combination Thereof*, for appropriate vacuum cleaners.

X1.4.6 *Polyethylene Bags*, for sealing and transporting dust bags.

X1.4.7 *Balance Scale*, for weighing dust bags to within ± 0.01 g.

X1.4.8 *Test Vacuum Cleaner*.

X1.4.9 *Homes*, 25 with carpeted area suitable for selecting 9 by 6-ft test area. This area must not be obstructed to traffic by furniture or scatter rugs. Test homes shall be randomly located throughout the geographic test area. Carpet types and quality shall be representative of those commonly used in the home and must have been in service for at least six (6) months to be considered acceptable for cleaning effectiveness. Ozite, braided, excessively worn, thread-bare or carpets cleaned within three (3) days are not considered suitable for testing.

X1.4.10 *Adjustable Transformer*, for adjusting or controlling a voltage to the vacuum cleaner.

X1.4.11 *Voltmeter*, to measure input volts to the vacuum cleaner, provide measurements accurate to within ± 1 %.

X1.4.12 *Ammeter*, to measure input current to the vacuum cleaner, provide measurements accurate to within ± 1 %.

X1.4.13 *Manometer* (or equivalent pressure-sensing device), to ensure sealed suction of the vacuum cleaner, to provide measurements in inches of water accurate to within ± 0.10 in.

X1.4.14 *Tachometer(s)*, to measure motor speed in rpm and to ensure speed of agitator brush in rpm, accurate to ± 1 %.

X1.5 Preparation

X1.5.1 Identify standard unit and test unit such as model number, serial number, and unit test number.

X1.5.2 *Initial Performance Check*—Check the test vacuum cleaner and the reference vacuum cleaner in the laboratory prior to the test, for functional properties.

X1.5.2.1 Operate a new test vacuum cleaner with agitator, if equipped, energized but unloaded, for 30 min prior to conducting performance tests. New upright vacuum cleaners and combination (canister and motorized nozzle) vacuum cleaners shall also be operated on the back of woven carpet for 60 min to condition the agitator or brush roll brushes.

X1.5.2.2 For this test, operate each vacuum cleaner at rated voltage ± 1 % on the ASTM Plenum Chamber using a 1 ¼-in. diameter orifice for upright vacuum cleaners and a ¾-in. diameter orifice for canister vacuum cleaners. Record the input current in amperes, motor speed in rpm, agitator speed in rpm, sealed suction, and agitator brush extension.

X1.5.3 Each day prior to testing in the home, check sealed suction, amperes, and brush rpm. Obtain pretest performance measurements on the test carpet required for the completion of the In-Home Cleaning Effectiveness Test Data Sheet (Table

X1.1). The measurements shall be taken on an adjacent area of the carpet in the same condition. The load point for all pretest measurements is the average suction, established during the forward and reverse strokes of the vacuum cleaner. Care shall be taken that the area chosen for the pretest measurements has been cleaned prior to making measurements and that the vacuum cleaners are provided with clean filters or dirt cups, or both.

X1.5.4 Each vacuum cleaner is tested in 25 homes, in comparison to a standard vacuum cleaner. The test area is a 9 by 6-ft area made up of eight sections, each 18 by 54-in. (see Fig. X1.2). Corners of these areas are defined by masking tape in order to assist the operator. Areas *A* are cleaned with the known standard vacuum cleaner. Areas *B* are cleaned with the vacuum cleaner being tested. Bulky litter, such as hair pins, string, paper, etc., shall be removed manually from the test area prior to testing.

X1.5.4.1 General information regarding carpet, padding, cleaning frequency and type of vacuum cleaner used shall be obtained from the home owner and recorded in the data sheet.

X1.5.4.2 Locate the test area with regard to some reference point in the home and sketch the alternative test segments *A* and *B*. Identify the carpet as to fiber, pile height, and type. Also record if padding is used under the carpet in each home tested, and the type of padding (rubber, foam, or felt).

X1.5.5 Each segment (A_1 or A_2 or B_1 , etc.) shall be cleaned using the same pattern of strokes, stroke time, and total time as established in this test method.

X1.5.6 The sequence of cleaning the segments of the carpet test area shall be A_1 , A_2 , A_3 , then A_4 with the standard vacuum cleaner, then B_1 , B_2 , B_3 , then B_4 with the test vacuum cleaner.

X1.5.7 Use the frame as a guide for cleaning the 18 by 54-in. segment.

X1.5.8 The nozzle heights on the test and reference vacuum cleaners shall be set in accordance with the specification under “Test Vacuum Cleaner Setting” in this test method.

X1.5.9 Prior to leaving the laboratory, weigh each dust bag or dirt cup to the nearest ± 0.01 g and record. Seal the dust bag or dirt cup in a polyethylene bag. Install the bag or dirt cup in the vacuum cleaner just prior to test.

X1.5.10 Vacuum out each test unit prior to running each home test with a standby vacuum cleaner. In the case of a canister vacuum cleaner or an upright vacuum cleaner with integral hoses, vacuum out the hose, wands, and nozzle between each test.

X1.6 Test Procedure

X1.6.1 Clean each test area of the carpet using the following procedure:

X1.6.1.1 Place the vacuum cleaner nozzle on the carpet so that the rear lip of the nozzle is at the start of the test area and the right side of the nozzle is aligned with the right side of the test area.

X1.6.1.2 Tilt the nozzle off the carpet and energize at rated voltage and frequency.

TABLE X1.1 In-Home Cleaning Data Sheet

Cleaner Information:		Type	Name	Model No.	Serial No.				
Cleaner A:									
Cleaner B:									
Physical and Functional Properties of the Vacuum Cleaner									
Orifice Used	Speeds (RPM)				Suction (Inches H ₂ O)	Volts	Watts		
A:	Motor		Agitator or Brush Roll						
B:	A	B	A	B	A	B	A B		
Control Carpet									
Before Test									
After Tests									
Average									
Orifice Values									
Before Test									
After Tests									
Average									
Carpet Data									
Test	Dirt removed from 27ft ² (grams)		Individual Rating (B/A)×100	Geometric rating	Test	Dirt removed from 27ft ² (grams)		Individual Rating (B/A)×100	Geometric rating
	A	B				A	B		
1					14				
2					15				
3					16				
4					17				
5					18				
6					19				
7					20				
8					21				
9					22				
10					23				
11					24				
12					25				
13					Average				
Physical measurements:					In-home Cleaning Effectiveness Rating:				
Nozzle height setting used:					Geometric Mean:				
Nozzle height from surface at height setting:					95 % Confidence limit:				
Bristle extension:					Date:				
					Signed:				
Home Location and Carpet Information									
Home location									
Carpet location (living room, bedroom, kitchen, etc.)									
Carpet type (style, fiber, pile height)									
Carpet padding (if used) (type, height)									
Carpet general condition									
Normal frequency of cleaning									
Type of vacuum cleaner used (Type, name and model)									
Comments and remarks									

X1.6.1.3 For a rotating agitator-type vacuum cleaner, lower the nozzle onto the carpet before the test area. Again, adjust the voltage to rated voltage $\pm 1\%$; then move the nozzle at a rate of 21.6 ± 0.8 in./s (0.55 ± 0.02 m/s) in the test cleaning pattern and motion as specified in **Annex A2** during the cleaning cycle. Maintain the nozzle position and settings as specified in **X1.5.8** during the cleaning cycle.

X1.6.1.4 For a straight-air vacuum cleaner, position the nozzle on the carpet before the test area. Again, adjust the voltage to rated voltage $\pm 1\%$; then move the nozzle at a rate of 21.6 ± 0.8 in./s (0.55 ± 0.02 m/s) in the test cleaning patterns and motion as described in **Annex A2**. Maintain the nozzle position and settings as specified in **X1.5.8** during the cleaning cycle.

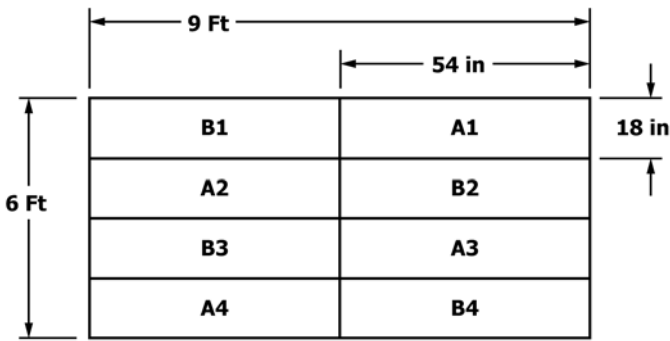

FIG. X1.2 Test Area

X1.7 Report

X1.7.1 Data for each vacuum cleaner and test shall be recorded on the data sheet shown in [Table X1.1](#).

X1.7.2 Summary data shall be reported on the In-Home Cleaning Summary Sheet shown in [Fig. X1.3](#).

X1.8 Data Treatment

X1.8.1 The ratio of carpet embedded dirt removal effectiveness for a single home is equal to the dirt picked up by Vacuum Cleaner B from areas $B_1 + B_2 + B_3 + B_4$ divided by the dirt picked up by Vacuum Cleaner A from areas $A_1 + A_2 + A_3 + A_4$ and is calculated as follows:

$$\text{Cleaning Effectiveness Ratio} = B/A \quad (X1.1)$$

$$A = (A_1 + A_2 + A_3 + A_4)$$

$$B = (B_1 + B_2 + B_3 + B_4)$$

X1.8.2 The home cleaning effectiveness rating of Vacuum Cleaner B to that of Vacuum Cleaner A is the geometric mean of the values obtained in the 25 individual tests performed.

X1.9 Cleaning Effectiveness Rating X1.9

$${}^N \sqrt{\left(\frac{B_1}{A_1}\right) \left(\frac{B_2}{A_2}\right) \left(\frac{B_3}{A_3}\right) \dots \left(\frac{A_N}{B_N}\right)} \quad (X1.2)$$

where:

N = number of homes in which this test was conducted.

X1.6.1.5 At the end of the last stroke, smoothly tilt or lift the vacuum cleaner nozzle off the carpet and allow the vacuum cleaner to run an additional 10 s to clear the system of test dirt actually picked up but temporarily trapped within it before de-energizing the vacuum cleaner. During the additional run period, any hose used with the vacuum cleaner should be flexed to help clear the system.

X1.6.1.6 After the test, remove the filter bag or dirt cup from the vacuum cleaner, place it in the plastic bag and reseal the bag for transporting until time for second weighing. Then reseal and retain the bag until test is completed.

X1.6.1.7 Determine the dirt weight in the dust bag for the standard and for the test vacuum cleaner. The difference between the initial and final weight of the assembly is the weight of the dirt removed by the vacuum cleaner. The test results shall be used only if the amount of dirt removed is 3 g or more for each vacuum cleaner.

In-Home Cleaning Summary Data Sheet

Standard vacuum cleaner:
Tart vacuum cleaner:

Series	Total Hr.	Rating		Input Power [W]		Holar Speed [RPH]		Aqilater Speed [RPH]		[-H2O]		Height	Location	Date
		A	P	Avg	A	P	A	P	A	P	A			
#1	1													
#1	2													
#1	3													
#1	4													
#1	5													
#1	6													
#1	7													
#1	8													
#1	9													
#1	10													
#1	11													
#1	12													
#1	13													
#1	14													
#1	15													
#1	16													
#1	17													
#1	18													
#1	19													
#1	20													
#1	21													
#1	22													
#1	23													
#1	24													
#1	25													

Comments:

Page 1

In-Home Cleaning Summary Data Sheet

Series	Total Hr.	Material	Carpet Style				Pile	Pile Height (inches)	Pile Condition	Carpet Pad	Owner's Vacuum Cleaner	Test Vacuum
			Plank	Multi-Level	Stag	Loop/Loop						
#1	1											
#1	2											
#1	3											
#1	4											
#1	5											
#1	6											
#1	7											
#1	8											
#1	9											
#1	10											
#1	11											
#1	12											
#1	13											
#1	14											
#1	15											
#1	16											
#1	17											
#1	18											
#1	19											
#1	20											
#1	21											
#1	22											
#1	23											
#1	24											
#1	25											

* PRP [Pann Rubber Duck], R [Rubber], FJ [Fell/Star], H [Hose]
Comments:

Page 2

FIG. X1.3 In-Home Cleaning Summary Sheet

ASTM International takes no position respecting the validity of any patent rights asserted in connection with any item mentioned in this standard. Users of this standard are expressly advised that determination of the validity of any such patent rights, and the risk of infringement of such rights, are entirely their own responsibility.

This standard is subject to revision at any time by the responsible technical committee and must be reviewed every five years and if not revised, either reapproved or withdrawn. Your comments are invited either for revision of this standard or for additional standards and should be addressed to ASTM International Headquarters. Your comments will receive careful consideration at a meeting of the responsible technical committee, which you may attend. If you feel that your comments have not received a fair hearing you should make your views known to the ASTM Committee on Standards, at the address shown below.

This standard is copyrighted by ASTM International, 100 Barr Harbor Drive, PO Box C700, West Conshohocken, PA 19428-2959, United States. Individual reprints (single or multiple copies) of this standard may be obtained by contacting ASTM at the above address or at 610-832-9585 (phone), 610-832-9555 (fax), or service@astm.org (e-mail); or through the ASTM website (www.astm.org). Permission rights to photocopy the standard may also be secured from the Copyright Clearance Center, 222 Rosewood Drive, Danvers, MA 01923, Tel: (978) 646-2600; <http://www.copyright.com/>