



Standard Practice for Using a 1.707-m [67.23-in.] Diameter Laboratory Test Roadwheel in Testing Tires¹

This standard is issued under the fixed designation F551/F551M; the number immediately following the designation indicates the year of original adoption or, in the case of revision, the year of last revision. A number in parentheses indicates the year of last reapproval. A superscript epsilon (ϵ) indicates an editorial change since the last revision or reapproval.

1. Scope

1.1 This practice covers the requirements for a 1.707-m [67.23-in.] diameter laboratory roadwheel for durability and endurance testing of tires under controlled operating and environmental conditions.

1.2 The values stated in either SI units or inch-pound units are to be regarded separately as standard. The values stated in each system may not be exact equivalents; therefore, each system shall be used independently of the other. Combining values from the two systems may result in non-conformance with the standard.

1.3 *This standard does not purport to address all of the safety concerns, if any, associated with its use. It is the responsibility of the user of this standard to establish appropriate safety and health practices and determine the applicability of regulatory limitations prior to use.* For specific precautionary statements, see Section 7 and Note 1.

2. Referenced Documents

2.1 *ASTM Standards:*²

F538 Terminology Relating to the Characteristics and Performance of Tires

3. Terminology

3.1 *Definitions*—Definitions given in Terminology **F538** are regarded as standard.

4. Summary of Practice

4.1 This practice describes the specifications and dimensions of a 1.707-m [67.23-in.] diameter laboratory roadwheel system for testing of one or more tire assemblies under

controlled conditions. It also describes the calibration procedures for the standard operation of the wheel.

5. Significance and Use

5.1 The 1.707-m [67.23-in.] diameter laboratory test roadwheel is one of the most extensively employed testing devices for tire durability and endurance testing.

5.2 This test apparatus operating in the laboratory at controlled surface speeds, loads, and ambient temperatures simulates, to a degree, tire-operating conditions resembling actual service. Because of the roadwheel curvature, the test tire is fatigued more rapidly than a tire operating on a road.

5.3 The laboratory roadwheel described in this practice is suitable for comparative evaluation of tires under controlled operating and environmental conditions.

5.4 While the laboratory roadwheel may not reproduce structural fatigue exactly as it occurs in service, the laboratory wheel can be used to produce fatigue under controlled conditions.

6. Apparatus

6.1 *Laboratory Test Roadwheel*—A laboratory test roadwheel consists of a large steel wheel against which one or more tire-wheel assemblies are pressed at specific loads (see Fig. 1).

6.1.1 The roadwheel shall have an outside diameter of 1.707 m [67.23 in.] \pm 0.5 %. This dimension originated from the choice of the circumference of the roadwheel as being $\frac{1}{300}$ mile.

6.1.2 The width of the roadwheel shall be such that the edges are not in contact with the tire under test.

6.1.3 The surface roughness of the roadwheel that is in contact with the tire shall not be in excess of 3.18 μm [125 $\mu\text{in.}$] and must be continuous and without holes or projections. Where it is necessary to provide for the affixing of special test accessories such as cleats, the empty bolt holes in the path of the tire contact width should be plugged, so as to match the wheel curvature and be within the maximum specified surface roughness.

6.1.4 The total indicated radial runout of the wheel shall not exceed 0.25 mm [0.01 in.].

6.2 Loading System:

¹ This practice is under the jurisdiction of ASTM Committee F09 on Tires and is the direct responsibility of Subcommittee F09.10 on Equipment, Facilities and Calibration.

Current edition approved Jan. 1, 2016. Published February 2016. Originally approved in 1977. Last previous edition approved in 2009 as F551/F551M – 09a. DOI: 10.1520/F0551_F0551M-16.

² For referenced ASTM standards, visit the ASTM website, www.astm.org, or contact ASTM Customer Service at service@astm.org. For *Annual Book of ASTM Standards* volume information, refer to the standard's Document Summary page on the ASTM website.

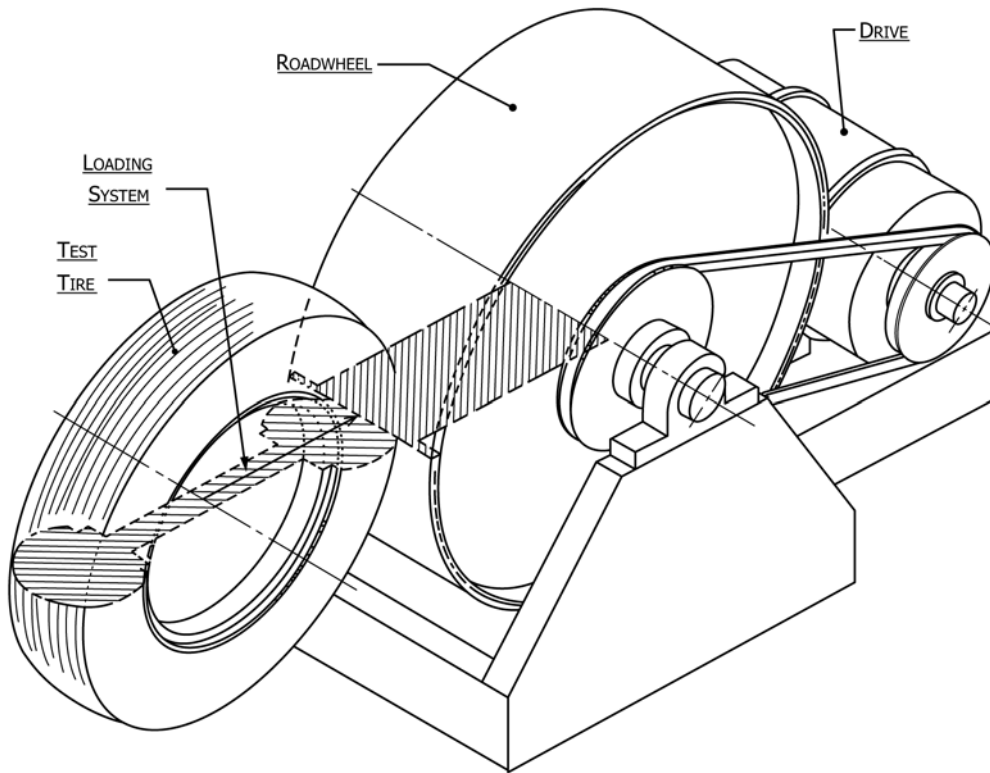

FIG. 1 Laboratory Tire Test Roadwheel

6.2.1 The loading system shall be capable of applying and controlling the tire loading force to the desired level.

6.2.2 The tire loading force shall pass through the axis of the tire under test and the axis of the roadwheel at all times.

6.2.3 The axis of rotation of the roadwheel and the axis of rotation of the tire undergoing test shall be parallel within 10 min of arc for camber and slip angle.

6.2.4 Each tire-loading system should be equipped with a device that causes the tire to be retracted from the roadwheel immediately upon its reaching a preset deflection indicative of tire failure or air loss.

6.3 *Drive*—The drive shall be capable of rotating the roadwheel and maintaining the desired surface speed under all load conditions.

6.4 *Ambient Temperature Conditions*—Please refer to the test method used for specifics regarding ambient temperature and measuring distance requirements. If there is no referenced test method, ambient temperature surrounding the tires shall be controlled at $38 \pm 3^\circ\text{C}$ [$100 \pm 5^\circ\text{F}$] measured at a point located $305 \pm 37\text{ mm}$ [$12 \pm 1.5\text{ in.}$] from any point of the edge of the rim flange for all operating conditions.

6.5 *Instrumentation:*

6.5.1 Equipment shall be provided to indicate roadwheel surface speed and to provide a measure of the linear equivalent distance traveled.

6.5.2 Optional equipment may be provided to indicate or record, or both, the load, ambient temperature, and inflation pressure, and to record the roadwheel speed.

6.6 *Control Tolerances on Speed, Load, and Distance:*

Wheel Speed	Tolerance
Up to 80 km/h [50 mph]	$\pm 0.8\text{ km/h}$ [$\pm 0.5\text{ mph}$]
80 to 400 km/h [50 to 250 mph]	$\pm 1.6\text{ km/h}$ [$\pm 1.0\text{ mph}$]
Normal Force	Tolerance
At Specified Load	$\pm 1\%$
Linear Travel of the Test	Tolerance
Wheel Surface	$\pm 0.5\%$

7. Safety Precautions

7.1 The tire, rim, and wheel must be free of obvious defects, as judged by visual inspection. In particular, the bolt holes, the valve, and the base of the rim flange must not be worn excessively.

7.2 *Hazards During Roadwheel Tire Testing*—A tire is a pressure vessel that experiences changes due to the conditions of the test. Laboratory roadwheel test conditions, including load, inflation, speed, pressure, and temperature, are intended to generate end of test conditions. Therefore, a rapid loss of air pressure shall be anticipated at every stage of the test. Such an event may be accompanied by fragments having a high energy level being thrown from the tire being tested. Appropriate machine safeguards and fire and personal protection equipment shall be provided at all times.

8. Calibration

8.1 Use a system calibration.

8.2 Calibration standards shall be comprised of instrumentation and measuring apparatus that are used for verification of

the accuracies of the indicating-recording instrumentation associated with the laboratory wheel. Calibration standards shall be of sufficient accuracy and resolution to ensure that the indicating-recording instrumentation system subject to calibration is accurate to the tolerances listed in 6.6. Calibration standard accuracy will be ascertained by comparison of the standard with primary standards maintained by the National Institute of Standards and Technology (NIST) or secondary standards traceable to NIST. The frequency of calibration shall be at least every six months and as often as necessary to ensure that all functions are within the tolerances listed in 6.6.

NOTE 1—**Caution:** This instrumentation shall be used only for purposes of calibration and shall be maintained in a manner that will ensure the retention of their accuracies between calibration intervals.

8.3 *Tire Load (Force)*—The calibration of the tire-loading system shall consist of orienting a force transducer standard so that it is subjected to the normal force applied to a tire that has been forced against the surface of the roadwheel. Apply a series of loads (forces) covering the range of increasing and decreasing load intervals normally employed during testing, and the load (force) values obtained from the standard, compared with those obtained from the indicating-recording system associated with the roadwheel. The load intervals used for calibration purposes shall be small enough and repeated at least once to enable determination of linearity trends and repeatability of the indicating-recording system.

8.4 *Speed*—Perform the calibration of the roadwheel surface speed indicating-recording system by comparing the linear surface velocity of the wheel with an appropriate standard. A linear surface velocity observation may be made at the periphery of the wheel or obtained by determining the frequency of the roadwheel revolutions at the shaft and computing the linear surface velocity. Operate the roadwheel throughout the range of speeds employed during testing and the speed values obtained with the standard compared to those indicated or

recorded by the usual instrumentation. For calibration purposes, the speed intervals used should be small enough, of sufficient duration, and repeated at least once to enable determinations of linearity and repeatability trends of the indicating-recording system.

8.5 *Inflation Pressure Monitoring Equipment (Optional)*—Perform the calibration of the tire inflation pressure indicating-recording system by direct comparison with an appropriate pressure transducer standard accurate to ± 1.7 kPa [± 0.25 psi]. Make the comparison with the two systems in pressure equilibrium. Set the pressure source to values throughout the range of inflation pressure normally experienced during the test. The intervals chosen should be small enough, of sufficient duration, and repeated at least once to enable observations of linearity and repeatability trends of the indicating-recording system.

8.6 *Tire Temperature Measuring Equipment (Optional):*

8.6.1 Perform the calibration of the temperature measuring equipment indicating-recording system by the direct comparison with an appropriate temperature transducer standard. Make the comparison with the two systems in thermal equilibrium.

8.6.2 Make the calibration at values throughout the range of temperatures normally experienced during the test. The intervals chosen should be small enough, of sufficient duration, and repeated at least once to enable observations of linearity and repeatability trends of the indicating-recording system.

NOTE 2—In Section 8, the phrase “repeated at least once” shall be interpreted to mean that the entire calibration procedure is repeated from beginning to end. Merely taking two duplicate readings in succession of each specified condition does not constitute a replication of the process of calibration.

9. Keywords

9.1 durability; endurance; laboratory tire testing; structural fatigue; testing tires

ASTM International takes no position respecting the validity of any patent rights asserted in connection with any item mentioned in this standard. Users of this standard are expressly advised that determination of the validity of any such patent rights, and the risk of infringement of such rights, are entirely their own responsibility.

This standard is subject to revision at any time by the responsible technical committee and must be reviewed every five years and if not revised, either reapproved or withdrawn. Your comments are invited either for revision of this standard or for additional standards and should be addressed to ASTM International Headquarters. Your comments will receive careful consideration at a meeting of the responsible technical committee, which you may attend. If you feel that your comments have not received a fair hearing you should make your views known to the ASTM Committee on Standards, at the address shown below.

This standard is copyrighted by ASTM International, 100 Barr Harbor Drive, PO Box C700, West Conshohocken, PA 19428-2959, United States. Individual reprints (single or multiple copies) of this standard may be obtained by contacting ASTM at the above address or at 610-832-9585 (phone), 610-832-9555 (fax), or service@astm.org (e-mail); or through the ASTM website (www.astm.org). Permission rights to photocopy the standard may also be secured from the Copyright Clearance Center, 222 Rosewood Drive, Danvers, MA 01923, Tel: (978) 646-2600; http://www.copyright.com/