



Standard Practice for Subsurface Installation of Corrugated Polyethylene Pipe for Agricultural Drainage or Water Table Control¹

This standard is issued under the fixed designation F449; the number immediately following the designation indicates the year of original adoption or, in the case of revision, the year of last revision. A number in parentheses indicates the year of last reapproval. A superscript epsilon (ϵ) indicates an editorial change since the last revision or reapproval.

1. Scope*

1.1 This practice is recommended for and limited to gravity flow subsurface drainage systems or water table control, but not recommended for sanitary or storm sewer applications. Procedures are outlined to minimize pipe deflection or structural damage during and after the installation process. These installation procedures are in accordance with “flexible conduit” principles.

1.2 This practice applies to all agricultural subsurface drainage or water table control installations using Specification F667, F2648, or other plastic pipe.

1.3 The values stated in inch-pound units are to be regarded as standard. The values given in parentheses are mathematical conversions to SI units that are provided for information only and are not considered standard.

1.4 *This standard does not purport to address all of the safety concerns, if any, associated with its use. It is the responsibility of the user of this standard to establish appropriate safety and health practices and determine the applicability of regulatory limitations prior to use.*

2. Referenced Documents

2.1 ASTM Standards:²

- D1600 Terminology for Abbreviated Terms Relating to Plastics
- D2412 Test Method for Determination of External Loading Characteristics of Plastic Pipe by Parallel-Plate Loading
- F412 Terminology Relating to Plastic Piping Systems
- F667 Specification for 3 through 24 in. Corrugated Polyethylene Pipe and Fittings
- F2648 Specification for 2 to 60 inch [50 to 1500 mm] Annular Corrugated Profile Wall Polyethylene (PE) Pipe

¹ This practice is under the jurisdiction of ASTM Committee F17 on Plastic Piping Systems and is the direct responsibility of Subcommittee F17.65 on Land Drainage.

Current edition approved Feb. 15, 2016. Published March 2016. Originally approved in 1976. Last previous edition approved in 2014 as F449 – 02(2014). DOI: 10.1520/F0449-16.

² For referenced ASTM standards, visit the ASTM website, www.astm.org, or contact ASTM Customer Service at service@astm.org. For *Annual Book of ASTM Standards* volume information, refer to the standard’s Document Summary page on the ASTM website.

and Fittings for Land Drainage Applications

3. Terminology

3.1 Definitions are in accordance with Terminology F412 and abbreviations are in accordance with Terminology D1600, unless otherwise specified.

3.2 *backfill*—materials used to fill the trench following installation of the pipe and bedding.

3.3 *bedding*—material which provides stable bottom support for the pipe including the trench bottom groove support angle or select material placed around the pipe, and envelope or filter materials where used during installation.

3.4 *blinding*—the placement of soil, bedding material over and on the sides of the pipe or envelope to ensure proper grade, alignment, support, and protection of pipe during backfilling and after installation.

3.5 *boot (also shield)*—the protecting apparatus linked to the rear of the installation machine in a manner which allows placement of the pipe on the trench bottom, protection of the workman, or placement of envelope or filter material, or both.

3.6 *cradle*—a prefabricated rigid structure designed to provide trench bottom support for the pipe when soil support is inadequate.

3.7 *envelope*—porous material placed around the pipe to provide bedding, improve the flow of ground water into the drain, or function as a filter.

3.8 *filter*—an envelope of natural or synthetic materials placed completely around a drain to permit free water movement into the drain, provide stabilizing support at the soil-filter interface, and restrict movement of silt and sand into the drain.

3.9 *grade*—the slope of the pipe invert.

3.10 *groove support angle*—angle between the radii of the pipe at points of contact with the formed groove of undisturbed soil or a cradle.

3.11 *mineral soils*—soil containing (1) less than 30 % organic matter by weight provided the mineral fraction is 60 % or more clay, or (2) less than 20 % organic matter by weight provided the mineral fraction has no clay, or (3) less than a proportional content of organic matter between 20 and 30 % if the clay content of the mineral fraction is between 0 and 60 %.

*A Summary of Changes section appears at the end of this standard

3.12 *natural granular envelope*—an envelope of granular material, usually highly permeable well-graded sand and gravel.

3.13 *organic soil*—soil containing (1) 30 % or more organic matter provided the mineral fraction is 60 % or more clay, or (2) 20 % or more organic matter provided the mineral fraction has no clay, or (3) a proportional content of organic matter between 20 and 30 % if the clay content of mineral fraction is between 0 and 60 %. (It is a general rule that a soil is classed as an organic soil (histosol) either if more than one half of upper 32 in. (80 mm) of soil is organic or if organic soil material of any thickness rests on rock or on fragmental material having voids filled with organic material.)

3.14 *pipe stiffness*—force per unit length, per unit deflection as defined in Test Method D2412.

3.15 *power feeder*—mechanism that applies force to the pipe as it passes through the boot or shield to reduce stretch during installation.

3.16 *pre-ripping*—the practice of making a pass with the plow without installing pipe to locate rocks and to reduce draft.

3.17 *semi-circular groove*—a rounded trench bottom in native *in situ* soil that conforms to the outside diameter from the invert to the springline of the pipe.

3.18 *start hole*—a trench sufficiently long and wide to allow working room for placing the boot or shield, blade or cutting mechanism on grade to start the trench and to install connections or pipe.

3.18.1 *Discussion*—Start holes are usually dug with a backhoe with a flat-bottom trench.

3.19 *stretch*—the increase in length of the pipe caused by tension forces during installation. It is expressed as a percent increase of the length prior to installation. Stretch differs from elongation in that elongation is a material test and stretch is an installation test.

3.20 *synthetic envelope*—an envelope made of synthetic geotextiles, usually thin synthetic fabrics or thicker fibrous material, or both, often selected to function as a filter.

3.21 *trench depth*—the depth of the trench measured from the bottom of the pipe.

3.22 *trench width*—the width of the trench measured at the top of the pipe.

3.23 Fig. 1 illustrates the terms bedding, vertical deflection, backfill material, cover, groove support angle, horizontal deflection, trench width, and trench depth.

Fig. 2a and b illustrates various support grooves or trench bottom shapes.

Fig. 3 illustrates envelope and filter.

Fig. 4 illustrates rodent protection devices.

Fig. 5 illustrates boot or shield.

4. General Requirements

4.1 *Burial*—The maximum and minimum burial depth are affected by the following factors, groove support angle or shape of the trench bottom, bedding, blinding backfill soil

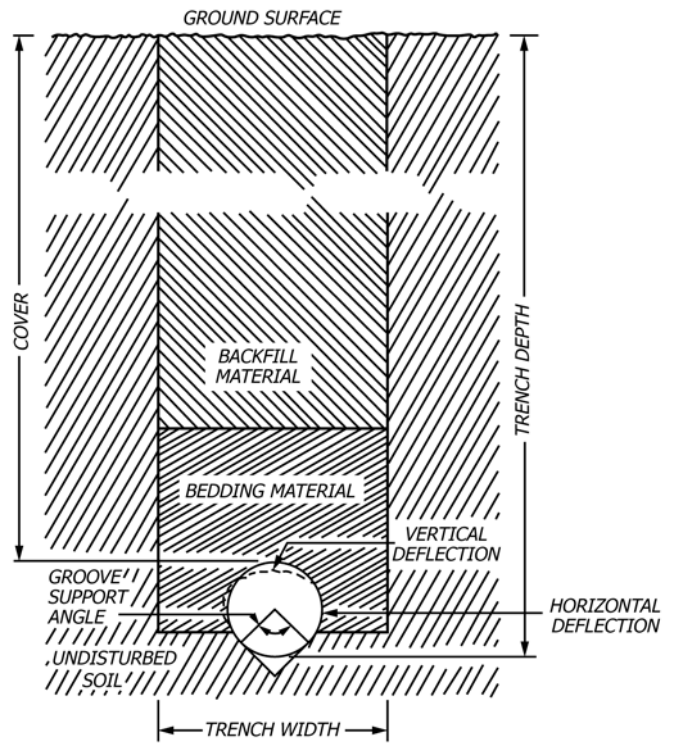

FIG. 1 Terminology for Installation of Plastic Drain Pipe

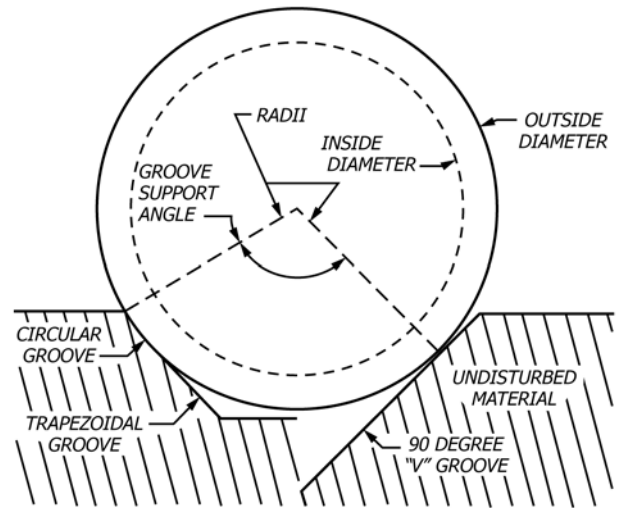

FIG. 2 a Support Grooves

density, envelope density, envelope placement, pipe stiffness, the live load expected, desired water table depth, and width of trench.

4.1.1 Minimum Depth:

4.1.1.1 *Mineral Soils*—The minimum recommended cover needed to protect the pipe from crushing under live loads is 2 ft (0.6 m). Granular bedding or special construction techniques may be used to reduce the cover. The time for consolidation of backfill may be a factor (see 8.1). The minimum cover may have limiting factors other than crushing such as clearance for subsiding and utility crossing

4.1.1.2 *Organic Soils*—Subsurface drains should be installed in these soils only after initial subsidence has occurred.

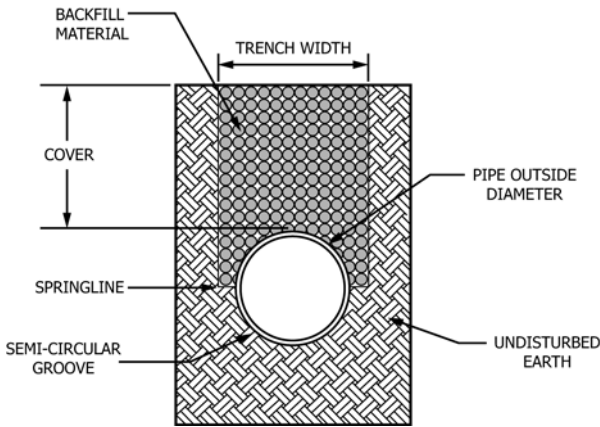

FIG. 2 b Semi-Circular Trench Groove (continued)

Without an engineering design, maximum buried depths should be limited to those listed in Table 1 or Table 2. For installation at depths greater than those listed in Table 1 or Table 2, specifications of and engineering design should be followed.

4.1.3 *Trench Width*—Increasing the trench width increases the soil load on the pipe. Side clearances of more than 150 mm (6 in.) on each side should only be used with an engineering design and special construction (see Table 1). For Table 1 designs, the trench width must be at least 50 mm (2 in.) wider than the pipe on each side for plow installation and 75 to 150 mm (3 to 6 in.) on each side for open trench installation to allow sufficient bedding to support the pipe. If fine material cannot be placed alongside and over the pipe, a wider trench should be considered or special bedding material supplied. For Table 2 designs, a maximum and minimum trench width is specified to limit excessive deflection and allow a larger amount of soil arching to reduce the load on the pipe. The tile boot or trench box used to construct the semi-circular groove shall conform as closely as possible to pipe OD and shall be within 1% or 1/2 in. (12 mm), whichever is greater, of the pipe OD. The trench width requirements only pertain to the vertical distance from the springline to the top of the pipe. It is permissible for the trench width above the top of the pipe to slope to the natural angle of repose of the soil.

NOTE 2—A narrow trench width will result in a greater transfer of loads to the sidefill materials. A semi-circular groove installation in insitu soils conforming to the outer diameter of the pipe minimizes the impact of poor compaction or installation techniques and provides very good bedding support in addition to reduced dead loads on the pipe.

4.2 *Design Items*—It is particularly important that blinding, bedding, or envelope material be placed as the pipe is installed, to ensure uniform continuous support, so that the bedding, blinding, or envelope material can provide lateral restraint against pipe deflection as the backfill settles on the bedding, blinding, or envelope material.

4.3 *Envelopes*—Must be designed to provide adequate support for the pipe, improve the flow of ground water into the pipe, and in some installations, filter flow into the pipe.

4.3.1 *Natural Granular Envelopes*—Minimum thickness of 75 mm (3 in.) around the pipe.

4.3.2 *Synthetic Envelopes*—Blinding or bedding is needed to support and hold the envelope and pipe in place.

4.4 *Filters*—Are required when ground water can develop velocities sufficient to move sand or silt, or both, into the drain. Filters must be able to restrict the movement of these particles into the pipe so that the hydraulic capacity of the pipe is maintained.

4.4.1 *Granular Filters*—Design of a graded sand and fine gravel filter should match the gradation of the specific soil following criteria developed by the Natural Resource Conservation Service, the U.S. Bureau of Reclamation, or the U.S. Army Corps of Engineers.

4.4.2 *Synthetic Filters*—Thin synthetic fabric material or geotextiles may be used where bedding, soil, and hydraulic conditions permit. The openings in synthetic filters must be compatible with the soil that surrounds the drain to prevent excessive movement of soil that otherwise could plug the drain or filter (see 5.3).

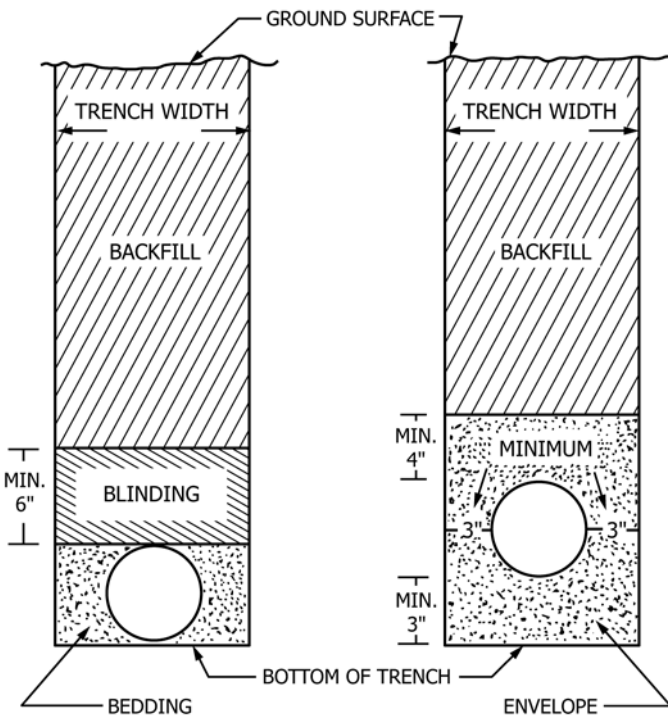

FIG. 3 Pipe Encased in Bedding for Support (left) and Pipe Encased in Sand and Gravel Envelope Designed as Filter (right)

To produce initial subsidence open ditches should be constructed in deep organic soils to carry off free water, and the area should be allowed to stand or be partially cultivated for a period of 3 to 5 years before installing pipe. The recommended minimum cover for the pipe in organic soils is 2.5 ft (0.7 m). If water level controls are not provided in the drainage system to hold subsidence to a minimum, the depth of cover should be increased to 3 ft (0.9 m).

NOTE 1—These minimum depths are recommended to prevent crushing of the pipe by normal agricultural vehicle loads. Other drainage factors such as those encountered with salinity control in arid irrigated lands may require minimum depths of 6 ft (1.8 m).

4.1.2 *Maximum Depth*—The maximum burial depth is influenced by such factors as degree of compaction, type of bedding, support from the trench bottom, trench width, size of pipe, pipe stiffness, weight of backfill, and live loads imposed.

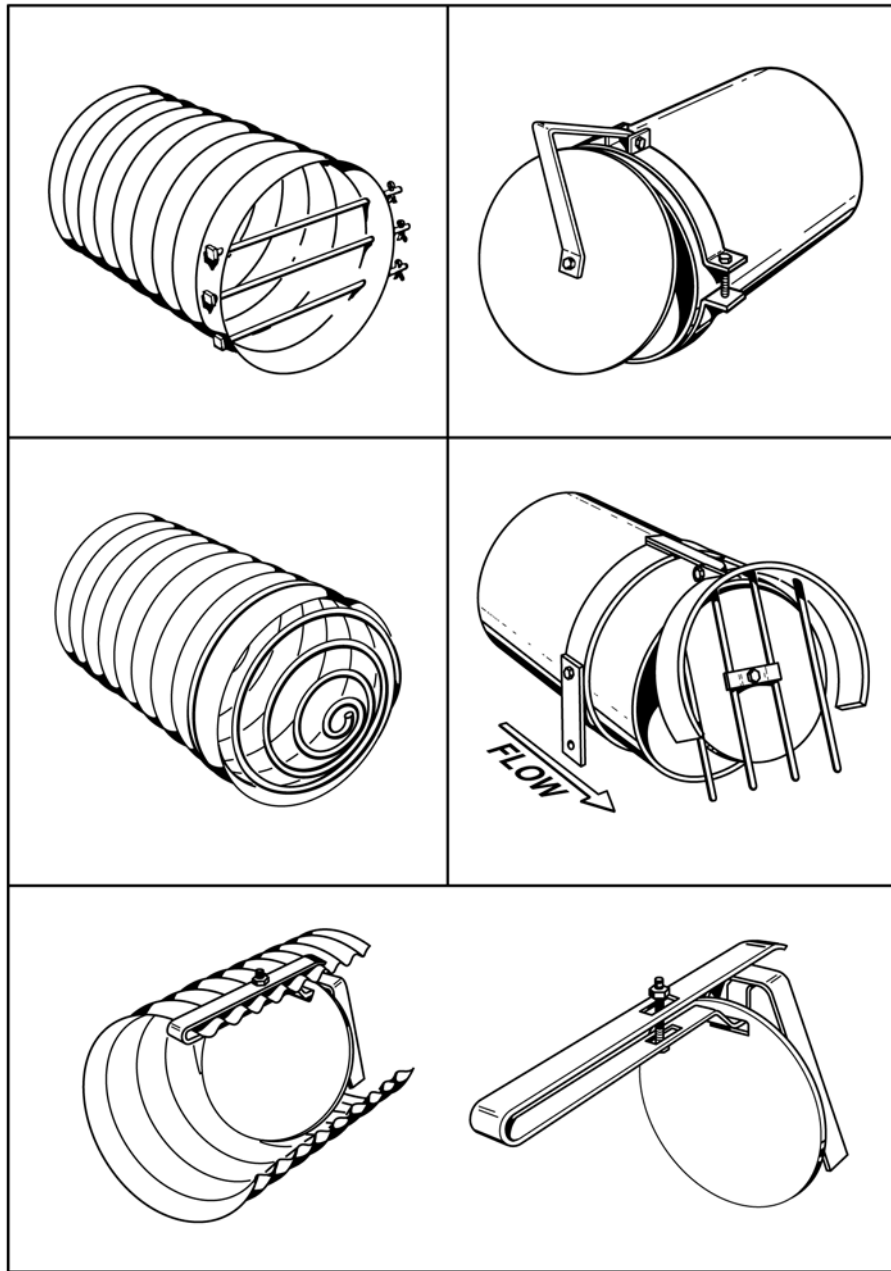

FIG. 4 Suggested Methods of Providing Rodent Protection for Outlet Pipes

NOTE 3—These filters must be specified to be compatible with the soil type that encompasses the conduit since protective filters can plug and decrease the inflow capability. Where fiberglass filter material is used, it shall be manufactured from borosilicate-type glass and the manufacturer shall certify that it is suitable for underground use. The fibers should be of variable size, with some larger fibers intertwined in the mat in a random manner.

NOTE 4—Vegetative filter material such as straw, hay, corn-cobs, woodchips, sawdust, and coconut fiber are not recommended for use with flexible conduits because such conduits depend on the development of lateral support and these soft materials may not provide the necessary lateral support.

4.5 *Grade*—Shall be as specified in the plan or guide. Deviations greater than the following shall not be allowed. Vertical deviations of more than 0.1 ft (30.5 mm) in 10 ft (3.05 m). Negative grade that would fill the pipe more than 10 %.

Due to the speed of installation with the plow, automatic grade control is recommended. The pipe feeding system shall hold the pipe in place in the bottom of the trench until secured by the bedding, blinding, or envelope material.

4.6 *Material Requirements*—Pipe and fittings shall meet the requirements of the applicable ASTM standards referenced in Section 2, Table 1, and Table 2.

5. Significant Factors in Pipe/Soil Interactions

5.1 *Connections*—In start holes and adjacent open trenches, the pipe shall be aligned both vertically and horizontally, blinded and hand tamped along the sides of the pipe to prevent excessive deflection.

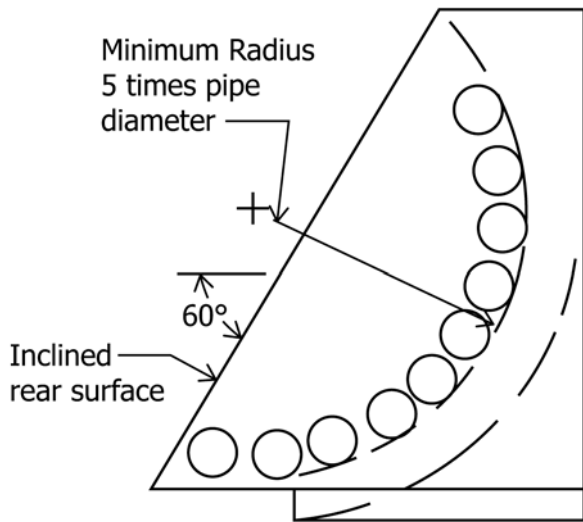

NOTE 1—This boot design has 60° inclined rear surface for transporting blinding material to the subsurface drain pipe and minimum bend radius for pipe.

FIG. 5 Example Boot Design

TABLE 1 Maximum Trench Depths for Pipe Buried in Loose, Fine-Textured Soils, ft (m)^A

NOTE 1—These depths are based on limited research and should be used with caution. Differences in commercial pipe from several manufacturers, including corrugation design and pipe stiffness and soil conditions, may change the assumptions; and, therefore, maximum depths may be more or less than stated above.

Nominal pipe diameter, in. (mm)	Pipe quality (ASTM)	Trench width at top of pipe, m (ft) ^A			
		0.3 (1)	0.4 (1.3)	0.6 (2)	0.8 (2.6) or greater
4 (102)	Standard ^B	3.9 (12.8)	2.1 (6.9)	1.7 (5.6)	1.6 (5.2)
	Heavy-Duty ^C	^D	3.0 (9.8)	2.1 (6.9)	1.9 (6.2)
6 (152)	Standard ^B	3.1 (10.2)	2.1 (6.9)	1.7 (5.6)	1.6 (5.2)
	Heavy-Duty ^C	^D	2.9 (9.5)	2.0 (6.6)	1.9 (6.2)
8 (203)	Standard ^B	3.1 (10.2)	2.2 (7.2)	1.7 (5.6)	1.6 (5.2)
	Heavy-Duty ^C	^D	3.0 (9.8)	2.1 (6.9)	1.9 (6.2)
10 (254)	^C	...	2.8 (9.2)	2.0 (6.6)	1.9 (6.2)
12 (305)	^C	...	2.7 (8.9)	2.0 (6.6)	1.9 (6.2)
15 (381)	^C	2.1 (6.9)	1.9 (6.2)
18 (457)	^C	2.1 (6.9)	1.9 (6.2)

^A E' = 345 kN/m² (50 psi)

D₁ = 3.4

K = 0.096 (90° bedding angle)

w = 1750 kg/m³ (109 lb/ft³)

Y = 1.1x (x = horizontal deflection)

^B Pipe stiffness 90 kN/m² (13 psi) for 20 % deflection.

^C Pipe stiffness 124 kN/m² (18 psi) for 20 % deflection.

^D Any depth is permissible for this or less width and for 0.2-m (0.67-ft) trench width for all sizes.

5.2 Deflection—The deflection of corrugated plastic pipe is related to installation practice, bedding, groove support angle, blinding, gradation and density of soil, depth of installation, trench width in relation to pipe size, live loads imposed, stretch, and pipe stiffness of pipe. Maximum pipe deflection should be specified and not exceed 10 % of its nominal diameter.

TABLE 2 Maximum Trench Depths for Pipe Buried with a Semi-Circular Groove, ft (m)^A

NOTE 1—These depths are based on limited research and should be used with caution. Differences in commercial pipe from several manufacturers, including corrugation design and pipe stiffness and soil conditions, may change the assumptions; and, therefore, maximum depths may be more or less than stated above.

Nominal Pipe Inside Diameter in. (mm)	Typical Pipe Outside Diameter in. (mm)	Trench Width at Springline of Pipe in. (mm)	Tolerance on Trench Width at Springline in. (mm)	Maximum Depth of Fill ft (m)
10 [250]	12 [305]	16 [406]	+ 8 [+ 203]	11 [3.4]
12 [300]	15 [381]	19 [483]	+ 12 [+ 305]	11 [3.4]
15 [375]	18 [457]	22 [559]	+ 12 [+ 305]	10 [3.0]
18 [450]	21 [533]	25 [635]	+ 12 [+ 305]	10 [3.0]
24 [600]	28 [711]	32 [813]	+ 12 [+ 305]	10 [3.0]
30 [750]	35 [889]	39 [991]	+ 16 [+ 406]	10 [3.0]
36 [900]	41 [1041]	45 [1143]	+ 18 [+ 457]	8 [2.4]
42 [1050]	48 [1219]	52 [1321]	+ 20 [+ 508]	8 [2.4]
48 [1200]	54 [1371]	58 [1473]	+ 20 [+ 508]	7 [2.1]
60 [1500]	67 [1702]	71 [1803]	+ 25 [+ 635]	6[1.8]

^A A small “V” notch or groove at the bottom of the shaped trench may be beneficial to accommodate any soil chunks or small clods that may fall into the plowed-in or excavated trench in order to prevent localized stress points on the invert crown of the pipe.

5.3 Filters—Synthetic materials should never be used when the soil has a silt content greater than 40 %.

5.4 Trench Depth—See 4.1.

5.5 Trench Width—The width of the trench or blade below the top of the pipe should be adequate to allow placing pipe, reducers, and connectors in the bottom of the trench and should conform to 4.1.3.

6. Construction

6.1 Alignment—Should be as smooth as possible with a curve radius larger than five times the pipe diameter.

6.2 Backfilling—Place the backfill material so that displacement or deflection of the pipe will not occur. This is preferably on an angle, so the material flows down the front slope. Avoid large stones, frozen material, and dry clods that cause concentrated direct loads on the pipe. The trench should be backfilled as soon as possible after blinding. When installing the pipe on a hot day back-filling should be delayed until pipe temperature cools to the soil temperature (see 8.1).

6.3 Bedding—Necessary for the support and protection of the pipe. If adequate support is not provided by the soil and trench bottom shape as shown in Fig. 2a or Fig. 2b, envelopes or special construction should be used.

6.4 Blinding—Material used for this process should not contain any hard object larger than 38 mm (1 1/2 in.) in diameter and should cover the pipe to a depth of 150 mm (6 in.). See Fig. 5 for possible boot and shield configuration.

6.5 Bottom Shape—The bottom should be one of the shapes shown in Fig. 2a or Fig. 2b. The 90° “V” bottom of Fig. 2 works well on nominal sizes less than 200 mm (8 in.). The pipe is pressed into the void, which reduces horizontal deflection in the completed installation. For pipe 200 mm (8 in.) or greater, the circular, trapezoidal groove or shaped trench bedding

should be used. The curve of the circular groove or shaped trench bedding shall closely fit the outside of the pipe or there will be insufficient support and deflection will be increased. For flat-bottom trench, bedding must be used for support as in Fig. 3.

6.6 *Couplers, Fittings, and Curves*—Fittings should be installed in accordance with instructions furnished by the manufacturer. Couplers should be used to connect pipe together. Fittings should be used at all changes in direction where the centerline radius is less than five times the pipe diameter, changes in diameter, and junctions with another line. All fittings shall be compatible with the pipe. Where certain fittings are not available, hand-cut holes are acceptable, provided care is taken when making the connection not to create a means of obstructing flow, catching debris, or allowing soil to enter the drain.

6.7 *End Caps*—End caps or end plugs must be installed on the termination of each line.

NOTE 5—Bending of corrugated pipe creates tension in the pipe wall on the outside of the curve. Avoid pipe boots with less than five times the diameter radius. Avoid press wheels and slides that place the pipe on the bottom of the trench in a bent or stretched condition.

6.8 *Grade*—Equipment operating on uneven ground surfaces should use a grade control system capable of maintaining the specified depth and grade. Automatic grade control is recommended, using a ground speed that allows the control system to function properly.

6.9 *Over-Excavation*—Fill any area of over-excavation below the grade line with proper bedding material. Plane and shape the pipe bed to grade. For drainage of irrigated lands, backfill over-excavated portions of the trench with a designed gravel envelope material with adequate hydraulic conductivity to allow water movement into the pipe openings.

6.10 *Rock Excavation*—When the pipe is to be laid in a rock cut, the trench should be over-excavated to a depth of 150 mm (6 in.) below grade and the over-excavation filled to grade with suitable bedding to provide a firm foundation (see 6.9). The balance of the trench within the rock cut should be filled with designed bedding or envelope material.

6.10.1 *Stony Trench*—Remove stones larger than 38 mm (1½ in.) in the trench bottom. Any over-excavation should be treated as in 6.9. Inspection should also be made to locate stones pushed aside by the plow that have fallen back against the pipe causing deflection.

6.11 *Safety*—Provision for safety of all operations shall be in compliance with applicable safety and health regulations.

6.12 *Special Problems:*

6.12.1 *Backfilling*—Most plow installations require a minimum of backfilling, yet care must be taken to ensure that the trench is filled and bridging does not occur. Open trenches should be overfilled to allow consolidation, or the backfill should be compacted to reduce the amount of settling.

6.12.2 *Granular Envelope Placement*—Take care to prevent separation or inclusion of nonspecified material.

6.12.3 *Start Hole*—Take special care to provide bedding, blinding, or envelope material to prevent excessive deflection (see Fig. 3). Manufactured fittings should be used (see 6.7).

6.12.4 *Preripping*—May be advisable in order to locate stones or other large unacceptable objects or problem areas and to lower the tractive effort in the installation pass.

6.12.5 *Unstable Soil*—Where unstable trench or non-cohesive soil conditions are encountered, such as fine sandy soils or quicksand, extreme care must be taken to keep this material from entering the pipe and to ensure adequate support. Blinding must be done immediately as the pipe emerges from the boot or shield to prevent floating, movement, or deformation of the pipe resulting from soil caving. Steady but continuous speed should be used, as stopping will usually cause a grade deviation. Following 6.12.5.1 through 6.12.5.5 may be helpful when draining these soils.

6.12.5.1 *Foundation Cradle*—Where stabilizer materials do not provide adequate support, pipe should be placed in a 90° rigid “V” prefabricated foundation cradle. The cradle must provide rigidity and furnish continuous support throughout the entire length.

6.12.5.2 *Dry Profile*—Install pipe when soil profile is in the driest condition possible. A temporary drain may be advisable in some conditions to lower the water table before installation.

6.12.5.3 *Foundation*—If a significant depth of unstable soil material is encountered at the foundation level, it should be removed and replaced with suitable bedding material. The depth of bedding will depend on the severity of the unstable soil. Install the bedding in a maximum of 150-mm (6-in.) compacted layers (see 6.9).

6.12.5.4 *Noncohesive Soil*—Pockets of noncohesive soil will need special construction to maintain grade and provide adequate support. Examples of special construction are non-perforated pipe, suitable envelope material or filter to prevent soil infiltration. Bedding or a cradle may also be needed to maintain grade.

6.12.5.5 *Organic Soil*—Organic soil is generally unstable and will not support the shoe of the trencher or the floating beam plow without special operating procedures.

7. Handling of Pipe

7.1 *High Temperature*—Results in a loss of pipe stiffness in the pipe. Special care must be exercised during installation on a hot sunlit day, as black pipe can become much warmer than the air temperature. The resulting loss of pipe stiffness may allow extra stretch and even deflection collapse of the pipe. Non-black pipe will not absorb as much sunlight and should be considered. Stringing the pipe immediately prior to placing it in the ground can reduce the solar heating. The pipe will regain its pipe stiffness in less than 5 min after installation.

7.2 *Low Temperature*—The stiffness of the pipe increases as the temperature decreases. At temperatures below 6°C (45°F), rapid uncoiling may crack the pipe. The pipe may have a tendency to return to the coiled configuration at these temperatures which will require extra care while bedding and blinding to maintain line and grade.

7.3 *Stretch*—May be caused by tension and bending forces in the installation process. Stretch occurring during installation may cause some decrease in pipe stiffness, couplings may be pulled apart, and perforated pipe openings may be pulled open wider than desirable. Pipe should not be stretched so that pipe

stiffness is reduced to less than the allowable minimum. Stretch during installation should not exceed 5 %.

NOTE 6—The amount of drag as the pipe feeds through the boot should be minimized. Power feeders are often used to control stretch during installation.

7.4 *Synthetic Envelopes and Filters*—Some of these materials are thin and subject to abrasion and tearing during handling. Special care must be taken to ensure complete coverage during installation. Damaged portions should be repaired or replaced. Sunlight will rapidly degrade some of these materials and they must be protected if stored for longer periods than the manufacturer.

7.5 *Storage*—Corrugated plastic pipe will burn and must be protected from fire hazard. Coils of pipe should be stored on a flat smooth surface free of stones or other items which may damage the pipe. During storage, the ends of the pipe should be capped to prevent birds, animals, or foreign material from entering the pipe. Any damage during storage must be repaired before installation. Excessive (two years or more) exposure to ultraviolet rays from sunlight can be harmful to pipe. Pipe stored for more than two years should be tested or inspected for brittleness, damage, external clogging, or internal debris before installation.

8. System Protection

8.1 *Early Use Damage*—Pipe installed at near minimum depths and without gravel envelope or special construction should be protected from livestock and heavy wheel traffic, while the newly constructed backfill is loose. Consolidation of the backfill may take as long as six months.

8.2 *Outlet Pipe*—A length of rigid or semi-rigid nonperforated pipe, as specified, should be used as an outfall of subsurface drains. Corrugated plastic pipe should not be used as an outlet pipe if exposed to sunlight, fire, livestock, or equipment. Where backflow of surface water is possible, hinged gates should be used (see Fig. 4). The projection of the outlet pipe from the bank should be as little as possible and not

more than one third the length, to provide the required support. The connection of a minimum of 3 m (10 ft) of nonperforated pipe should be sealed to the outlet pipe to prevent seepage under the outlet pipe.

8.3 *Rodent Protection*—The outlet should be equipped with an animal guard to protect the system from entry and damage by rodents or other animals (see Fig. 4). Where pipe is connected to old tile lines that may serve as animal runs, an animal guard should be installed within the line to restrict animal travel.

NOTE 7—Automatic flap gates, rods, or similar protection should be used on all drain outlets to exclude small animals unless the outlet is so located that it would be impossible for them to enter the drain (Fig. 4). No fixed bar or other type grating shown in this figure should be used where direct entry of surface water or any type debris is possible. Gates should be used in these cases.

8.4 *Tree Roots*—Use nonperforated pipe when passing through areas where root growth may create an obstruction in the line.

NOTE 8—Nonperforated pipe should be used at locations where the line is within 30 m (100 ft) of lowland or water-loving type of trees such as willows, elms, and cottonwoods and within 15 m (50 ft) of such species as hardwoods, fruit, and nut trees.

9. Standard Clauses

9.1 *Responsibility for Inspection*—Unless otherwise specified in the contract or purchase order, the contractor is responsible for the performance of all inspection and installation requirements specified herein, unless disapproved by the purchaser or client. The purchaser shall have the right to perform any of the inspections and evaluate installation procedures set forth in this specification, where such inspections are deemed necessary to ensure the installation conforms to prescribed requirements.

NOTE 9—In U.S. Federal contracts, the contractor is responsible for inspection.

NOTE 10—The inclusion of U.S. Government procurement requirements should not be construed as an indication that the U.S. Government uses or endorses the products described in this practice.

SUMMARY OF CHANGES

Committee F17 has identified the location of selected changes to this standard since the last issue (F449 – 02(2014)) that may impact the use of this standard.

(1) Addition of the semi-circular groove installation detail with associated fill height table.

(2) Deletion of Specification F405 (withdrawn) and the inclusion of Specification F2648 products.

ASTM International takes no position respecting the validity of any patent rights asserted in connection with any item mentioned in this standard. Users of this standard are expressly advised that determination of the validity of any such patent rights, and the risk of infringement of such rights, are entirely their own responsibility.

This standard is subject to revision at any time by the responsible technical committee and must be reviewed every five years and if not revised, either reapproved or withdrawn. Your comments are invited either for revision of this standard or for additional standards and should be addressed to ASTM International Headquarters. Your comments will receive careful consideration at a meeting of the responsible technical committee, which you may attend. If you feel that your comments have not received a fair hearing you should make your views known to the ASTM Committee on Standards, at the address shown below.

This standard is copyrighted by ASTM International, 100 Barr Harbor Drive, PO Box C700, West Conshohocken, PA 19428-2959, United States. Individual reprints (single or multiple copies) of this standard may be obtained by contacting ASTM at the above address or at 610-832-9585 (phone), 610-832-9555 (fax), or service@astm.org (e-mail); or through the ASTM website (www.astm.org). Permission rights to photocopy the standard may also be secured from the Copyright Clearance Center, 222 Rosewood Drive, Danvers, MA 01923, Tel: (978) 646-2600; <http://www.copyright.com/>