



Standard Specification for Roof and Rock Bolts and Accessories¹

This standard is issued under the fixed designation F432; the number immediately following the designation indicates the year of original adoption or, in the case of revision, the year of last revision. A number in parentheses indicates the year of last reapproval. A superscript epsilon (ϵ) indicates an editorial change since the last revision or reapproval.

1. Scope*

1.1 This specification covers the chemical, mechanical, and dimensional requirements for roof and rock bolts and accessories. Addressed in this specification are double-end threaded and slotted steel bars; fully grouted bolts and threaded bars; mechanical anchorage devices used for point anchorage applications; roof truss systems; partially grouted deformed bolts; formable anchorage devices; cable bolt systems; expandable rock bolts and other frictional anchorage devices. All of these products represent various designs used for ground support systems. This specification can be revised to address new technologies.

1.2 The values stated in inch-pound units are to be regarded as standard. No other units of measurement are included in this standard.

1.3 This hazard statement applies only to Section 10, Test Methods of this specification. *This standard does not purport to address the safety concerns, if any, associated with its use. It is the responsibility of the user of this standard to establish appropriate safety and health practices and determine the applicability of regulatory limitations prior to use.*

2. Referenced Documents

2.1 ASTM Standards:²

- A29/A29M Specification for General Requirements for Steel Bars, Carbon and Alloy, Hot-Wrought
- A47/A47M Specification for Ferritic Malleable Iron Castings
- A194/A194M Specification for Carbon and Alloy Steel Nuts for Bolts for High Pressure or High Temperature Service, or Both
- A220/A220M Specification for Pearlitic Malleable Iron
- A370 Test Methods and Definitions for Mechanical Testing of Steel Products

¹ This specification is under the jurisdiction of ASTM Committee F16 on Fasteners and is the direct responsibility of Subcommittee F16.02 on Steel Bolts, Nuts, Rivets and Washers.

Current edition approved May 1, 2013. Published July 2013. Originally approved in 1975. Last previous edition approved in 2010 as F432 –10. DOI: 10.1520/F0432-13.

² For referenced ASTM standards, visit the ASTM website, www.astm.org, or contact ASTM Customer Service at service@astm.org. For *Annual Book of ASTM Standards* volume information, refer to the standard's Document Summary page on the ASTM website.

- A416/A416M Specification for Steel Strand, Uncoated Seven-Wire for Prestressed Concrete
- A536 Specification for Ductile Iron Castings
- A563 Specification for Carbon and Alloy Steel Nuts
- A615/A615M Specification for Deformed and Plain Carbon-Steel Bars for Concrete Reinforcement
- A882/A882M Specification for Filled Epoxy-Coated Seven-Wire Prestressing Steel Strand
- A1011/A1011M Specification for Steel, Sheet and Strip, Hot-Rolled, Carbon, Structural, High-Strength Low-Alloy, High-Strength Low-Alloy with Improved Formability, and Ultra-High Strength
- A751 Test Methods, Practices, and Terminology for Chemical Analysis of Steel Products
- D6637 Test Method for Determining Tensile Properties of Geogrids by the Single or Multi-Rib Tensile Method
- D1248 Specification for Polyethylene Plastics Extrusion Materials for Wire and Cable
- F436 Specification for Hardened Steel Washers
- F606 Test Methods for Determining the Mechanical Properties of Externally and Internally Threaded Fasteners, Washers, Direct Tension Indicators, and Rivets

2.2 ASME Standards:³

- B 1.1 Unified Screw Threads
- B 1.3M Screw Thread Gaging Systems for Dimensional Acceptability—Inch and Metric Screw Threads
- B 18.2.2 Square and Hex Nuts

3. Terminology

3.1 Definitions:

3.1.1 *barrel*—a device housing normally either 2 or 3 piece cable strand wedges

3.1.2 *bearing plates, plate washers, mine roof plates*—plates that serve to distribute the load from the exposed end of the bolt or threaded bar to the rock face or intermediate member.

3.1.2.1 *header plates*—large rectangular bearing plates, usually 6 in. wide by 16 to 18 in. long, or any other shape with an equivalent area, used in substitution for wooden header blocks

³ Available from American Society of Mechanical Engineers (ASME), ASME International Headquarters, Three Park Ave., New York, NY 10016-5990, <http://www.asme.org>.

*A Summary of Changes section appears at the end of this standard

for wider distribution of the bolt load than is possible with standard bearing plates.

3.1.3 *bendable bolts*—bolts furnished with an altered section at some location, to be specified by the customer, at which the bar will bend.

3.1.3.1 *Discussion*—Bending is necessary to permit installation of bars longer than the mine opening height. This altered section may be produced by hot or cold forging, or by shearing, sawing, trimming, machining, grinding, or a combination of these processes.

3.1.4 *beveled washers*—washers whose faces are at an angle permitting a headed bolt or threaded bar to be installed at a slight angle to the rock face and yet maintained the face of the bolt head perpendicular to the bolt axis.

3.1.5 *cable bolt*—cable strand with an assembly placed on the end for installation and load resistance purposes.

3.1.6 *chemical anchors*—chemical materials that provide anchorage between the bolt or bar and the drilled hole.

3.1.7 *discontinuous turn*—discontinuous turn shall include material heat changes, interruptions to the manufacturing operation exceeding 8 hrs, and significant machinery adjustments that materially alter the manufacturing process. The discontinuous turn shall apply to all separate manufacturing stations separate from the material heat change criteria. A material length change will not constitute a “discontinuous turn” as provided in this definition.

3.1.8 *expandable rock bolt*—rock support device that consists of a steel tube, folded or collapsed on itself, that can be inserted into a borehole and expanded, by means of high internal pressure, against the wall of the borehole. The product anchorage is developed through a combination of friction and mechanical interlock of the expanded profile against the borehole wall after the internal expansion pressure used for installation has been relieved.

3.1.9 *expansion shells*—anchorage devices that, separate from the bar or bolt, mechanically expand to grip the sides of a drilled hole and transfer load between the location of the anchor to the bar or bolt.

3.1.10 *extensions*—threaded bars used to extend the length of threaded or threaded slotted bars.

3.1.11 *formable anchorage devices*— any roof support devices that provide anchorage through some means of physical interference and engagement of the surface of a bar or bolt with any formable material, other than chemical grout, in a borehole.

3.1.12 *frictional anchorage devices*—ground support devices, friction stabilizers, that are designed so that the holding force/anchorage is generated by frictional forces between the surface of the borehole and the surface of the device. The frictional forces can be active over the full or partial length of the device.

3.1.13 *fully grouted bolts and threaded bars*—deformed bars or plain bars used with full-length grouting and having special deformations or other design features to provide interlocking between the steel and the grout.

3.1.14 *hardened washers*—washers that have been hardened by heat treatment to provide consistency to the torque tension relation necessary to control installation tension of bolts and threaded bars.

3.1.15 *minimum non-seizure load (MNSL)*—the load level in pounds through which bolt/plug thread seizure must not occur.

3.1.16 *minimum ultimate load (MUL)*—the load level in pounds through which bolt/plug thread failure must not occur.

3.1.17 *rollers, cams*—moving devices that, when used with internally threaded cylinders containing external tapered slots, provide expansion to grip the sides of a drilled hole mechanically and transfer load from the location of the anchor to the bar or bolt.

3.1.18 *roof and rock bolts*—headed hot-rolled bars with cold-rolled or machine-cut threads at the end, to be used with anchorage devices to hold up mine roofs, hold back walls, or hold down equipment or foundations.

3.1.19 *roof truss system*—a roof support system incorporating bolts that are joined together by crossmember(s) that is (are) tensioned by design.

3.1.20 *strand*—a group of wires normally having helically placed outer wires with uniform pitch.

3.1.21 *spherical washers or seats*—washers that are flat on one side and have a spherical face on the other side. The combination of spherical washer together with a depression in the bearing plate produces a ball-and-socket joint permitting bolts to be installed at a slight angle to the rock face while still maintaining the face of the bolt head perpendicular to the bolt axis.

3.1.22 *tapered wedges*—plain wedges that provide the expansion for threaded slotted bars.

3.1.23 *tension nuts*—nuts that are intended to induce and maintain tension in a bolt.

3.1.24 *threaded bars*—bars that are used with a nut on one end and an anchorage device on the other. They are used in a manner similar to the bolts described in [3.1.18](#).

3.1.25 *threaded couplings*—couplings used to permit the assembly of additional externally threaded items.

3.1.26 *threaded slotted bars*—bars threaded at one end each with a forged, burned, or sawed slot at the other, into which a tapered wedge can be inserted. When each assembly is driven into a bottomed hole, the wedge spreads the slot and an anchorage is produced.

3.1.27 *threaded tapered plugs*—threaded wedge that expands the expansion shell by the movement of the threaded plug within the shell as tightening progresses.

3.1.28 *wedge*—pieces of tapered metal with teeth which bite into the strand under load.

3.1.28.1 *Discussion*—Two or three piece wedges are normally used.

4. Ordering Information

4.1 Orders for material under this specification shall include at least the following information:

4.1.1 Quantity (number of pieces),

4.1.2 Name of product together with description of accessories,

4.1.3 Dimensions,

4.1.4 ASTM designation and year of issue, including strength grade,

4.1.5 Special requirements, if any, including packaging and thread protection instructions, and

4.1.6 Certifications, if required.

4.2 The products covered by this specification are currently produced by many manufacturers to a wide variety of designs. It is necessary for the user and the manufacturer to establish the requirements of the individual installation and to agree as to the type of assembly to be employed. See [Annex A1](#) and [Appendix X1](#) for additional information.

5. Manufacturing Processes

5.1 *Materials for Bolts, Extensions, and Threaded or Threaded Slotted Bars:*

5.1.1 Steel shall conform to the requirements shown in [Table 1](#) and in Specification [A29/A29M](#) for plain bars or Specification [A615/A615M](#) for plain or deformed bars unless otherwise specified.

5.1.1.1 Threaded slotted bars may have the slot produced by forging, burning, or sawing. Burned slots of Grades 55 and 75 threaded slotted bars must have the slotted end normalized by heating to a minimum of 1600°F and air cooling subsequent to burning.

5.1.1.2 Threads on bolts or threaded bars may be cold rolled or machine cut on the hot-rolled bars.

5.1.2 Steel strands for use as cable bolts shall conform to Specification [A416/A416M](#).

5.1.3 Filled epoxy steel strands for use as cable bolts shall conform to Specification [A882/A882M](#).

5.2 *Materials for Tapered Wedges for Use With Threaded Slotted Bars:*

5.2.1 Malleable iron casting shall conform to Specification [A47/A47M](#).

5.2.2 Pearlitic malleable iron castings shall conform to Specification [A220/A220M](#), Grades 45006 or 50005.

5.2.3 Steel shall conform to the requirements shown in [Table 1](#).

5.3 *Materials for Expansion Shells:*

5.3.1 Malleable iron castings shall conform to Specification [A47/A47M](#).

5.3.2 Steel shall conform to the requirements shown in [Table 1](#).

5.3.3 Ductile iron castings shall conform to Specification [A536](#), Grades 60-40-18.

5.4 *Materials for Threaded Tapered Plugs Used with Expansion Shells:*

5.4.1 Materials for threaded tapered plugs used with expansion shells shall conform to the test specifications in [10.8](#).

5.5 *Materials for Bearing and Header Plates, Also Known As Plate Washers or Mine Roof Plates:*

5.5.1 Steel shall conform to the requirements shown in [Table 1](#).

5.5.1.1 Bearing and header plates may be strengthened by cold forming or may be hardened by quenching in a liquid medium from above the austenitizing temperature and tempering at a temperature of not less than 650°F.

5.6 *Materials for Spherical, Flat, or Beveled Hardened Washers:*

5.6.1 Steel shall conform to the requirements shown in [Table 1](#).

5.6.1.1 Hardened steel washers shall be through hardened by quenching in a liquid medium from above the austenitizing temperature and tempering at a temperature of not less than 650°F. Case-hardened washers are not permitted.

5.7 *Materials for Spherical or Beveled Washers:*

5.7.1 Malleable iron castings shall conform to Specification [A47/A47M](#).

5.7.2 Pearlitic malleable iron castings shall conform to Specification [A220/A220M](#), Grades 45006, 50005, or 60004.

5.7.3 Steel shall conform to the requirements shown in [Table 1](#).

5.8 *Materials for Nuts:*

5.8.1 Nuts shall be in accordance with Specifications [A194/A194M](#) or [A563](#). Appropriate nuts for each grade of threaded bar are shown in [Table 2](#). Higher strength nuts conforming to Specifications [A194/A194M](#) or [A563](#) may be substituted. When specified on the order or contract, nuts with external dimensions of nominal 3/4-in. heavy hex or heavy square size may be supplied with 5/8-in. threads for use with 5/8-in. threaded bars.

5.9 *Materials for Chemical Grouting Materials:*

5.9.1 Chemical grouting materials are covered in [Annex A3](#) of this specification.

TABLE 1 Chemical Requirements

Product	Carbon, max, %		Sulfur, max, %		Phosphorus, max, %	
	Heat	Product	Heat	Product	Heat	Product
Bolts, threaded bars, and threaded slotted bars ^A	0.75	0.79	0.13	^B	0.050	0.058
Steel tapered wedges	0.80	0.84	0.13	^B	0.050	0.058
Hardened spherical, flat, or beveled washers	0.80	0.84	0.050	0.058	0.050	0.058
Spherical or beveled washers	0.80	0.84	0.050	0.058	0.050	0.058
Bearing and header plates	1.00	1.04	0.050	0.058	0.050	0.058
Steel threaded tapered plugs	0.60	0.64	0.13	^B	0.050	0.058
Steel expansion shells	0.30	0.33	0.050	0.058	0.050	0.058

^A Bars furnished in accordance with Specification [A615/A615M](#) may be substituted for these requirements.

^B Check analysis for sulfur if a resulfurized steel is not technically appropriate.

TABLE 2 Appropriate Nuts

Bolt, Threaded Bar, or Threaded Slotted Bar Grade	Nut Specification
30 (regular strength)	A194/A194M , Grade 1; A563 , Grade B
55 (high strength)	A194/A194M , Grade 1; A563 , Grade B
75 (extra high strength)	A194/A194M , Grade 2; A563 , Grade C

5.10 Materials for Threaded Couplings:

5.10.1 Materials for threaded couplings shall be selected by the manufacturer to ensure compliance with 7.6 and 8.6.1.

5.11 Materials for Bolts and Threaded Bars for Use in Grouted Systems—Plain or deformed steel bars shall conform to Table 1 or Specification A615/A615M.

5.12 Materials for Friction Stabilizers—Sheet steel shall conform to requirements specified in Specification A1011/A1011M, Table 2 HSLAS Class 2 material per Table 3.

5.13 Materials for Truss Systems:

5.13.1 Components of roof truss systems shall be manufactured in accordance with the appropriate paragraph(s) of Section 5 of this specification.

5.14 Materials for Formable Anchors:

5.14.1 Materials for formable anchor tubes are as follows:

5.14.1.1 Polyethylenes used for formable anchor tubes shall conform to ASTM D1248 Classification Type III, Class A or B, Category 5.

NOTE 1—All shapes, compositions, and properties of formable anchor materials are not covered by this specification. Users must ensure that the formable anchor material offered is suitable for its intended use.

6. Chemical Composition

6.1 Materials used for bolts, threaded bars, threaded slotted bars, spherical, flat, or beveled washers, threaded tapered plugs, tapered wedges, expansion shells, bearing plates and roof truss components shall be as specified in Table 1 and Section 5.

6.2 Materials for all cast or wrought metallic items other than those covered in 6.1 shall conform to the requirements as specified in Section 5.

6.3 Individual heats of steel or cast iron are not identified in any of the finished products.

6.4 Chemical analyses for steel products shall be performed in accordance with Test Methods, Practices, and Terminology A751.

6.5 Materials for formable anchors shall conform to the requirements, if applicable, specified in Section 5.

6.6 Chemical analyses shall be performed in accordance with Test Methods, Practices, and Terminology A751.

6.7 Material for friction stabilizers shall conform to requirements specified in Specification A1011/A1011M, Table 2 HSLAS Class 2 material per Table 3.

TABLE 3 Mechanical Properties of Sheet Steel for the Manufacture of Friction Stabilizers

Designation ^A	Nominal Diameter, in. ^B	Minimum yield strength, psi ^C
33	1.33	60 000
39	1.54	60 000
46	1.81	50 000

^ADesignation denotes traditional reference to nominal millimeter diameter measurement as previously established.

^BAs measured across bolt diameter perpendicular to the slot as indicated in Fig. 7.

^CPer Specification A1011/A1011M.

7. Mechanical Properties

7.1 Mechanical properties of steel bars, for the manufacture of bolts, threaded bars, or threaded slotted bars shall be as specified in Table 4 for the required grade.

7.2 Mechanical properties of steel bolts, threaded bars, and threaded slotted bars whose slots have been produced without material removal shall be as specified in Table 5 for the required grade.

7.3 Expansion shells, threaded tapered plugs, tapered wedges, and spherical washers shall conform to the applicable specification of Section 5 and shall successfully perform the required purpose as described in Annex A1.

7.4 Bearing plates and header plates that are strengthened by quenching and tempering shall have a maximum hardness of 45 HRC.

7.4.1 Bearing plates and header plates shall be provided in 10 000-lbf grade increments. The minimum grade rating permitted shall be 20 000 lbf.

7.5 Hardened washers shall have a hardness range from 35 to 45 HRC.

7.6 Threaded couplings must be capable of developing the actual yield and tensile values of the bolt, threaded bar, or threaded slotted bar with which they are to be used.

7.7 Extensions must be in accordance with 7.1 and 7.2 for the grade of item specified.

7.8 Mechanical properties for bolts and threaded bars for use in grouted systems shall be as specified in Table 4 for plain bars; and Table 4 or Specification A615/A615M for deformed bars. Bolts and threaded bars made from plain material must contain some design feature to provide interlocking between the steel and the grout. These items can be supplied threaded or headed.

7.9 Threaded slotted bars whose slots have been produced by burning shall be heat treated by normalizing in accordance with 5.1.1. The normalizing heat treatment and the removal of material from the slot, whether it be by burning or sawing, will result in lower test values. When either the burning or sawing

TABLE 4 Mechanical Properties of Steel Bars for the Manufacture of Bolts, Threaded Bars, and Threaded Slotted Bars^{A,B}

Grade	Nominal Diameter, in. ^C	Yield Point min, psi	Tensile Strength min, psi	Elongation in 8 in. or 200 mm Minimum, %
40 ^D	3/4 – 1 1/2	40 000	70 000	12
55	5/8 – 1 1/2	55 000	85 000	12
60 ^D	5/8 – 1 1/2	60 000	90 000	9
75	5/8 – 1 1/2	75 000	100 000	8
100	5/8 – 1 1/2	100 000	125 000	6

^A Test of bars shall be performed full size.

^B Higher grades would be produced in 20 000-psi increments. The minimum tensile strength shall be 25 000 psi above the minimum yield strength. The minimum elongation shall be 4 % for all grades above 100.

^C Actual bar diameters are somewhat less than nominal, especially when roll threading methods are employed.

^D Grade 40 and 60 only apply to deformed bar.

TABLE 5 Load Support Requirements of Steel Bolts, Threaded Bars, Thread Deformed Bars (see Annex A2), and Threaded Slotted Bars Whose Slot Has Been Produced Without Metal Removal^A

Nominal Diameter (in.)/ Thread /in.	Thread Stress Area, in. ²	Grade									
		40 ^B		55		60 ^B		75		100	
		Yield lbs ^C	Ultimate lbs ^C	Yield lbs ^C	Ultimate lbs ^C	Yield lbs ^C	Ultimate lbs ^C	Yield lbs ^C	Ultimate lbs ^C	Yield lbs ^C	Ultimate lbs ^C
5/8 –11	0.226	<i>D</i>	<i>D</i>	12 400	19 200	13 600	20 300	17 000	22 600	22 600	26 300
3/4 –10	0.334	13 400	23 400	18 400	28 400	20 000	30 100	25 100	33 400	33 400	41 800
7/8 –9	0.462	18 500	32 300	25 400	39 300	27 700	41 600	34 700	46 200	46 200	57 800
1 –8	0.606	24 200	42 400	33 300	51 500	36 400	54 500	45 500	60 600	60 600	75 800
1 1/8 –7	0.763	30 500	53 400	42 000	64 900	45 800	68 700	57 200	76 300	76 300	95 400
1 1/4 –7	0.969	38 800	67 800	53 300	82 400	58 100	87 200	72 700	96 900	96 900	121 100
1 3/8 –6	1.155	46 200	80 900	63 500	96 200	69 300	104 000	86 600	115 500	115 500	144 400
1 1/2 –6	1.405	56 200	98 400	77 300	119 400	84 300	126 500	105 400	140 500	140 500	175 600

^A Tests of bolts and threaded bars shall be performed using full-diameter products.

^B Information for Gr 40 and 60 only applies to deformed bars.

^C Required yield and tensile loads shown are calculated by multiplying thread stress areas times the yield point and tensile strength values shown in Table 3. Thread stress area is calculated from the mean root and pitch diameters of adrenal threads as follows:

$$A_s = 0.7854 \left(D - \frac{0.9743}{n} \right)^2$$

where:

- A_s = stress area, in.²
- D = nominal diameter, in., and
- n = number of threads per inch.

^D 5/8 in. Gr 40 products are not covered.

or other methods involving metal removal are used, the mechanical properties of threaded slotted bolts shall be as specified in Table 6.

7.10 Threaded tapered plugs for expansion anchors must be capable of withstanding the minimum nonseizure load (MNSL) and minimum ultimate load (MUL), in accordance with Table 7.

7.11 Tension nuts must be capable of withstanding the ultimate tensile strength of the bolt or rebar of the highest grade with which they are to be used.

7.12 The mechanical properties of components of roof truss systems shall be in accordance with the appropriate paragraph(s) of this section.

TABLE 6 Load Support Requirements for Threaded Slotted Bars Whose Slot Has Been Produced by Methods Involving Metal Removal^A

Nominal Diameter, in.	Thread Stress Area, min, in. ²	Grade 55	
		Yield Load, min, lbf ^B	Ultimate Tensile Load, min, lbf ^B
1	0.606	30 000	46 400
1 1/4	0.969	48 000	74 200
1 3/8	1.155	57 200	88 400
1 1/2	1.405	69 600	107 500

^A Tests of bolts, threaded bars, and threaded slotted bars shall be performed using full-diameter products.

^B Required yield and tensile loads shown are calculated by multiplying thread stress areas times the yield point and tensile strength values shown in Table 2. Thread stress area is calculated from the mean of the mean root and pitch diameters of Class 3 external threads as follows:

$$A_s = 0.7854 \left(D - \frac{0.9743}{n} \right)^2$$

where:

- A_s = stress area, in.²
- D = nominal diameter, in., and
- n = number of threads per inch.

TABLE 7 Plug Grade Rating System

Nominal Diameter, in.	Grade 1		Grade 2		Grade 3		Grade 4	
	MNSL ^A	MUL ^B	MNSL ^A	MUL ^B	MNSL ^A	MUL ^B	MNSL ^A	MUL ^B
1/2	7.0	14.2	10.7	17.0	13.5	19.9	16.3	22.7
5/8	12.4	22.6	17.0	27.1	21.5	31.6	26.0	36.1
3/4	18.4	33.4	25.1	40.1	31.7	46.8†	38.4	53.4†
7/8	25.4†	46.2	34.7	55.4	40.0	64.7	40.0	73.9
1	33.3	60.6	40.0	72.7	40.0	84.8	40.0	96.9
1 1/8	40.0	76.3	40.0	91.6	40.0	106.8	40.0	122.0
1 1/4	40.0	96.9	40.0	116.3	40.0	135.7	40.0	155.0†
1 3/8	40.0	115.5†	40.0	138.6	40.0	161.7	40.0	184.8
1 1/2	40.0	140.5†	40.0	168.6	40.0	196.7	40.0	224.8

^A MNSL—Minimum Non-Seizure Load (1000 lb).

^B MUL—Minimum Ultimate Load (1000 lb).

7.12.1 Truss brackets shall be provided in 10 000-lbf grade increments.

7.13 Formable anchor materials shall conform to the applicable specifications of Section 5.

7.14 Mechanical properties for friction stabilizer shall conform to requirements specified in Specification A1011/A1011M, Table 4 HSLAS, Class 2 material. Specific mechanical properties for various size friction stabilizers are listed in Table 3 and Table 8.

7.15 Cable bolts, when pull tested to failure against the head assembly, must achieve 90% of the minimum breaking strength per Specification A416/A416M

7.16 Mechanical properties for expandable rock bolts shall meet manufacturer’s stated minimum yield, ultimate load, and elongation as per testing requirement defined in 10.16.

8. Dimensions, Mass, and Permissible Variations

8.1 Threaded bolts shall conform to the dimensions shown in Fig. 1.

TABLE 8 Load Support and Dimensional Requirements for Friction Stabilizers

Designation ^A	Nominal Diameter, in. ^B	Minimum Ultimate Load, lbs	OD tolerance, in.	Length Tolerance, in. ^C
33	1.33	20 000	± 0.03	+1/4, -1/2
39	1.54	23 000	+ 0.02,-0.04	+1/4, -1/2
46	1.81	32 500	± 0.03	+1/4, -1/2

^ADesignation denotes traditional reference to nominal millimeter diameter measurement as previously established.

^BAs measured across bolt diameter perpendicular to the slot as indicated in Fig. 7

^CBolt length is measured end-to-end (actual friction stabilizer tubing length).

8.1.1 Deformed bar bolts are bars that have been forged to produce one of the standard heads described in Fig. 1.

8.2 Threaded and threaded slotted bars shall conform to the dimensions shown in Fig. 2.

8.3 Thread Requirements:

NOTE 2—Thread size variations can be expected due to bar diameter and out-of-round variations. These special requirements reflect practices for external and internal threads that have been found to provide adequate strength and interchangeability.

8.3.1 External threads shall be in accordance with ASME B 1.1 UNC 1A except that the minimum pitch diameter has been reduced by 0.003 in. and the minimum major diameter has been reduced 0.010 in. to reflect the normal variations expected on hot-rolled bars due to the combined effect of bar diameter and out-of-round tolerances. Information on this increased tolerance is described in Note 3. The modified requirements are listed in Table 9.

NOTE 3—External threads that are to be used with threaded tapered plugs in expansion anchors are permitted to have somewhat increased pitch and major diameter tolerance. As bolt load is increased, the tendency for thread failure through nut diametrical expansion normally increases; however, in the case of threaded tapered plugs, increased load is accompanied by an increasing compression of the internal threads onto the external threads. This compensation for decreased major diameter is further augmented by the length of engagement which is longer than for standard nuts. Nuts to be used with threaded bars and threaded slotted bars shall be selected to provide adequate strength under these thread conditions.

8.3.2 External threads altered during the manufacturing process to facilitate product installation shall still maintain the 3 3/4 in. effective thread length. External threads at “head or exposed” end of bolt may have variable thread length for specific applications. Threads intended to be used to couple bolt sections together may be less than 3 3/4 in. effective thread length by agreement between supplier and purchaser for specific product applications.

8.3.3 Internal threads in threaded tapered plugs and threaded couplings shall be in accordance with ASME B 1.1 UNC 1B except that the threads shall be tapped oversize. This oversize is an increase in the pitch diameter of 0.003 in. to allow for handling damage on the external thread and dirt and long engagement in the internal thread. The maximum minor diameters are standard 1B for 1 1/2 to 3 diameter length of engagement. The modified requirements are listed in Table 9.

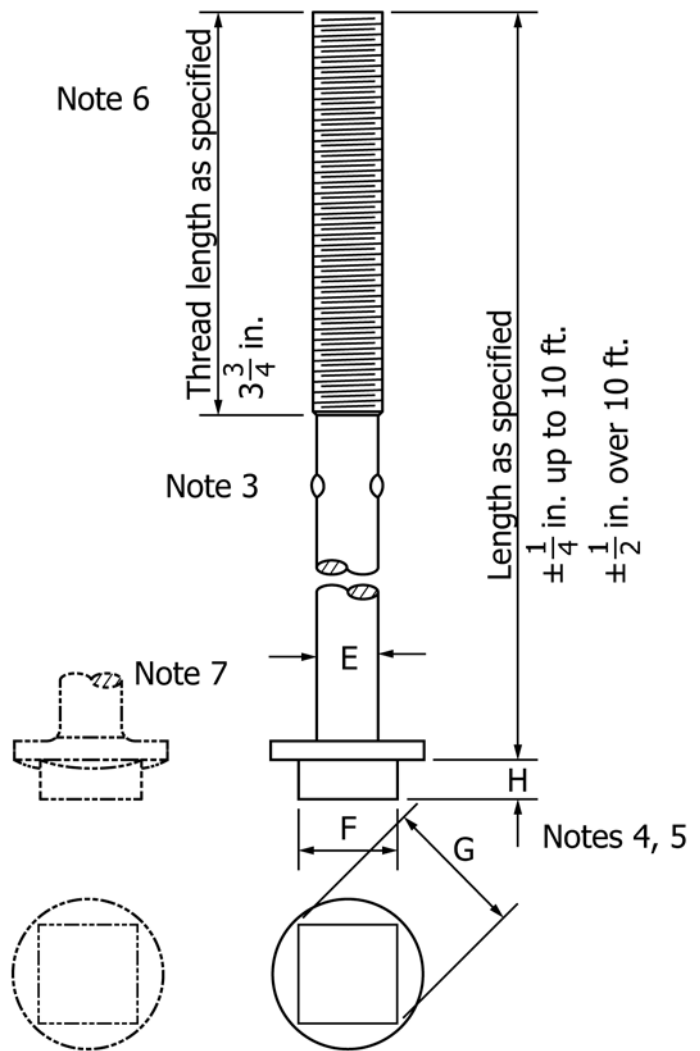

Nominal Bolt Size, 5/8 to 1 in. (Note 1)	
H Head Height, min., in.	0.476
F Head Across Flats, in.	1.088 to 1.125
G Head Across Corners, in.	1.425 to 1.591
E Body diameter is controlled by the roll threading operation.	

Note 1—When specified by the customer on the order or contract, the 5/8-in. diameter bolt may be supplied at:

- H—0.400
- F—0.906 to 0.938
- G—1.244 to 1.326

Note 2—When specified by the customer on the order or contract, a shoulder, collar, or swell equal to the body diameter of a 3/4-in. diameter bolt may be applied under the head of a 5/8-in. diameter bolt for a length of approximately 3/16 in.

Note 3—Pinched ears may be provided to support the expansion shell during installation.

Note 4—Bolt head may have depressed center.

Note 5—See Table 10 for head markings.

Note 6—See 8.3.1 for threads. Effective thread length shall be a minimum of 3/4-in. from any crimped location.

Note 7—Forging flash is permitted.

Note 8—External threads altered during the manufacturing process to facilitate product installation shall maintain the 3 3/4 in. effective thread length.

FIG. 1 Roof and Rock Bolts

8.3.4 Internal threads in nuts shall be tapped standard UNC 2B size in accordance with ASME B 1.1 or may be tapped oversize in accordance with 8.3.3 with agreement of producer and purchaser.

TABLE 9 Special Thread Requirements

External Threads		
Nominal Diameter, in.	Pitch Diameter, ^A in.	Major Diameter, ^B in.
5/8 –11	0.5531 to 0.5644	0.5952 to 0.6234
3/4 –10	0.6714 to 0.6832	0.7188 to 0.7482
7/8 –9	0.7884 to 0.8009	0.8423 to 0.8731
1 –8	0.9037 to 0.9168	0.9655 to 0.9980
1 1/8 –7	1.0161 to 1.0300	1.0882 to 1.1228
1 1/4 –7	1.1409 to 1.1550	1.2132 to 1.2478
1 3/8 –6	1.2493 to 1.2643	1.3353 to 1.3726
1 1/2 –6	1.3742 to 1.3893	1.4603 to 1.4976

Internal Threads		
Nominal Diameter, in.	Pitch Diameter, ^C in.	Maximum Minor Diameter, in.
5/8 –11	0.5690 to 0.5797	0.551
3/4 –10	0.6880 to 0.6995	0.668
7/8 –9	0.8058 to 0.8181	0.783
1 –8	0.9218 to 0.9350	0.896
1 1/8 –7	1.0352 to 1.0493	1.006
1 1/4 –7	1.1602 to 1.1746	1.131
1 3/8 –6	1.2697 to 1.2852	1.236
1 1/2 –6	1.3947 to 1.4105	1.361

^A Standard UNC 1A values except minimum reduced by 0.003 in.
^B Standard UNC 1A values except minimum reduced by 0.010 in.
^C Standard UNC 1B values increased by 0.003 in.

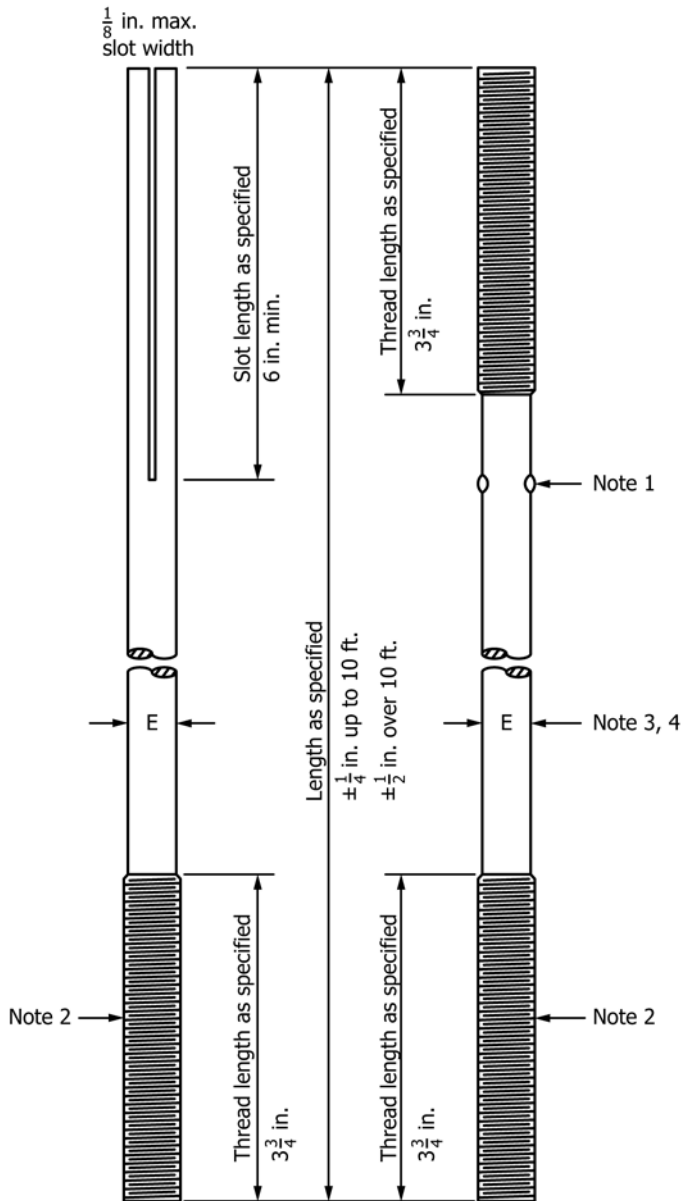

NOTE 1—Pinched ears may be provided to support the expansion shell during installation.
 NOTE 2—See 8.3.1 for threads. Effective thread length shall be minimum 3 3/4 in. from any crimped location.
 NOTE 3—E Body diameter is established by the method of threading.
 NOTE 4—Body diameter is controlled by the roll threading operation.
 NOTE 5—External threads altered during the manufacturing process to facilitate product installation shall maintain the 3 3/4 in. effective thread length.

FIG. 2 Threaded Bars and Slotted Threaded Bars

8.3.5 Gaging of threads shall be performed in accordance with System 21, ASME B 1.3M. Pitch diameter and thread crest diameter limits are specified in Table 9.

8.3.6 Threaded tapered plugs shall have a tapped length at least equal to one times the nominal bolt diameter with which they are to be used.

8.3.7 Threaded couplings shall have a tapped length at least equal to two times the nominal bolt diameter with which they are to be used.

8.4 Washer Requirements:

8.4.1 Round and square hardened washers shall be as shown in Fig. 3.

8.4.2 There are two types of hardened flat washers available. Type 1 is to be furnished unless otherwise specified.

8.4.2.1 Type 1 is either circular or square as shown in Fig. 3. It is designed for use with plate washers containing 1 3/8-in. holes, but may be used for all smaller hole sizes.

8.4.2.2 Type 2 is the hardened flat washer in accordance with Specification F436. It may be used only when sufficient clearance is available between the threaded-bar or threaded-rolled-bar body diameter near the head and the washer hole. This washer is not suitable for use with plate washers that contain holes that are more than 3/8 in. greater in diameter than the nominal bolt diameter.

8.5 Bearing and Header Plate Requirements:

8.5.1 Bearing and header plates may be of any thickness that successfully meets the test requirements in accordance with 10.4. The maximum hole size for use with bolts up to 3/4-in. nominal diameter shall be 1 3/8 in. except that hole size may be 1 1/2 in. when spherical washers or seats are used. Tolerance on hole diameter shall be -0, 1/8 in. Bearing plates for direct

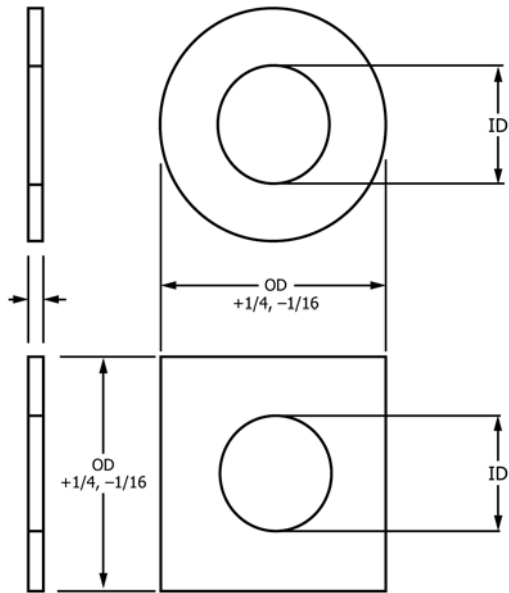

Bolt Size, in.	Nominal Outside Dimension, (O. D.) in.	Inside Diameter, (I. D.) in.	Thickness, in. (T)
5/8	2	1 1/16 to 27/32	0.122 to 0.177
3/4	2	1 3/16 to 31/32	0.122 to 0.177
7/8	2	1 5/16 to 1 5/32	0.132 to 0.177
1	2	1 1/8 to 1 9/32	0.132 to 0.177
1 1/8	2 1/2	1 1/4 to 1 13/32	0.132 to 0.177
1 1/4	2 1/2	1 3/8 to 1 17/32	0.132 to 0.177
1 1/2	3	1 5/8 to 1 25/32	0.132 to 0.177

FIG. 3 Round and Square Hardened Washer Type 1

bearing applications shall be 6 by 6 in. before the forming or shaping process with tolerances for length and width of $\pm 1/8$ in. Larger bearing plates may be furnished, dimensions and tolerances to be by agreement between the producer and the purchaser. Smaller bearing plates may be used in conjunction with steel channels, with other accessories, or in hard rock areas by agreement between the producer and the purchaser. Header plates are typically 6 in. wide by 16 to 18 in. long, or any other shape with an equivalent area.

8.5.2 Bearing and header plates used with frictional anchorage devices shall meet the test requirements in 10.4. The hole sizes and tolerances shall be set by the manufacturer of the frictional anchorage device.

8.6 General Components:

8.6.1 Dimensions not otherwise specified for cable head assemblies, tapered wedges, expansion shells, threaded tapered plugs, beveled washers, spherical washers, threaded couplings, and extensions shall be by agreement between the producer and the purchaser.

8.7 Nuts:

8.7.1 Nuts shall be hex, heavy hex, square, or heavy square in accordance with ASME B 18.2.2. Unless otherwise specified, the heavy series shall be supplied.

8.8 Surface Configuration on Formable Anchor Bars or Bolts:

8.8.1 Surface configurations on steel bars or bolts to be used with polyethylenes, as specified in 5.14.1.1, formable anchorage devices.

8.8.1.1 Three pitch modified reverse buttress form as described in Fig. 4.

8.9 Dimensions of Formable Anchor Tubes:

8.9.1 Dimensions of formable anchor tubes made from materials conforming to 5.14.1.

8.9.1.1 The wall thickness of the formable anchor tube shall be as specified by the manufacturer ± 0.015 in.

8.9.1.2 The weight per inch of formable anchor tubes shall be as specified by the manufacturer $\pm 8\%$.

8.9.1.3 The length of formable anchor tubes shall be as specified by the manufacturer ± 0.250 in.

NOTE 4—Barrier plugs may be used with the formable anchor tubes to separate grouted or chemically anchored segments of the bars or bolts from formable anchorage devices. In such cases, the barrier plug shall be considered as a portion of the tube length.

8.10 Dimensions of Expandable Rock Bolts:

8.10.1 Dimensions of expandable rock bolts shall be specified by the manufacturer. Nominal length dimensions shall be maintained between $+1/2$ in, -1 in. as agreed upon between manufacturer and purchaser.

8.10.2 Manufacturer shall specify original expandable rock bolt tubing diameter in the specific product certification documents.

9. Number of Tests and Retests

9.1 Bars—Two tension tests shall be made from each heat for each nominal diameter of bars unless the finished material from a heat is less than 30 tons, when one tension test will be sufficient. Certification by the bar supplier that the requirements of Table 4 have been met is an acceptable substitute for these bar tension tests.

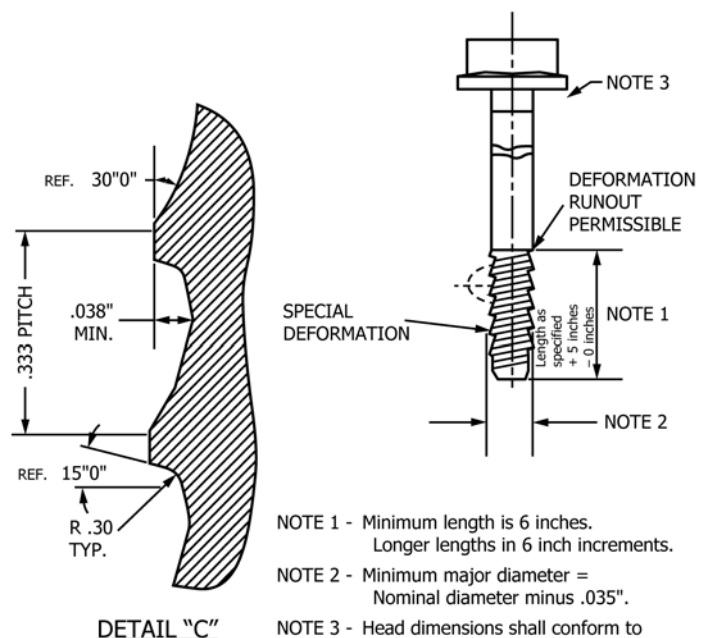

FIG. 4 Three-Pitch Modified Reverse Buttress Bolt

9.2 *Bolts, Threaded Bars, Threaded Slotted Bars, Bearing and Header Plates, Frictional Anchorage Devices, Expandable Rock Bolts, and All Types of Washers*—The requirements of this specification shall be met in continuous mass production. The manufacturer shall make sample inspections and tests to ensure that the product represented by the test samples conforms to the specified requirements. The manufacturer shall select and test a minimum of two bolts, threaded bars, threaded slotted bars, bearing and header plates, frictional anchorage devices, expandable rock bolts, and washers from each discontinuous turn or each 24 h of continuous production.

9.3 Improper machining or preparation of test specimens may give erroneous results. Improperly machined specimens shall be discarded and other specimens substituted.

9.4 If any test specimen fails to meet the specification requirements because of failure of testing equipment or improper specimen preparation, it may be discarded and another specimen taken.

10. Test Methods

10.1 Test bars used for the manufacture of bolts and threaded and threaded slotted bars for yield point, tensile strength, and elongation in accordance with the Determination of Tensile Properties Section of Test Methods and Definitions **A370**.

10.2 Tension test bolts and threaded bars in accordance with the Wedge Tension Testing of Full Size Product paragraph of Test Methods **F606** for tensile strength. Obtain the yield point in the course of this test by the Drop of the Beam or Halt of the Pointer Method as described in the paragraphs on Tension Testing of Machined Test Specimens of Test Methods **F606**.

10.2.1 If the length of the bolt or threaded bar exceeds the length that can be accommodated by the testing machine, then cut the head with a portion of the body in the case of bolts, and the thread with a portion of the body, from the bolt or threaded bar and test each separately.

10.2.1.1 Test the section containing the threads for yield point and breaking load by using the nut intended for use on the threaded portion and by gripping the bolt body. Failure may not occur by stripping of threads.

10.2.1.2 Test the section containing the bolt head with a 10° wedge under the head and by gripping the body. For smooth bars, it is permissible to increase the hole clearance in the wedge plate to two times the clearance specified in Test Methods **F606** to accommodate collars or swell under the bolt head. For deformed bars, it is permissible to increase the hole clearance of the wedge plate to four times the clearance specified in Test Methods **F606**.

10.2.1.3 Test bolts containing surface configurations by gripping a section of the surface configuration and the body of the bolt.

10.3 Threaded Slotted Bars:

10.3.1 Threaded slotted bars from which material has not been removed during the slotting operation (forged split-end bars) need not be tested on the slotted end.

10.3.2 Test threaded slotted bars from which material has been removed when making the slot at the slotted ends. If the

length of the bar exceeds the length that can be accommodated by the testing machine, then the excess length may be cut off and discarded.

10.3.2.1 Perform the test of the slotted end by first tack welding the two sides together at the extreme end of the bar. Grip both ends of this test bar and contain at least 1 in. of slot in the tested portion between the grips.

10.4 Tests of Bearing and Header Plates:

10.4.1 Locate the bearing plate sample centrally on a steel test plate containing a hole 4 in. in diameter. The steel test plate shall be the dimensions shown in **Fig. 5**. Exert a load on the bearing plate by either (1) assembling bolt, threaded rod and nut, or fixture through the bearing plate, placing the plate assembly on the crosshead of a testing machine and gripping the bolt, rod, or fixture and pulling down with the upper platen, or (2) pushing down with a punch having a diameter of approximately 1.75 in. or equal to the fixture's outside diameter, whichever is greater, mounted underneath the upper platen onto the plate assembly placed on the lower platen of the testing machine. If it is to be included in the actual installation, include in the test assembly a hardened washer of the type defined in this specification. Apply an initial preload of 6000 lbf and then place a measuring device accurate to 0.001 in. so as to be capable of measuring the axial movement of the bolt head or ram. Set the measuring device to zero after application of the 6000-lbf preload. Increase the load to 15 000 lbf and read the axial movement, defined as deflection, from the measuring device. The maximum permissible deflection between the 6000 and 15 000-lbf loads is 0.120 in. Continue the application of load until the grade rating of the plate is reached and again read the axial movement from the measuring device. The maximum permissible deflection between 6000 lbf and the grade rating is 0.250 in.

10.4.2 Test large bearing plates (maximum dimension greater than 7 in. and header plates for span performance in accordance with **10.4.2.1**).

10.4.2.1 Locate the plate sample centrally on a steel test plate containing a clear span of 6 in. The steel test plate shall be the dimensions shown in **Fig. 6**. Exert a load on the plate by either (1) assembling bolt, threaded rod and nut, or fixture through the plate, placing the plate assembly on the crosshead of a testing machine and gripping the bolt, rod, or fixture and pulling down with the upper platen, or (2) pushing down with a punch having a diameter of approximately 1.75 in. or equal to the fixture's outside diameter, whichever is greater, mounted underneath the upper platen of the testing machine. If it is to be included in the actual installation, include in the test assembly a hardened washer of the type defined in this specification. Apply an initial preload of 1000 lbf and then place a measuring device accurate to 0.001 in. so as to be capable of measuring the axial movement of the bolt head or ram. Set the measuring device to zero after application of the 1000-lbf preload. Increase the load to 5000 lbf and read the axial movement, defined as deflection, from the measuring device. The maximum permissible deflection between the 1000 and 5000-lbf loads is 0.250 in.

The test described in **10.4.2.1** shall be performed to establish product performance whenever manufacturing process,

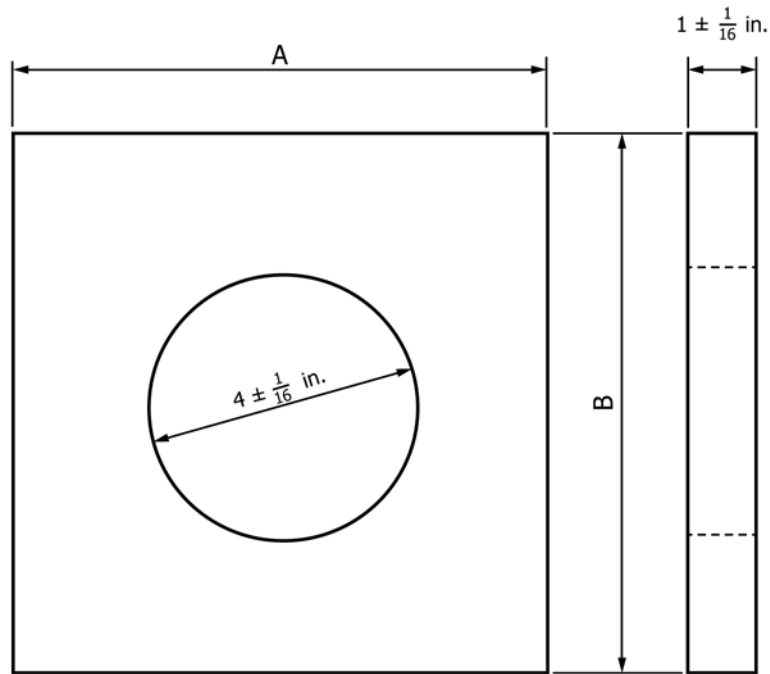

- NOTE 1—A 36 or similar steel.
 NOTE 2—Hole to be centrally located.
 NOTE 3—Dimensions A and B shall each be a minimum of 2 in. longer than the comparable dimensions of the bearing or header plates to be tested.

FIG. 5 Bearing Plate Test Plate

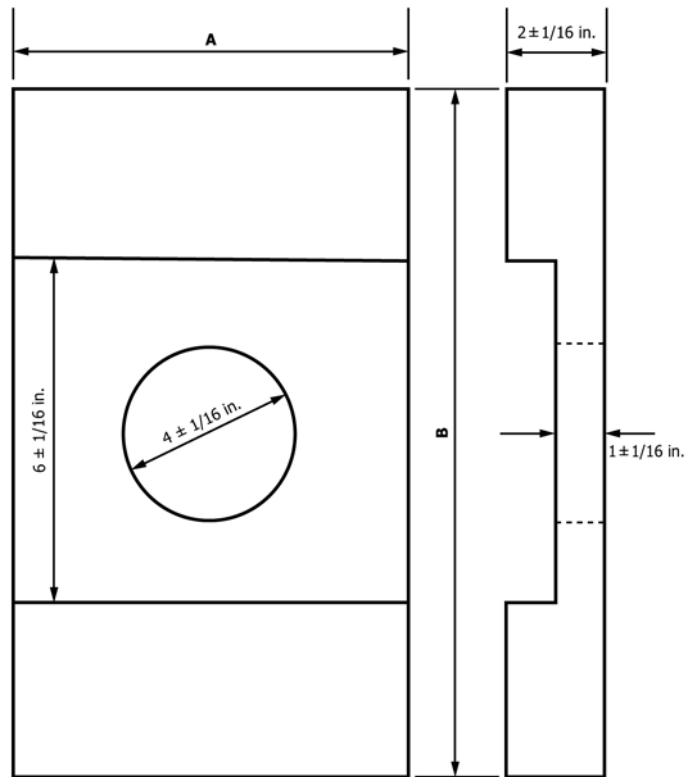

- NOTE 1—A36 or similar steel.
 NOTE 2—Slot to be centrally located.
 NOTE 3—Dimensions A and B shall each be a minimum of 2 in. longer than the comparable dimensions of the bearing or header plates to be tested.

FIG. 6 Span Test Plate

material, or product design changes occur. Bearing plates made from hot-rolled sheet materials covered in this section shall not be required to be routinely tested per 9.2 requirements. Large bearing plates made from other than hot-rolled sheet materials shall still be required to meet 9.2 and 10.4.2.1 requirements.

NOTE 5—The inclusion of components such as spherical nuts, spherical washers, wooden header boards, metal channels, etc., in the rock bolt assembly can significantly affect bearing plate performance. While these items are not to be included in the standard grade rating and span tests described in 10.4.1 and 10.4.2.1, their influence should be reviewed on an individual basis where bearing plate strength has become an issue.

10.5 Perform hardness tests of washers and bearing and header plates in accordance with Test Methods F606.

10.6 Tests of wedges for use with slotted bolts are not ordinarily contemplated.

10.7 Expansion shells and threaded tapered plugs shall be tested by the manufacturer in accordance with the specification to which they are supplied.

10.8 This test is to determine the grade rating specified in Table 7 for threaded tapered plugs used in expansion anchors. This test is not considered to be a routine test to be performed during manufacture, but must be applied in cases where the strength and performance of the threaded tapered plug have become an issue. This test can be executed in a variety of ways, all of which must include installation of the bolt, expansion shell, and threaded tapered plug in a straight section smooth hole of a diameter recommended by the manufacturer ± 0.030 in. The test cylinder or block shall be fabricated to dimensions that will allow the expansion anchor to be completely inserted into the hole and prevent lateral distortion of the hole during testing. The test shall be performed by tightening the assembly in the hole and then loading to the minimum nonseizure (MNSL) load for the grade of plug specified in Table 7. This loading after the initial setting shall be either by axial loading or by the turning of the bolt. The assembly shall then be removed from the test cylinder or block and examined. Following an initial full turn (with a wrench, if necessary), the plug must be removable by a torque load not to exceed 10 ft-lb. The threaded tapered plug shall not have ruptured nor the threads stripped. Threaded tapered plugs for expansion shells must also be capable of withstanding the minimum ultimate load (MUL) for the grade of plug specified in Table 7. This test shall be conducted by repeating the previous procedure and loading the assembly to the MUL. The assembly then shall be removed and examined. No stripping of the plug threads shall have occurred. At the MUL, distortion of the plug or bolt threads, or both, may preclude the removal of the plug.

NOTE 6—When threaded tapered plugs for expansion shells are used in conjunction with chemical grouting materials, the provisions of 7.10 also are applicable.

10.9 See Annex A1 for information concerning performance tests of expansion shell, tapered plugs, tapered wedges, and other anchorage methods and materials.

10.10 Nuts shall be manufactured and tested in accordance with the specification to which they are supplied, except that when so specified on the order or contract nuts of tapped sizes

$\frac{5}{8}$ and $\frac{3}{4}$ in. may be the same $1\frac{1}{8}$ -in. dimension across flats as the head of the bolt shown in Fig. 1.

10.11 Tension nuts must be capable of withstanding the ultimate tensile load capacity of the bolt or rebar of the highest grade with which they are to be used. This test is not considered to be a routine test to be performed during manufacturing, but must be applied in cases where the strength and performance of the threaded tension nuts have become an issue. This test may be carried out by engaging the threaded tension nut with the bolt or rebar, supporting the tension nut and then loading to the ultimate tensile strength (to destruction) of the highest grade bolt or rebar to be used. The assembly shall then be removed and examined. The threaded tension nuts shall not have ruptured nor the threads be stripped. At ultimate tensile loads, distortion of the bolt threads as well as elongation of the bolt in the engaged thread zone may preclude the removal of the tension nut.

NOTE 7—Residual torques are permissible due to the various stop mechanisms used in tension nut designs. These stop mechanisms must not distort the threaded engagement area between the bolt/rebar and tension nut. Residual torque shall be determined by the manufacturer.

10.12 Tests of Notched Bendable Bolts:

10.12.1 Notched bendable bolts shall be capable of being bent through one bending cycle as follows: the bend shall be in the area of the reduced cross section, to an angle of 90° , with respect to its original position. The bar at the reduced section shall neither be guided nor restrained during the test. The bolt shall then be bent in the same manner back to its original position. At the conclusion of the bend test, any obvious visible evidence of cracking shall constitute reason for rejection.

NOTE 8—It is recommended that during the initial tool up process, prototype samples be subjected to multiple bending cycles to ensure adequate notch design.

10.12.2 Bolts successfully passing the bend test shall be tension tested with the bendable section in the zone of the tension test. Fully grouted nontensioned bendable bolts shall have reached a load of 23 000 lbf before breaking. Tensioned bendable bolts shall exceed the minimum yield loads in accordance with Specification A615/A615M or this specification, or both, for the grade and diameter of bolt used, plus 6000 lbf. There should be no evidence in the fracture of a prior fracture as a result of the bending test.

10.13 Tests of Roof Truss Components:

10.13.1 All components of roof truss systems shall be tested in accordance with the appropriate paragraph of Section 10 of this specification.

10.13.2 Truss brackets shall be tested to failure on a steel fixture in a position consistent with their intended use. Active loads shall be applied to the truss bracket through (1) the angle bolt while the horizontal member is held stationary, and through (2) the horizontal member while the angle bolt is held stationary. The bracket rating shall correspond to the lowest failure load determined by the tests described here.

10.13.2.1 Truss brackets used as primary support shall be tested as intended to be used over a 4-in. round hole at an appropriate angle to ensure that the bracket meets the minimum strength requirements of 10.4.

10.14 Tests of Friction Stabilizers :

10.14.1 The friction stabilizer device, with no modifications or alterations for testing, is installed through a test plate with the end of the friction stabilizer (commonly referred to as the head, collar, bearing, or welded-ring end) against the test plate. A stud or plug may be inserted in the opposite end of the friction stabilizer section as necessary to grip the friction stabilizer in the test machine apparatus (see Fig. 8). The intent of the test is to examine the integrity of the bearing or head end of the friction stabilizer in a method similar to the product's end use application. The test plate must be of sufficient thickness to reach the minimum ultimate bolt load without test plate failure. The test plate hole minimum diameter must be the nominal friction stabilizer diameter plus 0.030 in. minimum for clearance (for example, for the designated 39 type friction stabilizer, the test plate hole diameter should be 1.54 in. + 0.060 in = 1.600 in.). The test plate hole should be of sufficient diameter to load the bolt above the minimum ultimate load to test the integrity of the head end of the friction stabilizer. The various sizes of friction stabilizers shall be loaded to the MUL listed in Table 8 with no destruction of the head end as determined by visual inspection.

10.15 Test of Cable Bolts:

10.15.1 The cable bolt sample is generally prepared with head assemblies on both ends as illustrated in Fig. 9. One of the test cable head assemblies shall be the type that will be on the final manufactured product. The other end of the test cable may be gripped by any head assembly style or by gripping the cable strand.

10.16 Test of Expandable Rock Bolts:

10.16.1 Expandable Rock Bolt finished product tests:

10.16.1.1 Expansion test—The finished product shall be fully expanded unconfined at manufacturer's recommended installation pressure.

10.16.1.2 Ferrule test: Bolt shall be tensile tested to determine that the ferrule-to-bolt weld tensile strength meets or exceeds profile breaking load specification. The general test setup shall be as shown in Fig. 10 and Fig. 11. The specific test

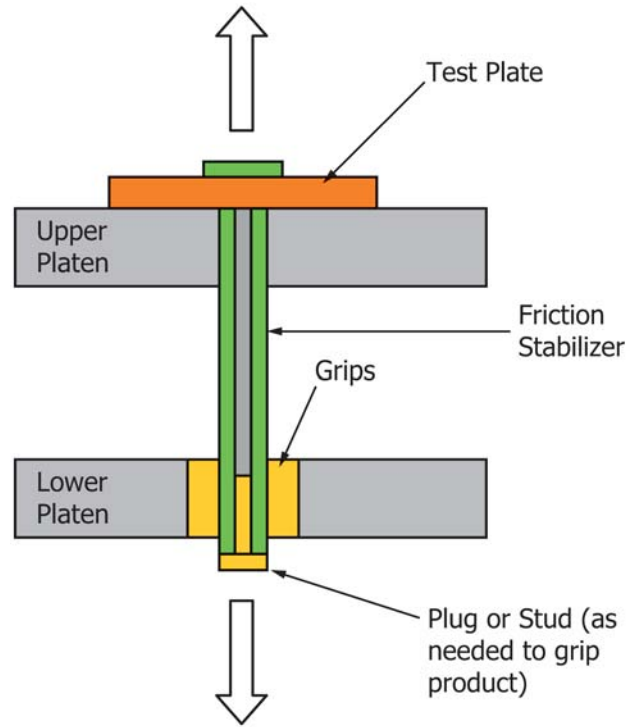

FIG. 8 Friction Stabilizer Generalized Test Apparatus

method shall be specified in the manufacturer documentation supplied to the customer.

10.16.2 Expandable Rock Bolt Mechanical Property Tests:

10.16.2.1 Ultimate Tensile Load shall be determined on the bolt section after expansion, within manufacturer's expansion dimension range, per specifications in Test Methods A370. The sample used for ultimate load testing can be obtained from the full size expansion test product from 10.16.1.

10.16.2.2 To determine Yield and Ultimate Tensile Load, and Elongation, the bolt section after expansion, within manufacturer's expansion dimension range, shall be tested per specifications in Test Methods A370

10.16.2.3 Manufacturer shall specify the referenced Test Methods A370 section to describe the mechanical property test procedure. Document the test procedure and the specimen size.

11. Quality Assurance and Inspection

11.1 If the inspection described in 11.2 is required by the purchaser, it shall be specified in the inquiry and in the contract or order.

11.2 Manufacturers of roof and rock bolts and accessories shall be responsible for establishing and maintaining a quality assurance program to ensure that all materials conform to the appropriate requirements of this specification. The manufacturer shall afford the purchaser's inspector all reasonable facilities necessary to satisfy him that the material is being produced and furnished in accordance with this specification. Mill inspection by the purchaser shall not interfere unnecessarily with the manufacturer's operations. All tests and inspection shall be made at the place of manufacture, unless agreed otherwise.

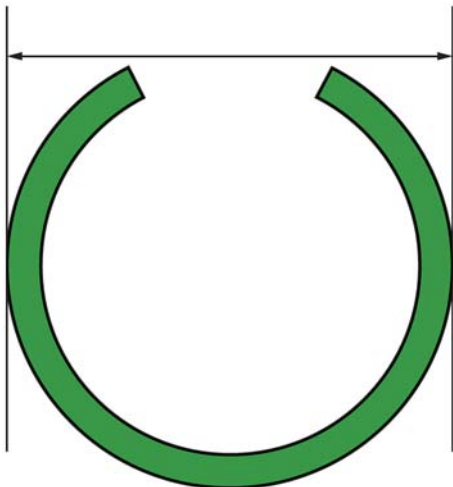
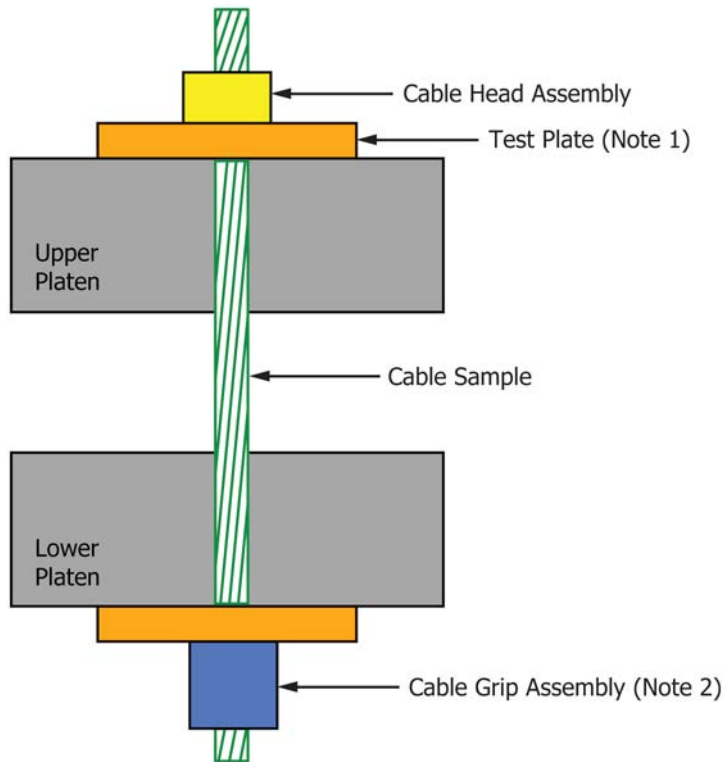

FIG. 7 Friction Stabilizer Diameter Measurement



NOTE 1—Test Plate can be designed to mate with the contacting surface of the Cable Head Assembly

NOTE 2—Only one end of the cable shall be required to have a Cable Head Assembly. The other end of the test cable can have other Cable Grip Assembly

FIG. 9 Generalized Cable Bolt Test Apparatus

12. Rejection and Rehearing

12.1 Material that fails to conform to the requirements of this specification shall be rejected. Rejection shall be reported to the producer or supplier promptly and in writing. In case of dissatisfaction with the results of the test, the producer or supplier may make claim for a rehearing.

13. Certification

13.1 Upon request of the purchaser in the contract or order, a manufacturer's certification shall be furnished that the material was manufactured and tested in accordance with this specification.

14. Responsibility

14.1 The party responsible for the fastener shall be the organization that supplies the fastener to the purchaser.

15. Product Marking

15.1 Bolt heads shall be marked as shown in Table 10 with either raised or depressed marks at the option of the manufacturer. Marks shall include grade and diameter identification when applicable, manufacturer's symbol, and the bolt length in either inches or feet as specified in the order or contract.

15.2 Friction stabilizers shall be marked with either raised or depressed marks at the option of the manufacturer. The location of the marks shall be such as to be readable after installation. Marks shall include model identification when

applicable, manufacturer's symbol, and the length in either inches or feet as specified in the order or contract.

15.3 Threaded bars and threaded slotted bars shall be color coded as shown in Table 11 to indicate bar length. The color shall be applied such that it will be visible after installation of the roof support device.

15.4 Beveled washers, threaded tapered plugs, wedges, spherical washers, and threaded couplings are not required to be marked.

15.4.1 Threaded tapered plugs produced in only one grade, as specified in Table 7, require no special identification if the plugs are uniquely identified by thread diameter and plug design. A plug having the same thread size and manufactured to more than one grade rating shall be identified by color coding or physical marking as specified by the manufacturer.

15.5 Deformed bearing and header plates shall be marked on the exposed face with the manufacturer's symbol.

15.6 Bearing and Header Plates:

15.6.1 Bearing and header plates manufactured to the minimum grade rating in accordance with 7.4.1 do not require markings to indicate grade rating.

15.6.2 Bearing and header plates manufactured to a grade rating higher than 20 000 lbf shall be marked with a single number that indicates the rating divided by 10 000 lbf. For example, the number 3 would designate a 30 000-lbf grade rating.

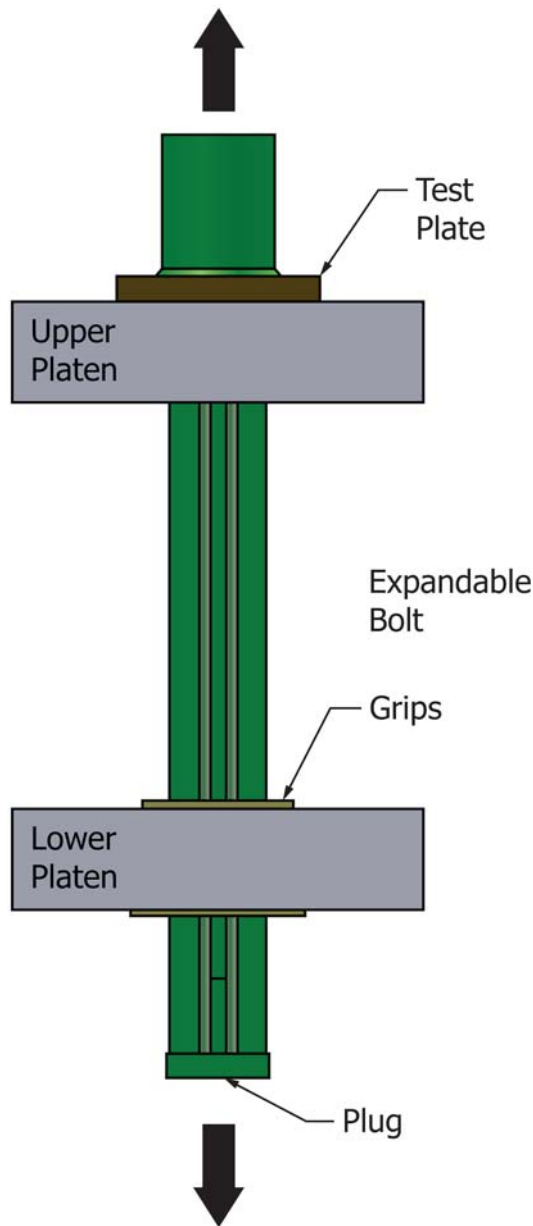

FIG. 10

15.7 Nuts shall be marked in accordance with the specification to which they were manufactured.

15.8 Expansion shells shall be marked with the manufacturer's symbol and the hole size for which they are intended.

15.9 Each hardened washer shall be marked with a symbol identifying the manufacturer. Random washers may contain multiple markings. Markings shall be depressed on one face of the washer.

15.9.1 Other identifying or distinguishing marks, or both, may be used by the manufacturer.

15.10 Extensions are not required to be marked.

15.11 Truss brackets shall be marked as shown in Table 10. Markings shall include the manufacturer's symbol and the grade rating as determined by the test in accordance with

10.13.2. The grade identification shall consist of a single number that indicates the grade rating divided by 10 000 lbf . For example, the number 3 would designate a 30 000-lbf grade rating.

15.12 Formable anchor tube container will be marked with nominal formable anchor tube length, bar or bolt diameter, wall thickness, weight per inch, and hole diameter with which tube is to be used.

15.12.1 Color coding of formable anchor tubes for mines using more than one bar or bolt diameter shall be established by the manufacturer.

15.13 Cable bolts shall be identified by manufacturer, cable type and diameter, and bolt length. Cable bolts shall be color coded as shown in Table 12 or marked to indicate length. The

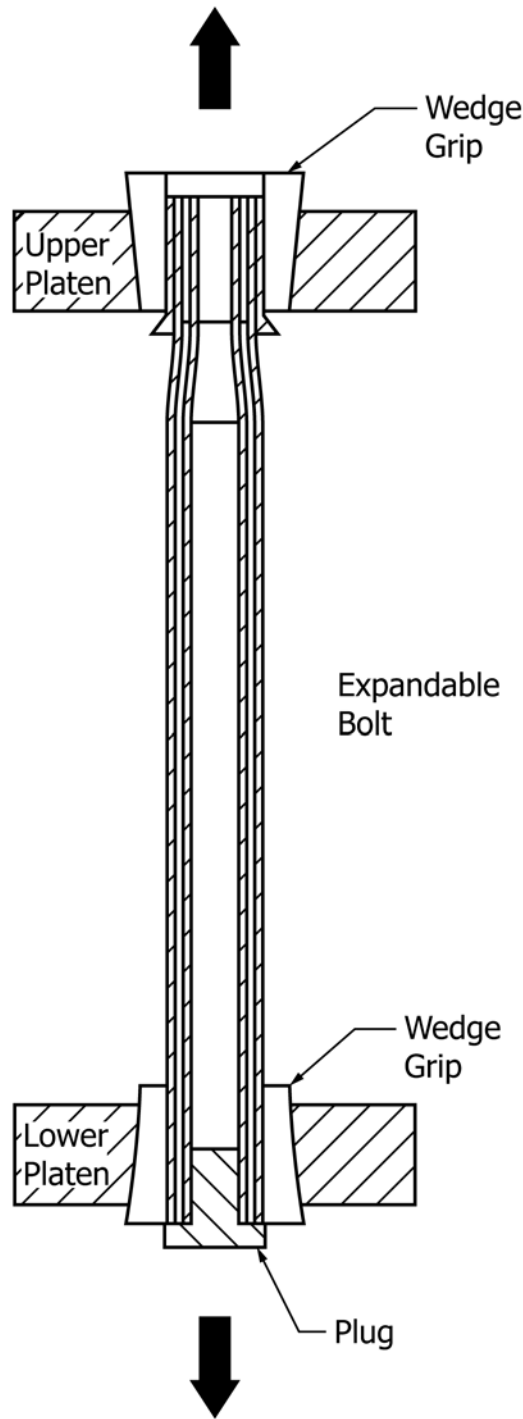

FIG. 11

color or marking, or both shall be applied to be visible after installation of the roof support device.

15.13.1 Cable sections installed without wedge grip assemblies shall be identifiable for length during the installation process. This pertains to cable sections installed and anchored in drill holes.

NOTE 9—"After" installation is intended to refer to a "reasonable" amount of time after installation. It is recognized the mine conditions can

cause product identification problems due to wet and corrosive environments. Forging and tooling stamps, and color identifications, can become illegible in a short time period. The manufacturer shall supply product that is readily identifiable "during" and "through" the installation process subject to reasonable product storage conditions.

15.14 *Expandable Rock Bolts:*

TABLE 10 Markings^{A,B,G}

	Nominal Product Size	Manufacturer's Symbol ^C	Diameter ^D	Grade ^E	Length in Inches (or Millimetres)
Headed Plain Bolts					
GR 40 ^F	3/4 –diameter and over	yes	yes	none	yes
GR 55	5/8 –diameter and over	yes	yes	★	yes
GR 60 ^F	5/8 –diameter and over	yes	yes	△	yes
GR 75	5/8 –diameter and over	yes	yes	×	yes
GR 100	5/8 –diameter	yes	yes	□	yes

^ANo marks are required on the beveled washers, threaded couplings, or extensions.

^BNo other markings may be used to designate additional specifications and will be defined in the manufacturer's literature.

^CEnter alpha numerical symbol

^DEnter numerical value of bolt or bar diameter measured in eighths, for example, 5. Numerical value of non-full-dimension bar to have numerical value and specific manufacturer designation.

Numerical value of full dimension deformed bars to be placed in a circle, for example ⑤

^EGrades greater than 100 psi are to be produced in 20 000–psi increments and marked as follows:

▣ for 120 psi,

▣ for 140, etc.

^FGrade 40 and 60 only apply to deformed bar.

^GMarking editions noted in Note D of F432-10 shall be implemented as manufacturing tooling changes occur by agreement between the Mine Safety and Health Administration (MSHA) and manufacturers.

TABLE 11 Color Codes for Threaded Bar and Threaded Slotted Bars

Length, in. (ft.)	Color
30	Purple
36	Yellow
42	Green
48	No Color
60	Red
72	Blue
84	Orange
96	White

15.14.1 Expandable rock bolts shall be marked to identify manufacturer, length, and bolt type designation. The identification markings shall be readable after product installation.

15.14.2 For length determined by color codes, the color designation shall correspond with the designations in **Table 12**. Specific identification may be determined by agreement between manufacturer and purchaser.

TABLE 12 Cable Bolt and Expandable Rock Bolt Color Codes

Length, ft	Color
5	Red
6	Dark Blue
7	Orange
8	White
9	Fluorescent Green
>=10, <12	Safety Yellow
>=12, <14	Dark Green
>=14, <16	Brown
>=16, <18	Unpainted
>=18, <20	Light Blue
>=20, <22	Black
>=22, <24	Pink
>=24, <26	Purple

Note: For odd length cables over 10 ft., the color will be the next lowest color identifier.

16. Keywords

16.1 bolts, roof and rock and accessories; rock bolts; roof bolts

ANNEXES

(Mandatory Information)

A1. ON-SITE TESTING TO DETERMINE EFFECTIVENESS OF ROOF SUPPORT DEVICES

A1.1 The suitability of roof and rock bolts and accessories for specific applications in underground mines depends upon the particular ground and rock conditions at the site of intended use. For this reason, it may be necessary to perform appropriate tests at the actual site of intended use to evaluate the effectiveness of the roof support devices.

A1.2 By agreement, the supplier and the purchaser will determine the appropriate tests to evaluate the merits of any specific roof support device on site.

A2. THREAD DEFORMED BARS

A2.1 Thread deformed bars are steel bars that have a continuous hot-rolled pattern of threadlike deformations along their entire length that allow nuts and couplers to thread onto the bar at any point.

A2.2 Thread deformed bars shall be manufactured in compliance with the chemical and mechanical property requirements of Specification **A615/A615M**.

A2.3 Thread deformed bars, nuts, and couplers shall be identifiable in regard to their manufacturer, chemical and mechanical properties.

NOTE A2.1—Due to the manufacturing process, markings to designate size, minimum yield, and type of steel are not required.

A2.4 The effective stress area of thread deformed bars shall be equal to the nominal area of the bar.

A2.5 The dimensions of the threadlike deformations along the bar shall be adequate to develop, when engaged with a tension nut or coupler of the designated size, the ultimate strength of the thread deformed bar.

A2.6 Tension nuts for use with thread deformed bars shall have internal threads of sufficient strength to develop the

ultimate tensile strength of the bar with which they are used. These nuts shall be marked with the letter T.

A2.7 Yieldable nuts for use with thread deformed bars shall be designed to yield in incremental displacements along the bars at predetermined bolt loads to allow for rock deformations under controlled support conditions.

A2.7.1 Standard yieldable anchor nuts shall develop at least 125 % of the specified minimum yield strength of the bars with which they are used. No strength identification marking is required.

A2.7.2 Yieldable slip nuts designed to slip at loads less than 125 % of the specified minimum yield are permitted. This percentage shall be marked on the nut.

A2.8 Couplings used with thread deformed bars shall conform to **7.6**.

A2.9 Test methods and markings for thread deformed bars shall be consistent with the intended use of the bars in accordance with the appropriate sections of this specification.

A3. CHEMICAL GROUTING MATERIALS

A3.1 Strength Index for Chemical Grouting Materials

A3.1.1 This is a laboratory test for measuring the strength index of 6-in. long chemical anchors. The strength index is a numerical designation ranging from 1 to 10 that represents the load in tons that can be supported by a chemical anchor with less than 0.100 in. of bar movement when tested as outlined in this section. It is not intended to reflect actual in-mine performance or replace appropriate mine tests in accordance with A1.1.

A3.1.2 Prepare the test section as shown in Fig. A3.1. Item No. 1 is a No. 6 thread-deformed, reinforcing bar as described in Annex A2. Item No. 2 is a 1-in. inside diameter (I.D.) by 1½-in. outside diameter (O.D.) steel tube with 27 by 3 internal metric thread. Item No. 3 is a fully grouted, void-free, cured chemical anchor.

NOTE A3.1—It is required that the test section be cut from a large sample using a threaded tube length of at least 9 in. and a grout cartridge clipped at both ends, where cartridge is use is applicable. The length of thread-deformed bar used must be sufficient to allow attachment of the loading apparatus (see Fig. A3.1) to the protruding end. Care should be taken to ensure that the test section is completely grouted and void free throughout.

A3.1.3 Preparation of Test Section Degrease tube and bar. Stabilize all components at a single temperature between 50 and 80°F. The specimen shall be prepared by placing the grout cartridge or chemical grout mixture into the threaded tube, inserting the bar and rotating the bar clockwise in accordance with the chemical grout manufacturer’s installation instructions. The specimen shall be cured for 24 h before cutting the test section.

A3.1.4 Test Apparatus Hydraulic ram with hollow center large enough to accept bar, manual hydraulic pump with a connecting hose and gage, and a dial indicator that measures movement to one thousandth of an inch.

A3.1.5 Test Procedure As shown in Fig. A3.1, assemble the test section into the fixture and hydraulic ram. Attach the dial indicator to the steel tube to indicate movement of the cut end of the bar with respect to the tube.

A3.1.6 Manually apply load to the test section with the hydraulic ram in increments of 1 to 10-tons maximum load.

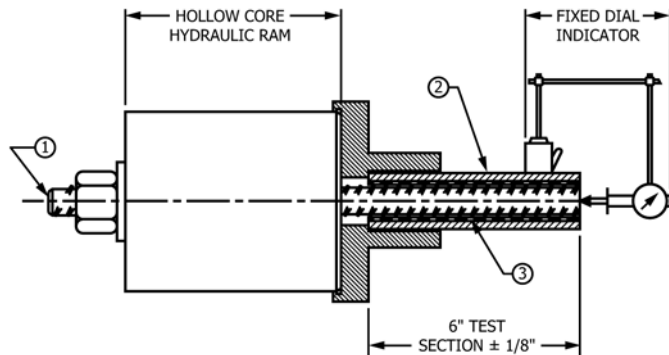

FIG. A3.1 Chemical Grouting Strength Index Test Apparatus

Each increment of load shall be stabilized for a period of 1 min prior to reading the dial indicator. If movement exceeds 0.100 in., terminate the test.

NOTE A3.2—Do not exceed 10 tons due to bolt stretch and safety considerations.

A3.1.7 Number of Tests—A minimum of five tests are required. Eighty percent must achieve the strength index.

A3.2 Speed Index

A3.2.1 This is a laboratory test to determine the speed index of chemical grouting materials. The speed index indicates the time in seconds from completion of mixing until an anchorage level of 4000 lb is achieved when tested in accordance with this section. Grout formulations shall be identified in accordance with the speed index classification system of Table A3.1.

NOTE A3.3—Mine and installation conditions such as temperatures, annulus size, bolt length, and rotational speeds will effect results.

A3.2.1.1 Test apparatus is illustrated in Fig. A3.2. Degrease steel tube and bar before using. Stabilize all components at 55 to 60°F. Thread steel tube onto the base plate stud and position the steel support collar over the steel tube. Place the hollow core hydraulic ram on top of the steel support collar. Thread the No. 6 hex nut and the headed blind nut onto the thread deformed reinforcing bar so that the two nuts are locked.

NOTE A3.4—The thread deformed reinforcing bar must be long enough to ensure a 12-in. (+½, -0) grouted length.

A3.2.1.2 Place a sample of grout of sufficient volume to encapsulate a 12-in. (+½, -0) long section of No. 6 thread deformed reinforcing bar into the steel tube. Insert the bar (with nuts attached) through the grout in 5 s or less (rotating through the grout is optional). As necessary for grout mixing, immediately spin the bar clockwise at a speed between 400 and 500 r/min to mix the grout for the time recommended by the manufacturer. Begin timing for speed index determination at the conclusion of mixing and allow the grout to cure for the period of time in seconds listed in Table A3.1 corresponding to the speed index assigned by the manufacturer. Once the cure time has elapsed, immediately load the bar with the ram. A load level of 4000 lb must be achieved within 3 s of the start of loading.

A3.3 Cartridge Equivalent Length Requirements

A3.3.1 Cartridges of chemical grouting materials shall contain sufficient volume to fill the annulus between the bolt and

TABLE A3.1 Speed Index Classification

Speed Index	Maximum ^A Cure Time, s
15	15
30	30
60	60
240	240
600	600
1000	>600

^A To achieve 4000-lb test load (see A3.2.1.1).

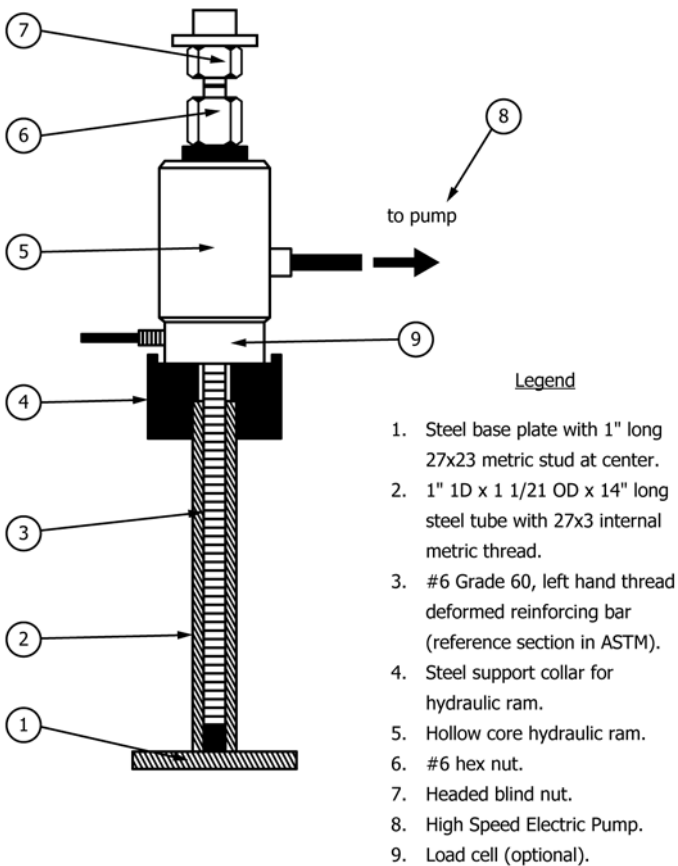

FIG. A3.2 Speed Index Test Apparatus

- Legend**
1. Steel base plate with 1" long 27x23 metric stud at center.
 2. 1" 1D x 1 1/21 OD x 14" long steel tube with 27x3 internal metric thread.
 3. #6 Grade 60, left hand thread deformed reinforcing bar (reference section in ASTM).
 4. Steel support collar for hydraulic ram.
 5. Hollow core hydraulic ram.
 6. #6 hex nut.
 7. Headed blind nut.
 8. High Speed Electric Pump.
 9. Load cell (optional).

$$V_g = V_h - V_b$$

where

- V_g = required grout volume, in.³,
 V_h = borehole volume, in.³, and
 V_b = bolt volume, in.³.

The borehole volume shall be calculated by using the following:

$$\text{Borehole Diameter} = \text{Nominal Diameter} + 0.043 \text{ in.}$$

$$\text{Borehole Length} = \text{Bolt Length} + 1 \text{ in.}$$

The bolt volume shall be based on nominal reinforcing bar cross sections in accordance with Specification A615/A615M.

NOTE A3.5—When bolts with cross-sectional areas different from those specified in Specification A615/A615M are used, adjustments to the calculated equivalent length may be necessary.

A3.4 Product Marking

A3.4.1 Cartridges of chemical grouting materials are not required to be marked. Containers of chemical grouting cartridges and chemical mixtures shall be labeled to provide the following information:

A3.4.1.1 Container labels shall provide general product information including manufacturer, formulation designation, and number of cartridges, as applicable, in the container as shipped.

A3.4.1.2 Container labels shall provide nominal system data including recommended hole diameter, bolt diameter, and cartridge equivalent footage (see A3.3). Labels may list more than one hole/bolt/eq.ft. combination if multiple product applications are possible.

A3.4.1.3 Container labels shall provide standard data including cartridge length and diameter, as applicable, speed index (see A3.2) and “use by (date).”

A3.4.1.4 Nominal installation data including recommended mix time (seconds) and mixing speed (r/min) shall be included on, or within, the container.

A3.4.1.5 Strength index shall be placed on the container label, within the container, or in the manufacturers’ literature.

borehole wall as specified in A3.3.2. The volume will be identified by an equivalent length designation (ft) indicating the length of borehole grouted by the cartridge for the nominal bolt/borehole combination used.

A3.3.2 Minimum cartridge volumes required for specified equivalent length designations shall be calculated by using the following equation where the equivalent length (EL) is equal to the bolt length:

A4. SELF DRILLING RESIN CONTAINING BOLTS

A4.1 “Self Drilling Resin Containing” (SDRC) bolts are self-drilling hollow bolts with threads, deformations, or other design features to provide interlocking between the bolt material and the chemical grout. SDRC bolts have an integrated resin cartridge. SDRC bolt resin volume requirements are calculated based on full encapsulation during installation.

A4.2 SDRC bolts shall be identifiable in installed state regarding to the following information: (1) Manufacturer, (2) Ultimate Tensile Strength, (3) Bolt Length, and (4) Bolt Diameter.

A4.2.1 SDRC bolts shall be identifiable regarding the resin manufacturing date, resin manufacturer, and resin designation.

A4.3 Nuts, tension nuts and couplers for use with the SDRC bolts shall have internal threads of sufficient strength to develop the ultimate tensile strength of the bolt.

A4.4 Bolt samples shall meet the requirements of Section 9 and be tested in accordance to test procedures 10.1 and 10.2.

A4.5 Chemical grout strength index shall be determined with an SDRC bolt specimen following test procedure A3.1.

A4.6 Chemical grout speed index shall be determined with an SDRC bolt specimen following test procedure A3.2.

A4.7 Cartridge Equivalent Length will be calculated as required by A3.3

A5. SELF DRILLING BOLTS

A5.1 “Self Drilling” (SD) bolts are self-drilling bolts with threads, deformations, or other design features to provide load transfer between the bolt and the chemical or mechanical anchor and to the borehole surface.

A5.2 SD bolts shall be identifiable during the installation process and, where practical, in installed state regarding to the following information: (1) Manufacturer, (2) Ultimate Tensile Strength, (3) Bolt Length, and (4) Bolt Diameter.

NOTE A5.1—Some self drilling bolts intended for “spiling” type

applications are not required to have readily identifiable components after installation. Identification shall be by agreement between manufacturer and customer.

A5.3 Nuts, tension nuts and couplers for use with the SD bolts shall have internal threads of sufficient strength to develop the ultimate tensile strength of the bolt.

A5.4 Bolt samples shall meet the requirements of Section 9 and be tested in accordance to test procedures 10.1 and 10.2.

A6. SURFACE CONTROL PRODUCTS

A6.1 Surface Control products, typically used in conjunction with ASTM approved bolts and bearing plates, support loose ground materials on or against the mine roof, rib, and/or floor. Surface Control products include a variety of different shape, thickness, and length sections of both metal and non-metal materials.

A6.2 Surface Control products shall be identified with manufacturer’s identification where practical and where the manufacturing process contributes to the stamped product identification.

A6.3 Non-steel geogrids used as surface control shall meet the test standards in D6637 “Standard Test Method for Determining Tensile Properties of Geogrids by the Single or Multi Rib Tensile Method”.

APPENDIXES

(Nonmandatory Information)

X1. SELECTING APPROPRIATE GRADE RATING FOR BEARING PLATES AND HEADER PLATES

X1.1 The establishment of grade increments for bearing plates and header plates described in 7.4.1 enables the purchaser to select the appropriate relationship between the performance characteristics of the bolts and plates that is effective for the particular rock and ground conditions at the site of intended use.

X1.2 After determining the desired relationship between the grade rating of the plate and the minimum yield load for the grade and diameter of the bolt, the purchaser can order under this specification an appropriate grade rating for the bearing plate or header plate.

X2. EXPANSION SHELL TYPES

X2.1 Expansion shells are generally of two types. The first type is self-supporting by some means integral to the shell, such as a bail. The second type requires support to remain in position during installation until anchored. This type may use support such as special nuts on the thread or plastic sleeves,

although other means of support may be used. These support devices (bail, support nuts, etc.) should be of a special design that is capable of supporting the shell during installation but should not interfere with the proper tensioning of the bolt after the shell is anchored.

SUMMARY OF CHANGES

Committee F16 has identified the location of selected changes to this standard since the last issue (F432-10) that may impact the use of this standard.

- (1) **1.1** – Added “expandable rock bolts”.
- (2) **3.1** – Added definition for “discontinuous turn”.
- (3) **3.1** – Added definition for “expandable rock bolt”.
- (4) **3.1.9** – Edited expansion shell definition for clarity on mechanical anchorage per “Affirmative with Comment” from Sharp during Ballot number F16(01-10).
- (5) **3.1.12** – Edited definition **3.1.12** to exclude inflatable friction stabilizers since expandable rock bolts were added as a separate definition in Section **3**.
- (6) **3.1.28** – Edited definition for wedge to remove the word “or” as editorial change.
- (7) **3.1.28** – Edited definition for wedge to include reference to types of wedge assemblies typically used.
- (8) **5.12** – Added reference to Grade 50 material to distinguish the types of materials for the referenced designated bolt types.
- (9) **7.15** – Edited Cable Bolt mechanical properties to correctly require a minimum breaking strength rather than a maximum breaking strength.
- (10) **7.16** – Added mechanical properties reference for expandable rock bolts to Section **7**.
- (11) **8.3.2** – Added external thread specification tolerances.
- (12) **8.3.2** – Added note for exception for variable thread length specifications.
- (13) **8.4–8.9** – Editorial - Added headings for clarity to Section **8** for washers, bearing and header plate requirements, general components, and nuts.
- (14) **8.10** – Added dimensions of expandable rock bolt section.
- (15) **9.2** – Added references to expandable rock bolts.
- (16) **10.16** – Added tests for expandable rock bolts including two figures showing test setup alternatives.
- (17) **15.13** – Edited with note to explain “during” and “after” installation.
- (18) **15.13.1** – Edited to include identification of cable sections without wedge grip assemblies.
- (19) **15.14** – Added identification of expandable rock bolts.
- (20) **Table 5** – Edited to remove unnecessary parentheses.
- (21) **Fig. 1** – Revised with increased bolt flange thickness to make length measurement more clearly defined.
- (22) **Fig. 1** – Revised Note 6 to specify effective thread length for bolts with altered threads as noted in revised section **8.3.2**.
- (23) **Fig. 1** – Added Note 8 for effective thread length.
- (24) **Fig. 2** – Revised Note 2 to specify effective thread length for bolts with altered threads.
- (25) **Fig. 2** – Revised thread length on threaded slotted bars to new 3-³/₄ in. effective thread length specification as noted in revised section **8.3.2**.
- (26) **Fig. 2** – Added Note 5 for effective thread length.
- (27) **Table 10** – Edited Note D to designate full dimension and special dimension bar type markings.
- (28) **Table 10** – Added Note G to reference timing of Note D changes to markings.
- (29) **Table 12** – Revised title to include reference to expandable rock bolts.
- (30) **Annex A2** – Removed reference to only Grade 60 to include all bar grades noted in **A615/A615M**.
- (31) **Annex A3** – Edited Note **Note A3.1** to include general grout mixtures, not just grout cartridges.
- (32) **Annex A3** – Edited **A3.1.3** to include general grout mixtures, not just grout cartridges.
- (33) **Annex A3** – Edited **A3.2.1.2** to include general grout mixtures that don’t require additional mixing as would multi-component grout cartridges.
- (34) **Annex A3** – Edited section **A3.4.1, A3.4.1.2, and A3.4.1.3** to include general grout chemical mixtures that don’t require additional mixing as would multi-component grout cartridges.
- (35) **Annex A5** – Edited **A5.2** to allow for self-drilling bolts to be identified during the installation process with reference Note added.
- (36) **Annex A6** – Added annex for Surface Control products for mine applications.
- (37) **A6.3** – Added specification reference for test standards for non-steel geogrids.

ASTM International takes no position respecting the validity of any patent rights asserted in connection with any item mentioned in this standard. Users of this standard are expressly advised that determination of the validity of any such patent rights, and the risk of infringement of such rights, are entirely their own responsibility.

This standard is subject to revision at any time by the responsible technical committee and must be reviewed every five years and if not revised, either reapproved or withdrawn. Your comments are invited either for revision of this standard or for additional standards and should be addressed to ASTM International Headquarters. Your comments will receive careful consideration at a meeting of the responsible technical committee, which you may attend. If you feel that your comments have not received a fair hearing you should make your views known to the ASTM Committee on Standards, at the address shown below.

This standard is copyrighted by ASTM International, 100 Barr Harbor Drive, PO Box C700, West Conshohocken, PA 19428-2959, United States. Individual reprints (single or multiple copies) of this standard may be obtained by contacting ASTM at the above address or at 610-832-9585 (phone), 610-832-9555 (fax), or service@astm.org (e-mail); or through the ASTM website (www.astm.org). Permission rights to photocopy the standard may also be secured from the Copyright Clearance Center, 222 Rosewood Drive, Danvers, MA 01923, Tel: (978) 646-2600; <http://www.copyright.com/>