

Standard Test Method for Access Depth Under Furniture of Vacuum Cleaners¹

This standard is issued under the fixed designation F420; the number immediately following the designation indicates the year of original adoption or, in the case of revision, the year of last revision. A number in parentheses indicates the year of last reapproval. A superscript epsilon (ϵ) indicates an editorial change since the last revision or reapproval.

1. Scope

1.1 This test method covers the measurement of the operational ability of the vacuum cleaner, expressed as the access depth for a given furniture clearance above the floor.

1.2 This test method can be used in testing household and commercial vacuum cleaners.

1.3 The values stated in inch-pound units are to be regarded as standard. The values given in parentheses are mathematical conversions to SI units that are provided for information only and are not considered standard.

1.4 *This standard does not purport to address all of the safety concerns, if any, associated with its use. It is the responsibility of the user of this standard to establish appropriate safety and health practices and determine the applicability of regulatory limitations prior to use.*

2. Summary of Test Method

2.1 The carpet nozzle is inserted under a horizontal rod and the access depth is measured from the front of the rod.

3. Significance and Use

3.1 This test method is intended to provide a means of evaluating the effective cleaning depth under furniture.

3.2 Results of testing by this test method can be used as a basis for specifications on cleaning under furniture.

4. Apparatus

4.1 A 0.75-in. (19-mm) diameter rod, mounted horizontally in a suitable supporting device to provide heights under the rod from 0 to 10.0 in. (0 to 254 mm) in increments of 0.5 in. (12.7 mm).

4.2 A device for measuring access depth, (in inches or millimetres) horizontally from the face of the horizontal bar in 4.1.

4.3 *Voltage Regulator System*, to control the input voltage to the vacuum cleaner. The regulator system must be capable of maintaining the vacuum cleaner's rated voltage $\pm 1\%$ and rated frequency having a wave form that is essentially sinusoidal with 3 % maximum harmonic distortion for the duration of the test.

4.4 *Voltmeter*, to measure input voltage to the vacuum cleaner, to provide measurements accurate to within $\pm 1\%$.

5. Sampling

5.1 The access depth under furniture shall be established on three samples.

6. Preparation of Apparatus

6.1 Prepare the apparatus as shown in Figs. 1-3.

7. Procedure

7.1 *Upright Vacuum Cleaners* (Fig. 1):

7.1.1 Place the upright vacuum cleaner in its most advantageous position for cleaning under furniture. Operate the vacuum cleaner at the vacuum cleaner's nameplate rated voltage $\pm 1\%$ and rated frequency ± 1 Hz with the nozzle height in the lowest cleaning position on a bare floor surface.

7.1.1.1 For vacuum cleaners with dual nameplate voltage ratings, conduct the test method at the highest voltage.

7.1.2 The access depth is the distance (in inches or millimetres) measured from the front of the 0.75-in. (19-mm) diameter rod (when in contact with the highest component of the vacuum cleaner) to the most advanced point of the inlet of the nozzle.

NOTE 1—If the access depth is influenced by the cleaner bag, no pressure is to be applied to the handle or the bag to reduce the height.

NOTE 2—The vacuum cleaner must be energized, if a soft bag is present, as the inflation changes the working height of the handle when it is in its lowest position. If there is no soft bag, or no inflation possible, there is no reason to energize the cleaner as the test is conducted on a bare floor surface and the nozzle suction will be at a minimum and have little effect on the nozzle down-force.

7.1.3 Measure the access depth for heights from 0 to 10 in. (0 to 254 mm) in 0.5-in. (12.7-mm) increments. If full insertion of the cleaning mechanism occurs before 10.0 in. (254 mm), record this height. Cleaning mechanism refers to all of the parts from the vacuum cleaner nozzle to and including the handle grip.

¹ This test method is under the jurisdiction of ASTM Committee F11 on Vacuum Cleaners and is the direct responsibility of Subcommittee F11.20 on Performance (Test Methods).

Current edition approved Nov. 1, 2014. Published November 2014. Originally approved in 1975. Last previous edition approved in 2009 as F420 – 04 (2009). DOI: 10.1520/F0420-04R14.

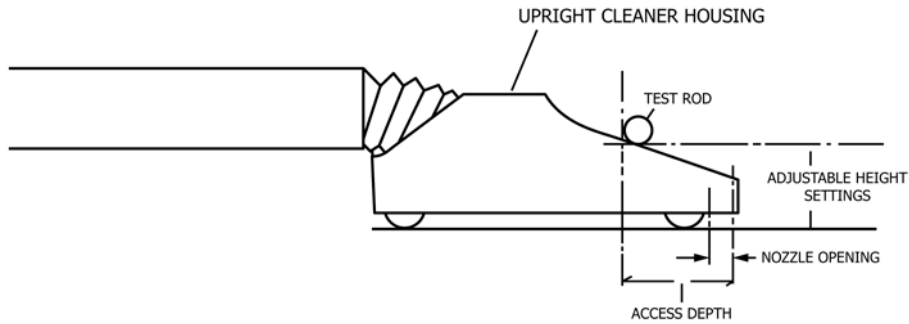

FIG. 1 Access Depth for Upright Vacuum Cleaners

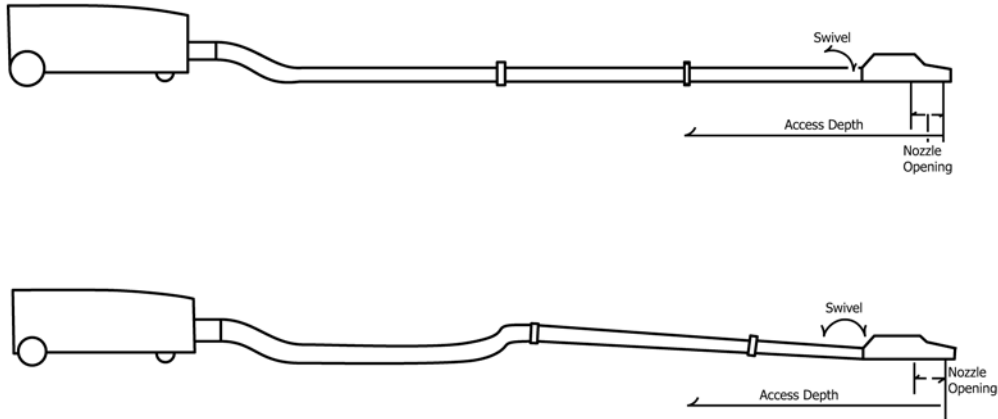

FIG. 2 a, b Access Depth for Combination and Canister Vacuum Cleaners (Nozzle Perpendicular to Vacuum Cleaner)

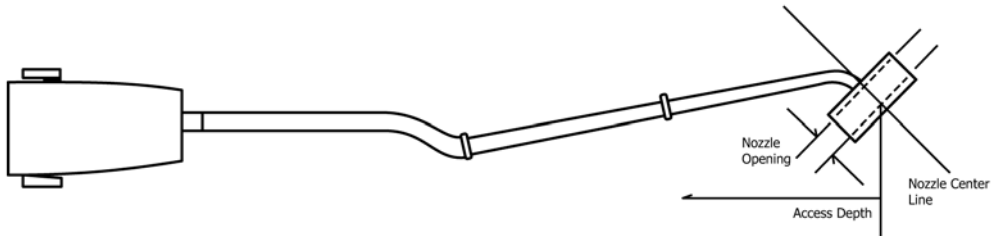

FIG. 3 Access Depth for Combination and Canister Vacuum Cleaners (Nozzle Not Perpendicular to Vacuum Cleaner)

7.2 *Combination and Canister Vacuum Cleaners* (Fig. 2 and Fig. 3):

7.2.1 Place the combination or canister vacuum cleaner nozzle in its most advantageous position for cleaning under furniture. Operate the vacuum cleaner at the vacuum cleaner’s nameplate rated voltage $\pm 1\%$ and rated frequency ± 1 Hz with the nozzle in full contact with the bare floor surface or the lowest nozzle setting.

7.2.2 *Vacuum Cleaner Nozzle Perpendicular to Vacuum Cleaner* (Fig. 2)—The access depth is the distance (in inches or millimetres) measured from the front of the 0.75-in. (19-mm) diameter rod (when in contact with the highest component of the cleaning system) to the most advanced point of the inlet of the nozzle when the front edge of the nozzle is perpendicular to the vacuum cleaner in its most advantageous position for cleaning under furniture.

7.2.3 *Vacuum Cleaner Nozzle Not Perpendicular to Vacuum Cleaner* (Fig. 3)—The access depth is the distance (in inches or millimetres) measured from the front of the 0.75-in. (19-mm)

diameter rod (when in contact with the highest component of the cleaning system) to a line parallel to the rod and through the center line of the nozzle and front opening.

7.2.4 Measure the access depth for heights from 0 to 10 in. (0 to 254 mm) in 0.5-in. (12.7-mm) increments. If full insertion of the cleaning mechanism occurs before 10.0 in. (254 mm), record this height. Cleaning mechanism refers to all of the parts from the vacuum cleaner nozzle to and including the hose or wand grip.

8. Report

8.1 The report shall include a table and a plotted curve indicating the clearance above the floor (in inches or millimetres) and the access depth (in inches or millimetres).

9. Precision and Bias

9.1 No justifiable statements can be made on precision (or bias) of this test method since the method determines whether or not an attribute is present.

10. Keywords

10.1 access depth; furniture; vacuum cleaner

ASTM International takes no position respecting the validity of any patent rights asserted in connection with any item mentioned in this standard. Users of this standard are expressly advised that determination of the validity of any such patent rights, and the risk of infringement of such rights, are entirely their own responsibility.

This standard is subject to revision at any time by the responsible technical committee and must be reviewed every five years and if not revised, either reapproved or withdrawn. Your comments are invited either for revision of this standard or for additional standards and should be addressed to ASTM International Headquarters. Your comments will receive careful consideration at a meeting of the responsible technical committee, which you may attend. If you feel that your comments have not received a fair hearing you should make your views known to the ASTM Committee on Standards, at the address shown below.

This standard is copyrighted by ASTM International, 100 Barr Harbor Drive, PO Box C700, West Conshohocken, PA 19428-2959, United States. Individual reprints (single or multiple copies) of this standard may be obtained by contacting ASTM at the above address or at 610-832-9585 (phone), 610-832-9555 (fax), or service@astm.org (e-mail); or through the ASTM website (www.astm.org). Permission rights to photocopy the standard may also be secured from the Copyright Clearance Center, 222 Rosewood Drive, Danvers, MA 01923, Tel: (978) 646-2600; <http://www.copyright.com/>