



Standard Test Method for Determination of Gel Content of Crosslinked Polyethylene (PEX) Pipes and Tubing¹

This standard is issued under the fixed designation F3203; the number immediately following the designation indicates the year of original adoption or, in the case of revision, the year of last revision. A number in parentheses indicates the year of last reapproval. A superscript epsilon (ϵ) indicates an editorial change since the last revision or reapproval.

1. Scope

1.1 The gel content of pipe and tubing produced from crosslinked polyethylene plastics as described in Specification **F876** and other pipe or tubing standards is determined by extracting with solvents such as xylenes. A test method for quantitative determination of gel content is described herein. The method is applicable to PEX pipe and tubing of all densities, including those containing fillers, and provides correction for the inert fillers present in some of those compounds.

1.2 Continuous extraction (see definition in Section 3) is used in this method to test the gel content of crosslinked polyethylene specimens. Continuous extraction when used for testing gel content has the advantages of decreased the cost of testing, increased accuracy and consistency of results, and decreased test time. This is because extraction with a pure solvent is more efficient than extraction with a partially saturated solvent.

1.3 While extraction tests may be made on articles of any shape, this test method is applicable for determining the gel content of crosslinked polyethylene pipes and tubing.

1.4 This test method makes use of xylenes or alternative solvents which have lower toxicity than xylenes. The alternative solvents are also potentially beneficial from an economic and environmental viewpoint. **Xylenes are used for referee tests.**

1.5 The values stated in SI units are to be regarded as standard. The inch-pound units in brackets are for information only

1.6 *This standard does not purport to address all of the safety concerns, if any, associated with its use. It is the responsibility of the user of this standard to establish appropriate safety and health practices and determine the applicability of regulatory limitations prior to use.*

¹ This test method is under the jurisdiction of ASTM Committee **F17** on Plastic Piping Systems and is the direct responsibility of Subcommittee **F17.40** on Test Methods.

Current edition approved Aug. 1, 2016. Published September 2016. DOI: 10.1520/F3203-16

2. Referenced Documents

2.1 ASTM Standards:²

D883 Terminology Relating to Plastics

D1603 Test Method for Carbon Black Content in Olefin Plastics

D2765 Test Methods for Determination of Gel Content and Swell Ratio of Crosslinked Ethylene Plastics

D7567 Test Method for Determining Gel Content in Crosslinked Ethylene Plastics Using Pressurized Liquid Extraction (Withdrawn 2015)³

E691 Practice for Conducting an Interlaboratory Study to Determine the Precision of a Test Method

F876 Specification for Crosslinked Polyethylene (PEX) Tubing

2.2 ISO Standard:⁴

ISO 10147 Pipes and Fittings Made of Crosslinked Polyethylene (Pe-X) – Estimation of the Degree of Crosslinking by Determination of the Gel Content

3. Terminology

3.1 Terms as shown in Terminology **D883** are applicable to this test method.

3.2 Definitions of Terms Specific to This Standard:

3.2.1 *continuous extractor, n*—test apparatus for performing a continuous extraction.

3.2.1.1 *Discussion*—Soxhlet, Knofler-Bohm, and Kumagawa extractors are examples of continuous extractors. A continuous extractor has three main components which are a boiling flask or vessel for the solvent, a condenser, and a siphon cup. There are various designs for the siphon cup; the Soxhlet, Knofler-Bohm, and Kumagawa designs are the most common.

² For referenced ASTM standards, visit the ASTM website, www.astm.org, or contact ASTM Customer Service at service@astm.org. For *Annual Book of ASTM Standards* volume information, refer to the standard's Document Summary page on the ASTM website.

³ The last approved version of this historical standard is referenced on www.astm.org.

⁴ Available from International Organization for Standardization (ISO), ISO Central Secretariat, BIBC II, Chemin de Blandonnet 8, CP 401, 1214 Vernier, Geneva, Switzerland, <http://www.iso.org>.

3.2.2 *continuous extraction, n*—an extraction performed in a continuous extractor where a solvent (normally xylenes) is heated in a vessel and boils forming vapors, the vapors rise and condense on a condenser to form droplets, the droplets fall into a cup where one or more specimens are placed, there the solvent in the tray dissolves some of the un-crosslinked polyethylene in the specimens, and when the cup holding the specimens is filled with solvent, the solvent now containing some of the un-crosslinked polyethylene drains out through a siphon tube back into the vessel where it started. The solvent and the sample specimens in the cup are kept warm by solvent vapor rising toward the condenser. The extraction steps repeat automatically and continuously as long as heat is applied to the vessel holding the solvent. Because only the solvent evaporates and not the material dissolved in it, the concentration of un-crosslinked polyethylene in the boiling solvent increases, while the concentration of un-crosslinked polyethylene in the specimens continually decreases.

3.2.3 *gel content, n*—the percentage by mass of polymer insoluble in a specified solvent after extraction under the specified conditions.

4. Summary of Test Method

4.1 Specimens of the crosslinked ethylene plastic are prepared, weighed and then extracted using a heated extraction solvent in a continuous extractor for the time designated by the procedure. After extraction, the specimens are removed from the continuous extractor, dried, and weighed as directed. The gel content is calculated using the final and initial specimen weights as directed in the calculations section of this test method.

5. Significance and Use

5.1 Many important properties of crosslinked ethylene plastics vary with the gel content. Hence, determination of the gel content provides a basis for controlling production processes and a means of establishing the quality of finished products.

5.2 Extraction tests permit verification of the proper gel content of any given crosslinked ethylene plastic and they also permit comparison between different crosslinked ethylene plastics, including those containing fillers, provided that, for the latter, the following conditions are met:

5.2.1 The filler is not soluble in the solvent used in this method at the extraction temperature.

5.2.2 The amount of filler present in the compound either is known or can be determined.

5.2.3 Sufficient crosslinking has been achieved to prevent migration of filler during the extraction. It has been found that, at gel content above 30 %, the solvent remains clear and free of filler.

5.3 Since some oxidative degradation of the material and solvent may occur at the reflux temperature of the solvents, a suitable antioxidant is added to the solvent to inhibit such degradation.

5.4 This test method is normally used for specimens consisting of an equal representation of the entire cross section of the product, but may also be used to examine specific portions

of a product for differences in extent of cross-linking when compared to either a product standard or another sample.

5.5 This test method is intended for testing crosslinked polyethylene compounds that are not hygroscopic. If compounds that are hygroscopic are tested using this method, specimen conditioning before and after extraction is required.

5.6 This standard differs from test methods Test Methods **D2765**, and Test Method **D7567** which also describe procedures for determining the gel content of crosslinked polyethylene. It allows for the use of naphthenic blend or isoparaffin solvent as an alternative to xylenes. Xylenes are the only solvent allowed to be used for referee tests. The preferred method of sample preparation in this standard is to use a lathe to create thin ribbons of PEX material. This standard requires the use of a continuous extractor in order to provide consistent results and to allow for reliable solvent re-use. Specialized specimen holders are used to minimize variability resulting from loss of specimen particles.

NOTE 1—Pressurized extraction techniques have been found to yield useful results in a shorter time frame, however not all grades of PEX tolerate the elevated extraction temperatures without substantial degradation. For this reason pressurized extraction techniques are recommended for control tests only if it is possible to determine that the crosslinked matrix of the PEX does not break down at the temperature of extraction

6. Conditioning

6.1 *Conditioning*—Conditioning of the test specimens is not required, unless specified by the manufacturer of the material being sampled.

6.2 *Test Conditions*—Test conditions do not affect results, with the exception of atmospheric pressure. Conduct tests in a laboratory with atmospheric pressure greater than 80 kPa (less than 6000 ft above average sea level).

NOTE 2—The altitude above sea level of the lab will influence the atmospheric pressure, which in turn will affect the boiling temperature of the solvent used and the rate at which it will be able to extract un-crosslinked polyethylene from the matrix.

7. Apparatus

7.1 *Continuous Extractor*, of the following general type, as illustrated in **Fig. 1**. Further information regarding possible sources of components is included in the **Appendix X3**.

7.1.1 *Boiling Flask*, with a ground-glass joint. The flask may be either flat bottom or round bottom. For one or two determinations at a time, the minimum appropriate size is 500-mL. For routine testing with several determinations at one time, but not exceeding six, a 2000-mL flask is suitable.

7.1.2 *Heating Mantle or Hot Plate*, to fit the flask and with sufficient heating capacity to boil the solvent used. If a flat bottom flask is used a hotplate shall be used instead of a heating mantle, and shall have sufficient heating capacity to boil the solvent used.

7.1.3 *Extractor Cup*, with a ground-glass joint to fit the boiling flask, a large mouth ground-glass joint on the top and sufficient capacity to hold specimen cages as described in **7.3.2**. The extractor cup shall be of a jacketed design so that the specimens are extracted at as near as possible to the boiling temperature of the solvent. The extractor cup and the boiling

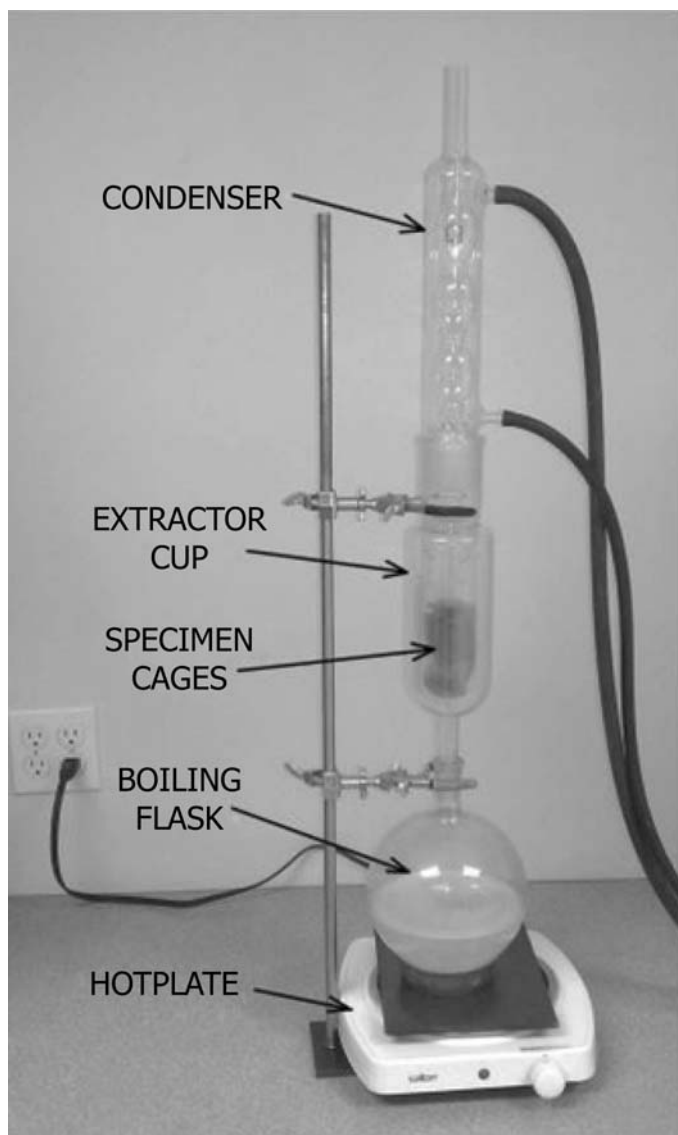

FIG. 1 Continuous Extractor

flask must be of mated capacity, as the boiling flask must have sufficient solvent in to safely be used as the extractor cup fills and drains. The extractor cup will be described with different names by laboratory glassware suppliers. These names include modified Soxhlet extractor, jacketed Soxhlet extractor, and Knofler-Bohm extractor. Review appendix X3.3 for supplier information.

7.1.4 *Reflux Condenser*, with ground-glass joint to fit into the extractor cup. This will typically be an Allihn or Dimroth condenser.

7.1.5 *Ring Stand and Appropriate Clamps*—

7.2 *Lathe, Drill Press, Plane or Planer*, suitable for reducing the sample to a thickness of 0.15 to 0.05 mm. A bench top lathe is preferred, although any procedure which will produce a sample of the required fineness without generating excessive heat is acceptable. Appendix X2 presents examples of devices suitable for sample preparation.

7.3 *Specimen Holders or Cages*:

7.3.1 *Specimen Holders*, of the general type illustrated in Fig. 2, machined aluminum with an internal volume of 6 to 7 cm³. The recommended design consists of two end caps and a spacer ring. The end caps shall be held together either by rare earth (samarium cobalt) magnets or a threaded connection to the spacer ring. The end caps shall have US No. 150 stainless steel wire mesh nested inside of the openings. The wire mesh is held between the spacer ring and the end caps to prevent specimen particles from escaping when the specimen holder is closed. The exposed surface area of the wire mesh in the end caps shall be a minimum of 11 cm². Individual specimen holders are identified by an engraved number or letter on the end caps. Specimen holders are reusable. Construction drawings for suitable specimen holders are available in Appendix X1.

7.3.2 *Specimen Cages*, made from U.S. No 150 stainless steel wire cloth. Prepare specimen cages by cutting pieces of stainless steel wire cloth measuring 80 by 50 mm (3 by 2 in.). Fold these in half to form rectangles measuring approximately 40 by 50 mm (1 ½ by 2 in.) Fold two sides of these rectangles closed by folding at the edges about 6 to 7 mm (¼ in.). In this manner, cages open at the top is obtained. Specimen cages may be reused several times provided that they are completely free of any polymer residue and do not have holes in them that would allow specimen particles to escape.

7.4 *Oven*, capable of heating specimen holders to 150°C (300°F) with temperature indication. This oven shall be of such construction and design to maximize air circulation. Convection toaster ovens sold for kitchen use have been found to be adequate provided they are used in a fume hood. Alternatively a vacuum oven may be used.

7.5 *Analytical Balance*, , minimum capacity of 100 g and capable of weighing to ± 0.0001 g.

7.6 *Wood Block*, 62 mm (2½ in.) by 37 mm (1½ in.) by 37 mm (1½ in.).

7.7 *Timer*, capable of timing intervals up to 10 hours, accurate to ± 30 s per hour or better, and with an audible alarm at the completion of the timed interval.

8. Reagents

8.1 *Extraction solvent*, xylenes are the preferred solvent and must be used for referee tests; however any one of the following solvents may be used for control tests:

8.1.1 *Naphthenic hydrocarbon blend*, boiling range 113 to 145°C. See Appendix X4.

8.1.2 *Isoparaffin solvent*, boiling range 155 to 180°C. See Appendix X4.

8.1.3 *Xylenes*, ACS reagent grade, boiling point 138 to 141°C.

8.1.4 Comparison tests using xylenes and any alternative solvent must be made. Gel content percentage values obtained using alternatives to xylenes tend to be 1.0 and 3.0% higher than those obtained with xylenes.

8.2 *Antioxidant*, the following or equivalent phenolic antioxidant shall be used in combination blends or by themselves. The antioxidants selected may be obtained from commercial

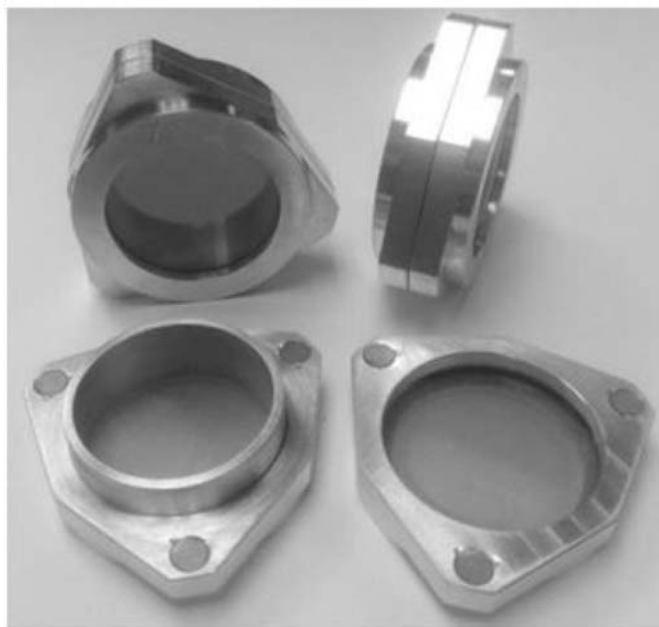

FIG. 2 Specimen Holder

suppliers and are not required to be reagent grade, as there is no expectation that minor impurities will influence results:

8.2.1 2,2'-methylene-bis(4-methyl-6-tertiary butyl phenol) (CAS#119-47-1)

8.2.2 Tetrakis-(methylene-(3,5-di-(tert)-butyl-4- hydrocinamate))methane (CAS# 6683-19-8)

8.2.3 1,3,5-trimethyl-2,4,6-tris(3,5-di-tert-butyl-4- hydroxybenzyl)benzene (CAS #:1709-70-2)

8.2.4 1,3,5-tris(3,5-di-tert-butyl-4-hydroxybenzyl)-1,3,5-triazine-2,4,6(1h,3h,5h)-trione (CAS# 27676-62-6)

9. Safety Precautions

9.1 The solvents used for extractions are toxic and flammable and as such must be handled carefully. Use only in a ventilated hood. Check the effectiveness of the hood before starting tests. Keep away from ignition sources. Do not inhale the vapors. Excessive inhalation of the vapors may cause dizziness or headache, or both. Wash hands after use. Chronic exposure may affect target organs.

NOTE 3—In the event of excessive inhalation, seek fresh clean air. Consult product safety data sheets for first aid and emergency instructions.

NOTE 4—Naphthenic hydrocarbon blend and isoparaffin solvents have been reported to have milder health effects than xylenes based on animal studies. As a result these solvents should be considered as an alternative to xylenes, especially in routine quality control or monitoring tests.

9.2 Inspect the continuous extractor for signs of wear or damage before each use. A continuous extractor may be tested prior to its first use and after any repair with water instead of flammable solvent to make sure that no leaks are present.

9.3 During tests, the continuous extractor will become hot enough to cause burns to bare skin. Avoid touching hot surfaces with bare hands.

9.4 Follow all manufacturers' safety instructions when using lathes and other power tools for sample preparation.

10. Test Specimens

10.1 Test at least two specimens per sample for referee tests, each containing 0.250 ± 0.015 g of polymer shavings or ribbons weighed to the nearest 0.0001 g. For routine quality control or monitoring tests, a single specimen may be prepared from each sample tested.

10.2 From sampled products make shavings or ribbons of 0.17 to 0.08 mm (0.007 to 0.003 in.) thickness for test specimens. Do not allow any fine particles that would pass through a 60-mesh sieve among the shavings.

NOTE 5—The thickness of the shavings should be as consistent as possible, because thinner shavings will oxidize more rapidly during testing while thicker shavings will take longer for a complete extraction of un-crosslinked polyethylene.

10.3 Prepare test specimens so they are homogenous and consist of an equal representation of the entire thickness of the product unless specific portions of the product are being examined for insufficient cross-linking. Specimens prepared from cross-linked polyethylene pipe or tubing must consist of an equal mixture of representative material from the entire thickness of the pipe or tubing wall unless otherwise specified.

10.4 Only prepare test specimens from samples of material with no obvious surface moisture or foreign material present. Pipes with non-PEX co-extruded layers shall have these coextruded layers removed prior to preparation of specimens.

11. Procedure

11.1 Load specimen holders or specimen cages as follows:

11.1.1 To load a specimen holder:

11.1.1.1 Remove one end cap from a specimen holder and visually inspected it to ensure that the interior is clean. Any specimen holder observed to be dirty shall not be used for this test method until cleaned.

11.1.1.2 Place the wood block vertically on the analytical balance to keep the magnets in the specimen holder from influencing readings of mass. Place the specimen holder with one end cap removed on the block on the analytical balance and zero the balance.

11.1.1.3 Place 0.250 ± 0.015 g of the prepared sample into the specimen holder. Record the weight of the specimen (W_1) to the nearest 0.0001 g. Carefully put the second end cap onto the specimen holder.

NOTE 6—Specimen holders have the advantage of ensuring that the specimens are extracted in the most consistent way possible while greatly reducing the risk of specimen particles escaping or being compacted together during the test procedure. Using specimen holders as an alternative to the wire mesh cages may limit the number of specimens that are extracted at the same time due to the sizes of extractor cups available.

11.1.2 To load a specimen cage:

11.1.2.1 Place the open cage on the analytical balance and zero the balance. Place 0.250 ± 0.015 g of the prepared sample into the specimen cage. Record the weight of the specimen in the cage (W_o) to the nearest 0.0001 g. Fold over the open side of the cage and staple the edges to close the cage. Avoid as much as practical any compaction of the specimens in the cages.

11.1.2.2 Record the weight of the closed cage and the specimen (W_3) to the nearest 0.0001 g. Identify the specimen cages by marking them with an ink that is insoluble to xylenes, or by attaching a metal tag to the cage.

11.1.2.3 Specimen cages have the advantage of being inexpensive and simple to make. If the specimen consists of long continuous ribbons, the risk of particles escaping is very low and if the specimen cages are prepared carefully the risk of specimen compaction can be mitigated.

11.2 Set-up the continuous extractor (see Fig. 1) and add solvent (8.1) into the extraction vessel as required:

11.2.1 If the continuous extraction apparatus is set-up from previous tests, confirm that there is adequate solvent remaining in it and that the solvent is not overly saturated with extracted polyethylene (appears as a thick slurry) or has not become extremely discolored (brown). The volume of solvent in the continuous extractor must be at least twice the maximum volume that could be held in the extractor cup.

11.2.2 Use xylenes as the extraction solvent for referee tests.

11.2.3 If fresh extraction solvent is required, fill the continuous extractor with solvent (at least twice the maximum volume that can be held in the extractor tray or cup) and dissolve $0.5 \pm 0.1\%$ by weight antioxidant (8.2) in the solvent to inhibit oxidation.

11.2.4 There must be between 25% and 75% of the boiling flask's total volume of extraction solvent in the boiling flask at any time during the extraction. For example, an extractor cup with a capacity of 200-mL of extraction solvent will require 450 to 750-mL of extraction solvent in a 1000-mL boiling flask.

11.2.5 Place two or three boiling chips in the boiling flask with the extraction solvent to prevent "bumping."

11.3 Pre-heat the continuous extractor by turning the heater mantle or hot plate on. Turn on the cooling water supply to the condenser.

11.3.1 Wrapping the boiling flask and extractor cup part of the continuous extractor with aluminum foil will decrease the amount of time required to heat up the extractor, and is therefore strongly recommended, though not required.

11.4 Place the specimen holders or cages in the continuous extractor by quickly lifting the condenser, lowering the specimens into the extractor cup, and then replacing the condenser. The specimen cages or holders must all be fully immersed when the extractor cup is full of solvent. No more than eight (8) specimen cages shall be placed in a 200-mL capacity extractor cup at once. No more than six (6) specimen cages shall be placed in a 145-mL capacity extractor cup at once.

11.5 Heat the boiling extraction solvent enough to ensure adequate changes of solvent in the extractor cup. There must be a minimum of eight solvent changes an hour in the extractor cup. There is no maximum number of changes per hour.

11.5.1 Xylenes require 336 joules per gram to evaporate, so a 500 Watt heater mantle working at 50% efficiency will evaporate 43 grams per minute so a 200-mL capacity extractor cup will fill up and drain every 5 min.

11.6 Extract the specimens for $5.0 \text{ h} \pm 5 \text{ min}$. Start timing the extraction when the first drops of solvent fall from the condenser onto the specimens. If the extraction is interrupted and restarted, the total time of extraction shall be $5.0 \text{ h} \pm 5 \text{ min}$ of time with drops of solvent falling on the specimens.

11.7 After the extraction time has elapsed turn off the heater.

11.8 Remove the specimen holders or cages from the continuous extractor and place them in a covered beaker to cool and drain off excess solvent for a minimum of five minutes. Return any solvent recovered to the continuous extractor. Gently blow off the specimen holders or cages with compressed nitrogen, or place them on a lint free cloth briefly to assist in removal of solvent to aid subsequent drying.

11.9 Place the specimen holders or cages in an oven preheated to 120°C (250°F). Dry the specimen holders or cages in the oven to a constant weight. Avoid excessive drying time and temperature as the specimens may char. Normally 40 minutes of drying time is sufficient. Cool the specimen holders or cages.

11.10 Determine the final weight of the specimens:

11.10.1 Carefully open a closed specimen holder or cage and empty the contents onto a zeroed weighing dish on the analytical balance. Record the weight of the specimen (W_p) to the nearest 0.0001 g. Repeat for each specimen.

11.10.2 Alternatively, if specimen cages are used and it is difficult to separate the specimen from the cage, record the weight (W_4) of each specimen cage with the specimen still in it, to the nearest 0.0001 g.

11.11 If extraction tests are regularly made, it is acceptable to leave the continuous extractor assembled and the extracting solvent (containing antioxidant as directed) reused until it turns brown and becomes saturated with extract. However, if there is any doubt about the values obtained with reused solvent, the test shall be repeated with fresh solvent. It is important to not allow the solvent to be mixed with other types of solvents or to become contaminated with any water.

11.11.1 *Discussion*—It has been reported that 100 to 200 specimens may be extracted with the same solvent using this method. After the solvent has become saturated, it may be filtered and distilled to be re-used.

12. Calculation

12.1 Calculate the gel content in percent as follows:
Gel Content, % = (weight of specimen after extraction / weight of original specimen) x 100% - % filler

$$\text{Gel Content} = \left(\frac{W_f}{W_o} \right) \times 100\% - F \quad (1)$$

where:

W_o = original weight of the specimen,

W_f = the weight of the specimen after extraction, $W_f = W_o - (W_3 - W_4)$, and

F = percentage filler (filler insoluble in extraction solvent used) in the polyethylene compound.

13. Report

13.1 Report the following information:

13.1.1 Complete identification of the compound,

13.1.2 Weight percent of filler in the compound if the material is filled. The weight percent filler is as identified by the compound's supplier or is determined by the Test Method **D1603**,

13.1.3 Percent gel content; the value for each specimen and the average for the sample,

13.1.4 Solvent used, duration of extraction and any pertinent sample preparation, and

13.1.5 Any unusual or abnormal behavior observed during the test.

14. Precision and Bias

14.1 The precision this test method is under investigation by a task group of Subcommittee F17.40 on Test Methods.

Anyone wishing to participate in this work may contact the Chairman of Subcommittee F17.40, at ASTM Headquarters.

14.2 *Precision*—The repeatability standard deviation for a single operator and for single specimen tests has been determined to be as shown in **Table 1**. All measurements were made using xylene as the extraction solvent and a 5 h extraction time. Both specimen holders and cages were utilized for the tests recorded.

14.3 An inter-laboratory study of this test method is being conducted and a complete precision statement is expected to be available during or before 2020.

14.4 *Bias*—No information can be presented on the bias of this test method for measuring the gel content of crosslinked polyethylene because no material having an accepted reference value is available.

NOTE 7—The precision of this test method is expected to be equal to or better than the precision of Test Methods **D2765** methods because this test method requires use of more precise weight measurement and continuous extraction which assures extraction with pure solvent. This significantly improves repeatability. As mentioned in Test Methods **D2765**, Note 2, the accuracy is 1 to 2% better using a Soxhlet Extractor. In general this method will have a bias in the results of 0 to 1% lower gel content measured than would be measured with Test Methods **D2765** Method A.

15. Keywords

15.1 crosslinked ethylene plastics; crosslinked polyethylene; gel content; Knofler-Bohm extractor; Kumagawa extractor; PEX pipes; PEX tubing; Soxhlet extractor

TABLE 1 Gel Content Precision

Sample ID	Average Gel Content, %	Standard Deviation, %	Number of Specimens	I_r , %
PEX-A #1	84.14	0.35	4	0.99
PEX-A #2	83.99	0.44	14	1.23
PEX-B #1	79.88	0.29	14	0.80
PEX-B #2	71.32	0.39	14	1.08

APPENDIXES

X1. CONSTRUCTION DRAWING SPECIMEN HOLDER

(Nonmandatory Information)

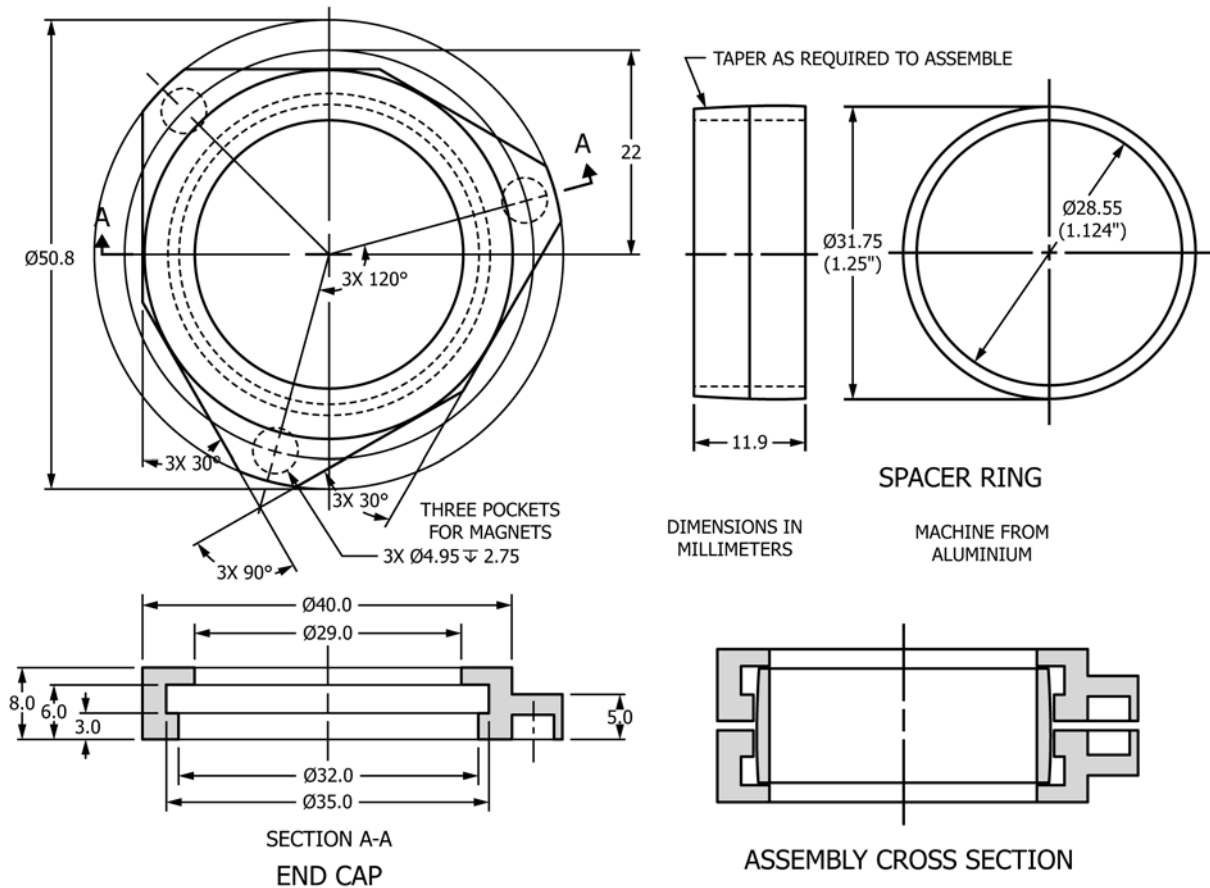

FIG. X1.1 Specimen Holder

X2. EXAMPLES OF SUITABLE DEVICES FOR SAMPLE PREPARATION

X2.1 The most suitable devices for sample preparation are small bench top metal lathes. Examples of these include:

Baileigh Industrial PL-712VS, variable speed bench top lathe,

Grizzly Industrial G4000 - 9 in. x 19 in. bench lathe

X2.2 The lathe may be set-up to create shavings using a parting tool or a right hand facing tool.

X2.3 Another option that may be considered is using a 3¼ in. electric hand planer. In this case the planer could be mounted to a frame of the user's construction, with a suitable guard installed to protect the user from the cutter blades while

allowing the end of a section of pipe to be fed into the blades with one hand while the other hand is used to operate the on/off trigger. Models are available from many suppliers. Feed rate will control shaving thickness.

X2.4 Finally samples may be prepared by drilling into the wall of the pipe, either parallel or perpendicular to the axis of the pipe. A drill press is the preferred tool for this approach. It is also important that the pipe wall be sufficiently thick to allow safe drilling, therefore it is not recommended to use a drill for sample preparation on pipes with wall thickness less than 13-mm (½ in.).

X3. CONTINUOUS EXTRACTOR PARTS

X3.1 Components of the continuous extractor used are available from a number of suppliers. The list of part numbers below is not exhaustive. Users of this standard are not prevented from purchasing apparatus of suitable design from other suppliers.

Example part numbers from various suppliers are provided below to assist users of this standard in selecting appropriate components for the continuous extractor used. Other suppliers of these parts exist and may be used.

X3.2 Condenser, Allinn Reflux

X3.2.1 These reflux condensers have a lower tapered drip tip joint and tubular chimney top.

Aldrich Part No.	Kimble Part No	Prism Part No.	Details Description
Z556270 Aldrich	456000-0022	PRG-1910-02	260 mm jacket length - 45/50 joint
Z556297 Aldrich	456000-0023	PRG-1910-03	300 mm jacket length - 55/50 joint

X3.3 Condenser, Allinn Reflux (also known as a Jacketed Soxhlet or Knofer-Bohm Extractor):

X3.3.1 The outer jacket provides heat exchange with a vapor envelope over inner extraction tube which has holes for rising vapor.

Aldrich Part No.	Prism Part No.	Details Description
Z564788 Aldrich	PRG-3575- 02	45/50 outer joint at top, 24/40 inner joint @ bottom, 40 mm I.D., 90 mm height, cap. 145 mL
Z564796 Aldrich	PRG-3575- 03	55/50 outer joint at top, 24/40 inner joint @ bottom, 50 mm I.D., 130 mm height, cap. 200 mL

Verrerie-Villeurbannaise Part Numbers:

Model EXTSOXHK500	Extractor, Soxhlet - Knofer-Bohm type, 500 mL capacity, female socket 60/46, male 29/32
Model EXTSOXHK250	Extractor, Soxhlet of Knofer-Bohm type, 250 mL capacity, female socket 45/40, male 29/32

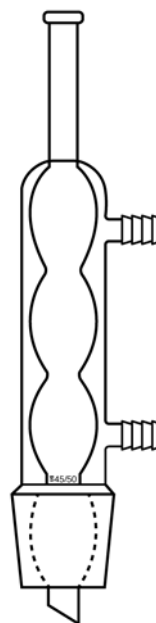

Lenz Part Numbers:

Cat. No. 5 3750 58	Extractor, Knofer-Bohm type, 500 mL capacity, <u>complete apparatus</u> including flask and condenser
Cat. No. 5 3750 49	Extractor, Knofer-Bohm type, 250 mL capacity, <u>complete apparatus</u> including flask and condenser

Carl Roth Part Numbers:

LE41.1	Extractor, Knofer-Bohm type, 500 mL capacity, female socket 60/46, male 29/32
LE40.1	Extractor, Knofer-Bohm type, 250 mL capacity, female socket 45/40, male 29/32

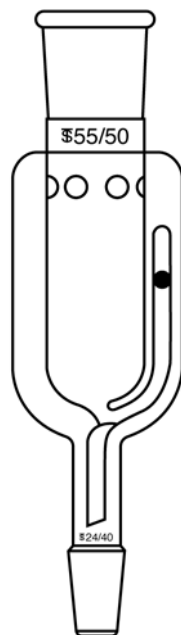

X4. ALTERNATIVE SOLVENTS

X4.1 A grade of naphthenic hydrocarbon blend which has been found to be satisfactory for this method is CBG Formula 83.

X4.2.1 Isopar G (boiling range 166 to 177°C).

X4.2.2 Soltrol 100 (boiling range 158 to 175°C).

X4.2 Isoparaffin solvents which are satisfactory for this test method are:

ASTM International takes no position respecting the validity of any patent rights asserted in connection with any item mentioned in this standard. Users of this standard are expressly advised that determination of the validity of any such patent rights, and the risk of infringement of such rights, are entirely their own responsibility.

This standard is subject to revision at any time by the responsible technical committee and must be reviewed every five years and if not revised, either reapproved or withdrawn. Your comments are invited either for revision of this standard or for additional standards and should be addressed to ASTM International Headquarters. Your comments will receive careful consideration at a meeting of the responsible technical committee, which you may attend. If you feel that your comments have not received a fair hearing you should make your views known to the ASTM Committee on Standards, at the address shown below.

This standard is copyrighted by ASTM International, 100 Barr Harbor Drive, PO Box C700, West Conshohocken, PA 19428-2959, United States. Individual reprints (single or multiple copies) of this standard may be obtained by contacting ASTM at the above address or at 610-832-9585 (phone), 610-832-9555 (fax), or service@astm.org (e-mail); or through the ASTM website (www.astm.org). Permission rights to photocopy the standard may also be secured from the Copyright Clearance Center, 222 Rosewood Drive, Danvers, MA 01923, Tel: (978) 646-2600; http://www.copyright.com/