



# Standard Specification for High-Purity Titanium Sputtering Target Used for Through-Silicon Vias (TSV) Metallization<sup>1</sup>

This standard is issued under the fixed designation F3166; the number immediately following the designation indicates the year of original adoption or, in the case of revision, the year of last revision. A number in parentheses indicates the year of last reapproval. A superscript epsilon ( $\epsilon$ ) indicates an editorial change since the last revision or reapproval.

## 1. Scope

1.1 This specification details the generic criteria requirements of high pure titanium sputtering targets used as thin film material for through-silicon vias (TSV) metallization in advance packaging.

1.2 Sputtering target purity, grain size, inner quality, bonding, dimension, and appearance specifications are included in this specification along with references for qualification test methods. Reliability, certification, traceability, and packaging requirements are also included.

### 1.2.1 Purity Requirements:

1.2.1.1 Metallic element impurities, and

1.2.1.2 Non-metallic element impurities.

### 1.2.2 Grain Size Requirements—Grain size.

### 1.2.3 Inner Quality Requirements—Internal defect.

### 1.2.4 Bonding Requirements:

1.2.4.1 Backing plate, and

1.2.4.2 Bonding ratio.

### 1.2.5 Configuration Requirements:

1.2.5.1 Dimension,

1.2.5.2 Tolerance, and

1.2.5.3 Surface roughness.

### 1.2.6 Appearance Requirements—Surface cleanliness.

1.3 The values stated in SI units are to be regarded as standard. No other units of measurement are included in this standard.

1.4 *This standard does not purport to address all of the safety concerns, if any, associated with its use. It is the responsibility of the user of this standard to establish appropriate safety and health practices and determine the applicability of regulatory limitations prior to use.*

<sup>1</sup> This specification is under the jurisdiction of ASTM Committee F01 on Electronics and is the direct responsibility of Subcommittee F01.17 on Sputter Metallization.

Current edition approved May 1, 2016. Published July 2016. DOI: 10.1520/F3166-16

## 2. Referenced Documents

### 2.1 ASTM Standards:<sup>2</sup>

**B209** Specification for Aluminum and Aluminum-Alloy Sheet and Plate

**B248** Specification for General Requirements for Wrought Copper and Copper-Alloy Plate, Sheet, Strip, and Rolled Bar

**E112** Test Methods for Determining Average Grain Size

**E1001** Practice for Detection and Evaluation of Discontinuities by the Immersed Pulse-Echo Ultrasonic Method Using Longitudinal Waves

**F1512** Practice for Ultrasonic C-Scan Bond Evaluation of Sputtering Target-Backing Plate Assemblies

**F1709** Specification for High Purity Titanium Sputtering Targets for Electronic Thin Film Applications

**F1710** Test Method for Trace Metallic Impurities in Electronic Grade Titanium by High Mass-Resolution Glow Discharge Mass Spectrometer

### 2.2 ASME Standard:

**Y14.5M** Dimensioning and Tolerancing<sup>3</sup>

## 3. Terminology

### 3.1 Definitions:

3.1.1 *backing plate, n*—plate used to support the sputtering material used in deposition processes.

3.1.1.1 *Discussion*—Assembling with the sputtering material by various bonding methods.

3.1.2 *sputtering target, n*—source material during sputter deposition processes; typically, a piece of material inside the vacuum chamber that is exposed to bombarding ions, knocking source atoms loose and onto samples.

3.1.2.1 *Discussion*—The sputtering target product can be classified as monolithic or assembly type according to the configurations as shown in Fig. 1.

<sup>2</sup> For referenced ASTM standards, visit the ASTM website, [www.astm.org](http://www.astm.org), or contact ASTM Customer Service at [service@astm.org](mailto:service@astm.org). For *Annual Book of ASTM Standards* volume information, refer to the standard's Document Summary page on the ASTM website.

<sup>3</sup> Available from American Society of Mechanical Engineers (ASME), ASME International Headquarters, Two Park Ave., New York, NY 10016-5990, <http://www.asme.org>.

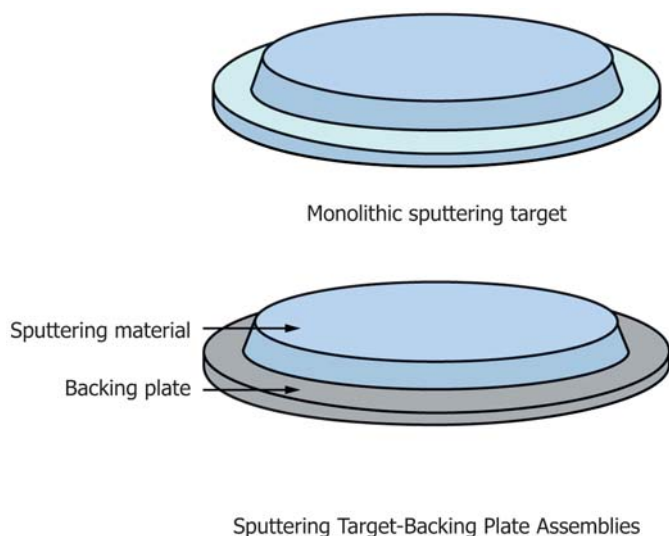

FIG. 1 Sputtering Target Configuration

3.2 Definitions of Terms Specific to This Standard:

3.2.1 finished product, *n*—for the purposes of this standard, a manufactured sputtering target ready for use.

3.2.2 material lot, *n*—for the purposes of this standard, material melted into one ingot and processed as one continuous batch in subsequent thermal-mechanical treatments.

4. Ordering Information

4.1 Advance packaging manufacturers may use this specification to specify required target performance to the supplier

when purchasing sputtering target. Target suppliers may also use this specification to specify material requirements to raw material suppliers.

4.2 Orders for pure titanium sputtering targets shall include the following:

- 4.2.1 Grade and special requirements concerning impurities, if required (Section 5),
- 4.2.2 Grain size, if required (Section 6),
- 4.2.3 Inner quality, if required (Section 7),
- 4.2.4 Bonding ratio, if required (Section 8),
- 4.2.5 Dimensions, Tolerance and Surface Roughness (Section 9),
- 4.2.6 Certification required (Section 14), and
- 4.2.7 Whether or not a sample representative of the finished product is required to be provided by the supplier to the purchaser.

5. Purity Requirement

5.1 Metallic Element Impurities:

5.1.1 Grades of titanium sputtering targets for through-silicon vias (TSV) metallization are defined in Table 1 based on typical metallic impurity content of the elements listed in the table. Impurity contents are reported in parts per million by weight (wt ppm). Additional elements may be analyzed and reported as agreed upon between the purchaser and the supplier.

5.1.2 Acceptable analysis methods and detection limits are specified in Specification F1709. Use Test Method F1709 to analyze the purity of titanium by high-mass resolution glow discharge mass spectrometer (GDMS).

TABLE 1 Suggested Titanium Sputtering Target Grades and Impurity Content Requirements

NOTE 1—Ti purity is 100 % subtract the sum of impurities contents listed in this table.

Element	Units	Test Method	Ti Purity, %	
			99.995 % (4N5)	99.999 % (5N)
Ag	ppmw	GDMS	≤0.2	≤0.2
Al	ppmw	GDMS	≤5.0	≤2.0
B	ppmw	GDMS	≤0.1	≤0.1
Ca	ppmw	GDMS	—	≤1.0
Co	ppmw	GDMS	≤1.0	≤0.1
Cr	ppmw	GDMS	≤5.0	≤1.0
Cu	ppmw	GDMS	≤2.0	≤1.0
Fe	ppmw	GDMS	≤15.0	≤7.0
K	ppmw	GDMS	≤0.1	≤0.1
Li	ppmw	GDMS	≤0.1	≤0.1
Mg	ppmw	GDMS	≤1.0	≤0.1
Mn	ppmw	GDMS	≤1.0	≤0.3
Mo	ppmw	GDMS	≤4.0	≤0.5
Na	ppmw	GDMS	≤0.2	≤0.1
Ni	ppmw	GDMS	≤5.0	≤0.5
Pb	ppmw	GDMS	≤2.0	≤0.1
Si	ppmw	GDMS	≤5.0	≤2.0
Sn	ppmw	GDMS	≤2.0	≤1.0
Th	ppmw	GDMS	≤0.001	≤0.001
U	ppmw	GDMS	≤0.001	≤0.001
V	ppmw	GDMS	≤1.0	≤1.0
W	ppmw	GDMS	≤1.0	≤0.5
Zn	ppmw	GDMS	≤1.0	≤0.5
Zr	ppmw	GDMS	≤5.0	≤1.0
Total amount	ppmw		≤50	≤10

5.1.3 For most metallic species, the detection limit by GDMS is on the order of 0.01 wt ppm. With special precautions, detection limits to sub-ppb levels are possible. Elements not detected will be counted and reported as present at the minimum detection limit (mdl).

5.1.4 Other analytical techniques may be used provided they can be proved equivalent to the methods specified and have mdl less than or equal to the specified methods.

5.1.5 Acceptable limits and analytical techniques for particular elements in critical applications may be agreed upon between the purchaser and the supplier.

*5.2 Nonmetallic Element Impurities:*

5.2.1 Nonmetallic element impurities that shall be analyzed and reported are carbon, hydrogen, nitrogen, oxygen, and sulfur. Maximum limits for nonmetallic impurities shall be as agreed upon between the purchaser and the supplier. Typically, nonmetallic impurities should be as low as shown in **Table 2**.

5.2.2 Acceptable analysis methods and detection limits are specified in Specification **F1709**. Elements not detected will be counted and reported as present at the mdl.

5.2.3 Other analytical techniques may be used provided they can be proved equivalent to the methods specified and have mdl less than or equal to the specified methods.

**6. Grain Size Requirement**

6.1 The average and the maximum grain size shall be as agreed upon between the purchaser and the supplier. The average and the maximum grain size are generally controlled within 50 and 100  $\mu\text{m}$ .

6.2 Average grain size shall be measured and reported in accordance with Test Methods **E112** or another equivalent method.

6.3 Maximum grain size shall be established by making an optical or scanning electron micrograph of a polished and etched specimen typical of the finished product. The magnification shall be calibrated to  $\pm 10\%$  of nominal using an appropriate gage. At least 50 grains shall be resolved in the micrograph. The maximum grain size is the diagonal measure of the largest titanium crystal visible in the field of view divided by the magnification.

6.4 Average grain size and maximum grain size can alternatively be established using computer-assisted image analysis methods. If image analysis methods are used, then the average grain size is defined as the mean value obtained from the grain diameter distribution data. The maximum grain size is defined

as the largest grain diameter recorded in the grain size distribution set. At least 50 grains shall be included in the image analysis data set.

**7. Inner Quality Requirement**

7.1 Internal defect such as inclusions and pores which affect sputtering film quality shall not exist inside the target. The supplier should promise the target inner quality by raw materials control and target fabricating methods.

7.2 Internal defects which are defined as discontinuities in the bulk material shall be measured and reported in accordance with Guide **E1001** or another equivalent method.

**8. Bonding Requirement**

8.1 *Backing Plate*—For the assembly sputtering target, aluminum alloy and copper alloy can be used as a backing plate for bonding. The backing plate materials should meet the requirements of Specifications **B209** or **B248**. Other backing plate material and requirements shall be agreed upon between the purchaser and the supplier.

8.2 Diffusion bonding is very commonly used in sputtering target-backing plate assembly. The bonding quality shall meet the requirements of **Table 3**.

8.3 The bonding ratio shall be measured and reported in accordance with Practice **F1512** or another equivalent method.

**9. Dimensions, Tolerance, and Surface Roughness Requirement**

9.1 Each product shall conform to an appropriate engineering drawing agreed upon between the purchaser and the supplier.

9.2 Nominal dimensions, tolerances, and other attributes shall be measured and reported in accordance with ASME Y14.5M or another equivalent method.

9.3 Normally, the sputtering surface roughness prepared by machining or polishing shall be less than 1.6  $\mu\text{m}$ .

**10. Appearance Requirement**

10.1 The target surface appearance shall be agreed upon between the purchaser and the supplier.

10.2 Surfaces shall be free of any contaminates such as dirt or oils that could adversely affect the performance of the material as agreed upon between the purchaser and the supplier.

**TABLE 2 Suggested Nonmetallic Impurity Requirement**

Element	Units	Test Method	Ti Purity, %	
			99.995 % (4N5)	99.999 % (5N)
C	ppmw	fusion and gas extraction/ infrared spectroscopy	$\leq 50$	$\leq 40$
H	ppmw	fusion and gas extraction	$\leq 10$	$\leq 10$
N	ppmw	fusion and gas extraction	$\leq 50$	$\leq 50$
O	ppmw	fusion and gas extraction/ infrared spectroscopy	$\leq 300$	$\leq 250$
S	ppmw	fusion and gas extraction/ infrared spectroscopy	$\leq 10$	$\leq 10$

**TABLE 3 Suggested Bonding Requirement<sup>4</sup>**

Bonding Method	Bonding Ratio	Single-Defect Area/the Whole Bonding Area
Diffusion bonding	≥98 %	≤1.5 %

<sup>4</sup>Other bonding method and bonding ratio request shall be agreed upon between the purchaser and the supplier.

## 11. Sampling Requirement

11.1 Analysis for target properties (including impurity, grain size, inner quality, bonding ratio, dimension and tolerances, and surface roughness and appearance) shall be performed on samples that are representative of the finished sputtering target.

11.1.1 Unless otherwise agreed upon between the purchaser and the supplier, impurity analyses for metallic and nonmetallic impurities shall be made by the supplier for one or more sample specimens that are representative of the production lot. These data shall be averaged to establish conformance with the grade designation (5.1), other metallic impurity limits (5.1), and the agreed upon limits for nonmetallic content (5.2).

11.1.2 Unless otherwise agreed upon between the purchaser and the supplier, grain size analyses shall be made by the supplier for one or more sample specimens after thermal-mechanical treatments for the lot of titanium material. These data shall be averaged to establish conformance with the grain size designation (6.1).

11.2 *Suggested Sampling Information*—See Table 4.

## 12. Traceability Requirements

12.1 It will be the responsibility of the target supplier to establish and maintain an incoming raw material certification, inspection, and traceability process, which will ensure that manufactured target components meet the requirements of this specification.

12.2 Every deliverable item shall have some scheme of identification on the exterior bag or box so that traceability is provided from the raw material supplier to the final finished, packaged product.

## 13. Reliability Requirements

13.1 Upon request, the manufacturer should provide sputtering reliability data accompanied by the sputtering qualification test. This typically involves lifetime testing of the sputtering target with desired film properties (usually kwh is used as

measurement unit). The spent target can be analyzed by profilometer to learn the left minimum thickness, h1, of the sputtering material as shown in Fig. 2. Normally, for safety, the h1 should be more than 2 mm.

## 14. Certification

14.1 The target supplier is responsible for defining, establishing, and executing a testing program for sputtering target based on the requirements outlined within this specification.

14.2 When required by the purchaser a certificate of analysis/compliance that documents the finished target shall be provided by the supplier.

14.3 The certificate of analysis/compliance shall state the manufacturer's or supplier's name, the supplier's lot number, the grade level, impurity levels, method of analysis (Section 5), and any other information as agreed upon between the purchaser and the supplier.

## 15. Packaging

15.1 Every target shall be packed as one single unit. Each piece shall be sealed by vacuuming inert gas to avoid contamination and oxidation and shall be packaged well with cushion material and enhanced structure to avoid damage.

15.2 The packaging shall have a label affixed that clearly identifies the product name (with purity grade and material), lot number, and any other necessary traceability characteristics (Section 12).

15.3 The packaging shall be capable of withstanding a storage period of target shelf-life, without the purity of the material being affected.

## 16. Keywords

16.1 high-purity titanium; sputtering target; TSV metallization

**TABLE 4 Suggested Sampling Requirement**

Measurement Item	Sampling Time	Sample Numbers	Notes
Impurities	After ingot cutting	1 or 2 pieces/lot	5.1
Grain size	After thermal-mechanical treatments	1 or 2 pieces/lot	6.1
Inner quality	After thermal-mechanical treatments	Each	7.1
Bonding ratio	After bonding	Each	8.2
Dimension and tolerances	Finished product	Each	9.1
Surface roughness	Finished product	Each	9.3
Appearance	Finished product	Each	10.1

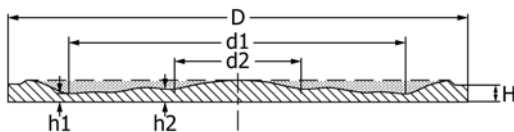

FIG. 2 Spent Target Configuration

ASTM International takes no position respecting the validity of any patent rights asserted in connection with any item mentioned in this standard. Users of this standard are expressly advised that determination of the validity of any such patent rights, and the risk of infringement of such rights, are entirely their own responsibility.

This standard is subject to revision at any time by the responsible technical committee and must be reviewed every five years and if not revised, either reapproved or withdrawn. Your comments are invited either for revision of this standard or for additional standards and should be addressed to ASTM International Headquarters. Your comments will receive careful consideration at a meeting of the responsible technical committee, which you may attend. If you feel that your comments have not received a fair hearing you should make your views known to the ASTM Committee on Standards, at the address shown below.

This standard is copyrighted by ASTM International, 100 Barr Harbor Drive, PO Box C700, West Conshohocken, PA 19428-2959, United States. Individual reprints (single or multiple copies) of this standard may be obtained by contacting ASTM at the above address or at 610-832-9585 (phone), 610-832-9555 (fax), or [service@astm.org](mailto:service@astm.org) (e-mail); or through the ASTM website ([www.astm.org](http://www.astm.org)). Permission rights to photocopy the standard may also be secured from the Copyright Clearance Center, 222 Rosewood Drive, Danvers, MA 01923, Tel: (978) 646-2600; <http://www.copyright.com/>