



# Standard Test Methods for Pore Size Characteristics of Membrane Filters by Bubble Point and Mean Flow Pore Test<sup>1</sup>

This standard is issued under the fixed designation F316; the number immediately following the designation indicates the year of original adoption or, in the case of revision, the year of last revision. A number in parentheses indicates the year of last reapproval. A superscript epsilon ( $\epsilon$ ) indicates an editorial change since the last revision or reapproval.

## 1. Scope

1.1 These test methods cover the determination of two of the pore size properties of membrane filters with maximum pore sizes from 0.1 to 15.0  $\mu\text{m}$ .

1.2 Test Method A presents a test method for measuring the maximum limiting pore diameter of nonfibrous membranes. The limiting diameter is the diameter of a circle having the same area as the smallest section of a given pore (Fig. 1).

1.3 Test Method B measures the relative abundance of a specified pore size in a membrane, defined in terms of the limiting diameter.

1.4 The analyst should be aware that adequate collaborative data for bias statements as required by Practice D2777 is not provided. See the precision and bias section for details.

1.5 The values stated in SI units are to be regarded as standard. No other units of measurement are included in this standard.

1.6 *This standard may involve hazardous materials, operations, and equipment. This standard does not purport to address all of the safety concerns, if any, associated with its use. It is the responsibility of the user of this standard to establish appropriate safety and health practices and determine the applicability of regulatory limitations prior to use.*

## 2. Referenced Documents

2.1 *ASTM Standards:*<sup>2</sup>

D1129 Terminology Relating to Water

D1193 Specification for Reagent Water

D2777 Practice for Determination of Precision and Bias of Applicable Test Methods of Committee D19 on Water

E128 Test Method for Maximum Pore Diameter and Perme-

ability of Rigid Porous Filters for Laboratory Use

## 3. Terminology

3.1 *Definitions*—For definitions of other terms used in these test methods, refer to Terminology D1129.

3.2 *Definitions of Terms Specific to This Standard:*

3.2.1 *pore size*—capillary equivalent pore diameter.

3.2.2 *limiting pore diameter*—diameter of a circle having the same area as the smallest section of a given pore.

## TEST METHOD A—MAXIMUM PORE SIZE

### 4. Summary of Test Method

4.1 The bubble point test for maximum pore size is performed by prewetting the filter, increasing the pressure of gas upstream of the filter at a predetermined rate and watching for gas bubbles downstream to indicate the passage of gas through the maximum diameter filter pores.

4.2 The pressure required to blow the first continuous bubbles detectable by their rise through a layer of liquid covering the filter is called the "bubble point", and is used to calculate maximum pore size.

### 5. Significance and Use

5.1 This test method may be used to:

5.1.1 Determine the maximum pore size of a filter,

5.1.2 Compare the maximum pore sizes of several filters, and

5.1.3 Determine the effect of various processes such as filtration, coating, or autoclaving on the maximum pore size of a membrane.

5.2 Membrane filters have discrete pores from one side to the other of the membrane, similar to capillary, tubes. The bubble point test is based on the principle that a wetting liquid is held in these capillary pores by capillary attraction and surface tension, and the minimum pressure required to force liquid from these pores is a function of pore diameter. The pressure at which a steady stream of bubbles appears in this test is the bubble point pressure. The bubble point test is significant

<sup>1</sup> These test methods are under the jurisdiction of ASTM Committee D19 on Water and are the direct responsibility of Subcommittee D19.08 on Membranes and Ion Exchange Materials.

Current edition approved May 1, 2011. Published June 2011. Originally approved in 1970 as F316–70. Last previous edition approved in 2003 as F316–03. DOI: 10.1520/F0316-03R11.

<sup>2</sup> For referenced ASTM standards, visit the ASTM website, www.astm.org, or contact ASTM Customer Service at service@astm.org. For *Annual Book of ASTM Standards* volume information, refer to the standard's Document Summary page on the ASTM website.

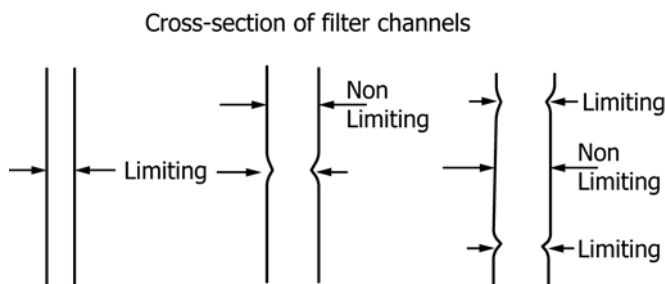

FIG. 1 Examples of Limiting Diameters

not only for indicating maximum pore size, but may also indicate a damaged membrane, ineffective seals, or a system leak.

5.3 The results of this test method should not be used as the sole factor to describe the limiting size for retention of particulate contaminants from fluids. The effective pore size calculated from this test method is based on the premise of capillary pores having circular cross sections, and does not refer to actual particle size retention. See Test Method E128 for additional information.

## 6. Apparatus

6.1 *Filter Holder*, as shown in Fig. 2, consisting of a base A, a locking ring B, O-ring seal C, support disk D, and gas inlet E. The support disk shall be 2-ply construction, consisting of a 100 by 100 mesh or finer screen and a perforated metal plate for rigidity. The diameter of the test filter may be either 25 or 47 mm, as appropriate to the holder being used for the test.

6.2 *Manifold*, as shown in Fig. 3, a micrometric flow control valve capable of providing a linear rise in pressure and a gas ballast of at least 16 000-cm<sup>3</sup> capacity.

NOTE 1—For less accurate determinations, the simplified apparatus shown in Fig. 4 may be used.

6.3 *Pressure Gages* (and mercury manometer if required), covering the range of pressures needed for the pore sizes under investigation (see Table 1).

6.4 *Metal Punch*, used to cut a suitable size filter from the test sheet to fit the test filter holder.

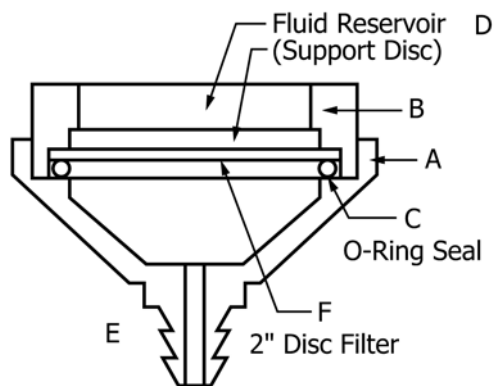

FIG. 2 Filter Holder

## 7. Reagents

7.1 *Purity of Reagents*—Reagent grade chemicals shall be used in all tests. Unless otherwise indicated, it is intended that all reagents shall conform to the specifications of the Committee on Analytical Reagents of the American Chemical Society where such specifications are available.<sup>3</sup> Other grades may be used provided it is first ascertained that the reagent is of sufficient high purity to permit its use without lessening the accuracy of the determination.

7.2 *Water*, conforming to Specification D1193, Type IV or higher purity.

7.3 *Denatured Alcohol*.

7.4 *Petroleum Distillate*, with surface tension of 30 dynes/cm at 25°C.

7.5 *Mineral Oil*, such as USP liquid petrolatum heavy, with surface tension of 34.7 dynes/cm at 25°C.

7.6 *1,1,2-trichloro-1,2,2-trifluoroethane (Freon TF®)*, available from commercial chemical supply houses.

7.7 *Clean Gas Pressure Source*, with regulation (filtered air or nitrogen).

NOTE 2—Table 1 lists the nominal surface tension of these liquids at 25°C. Table 2 lists the simplified maximum pore size formulas based on these values, where the liquid completely wets the membrane.

## 8. Procedure

8.1 Wet the test membrane completely by floating it on a pool of the liquid. Use a vacuum chamber to assist in wetting the filter, if needed.

8.2 Place the wet membrane in the filter holder.

8.3 Close the filter holder and apply slight gas pressure to eliminate possible liquid back flow.

8.4 Cover the perforated metal plate with 2 to 3 mm of test liquid.

8.5 Increase the gas pressure slowly. Record the lowest pressure at which a steady stream of bubbles rises from the central area of the liquid reservoir.

NOTE 3—Faulty sealing may cause erroneous bubbling from the sealing edge of the liquid reservoir. Be sure to record the bubble point pressure with bubbles from the central area of the reservoir (see Fig. 5).

## 9. Calculation

9.1 If the test liquid is known to wet the membrane completely, calculate the maximum pore size from the following equation:

$$d = C\gamma/p \quad (1)$$

<sup>3</sup> *Reagent Chemicals, American Chemical Society Specifications*, American Chemical Society, Washington, DC. For Suggestions on the testing of reagents not listed by the American Chemical Society, see *Annual Standards for Laboratory Chemicals*, BDH Ltd., Poole, Dorset, U.K., and the *United States Pharmacopeia and National Formulary*, U.S. Pharmacopeial Convention, Inc. (USPC), Rockville, MD.

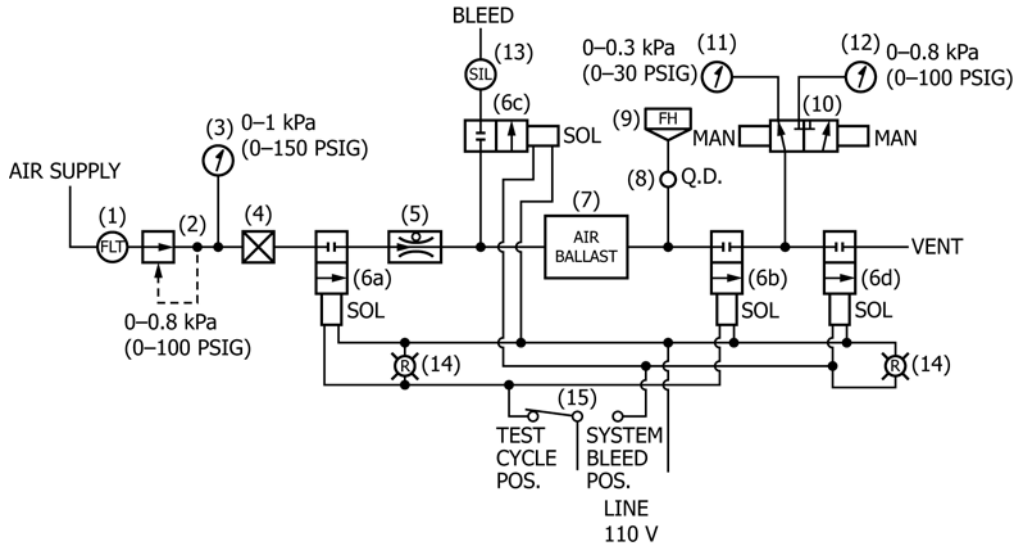

Key	Quantity	Component
1	1	Filter
2	1	Pressure regulator
3	1	Pressure gage
4	1	Valve shutoff, manual
5	1	Valve, flow control, manual
6	4	Valve, solenoid, nc
7	1	Air ballast
8	1	Quick disconnect fitting
9	2	Open filter holder, 47 mm
10	1	Valve, 3-way, manual
11	1	Test gage, 0-0.3 kPa (0-30 psig)
12	1	Test gage, 0-0.8 kPa (0-100 psig)
13	1	Exhaust silencer
14	2	Pilot light, red, elec.
15	1	Switch, spdt, elec.

FIG. 3 Manifold for Bubble Point Testing

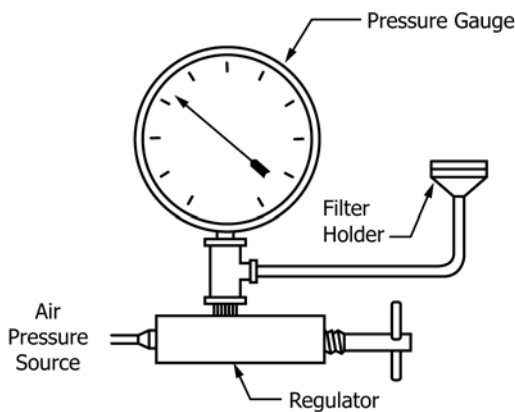

FIG. 4 Test Setup (Simplified)

where:

- $d$  = limiting diameter,  $\mu\text{m}$ ,
- $\gamma$  = surface tension,  $\text{mN/m}$ , ( $\text{dynes/cm}$ ),
- $p$  = pressure, Pa or cm Hg, and
- $C$  = constant, 2860 when  $p$  is in Pa, 2.15 when  $p$  is in cm Hg, and 0.415 when  $p$  is in psi units.

NOTE 4—The fluid must completely wet the membrane filter with the contact angle being zero. If the contact angle is greater than zero, the

calculated effective pore size will be larger than the actual effective pore size rating.

## 10. Reporting Results

10.1 Record the minimum pressure for gas passage as indicated by continuous bubbles. Record the maximum pore size calculated, along with identification of the membrane tested and the liquid used.

## TEST METHOD B—DETERMINATION OF PORE SIZE DISTRIBUTION

### 11. Summary of Test Method

11.1 A fluid-wet filter will pass air when the applied air pressure exceeds the capillary attraction of the fluid in the pores. Smaller pores will exhibit similar behavior at higher pressures. The relationship between pore size and pressure has been established, as indicated in Table 2.

11.2 By comparing the gas flow rates of both a wet and dry filter at the same pressures, the percentage of the flow passing through the filter pores larger than or equal to the specified size may be calculated from the pressure-size relationship. By

TABLE 1 Pressure Ranges Required

Fluid Used	Pore Size Range to be Investigated (Alternative psi)				Surface Tension, dynes/cm at 25°C
	≥1 μm	≥0.5 μm	≥0.1 μm	≥0.05 μm	
Water	0 to 155 cm Hg (0 to 30 psi)	0 to 310 cm Hg (0 to 60 psi)	0 to 775 cm Hg (0 to 150 psi)	0 to 3100 cm Hg (0 to 600 psi)	72.0
Petroleum distillate	0 to 65 cm Hg (0 to 15 psi)	0 to 130 cm Hg (0 to 25 psi)	0 to 325 cm Hg (0 to 65 psi)	0 to 1300 cm Hg (0 to 250 psi)	30.0
Denatured alcohol	0 to 50 cm Hg (0 to 10 psi)	0 to 100 cm Hg (0 to 20 psi)	0 to 250 cm Hg (0 to 50 psi)	0 to 1000 cm Hg (0 to 200 psi)	22.3
Mineral oil	0 to 75 cm Hg (0 to 15 psi)	0 to 150 cm Hg (0 to 30 psi)	0 to 305 cm Hg (0 to 75 psi)	0 to 1500 cm Hg (0 to 300 psi)	34.7
Freon TF®	0 to 40 cm Hg (0 to 8 psi)	0 to 80 cm Hg (0 to 16 psi)	0 to 200 cm Hg (0 to 40 psi)	0 to 800 cm Hg (0 to 100 psi)	17.3

TABLE 2 Calculation of Maximum Pore Size from Bubble Point Pressure,<sup>A</sup>  $d = C/P$

NOTE 1—Refer to Appendix X1 for derivation of maximum pore size formula.

Fluid Used	Pressure Units of Bubble Point		
	cm Hg	psi	Pa
Water	155/Bubble Point	30.0/Bubble Point	$2.06 \times 10^5$ /Bubble Point
Petroleum distillate	64.6/Bubble Point	12.5/Bubble Point	$8.58 \times 10^4$ /Bubble Point
Denatured alcohol	47.75/Bubble Point	9.25/Bubble Point	$6.38 \times 10^4$ /Bubble Point
Mineral oil	74.5/Bubble Point	14.4/Bubble Point	$9.92 \times 10^4$ /Bubble Point
Freon TF®	37.2/Bubble Point	7.2/Bubble Point	$4.95 \times 10^4$ /Bubble Point

<sup>A</sup> Example—A certain filter was observed to have a bubble point of 41.0 psi with petroleum distillate:

Size (μm) = 12.5/41.0 psi  
Therefore, maximum pore size = 0.305 μm.

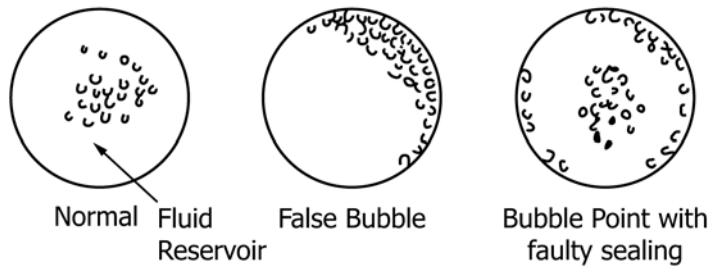

FIG. 5 Examples of Erroneous Bubble Points

increasing pressure in small steps, it is possible to determine the flow contribution of very small pore size increments by difference.

11.3 To determine the mean flow pore size, a pressure is sought at which the wet filter flow is one half of the dry filter flow.

## 12. Significance and Use

12.1 This test method may be used to:

12.1.1 Determine the pore size distribution of a membrane filter,

12.1.2 Determine the mean flow pore size of a membrane filter,

12.1.3 Determine the effect of processes such as sterilization, upon the pore size distribution,

12.1.4 Measure the maximum pore size of a membrane filter, and

12.1.5 Determine the gas flow rate of a filter, and thereby its gas flow capability.

## 13. Apparatus

13.1 *Clean Gas Pressure Source*, with regulation (filtered air or nitrogen).

13.2 *Pressure Gage* (or set of gages), covering the necessary pressure range for the pore sizes under study. (See Table 1.)

13.3 *Closed Filter Holder*, (see Fig. 6).

NOTE 5—Two 1-in. (25-mm) filter holders, instead of one holder, eliminate the task of cleaning the filter holder after a fluid-wet air flow determination. A two-position gas valve to switch the gas pressure from dry to wet holders may be used (see Fig. 7).

13.4 *Set of Rotameters*, covering the range from 0 to 100 L/min.

13.5 *Test Tube and Capillary Tube*, to serve for detection of the bubble point.

13.6 *In-Line Fluid Trap*, to protect the rotameters from the fluid.

13.7 *Appropriate Fittings, Hose, Connectors, Piping*, to assemble apparatus as shown in Figs. 6 and 7.

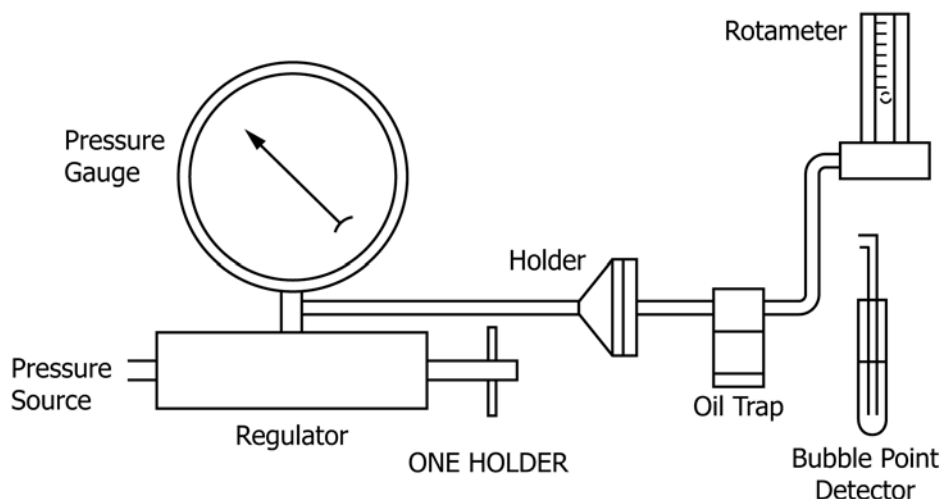

FIG. 6 Setup for One Holder

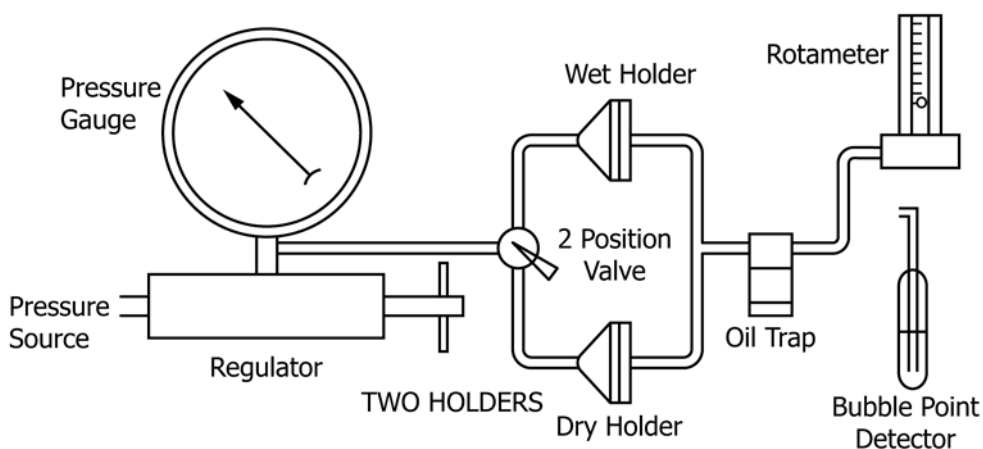

FIG. 7 Setup for Two Holders

13.8 *x-y Recorder*, to assist in graphing results of mean flow pore test.

#### 14. Reagents

14.1 *Mineral Oil*, such as USP liquid petrolatum heavy.

#### 15. Procedure for One Holder (Fig. 6)

15.1 Place a dry filter sample disk in the filter holder.

15.2 Close the holder and apply gas pressure in increments.

15.3 Plot gas flow versus gas pressure over the intended range of use. (Estimate from pore size-pressure formula, see Table 1.)

15.4 Reduce gas pressure and remove the filter from the holder.

15.5 Completely wet the filter in mineral oil, replace the wet filter in the holder, and apply a slight pressure, checking to see that a tight seal exists.

15.6 Increase pressure gradually and record the pressure of the first gas flow detected by the capillary tube tip immersed in the test tube half-filled with mineral oil.

15.7 Change to rotameters and plot the fluid-wet filter gas flow versus pressure on the same coordinates as for the plot made in accordance with 15.3.

15.8 Reduce the pressure, remove the filter, and clean the holder for the next test.

#### 16. Procedure for Two Holders (Fig. 7)

16.1 Place a dry filter in the holder to be used exclusively for dry filters.

16.2 Wet a filter of the same type and lot as the filter used in 16.1, in mineral oil and place it in a holder to be used exclusively for wet filters.

16.3 Apply gas pressure to the dry filter and plot gas flow versus gas pressure.

16.4 Change the two position valve to apply gas pressure to the wet filter holder and record the first gas flow as detected by the capillary tube as the bubble point. Switch to rotameters and plot fluid-wet gas flow versus gas pressure.

**17. Calculation of Mean Flow Pore Size**

17.1 Record the minimum pressure for gas passage (bubble point pressure). Calculate the maximum pore size from the formula in 9.1 and correlation data in Table 2.

17.2 Using the graph from 16.3, draw the line (or curve) corresponding to one half the dry gas-flow rate of the tested filter. Find the intersection of this (one-half dry-flow) line and the wet flow line (or curve), as shown in Fig. 8. Determine the pressure coordinate of the intersection and substitute into the pressure-pore size formula. (See Table 2 for mineral oil.)

**18. Calculation of Pore Size Frequency**

18.1 Select the limits of the pore size range being evaluated. Substitute the limits individually into the pore-size versus pressure formula and obtain their respective pressures. From the test graph, determine the wet and dry flows at the pressure limits (pore size limits of the range) as shown in Fig. 9.

18.2 Substitute the values found in the following equation:

$$Q = \left[ \left( \frac{\text{wet flow}_h}{\text{dry flow}_h} \right) - \left( \frac{\text{wet flow}_l}{\text{dry flow}_l} \right) \right] \times 100 \quad (2)$$

where:

- Q = filter flow, %,
- l = lower pressure limit, and
- h = higher pressure limit.

18.3 Report Q as the percentage of the filter flow passing through pores within the range specified.

NOTE 6—Example—Determine the percentage of the filter flow passing through a pore size range from 0.8 to 0.2 μm of the filter described in Fig. 9.

$$Q = \left[ \left( \frac{7 \text{ L/min}}{21 \text{ L/min}} \right) - \left( \frac{2 \text{ L/min}}{15 \text{ L/min}} \right) \right] \times 100 \quad (3)$$

$$= [0.333 - 0.133] \times 100$$

$$= 20 \%$$

Twenty percent of the gas passing through the filter described in Fig. 9 moves through pores between 0.8 and 0.2 μm.

**19. Precision and Bias**

19.1 Results should not differ from the mean by more than the following amounts:

Pore Size Range	Repeatability, % Same Operator and Apparatus	Reproducibility, % Different Operator and Apparatus
Greater than 1 μm	2	4
1 to 0.5 μm	1	2.5
Less than 0.5 μm	0.5	1

19.2 Since the change in pore size per unit change in applied pressure is greatest at large pore sizes and diminishes hyperbolically, repeatability and reproducibility increase accordingly with applied pressure.

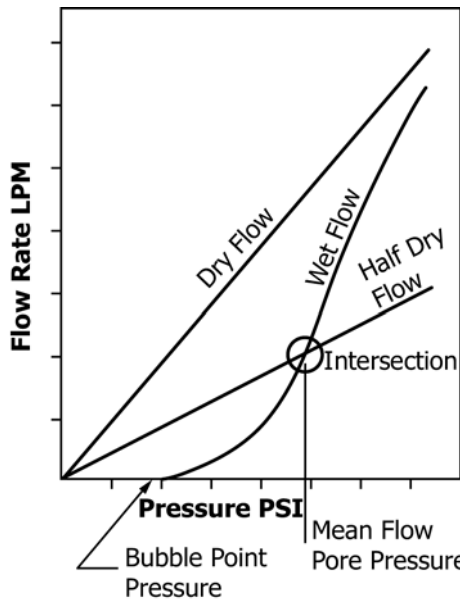

FIG. 8 Example of Mean Flow Pore Determination

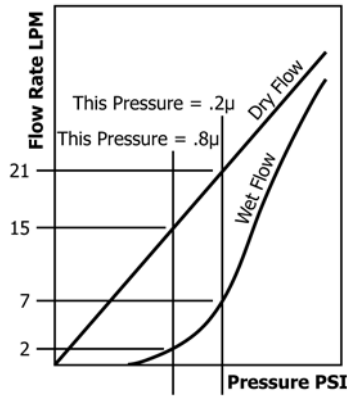

FIG. 9 Example of Pore Size Frequency Determination  
 FIG. 9 Example of Pore Size Frequency Determination

APPENDIX

(Nonmandatory Information)

X1. PORE SIZE FORMULA DERIVATION

X1.1 The pore size formula is derived as follows:

Surface tension formula:

$$\gamma = hpgr / (2 \cos \phi B) \tag{X1.1}$$

Rearranging for diameter (2r):

$$d = (4 \cos \phi B \gamma) / hp \tag{X1.2}$$

At bubble point pressure  $P = hgp$ :

$$d = (4 \cos \phi B \gamma) / P \tag{X1.3}$$

When a fluid wets a filter  $\cos \phi = 1$ :

$$d = 4B\gamma / P \tag{X1.4}$$

where:

- $h$  = height of rise,
- $p$  = density of fluid,

- $g$  = gravitational constant,
- $r$  = radius of tube,
- $\phi$  = contact angle,
- $B$  = capillary constant, and
- $\gamma$  = surface tension.

Substituting pressure conversion factors and the capillary constant:

For centimetres of Hg:

$$d = [2.145 \gamma \text{ (dynes/cm)}] / [P \text{ (cm Hg)}] \tag{X1.5}$$

For psi:

$$d = [0.415 \gamma \text{ (dynes/cm)}] / [P \text{ (psi)}] \tag{X1.6}$$

For Pa:

$$d = [2860 \gamma \text{ (dynes/cm)}] / [P \text{ (Pa)}] \tag{X1.7}$$

*ASTM International takes no position respecting the validity of any patent rights asserted in connection with any item mentioned in this standard. Users of this standard are expressly advised that determination of the validity of any such patent rights, and the risk of infringement of such rights, are entirely their own responsibility.*

*This standard is subject to revision at any time by the responsible technical committee and must be reviewed every five years and if not revised, either reapproved or withdrawn. Your comments are invited either for revision of this standard or for additional standards and should be addressed to ASTM International Headquarters. Your comments will receive careful consideration at a meeting of the responsible technical committee, which you may attend. If you feel that your comments have not received a fair hearing you should make your views known to the ASTM Committee on Standards, at the address shown below.*

*This standard is copyrighted by ASTM International, 100 Barr Harbor Drive, PO Box C700, West Conshohocken, PA 19428-2959, United States. Individual reprints (single or multiple copies) of this standard may be obtained by contacting ASTM at the above address or at 610-832-9585 (phone), 610-832-9555 (fax), or service@astm.org (e-mail); or through the ASTM website (www.astm.org). Permission rights to photocopy the standard may also be secured from the Copyright Clearance Center, 222 Rosewood Drive, Danvers, MA 01923, Tel: (978) 646-2600; http://www.copyright.com/*