



# Standard Specification for Unsupervised Public Use Outdoor Fitness Equipment<sup>1</sup>

This standard is issued under the fixed designation F3101; the number immediately following the designation indicates the year of original adoption or, in the case of revision, the year of last revision. A number in parentheses indicates the year of last reapproval. A superscript epsilon ( $\epsilon$ ) indicates an editorial change since the last revision or reapproval.

## INTRODUCTION

The goal of this specification is to promote proper design, manufacturing, installation, and operational practices for unsupervised outdoor fitness equipment for use in parks, schools, institutions, multiple-family dwellings, private resorts, recreation developments and other areas. These products are intended to be used by individuals age 13 and older and typically are used in an unsupervised setting. Through these specifications, this specification aims to assist designers, manufactures, and owner/operators in reducing the possibility of injury.

Adult anthropometrics are used in the design of this equipment. The equipment specifications set forth in this standard are for equipment intended for use by individuals 13 and older. Adults must take precautions and prevent children under their supervision from accessing and using this equipment. This standard specifies requirements that are generally applicable to all outdoor fitness equipment used in an unsupervised setting.

The equipment user must recognize, however, that a standard alone will not necessarily prevent injuries. Like other physical activities, exercise involving outdoor fitness equipment, involves the risk of injury, particularly if the equipment is used improperly, not properly installed or not properly maintained. In addition, users with physical limitations should be aware of their capabilities and limitations in the use of this type of equipment and seek appropriate advice prior to using it. Certain physical conditions or limitations may preclude some persons from using this equipment properly and without increasing the risk of serious injury. While the designer, manufacturer, and owner cannot control the public use of this unsupervised equipment they can address known causes of injuries to the most vulnerable users and unintended users-at-risk defined as those under the age of 13. Good design and best practice would dictate that these facilities are not in physical proximity or physically separated from playground for children because of hazardous conditions children cannot appreciate.

## 1. Scope

1.1 This specification establishes parameters for the design and manufacture of outdoor fitness equipment as defined in 3.1.30.

1.2 It is intended that these fitness products will be used in an unsupervised outdoor setting or environment and will be permanently anchored.

1.2.1 It is the intent of this specification to only specify requirements for outdoor fitness equipment and its installation and not the design of the facility or grounds on which the products are to be installed.

<sup>1</sup> This specification is under the jurisdiction of ASTM Committee F08 on Sports Equipment, Playing Surfaces, and Facilities and is the direct responsibility of Subcommittee F08.30 on Fitness Products.

Current edition approved April 1, 2015. Published May 2015. DOI: 10.1520/F3101-15.

1.3 The specifications set forth in this standard are intended to minimize the likelihood of serious injuries.

1.3.1 The specifications set forth in this standard are for outdoor fitness equipment intended for use in an unsupervised setting by individuals age 13 and older.

1.4 The values stated in SI (metric) units are to be regarded as standard. The values in parentheses are for information only.

### 1.5 General Measures, Tolerances, and Conversions:

1.5.1 The general tolerances for this specification (unless otherwise specified) are as follows:

Dimension	Tolerance
X mm (X in.)	± 13.0 mm (0.5 in.)
X.X mm (X.X in.)	± 1.3 mm (0.05 in.)
X.XX mm (X.XX in.)	± 0.130 mm (0.005 in.)

1.5.2 These tolerances still apply to a dimension even when terms like greater than, less than, minimum, or maximum are used.

1.6 This standard is to be used in conjunction with Test Methods **F2571** and Specification **F2276**. If a design or installation concern is not addressed in this specification then the applicable requirements of Specification **F2276** shall be used.

1.6.1 This standard takes precedence over Specification **F2276** and Test Methods **F2571** in areas that are addressed in this document.

1.7 *This standard does not purport to address all of the safety concerns, if any, associated with its use. It is the responsibility of the user of this standard to establish appropriate safety and health practices and determine the applicability of regulatory limitations prior to use.*

## 2. Referenced Documents

### 2.1 ASTM Standards:<sup>2</sup>

**F1077** Guide for Selection of Committee F16 Fastener Specifications (Withdrawn 2014)<sup>3</sup>

**F1292** Specification for Impact Attenuation of Surfacing Materials Within the Use Zone of Playground Equipment

**F1749** Specification for Fitness Equipment and Fitness Facility Safety Signage and Labels

**F1951** Specification for Determination of Accessibility of Surface Systems Under and Around Playground Equipment

**F2276** Specification for Fitness Equipment

**F2571** Test Methods for Evaluating Design and Performance Characteristics of Fitness Equipment

**F3021** Specification for Universal Design of Fitness Equipment for Inclusive Use by Persons with Functional Limitations and Impairments

**F3022** Test Method for Evaluating the Universal Design of Fitness Equipment for Inclusive Use by Persons with Functional Limitations and Impairments

### 2.2 ANSI Standards:<sup>4</sup>

**ANSI Z535.1** Safety Color Code

**ANSI Z535.2** Environmental and Facility Safety Signs

**ANSI Z535.4** Products Safety—Signs and Labels

**ANSI Z535.6** Product Safety Information in Product Manuals, Instructions, and Other Collateral Materials

### 2.3 Federal Standards:<sup>5</sup>

NOTE 1—The following standard is a United States federal standard that may not be applicable in other countries.

**DOJ 2010 Standard for Accessible Design United States Department of Justice (DOJ) 2010 Standard for Accessible Design: Title II (28 CFR 35) and Title III (28 CFR 36)**<sup>6</sup>

<sup>2</sup> For referenced ASTM standards, visit the ASTM website, [www.astm.org](http://www.astm.org), or contact ASTM Customer Service at [service@astm.org](mailto:service@astm.org). For *Annual Book of ASTM Standards* volume information, refer to the standard's Document Summary page on the ASTM website.

<sup>3</sup> The last approved version of this historical standard is referenced on [www.astm.org](http://www.astm.org).

<sup>4</sup> Available from American National Standards Institute (ANSI), 25 W. 43rd St., 4th Floor, New York, NY 10036, <http://www.ansi.org>.

<sup>5</sup> Available from U.S. Government Printing Office Superintendent of Documents, 732 N. Capitol St., NW, Mail Stop: SDE, Washington, DC 20401, <http://www.access.gpo.gov>.

<sup>6</sup> Available free at: <http://www.ada.gov/reg2010/ADAregs2010.htm>.

### 2.4 UL Standard:<sup>7</sup>

**UL 969** Standard for Safety: Marking and Labeling Systems

## 3. Terminology

### 3.1 Definitions of Terms Specific to This Standard:

3.1.1 *accessible area, n*—area accessible to the user or third party when the equipment is used as intended, grasped, or adjusted.

3.1.1.1 *Discussion*—This area encompasses a region from the floor to a height of 2134 mm (84 in.) above the underlying surface. This does not include areas that are accessible during the initial assembly.

3.1.2 *accessible, adj*—relating to a part or portion of the outdoor fitness equipment that (1) can be contacted by any body part or (2) is approachable or usable, or both, by persons of varying abilities.

3.1.3 *accessible route, n*—pathway specifically intended to provide access for individuals with disabilities.

3.1.4 *applied handgrips, n*—handgrips that are formed, molded, or attached to a support, component, or structure.

3.1.5 *clearance space, n*—area beneath and immediately adjacent to outdoor fitness equipment that is designated for unrestricted circulation around the equipment and on whose surface it is predicted that a user would land when falling from or exiting the equipment.

3.1.6 *completely bounded opening, n*—any opening in a piece of equipment that is totally enclosed by boundaries on all sides such that the perimeter of the opening is continuous.

3.1.7 *component, n*—any portion of a structure that generates specific activity and cannot stand alone.

3.1.8 *composite fitness structure, n*—two or more fitness structures attached or functionally linked, to create one integral unit that provides more than one fitness activity; an example is a combination horizontal ladder, chinning bar, vertical lunge, and balance beam.

3.1.9 *corner, n*—intersection of three planes or surfaces on a single component.

3.1.10 *crush point, n*—location between two moving components that when entered can cause a portion of the body to suffer a contusion, laceration, abrasion, amputation, or fracture.

3.1.11 *cycle, n*—movement of a point or load away from a starting position and back to the same starting position. The cycle being executed through the full range of intended motion.

3.1.12 *designated use surface, n*—any elevated surface intended for gripping/hanging, standing, walking, sitting, or climbing.

3.1.13 *edge, n*—intersection of two planes or surfaces on a single component.

3.1.14 *engagement means, n*—the portion of the outdoor fitness equipment that is moved by the user to perform the intended exercise as defined by the manufacturer.

<sup>7</sup> Available from Underwriters Laboratories (UL), 2600 N.W. Lake Rd., Camas, WA 98607-8542, <http://www.ul.com>.

3.1.15 *entanglement, n*—condition in which an article on the user such as clothing, hair or something around the user’s neck becomes caught or entwined on a component of outdoor fitness equipment.

3.1.16 *entrapment, n*—condition which impedes withdrawal of a body or body part that has penetrated an opening.

3.1.17 *extrinsic loads, n*—all loads applied to the machine or engagement means in addition to the users body weight.

3.1.18 *fall height, n*—vertical distance between a designated use surface and the protective surfacing beneath it.

3.1.19 *foot support, n*—portion of the outdoor fitness equipment intended to support all or a portion of the user’s body weight or exertion during the performance of the intended exercise as defined by the manufacturer. May be a “step”, “stair” or “rung” as defined in this section.

3.1.20 *functional training grip, n*—typically a free form shape designed to be gripped for climbing and hanging exercises. Also referred to as rock climbing grips typically found on climbing walls or structures.

3.1.21 *general warning label, n*—label designed within the scope of this specification and Specification **F1749** which is affixed to a portion of the fitness equipment and draws attention to potential hazards associated with the use of that equipment.

3.1.22 *grasp, v*—to hold by hand, may be done to support one’s self for balance or guidance; hands fit around only a portion of the circumference of the object.

3.1.23 *grip, v*—to hold by hand tightly so one does not slip or fall or so that one can execute force to initiate or control movement of the apparatus; hands fit around a majority of the circumference of the object.

3.1.24 *guard, n*—cover or enclosure that limits access to an otherwise accessible area.

3.1.25 *integral handgrips, n*—handgrips that are created by, coating, texturing or otherwise modifying the material of a component or support structure.

3.1.26 *intended use, n*—the use of the outdoor fitness equipment as described in the manual or on the signage provided with it and/or as is readily apparent from its use as fitness equipment.

3.1.27 *intrinsic loads, n*—the loads applied to fitness equipment due only to the user’s body weight.

3.1.28 *maximum specified load, n*—maximum working load for the machine as set by the manufacturer.

3.1.29 *maximum tension developed, n*—maximum static tensile load experienced by a connector, fitting, rope, belt, chain, or other component during use of the machine at the maximum specified load for the machine including all extrinsic loads.

3.1.30 *outdoor fitness equipment, n*—an anchored structure or mechanical apparatus intended for unsupervised outdoor public use on which the user trains or exercises specific or multiple muscles of the body.

3.1.30.1 *Discussion*—Not to include toys used for recreation, jump ropes, outdoor playground equipment or

facilities, military facilities or equipment designed for military training, bicycles or other fitness soft goods such as gloves, belts, apparel, balls, and so forth. Independent loose items intended to be manipulated by the intended users are not covered in this standard.

3.1.31 *owner’s manual, n*—documentation supplied and intended by the manufacturer to convey information, including safety features and warnings, to the owner about the equipment, its installation, inspection, maintenance, and repair.

3.1.32 *partially bounded opening, n*—any opening in a piece of equipment that is not totally enclosed by boundaries on all sides so that the perimeter of the opening is discontinuous.

3.1.33 *platform, n*—flat surface, intended for the user(s) to stand, and upon which the user(s) can move freely.

3.1.34 *professional judgment, n*—ability of an individual with current knowledge, skill or experience, or both, in the field of outdoor fitness equipment design, use, or operations, which enables that person to form an opinion or make a decision, or both, concerning a matter within that field of expertise.

3.1.35 *projection, n*—condition which, due to its physical nature, must be tested to the requirements of this standard to determine whether it is a protrusion and/or entanglement hazard.

3.1.36 *protective surfacing, n*—material(s), if required, to be used within the clearance space of the outdoor fitness equipment in accordance with Specifications **F1292** and **F1951** where applicable.

3.1.37 *protrusion, n*—projection which, when tested in accordance with the requirements of this standard is found to be a hazard having the potential to cause bodily injury to a user who impacts it.

3.1.38 *range of movement, operator, n*—space in which the user or part of the user is moving when using the machine as recommended by the manufacturer.

3.1.39 *range of movement, equipment, n*—space in which the equipment component(s) can move or be moved during the operation of the equipment.

3.1.40 *resistance means, n*—the device or system that provides a resistive force to the user during exercise. This system may or may not be adjustable where the user can vary the device or system to increase or decrease the force encountered.

3.1.41 *rung, n*—cross piece in a ladder or other climbing equipment used for supporting the user’s feet or for grasping by the user’s hands and/or both.

3.1.42 *serious injury, n*—an acute physical injury requiring medical treatment in a hospital or clinic under the supervision of a qualified doctor or nurse; examples of such injuries includes burns, fractures, lacerations, internal injury, injury to organs, concussion, internal bleeding, etc.

3.1.43 *sharp edge, n*—edge that can cut a user’s skin.

3.1.44 *sharp point/corner, n*—point or corner that can puncture or lacerate a user’s skin.

3.1.45 *shear point, n*—location at which parts move past one another or past a fixed point in such a manner that, when entered, can cause a portion of the body to become seriously injured in a scissors action between the components.

3.1.46 *site specific label, n*—label designed within the scope of this specification and Specification F1749 which is affixed to a portion of the equipment and draws attention to a potential hazard in the immediate area of the label.

3.1.47 *step, n*—horizontal flat surface of a ladder or stair used primarily as a foot support.

3.1.48 *third party, n*—someone other than the user who is in the immediate area of the fitness equipment when it is in use.

3.1.49 *training envelope, n*—maximum space in which the user and machine components traverse when the machine is operated in accordance with the instructions. (see also operator range of movement and equipment range of movement). Synonymous with “use zone”.

3.1.50 *trip hazard, n*—abrupt change in elevation that may not be clear and obvious to the user.

3.1.51 *upper body fitness equipment, n*—fitness equipment intended to exercise the upper body (torso and arms). For the purposes of this standard this may also encompass overhead components intended to support a user by the hands only (for example, horizontal ladders, chinning bars, and ring ladders).

3.1.52 *user weight (maximum), n*—manufacturer defined weight of the exerciser that the equipment was designed to accommodate.

3.1.53 *user support, n*—a surface or structure that supports a portion or all of the user’s body weight while performing the intended exercise as defined by the manufacturer.

**4. Requirements for Access/Egress**

4.1 Accessibility of outdoor fitness equipment installed in the United States and its territories shall meet the following accessibility requirements.

4.2 Accessible Routes to and around outdoor fitness equipment shall meet the parameters established in the DOJ 2010 Standard for Accessible Design.

4.2.1 Accessible routes within the clearance space shall conform to the performance requirements of Specifications F1292 and F1951.

4.3 Access to outdoor fitness equipment machines or structures shall meet the parameters established in the DOJ 2010 Standard for Accessible Design.

4.4 Spacing between individual pieces of outdoor fitness equipment or structures shall meet the parameters established in the DOJ 2010 Standard for Accessible Design and Section 9 of this specification.

**5. Equipment Types**

5.1 *General Descriptions*—Outdoor fitness equipment varies and all designs may not be represented specifically in each of the following sections. The following sections are intended to group the most prevalent equipment as well as accommodate future designs.

5.2 *Fixed Apparatus*—Equipment with non-moving parts, such as bars, beams, overhead equipment, benches, racks, step platforms and climbing structures. Equipment support posts with no designated use surfaces have no fall height requirements.

5.2.1 *Balance Beams, Jump Bars, Push-up Bars*—These pieces are installed at low heights and used to stand on, walk on, jump over, and push off of.

5.2.2 *Overhead Equipment*—This type of equipment may have various forms that have relatively high or overhead installed heights and are used to hang from, or perform other upper body exercises.

5.2.3 *Racks/Benches*—This equipment is intended for sitting on, lying on, or performing exercises at mid-level heights greater than 406 mm (16.0 in.) and less than 1219 mm (48.0 in.) from the installation surface. They include sit-up benches, parallel bars, and similar products.

5.3 *Resistance Apparatus*—Equipment designed/intended for strength/resistance training that lifts the user or provides resistive loads that must be overcome to move the engagement means.

5.3.1 For equipment that lifts the user, handles or other end effectors are connected by joints and linkages to a seat or platform on which a user rests; when operated, the user is lifted to generate resistance against movement of the end effector. Examples include chest presses, lat pulls, leg presses.

5.4 *Swinging Apparatus*—Equipment with moving parts intended for motion simulation exercise that may or may not

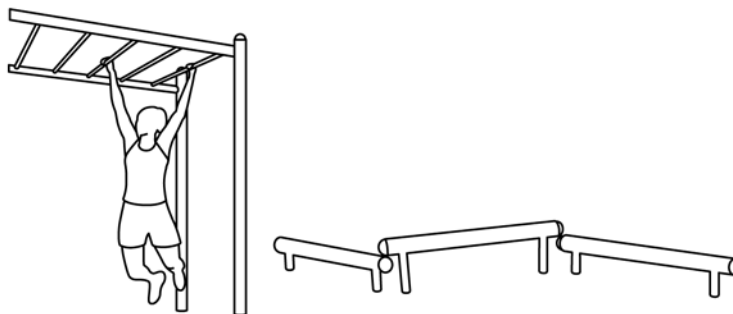

FIG. 1 Fixed Apparatus



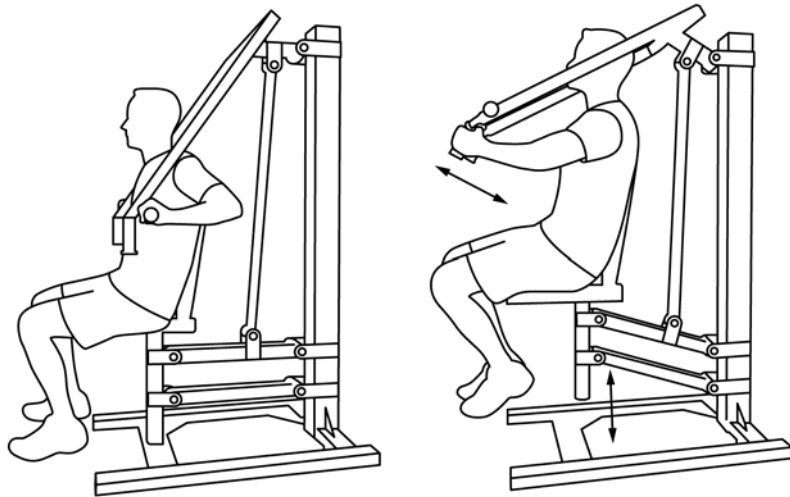

FIG. 2 Resistance Apparatus

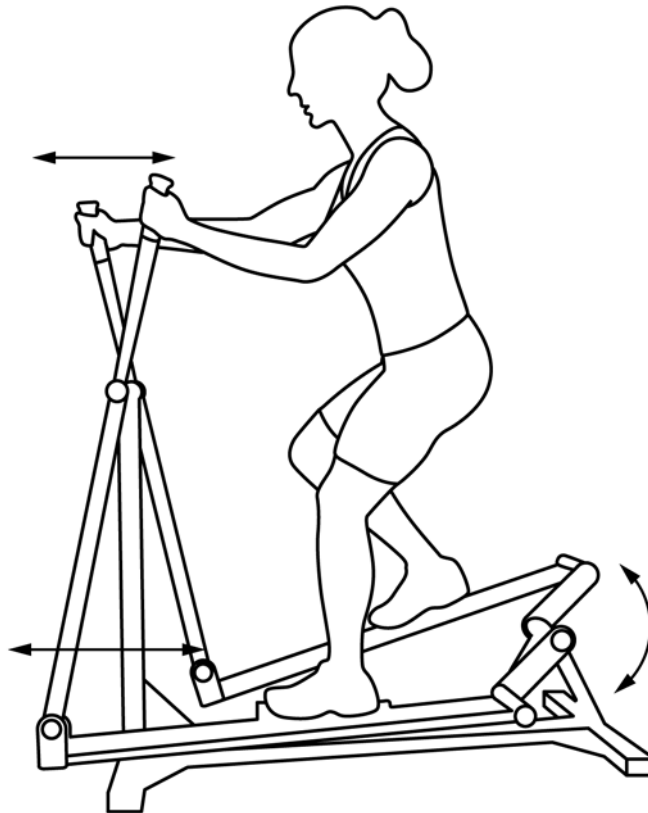

FIG. 3 Swinging Apparatus

lift the user but potentially utilizes rapid cyclical movement of equipment joints and linkages. Examples include ellipticals, airwalkers, stepper machines.

## 6. Materials and Construction

6.1 *General Requirements*—Outdoor fitness equipment shall be manufactured and constructed only of materials that have a demonstrated durability in an outdoor setting. Any new materials being considered by manufacturers shall be tested

accordingly for durability by the outdoor fitness equipment manufacturer. When choosing materials, the manufacturer should take into account entrapment and entanglement hazards that can occur through distortion and degradation of materials during use or from environmental factors and or vandalism.

6.1.1 Metals shall be protected from rust or corrosion by painting, powder coating, galvanizing, or through other treatments. Plastics and other materials that experience ultraviolet

(UV) degradation shall be protected against ultraviolet light through coating or other protective means.

6.1.2 Regardless of the material or the treatment process, the manufacturer shall ensure that all materials comply with the Consumer Product Safety Improvement Act of 2008 (CPSIA) (this includes but is not limited to coating and substrate) or other applicable standards in effect in the country of installation.

6.1.3 Wood intended for outdoor fitness equipment that is not naturally rot and insect-resistant shall be treated to resist rot and insect attack. Any wood not naturally rot and insect-resistant, which has any fabrication up to 150 mm (5.9 in.) above or below the level of the protective surface of the installation, shall be treated after the wood fabrication. Deviations shall have independent documentation of durability. Chromated copper arsenate (CCA), creosote, pentachlorophenol, tributyl tin oxide, and surface coatings that contain pesticides shall not be used for outdoor fitness equipment. Wood treaters and outdoor fitness equipment manufacturers shall practice technologies and procedures that minimize the level of dislodgeable toxin.

6.1.3.1 Wood components shall be designed in such a manner that precipitation can drain off freely and not accumulate or pool on the wood surface.

6.1.3.2 Wood surfaces shall be of materials constructed, finished and maintained to minimize the tendency for splintering.

6.1.3.3 Metal fastening systems used in wood structures or apparatus shall consider the wood treatment process of the wood material and be of suitable material to resist corrosion when exposed to the wood material and the environment.

6.1.3.4 Plywood shall be exterior or marine grade and be protected from exposure to moisture.

6.2 *Fasteners*—All fasteners used to construct public outdoor fitness equipment shall be manufactured in accordance with Guide **F1077**.

6.2.1 All fasteners, connecting, and covering devices shall be inherently corrosion resistant or be provided with a corrosion-resistant coating.

6.2.2 When installed in accordance with the manufacturer's instructions, fasteners, connecting, and covering devices shall not loosen or be removable without the use of tools. Lock washers, self-locking nuts, or other locking means shall be provided for all nuts and bolts to protect them from detachment. Hardware in moving joints shall also be secured against unintentional loosening.

6.2.3 Hooks and connecting devices shall be subject to the requirements of Sections **7** and **8**.

6.3 Moving suspended components shall be connected to the fixed support with bearings or bearing surfaces that serve to reduce friction or wear.

6.4 Steel cable that is permanently affixed to a hanger assembly performs as a bearing surface. Cable ends should be inaccessible or capped to prevent injury from frayed wires. Cables and steel-cored ropes should be protected to prevent fraying, loosening, unraveling, or excessive shifting of joints.

6.5 Plastic, rubber and other synthetic materials shall be specified with consideration given to environmental degradation. These components shall be designed and installed where inspection can be performed easily.

## 7. Design and Performance Requirements

7.1 *General Requirements*—Unless otherwise stated, outdoor fitness equipment shall meet the requirements set forth in this specification.

7.2 Outdoor fitness equipment represented as complying with this specification shall meet all applicable requirements specified herein. Anyone representing compliance with this specification shall keep such essential records as are necessary to document any claim that the requirements within this specification have been met.

7.3 Outdoor fitness equipment shall be anchored to the ground and not intended to be moved from its installation point during use or by the user.

### 7.4 *Support:*

7.4.1 Outdoor fitness equipment shall support the user and any additional loads applied by the user in normal operation without breakage.

7.4.2 Loading requirements for outdoor fitness equipment are set forth in Section **8** of this specification.

### 7.5 *Edges, Corners, and Tube Ends:*

7.5.1 *General*—There shall be no accessible sharp points or sharp edges on outdoor fitness equipment.

7.5.2 *Edges*—All edges in accessible areas shall be free of burrs and sharp edges.

7.5.3 *Corners*—All corners in accessible areas shall be radiused or chamfered.

7.5.4 *Tube Ends*—The exposed open ends of all tubing shall be provided with caps or plugs that cannot be removed without the use of tools.

7.6 *Protrusions*—Protrusion hazards shall not be present on outdoor fitness equipment.

7.6.1 Three projection test gauges (shown in **Fig. A1.10**) and a projection gauge (shown in **Fig. A1.11**) are required to determine whether projections are protrusions. Their use is described in this section.

7.6.2 *Accessible Projections*—A projection is not accessible and is not a protrusion when it is recessed or located in such a manner that will not allow any of the projection test gauges to be placed over it. Any of the conditions described in the remainder of this section constitute a protrusion hazard.

7.6.3 *Determining Whether a Projection is a Protrusion*—Successively place each of three gauges (see **Fig. A1.10**) over each accessible projection in all orientations (see **Fig. A1.12** and **Fig. A1.13**). Determine whether the projection extends beyond the face of any gauge. The projection fails the test and is a protrusion if it extends beyond the face of any of the three gauges.

7.7 *Entanglement*—Entanglement hazards 610 mm (24 in.) or higher from the ground surface shall not be present on outdoor fitness equipment.

7.7.1 Three test gauges, a feeler gauge, and the means to accurately measure a 3.0 mm (0.12 in.) extension are required to determine whether entanglement hazards exist. Any of the conditions described in this section constitutes an entanglement hazard.

7.7.1.1 A projection that meets both of the following requirements is an entanglement hazard:

(1) One of the three projection gauges (see Fig. A1.10) passes over the projection and contacts the initial surface.

(2) The projection extends perpendicular ( $\pm 5^\circ$ ) from the initial surface more than 3.0 mm (0.12 in.). The thickness of the projection gauge (see Fig. A1.11) may be used to measure the 3.0 mm (0.12 in.) extension.

7.7.2 *Projections from a Horizontal Plane*—A projection that meets the conditions of 7.7.1.1(1) and (2) and which also projects upwards from a horizontal plane (see Figs. A1.14–A1.16) is an entanglement hazard.

7.7.3 *Exposed Bolt End Projections*—Any accessible bolt end projecting beyond the face of the nut more than two full threads is an entanglement hazard (see Fig. A1.16(6)). A bolt end is inaccessible and not an entanglement hazard when the bolt end is recessed and the 89 mm (3.5 in.) OD projection gauge (see Fig. A1.10) cannot be made to contact the bolt end when the outside curve of the gauge is placed flat against the recessed area (see Fig. A1.15).

7.7.4 *Projections Which Increase in Size*—Any projection which fits within any of the three projection test gauges (see Fig. A1.10) and where the increase in size extends greater than 3.0 mm (0.12 in.) from the initial surface with a depth greater than 3.0 mm (0.12 in.) is an entanglement hazard (see Fig. A1.16).

7.7.5 *Connecting Devices*—Connecting devices such as, but not limited to, quick links, when properly closed, are not entanglement hazards. These connectors are considered closed when there is no gap or space greater than 1.0 mm (0.04 in.) when measured with a feeler gauge.

#### 7.8 *Guarding and Entrapment in Accessible Areas:*

7.8.1 *General*—Shear, pull-in and crush points shall be avoided or guarded. There shall be no crush or shear points caused by junctures of two components moving relative to one another, or at an opening present at the junction of a stationary support and a rigid supporting member for a swinging component while the swinging components travel through their complete range of travel. A crush or shear point is any point that entraps at one or more positions a 25.00 mm (0.98 in.) diameter rod.

7.8.2 To reduce the likelihood of unintentional contact with a crush or shear point, an opening shall comply with either 7.8.2.1 or 7.8.2.2.

7.8.2.1 An opening with a minor dimension of less than 25 mm (1.0 in.) is acceptable if a finger probe (as illustrated in Fig. A1.17), when inserted into an opening, cannot be made to touch any crush or shear point. The probe shall be applied in all possible positions (Fig. A1.18) with an application force not to exceed 4 N (1 lb).

7.8.2.2 An opening in an enclosure with a minor dimension of 25 mm (1.0 in.) or more, shall require that the crush or shear

point be located at a distance as specified in Table 1 from the plane of the opening. An enclosure in this case covers a crush or shear point.

7.8.3 *Component(s) Moving Past Fixed Component(s)*—If during the intended operation or adjustment, a component moves past a fixed component in such a manner that no shear or crush points are created, then the spacing between the fixed component and the moving component shall be less than 8 mm (0.32 in.) or greater than 25 mm (0.98 in.). If during the intended operation or adjustment, a component moves past a fixed component in such a manner that a scissors action is created, then the spacing between the fixed component and the moving component shall be 60.0 mm (2.4 in.) or greater.

7.8.4 *Component(s) Moving in Proximity to the Ground*—If during the intended operation or adjustment, a component moves past or towards the ground then the spacing between the component and the ground shall be greater than 60.0 mm (2.4 in.). If the vertically moving components are outside the user’s field of view then the distance between the parts and the ground shall be a minimum of 110 mm (4.3 in.).

7.8.5 *Component Stops*—Stops for moving components shall be guarded or inaccessible. This guarding shall not create shear points, crush points.

7.8.6 *Head and Neck Entrapment*—Outdoor fitness equipment shall be designed, constructed and assembled so that any accessible opening shall meet the performance and testing requirements set forth below. Completely and partially bounded openings below 610 mm (24 in.) are exempt from this requirement.

7.8.6.1 Outdoor fitness equipment shall meet the following performance requirements to reduce the risk of accidental head or neck entrapment by either a head-first or feet-first entry into the opening. Openings between the protective surfacing and the bottom edge of the equipment (that is, rails, platforms, steps, and so forth) are exempt from this requirement as indicated by Fig. A1.1.

(1) *Accessible Openings*—A completely bounded rigid opening is accessible when a torso test probe (see Fig. A1.2) can be inserted into the opening to a depth of 102 mm (4.0 in.) or more.

(2) *Test Procedure for Completely Bounded Rigid Openings*—Place the torso probe (see Fig. A1.2) in the opening with the plane of the base of the probe parallel to the plane of the opening; rotate the probe to its most adverse orientation (that is, major axis of the base of the probe parallel to the major

**TABLE 1 Minimum Acceptable Distance from an Opening to a Crush or Shear Point**

Minimum Dimension of Opening, <sup>A</sup> mm (in.), $\pm 0.05^B$	Minimum Distance from Opening to Part, mm (in.)
25 (1)	165 (6.5)
32 (1.25)	190 (7.5)
38 (1.5)	318 (12.5)
48 (1.875)	394 (15.5)
54 (2.125)	445 (17.5)
More than 54 (2.125) and less than 152 (6)	762 (30)

<sup>A</sup> See 7.8.2.2.

<sup>B</sup> Between 25 and 64 mm (1 and 2.5 in.) interpolation is used to determine values specified in the table.

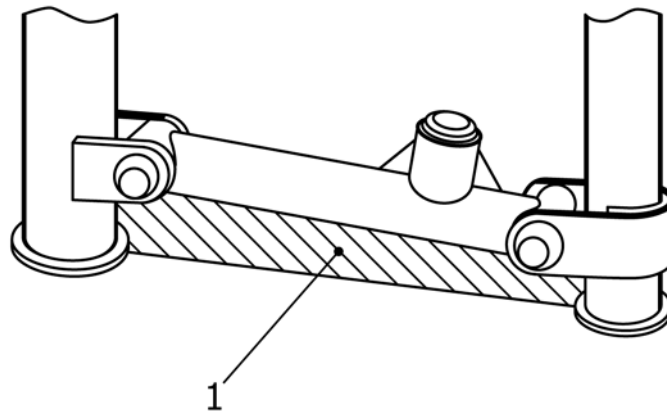

FIG. 4 Ground Clearance 60 mm (2.4 in.)

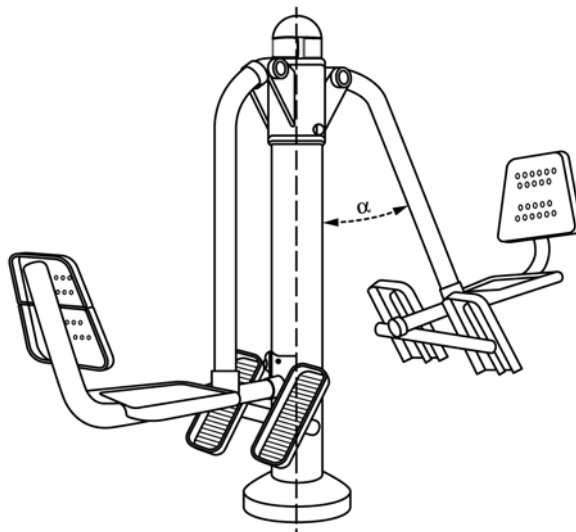

FIG. 5 Pendular Motion Machine

axis of opening). If the torso probe can be inserted into the opening to a depth of 102 mm (4.0 in.) or more, place the head probe (see Fig. A1.3) in the opening with the plane of the base of the probe parallel to the plane of the opening. An opening passes this test if (1) the opening does not admit the torso probe when it is rotated to any orientation about its own axis, or (2) the opening admits the torso probe and also admits the head probe. An opening fails the test if the opening admits the torso probe but does not admit the head probe.

7.8.6.2 *Boundaries of Large Openings*—If the opening admits the 229-mm (9.0-in.) head probe, each portion of its boundary shall be evaluated for partially bounded opening requirements of 7.8.6.3.

7.8.6.3 *Partially Bounded Openings:*

(1) A partially bounded opening is considered accessible when any of the following conditions exist, and must meet the performance requirements as recommended in 7.8.6.3(2) and 7.8.6.3(3).

(2) If the unbounded part of a partially bounded opening is between 47.6 mm (1.875 ± 0.005 in.) and 229 mm (9.0 in.) in width when measured perpendicular to each surface, the

opening can be considered accessible and must meet the conditions of 7.8.6.3(3).

(3) *Test Method*—The “A” portion of the test template (Fig. A1.4) is to be inserted along the centerline of the opening (determine the most adverse condition) (see Fig. A1.5) so that the centerline of the template follows the centerline of the opening and the plane of the template is parallel to the plane of the opening until the motion is arrested by contact between the test template and the boundaries of the opening. By visual inspection, determine if there is simultaneous contact between the sides of the template. If simultaneous contact is made the opening is accessible and must be tested using the “B” portion of the test template (see Fig. A1.6).

(4) If the angle test template “A” indicates failure, check for an exempted thick surface condition by positioning the plane of the “B” portion of the test template between and perpendicular to the plane of the boundaries of the opening (see Fig. A1.7 and Fig. A1.9). If the test template fits completely within the boundaries of the opening, the opening is considered hazardous and fails the test unless it allows full passage of the 229 mm (9.0 in.) head probe (see Fig. A1.8). If the template



does not fit down within the boundaries of the opening (defined as the opening outlined by the contact points of the test template “A”) the opening is not considered accessible.

(5) The test template is divided into two sections. Section “A” is used first to determine accessibility. Section “B” is used to determine if the thickness of the material or the location of the opening prevents access to the opening. The thickness of 19.1 mm (0.75 in.) for the template itself is based on half of the neck depth of a 5th percentile two year old minus compression.

**7.9 Pendular, Pivoting or Swinging Motion**—Outdoor fitness equipment that functions with a swinging or pendular motion shall be fitted with dampened end-stops or other appropriate movement limitation systems. End-stops shall be kept inaccessible. The portion of the equipment going through pendular motion shall not exceed a range of motion of over 70°. See Fig. 5.

**7.9.1 Materials subject to loss of impact attenuation** shall be addressed by the manufacturer per maintenance requirements specified in Section 12.

**7.9.2 Suspended Components**—Suspended components, such as rings on upper body equipment, shall be smoothly finished and have a minimum radius of 6.35 mm (0.25 in.) on all corners and edges.

**7.9.3 Bearing Surfaces**—All pivot points shall be designed with load and environment appropriate bearing materials.

**7.10 Adjustment and Locking Means**—All adjustment and locking means shall function securely at all adjustment positions. The possibility of inadvertent disengagement shall be reduced by spring retention, clamps, or other means.

**7.10.1 Adjustment knobs and levers** shall not interfere with the user’s range of movement.

**7.11 Handgrips/Foot Support:**

**7.11.1 General**—Handgrips and foot supports on outdoor fitness equipment shall not create protrusions or entrapment hazards. If surfaces are intended to be gripped for the execution of the exercise then they shall have a cross sectional dimension greater than 16.00 mm (0.63 in.) in any direction. Functional training grips are exempt from these requirements. Material used for gripping surfaces shall take into consideration environmental degradation and vandalism.

**7.11.2 Integral Handgrips**—Integral handgrips, if required for proper use as defined by the manufacturer, shall be conspicuous and shall reduce slippage during normal use and not create entrapment or entanglement points.

**7.11.3 Applied Handgrips**—Applied handgrips shall be of a material that reduces slippage and shall withstand an applied force of 90 N (20.2 lb) without movement in the direction of the applied force.

**7.11.4 Rotating Handgrips**—Rotating handgrips shall be constrained against lateral movement along their rotational axis and be constructed of a material that reduces slippage.

**7.11.5 Foot Supports**—Bars or plates intended to support the user’s feet during exercise shall be fitted with or be of a material or surface type or configuration that reduces slippage.

**7.11.5.1 Foot Supports on Swinging Apparatus**—On outdoor fitness equipment that is intended to be set in motion by the user (ellipticals, air walkers, etc. where body weight is

mainly supported on the foot supports) the foot support shall have a minimum support surface of 320.0 mm × 120.0 mm (12.6 in. × 4.7 in.) and include an edge surface of at least 10.00 mm (0.39 in.) around three sides of the foot support to assist in preventing the user’s foot from slipping off. Circular footrests shall be at least 250.0 mm (9.8 in.) in diameter and shall not be built with a foot holder. The footrest system shall be designed in a way that ensures the user’s feet cannot get trapped, enabling the user to freely step off the equipment at any point in the movement.

**7.12 Load Development and Load Transmitting Components**—Load development and load transmitting components, including all attachment devices (links, shackles, end fittings, and termination means) shall not fail with a load equal to five times the maximum static tension developed by the machine during normal operation.

**7.13 Engagement Means**—All portions of the equipment designed or intended to be used by the user of the equipment shall meet the intrinsic and or extrinsic loading parameters set forth in section 8 of this standard.

**7.14 Ropes, Belts, Cables, or Other Load Transmitting Means:**

**7.14.1 General**—Ropes, belts, cables, and other means, including all attachment devices (links, shackles, end fittings, and termination means) shall not fail with a load equal to five times the maximum static tension developed by the machine during operation and shall pass the endurance guidelines set forth in Section 8. All end terminations shall not be subjected to cyclic bending under normal and intended machine operation as defined by the manufacturer. Exposed ends or strands of cables or wire ropes shall be protected or flush with the ferrule so that puncture or entrapment cannot occur.

**7.14.2** The metals used in cables shall be corrosion resistant.

**7.14.3** Cables or ropes used for climbing shall be restrained at both ends.

**7.14.3.1** Rope or cable with a length of 178.0 mm (7.0 in.) or less may be attached at one end only or shall be fixed at both ends and not be capable of being looped back on itself, creating an inside loop perimeter greater than 127.0 mm (5.0 in.) Multiple lengths of such cords that can contact each other would be treated as one length of cord.

**7.15 Support Posts and Foundations** for outdoor fitness equipment shall not pose a tripping hazard.

**7.16 Fall Height Requirements**—The fall height of outdoor fitness equipment shall be the distance between the highest designated use surface and the protective surface below.

**7.16.1** Equipment support posts with no designated use surfaces have no fall height requirement.

**7.16.2** Equipment where the user assumes a vertical standing position on the ground or a sitting position with feet on the ground during the equipment’s intended use has no fall height requirement.

**7.17 Design for Accessibility**—Outdoor fitness equipment designed for accessibility by users with functional limitations or impairments shall meet additional criteria outlined in Specification F3021.

## 8. Structural Integrity

8.1 Setup and procedures for the structural integrity tests are set forth in the test method and are intended to be conducted by manufacturers on equipment at a test site or their facility and are not intended to be performed on equipment installed in the use zone or as part of a routine maintenance program.

### 8.2 Loading Test Criteria:

8.2.1 The test load shall be applied as defined in Test Methods **F2571** through appropriate load distribution devices.

8.2.2 After conducting the tests there shall be no visible crack or breakage of any component and no form of permanent deformation of any component that may adversely affect the structural integrity or safe use of the equipment. If the deformation results in clearances falling below those specified in section 6 and elsewhere in this document (or the other referenced documents) then the safety of the apparatus or equipment shall be deemed compromised. After removal of the load, hooks, shackles, rings, or links shall not have opened to more than 1.02 mm (0.04 in.).

8.3 *Intrinsic Loading*—All user supporting surfaces for outdoor fitness equipment shall be able to withstand static loads equal to a safety factor of 4 times the greater of 135.0 kg (297.0 lb), or the maximum specified user weight, as set forth by the manufacturer, at the point of user contact without breakage. If there are multiple user contact surfaces or if the equipment is designed for more than one user at a given time then the equipment shall be subjected to multiple loads dependent on the maximum number of intended users.

8.4 *Extrinsic Loading*—The fitness equipment and user supports shall not break when loaded by the maximum specified user(s) weight and the maximum extrinsic load as specified by the manufacturer.

8.4.1 The test load to be applied for 8.4 is specified by the following equation:

$$F_{test} = 4(W_p + 1.5 F_a) \quad (1)$$

where:

$F_{test}$  = the total reactionary load to be applied during the test, expressed in kilograms or pounds depending on the values  $W_p$  and  $F_a$ .

$F_a$  = the maximum extrinsic load at the point of user contact with the machine for the maximum capacity of the machine as stated by the manufacturer, expressed in kilograms or pounds,

$W_p$  = the proportionate amount of the user's body weight being applied to the machine component being tested. This value is to be expressed as the proportionate amount of either 135 kg (297 lb) or the maximum user weight as specified by the manufacturer, whichever is greater,

1.5 = dynamic coefficient, and

4 = factor of safety.

8.4.2 Extrinsic loads calculated in 8.4.1 are to be applied to all machine components receiving extrinsic loads from operation of the machine according to the manufacturer's operating instructions. Examples of areas to conduct this testing include seats and lifting arms. As with intrinsic loads, composite

outdoor fitness structures shall be evaluated for extrinsic loads based upon the maximum number of intended users and the maximum loads that the equipment may be subject to during its intended use as set forth by the manufacturer.

8.5 *Handlebar / Grip Loading*—Handlebars and gripping surfaces that support fully the user's body weight, shall meet the loading parameters of 8.3 without breakage. In general, handlebars or gripping surfaces that do not support the user's body weight, shall endure a vertical static load of the greater of  $1.0 \times 135$  kg (297 lb) or the maximum user weight without breakage. Handlebars and gripping surfaces shall endure a load of  $0.5 \times 135$  kg (297 lb) in all other directions without breakage.

8.6 *Seat Assemblies*—Seat assemblies shall pass either the intrinsic and extrinsic load parameters of 8.3 and 8.4 without breakage or an endurance load of the maximum user weight or 135 kg (297 lb), whichever is greater, for the prescribed number of cycles set forth in 8.7. Upon completion of the endurance test the seat assembly shall be subjected to a static load test of 1.5 times the maximum user weight or 200 kg (440 lb), whichever is greater.

8.7 *Endurance Loading*—The components of outdoor fitness equipment that provide a resistance means and the components that transmit that load shall not fail when cycled as intended by the manufacturer at maximum user load for a minimum of 80 % of the range. As a minimum, outdoor fitness equipment shall withstand 250,000 cycles at the maximum specified load over a minimum of 80 % of the possible range of movement.

8.7.1 *Multiple Exercise Stations or Composite Fitness Structures*—When the equipment consists of two or more separate functional units or exercise stations, each station shall withstand the endurance load test. When more than one function is to be tested, any common components may be replaced prior to commencing the next test.

8.7.2 *Exercise Stations with Common Frame*—Fitness equipment may have several exercise stations sharing a common frame. In this case, the frame shall withstand 500,000 cycles. The frame may be replaced during the test period if the number of stations to be tested causes the frame to experience cycles in excess of the numbers stated above.

8.7.3 Tests for endurance shall apply loads to the machine in the same manner that the machine is loaded when it is operated in accordance to the manufacture's operation instructions.

8.7.4 After the test, the equipment shall be capable of functioning as specified by the manufacturer, without increasing the risk of injury to the user.

## 9. Equipment Layout

9.1 *Discussion*—The separation between adjacent pieces of outdoor fitness equipment shall consider the "training envelope" and the "clearance space". Their definitions can be found in Section 3. The separation distance shall also take into consideration the fall height of the equipment as defined by the manufacturer. These spaces shall consist of obstacle-free surfacing that conforms to Specification **F1292** appropriate for the fall height of the equipment. The minimum clearance space,

outside of the training envelope for each piece of outdoor fitness equipment, shall be at least 900 mm (36 in.) in width. In addition, for US installations, there shall be a rectangular zone measuring 762.0 mm (30.0 in.) × 1219.2 mm (48.0 in.) adjacent to the equipment, for “parking” mobility aides while the equipment is in use. In addition to the clearance space an accessible route 914.4 mm (36.0 in.) in width, shall be provided. The surfacing of the accessible route shall meet the requirements of Specification **F1951**. These requirements are for US installations of outdoor fitness equipment.

9.1.1 The clearance spaces of adjacent outdoor fitness equipment may overlap, but shall not extend into the training envelope of the adjacent apparatus. The clearance spaces for two or more stationary fitness equipment structures that are not physically attached but are functionally linked shall be determined as if the separate equipment were parts of a composite fitness structure.

9.1.2 Moving fitness equipment such as elliptical and air walker style equipment shall be located in positions away from the clearance spaces of other fitness equipment (in the direction of their operation).

9.1.3 Overhead obstructions (for example, tree limbs) within the clearance spaces of outdoor fitness equipment, that are not part of the equipment, shall be avoided.

9.1.3.1 All overhead utility line clearances above the clearance space areas shall comply with all local, state, and national codes, such as the National Electrical Safety Code.

9.1.4 Outdoor fitness equipment that is intended for a user to maintain contact with the ground during use either in a standing or sitting position and no reasonably foreseeable method to elevate the user has no individual impact attenuating surfacing requirements.

9.2 Outdoor fitness equipment may be constructed as free-standing structures, may be in combination with other fitness equipment, or may be part(s) of a composite fitness structure.

9.3 The training envelope, through which the user and the apparatus operate, shall be defined by the manufacturer. The minimum training envelope dimensions shall be defined by the position that user assumes on the machine while using it.

9.3.1 The training envelope for two or more pieces of adjacent outdoor fitness equipment shall not overlap.

#### 9.4 *Composite Fitness Structures:*

9.4.1 The boundary of the clearance space for a composite outdoor fitness structure shall be composed of those clearance spaces that have been established for each individual fitness structure that, when joined together, comprise the composite fitness structure.

9.4.2 Professional judgment of fitness equipment manufacturers, designers, and owner/operators shall be used when designing a composite fitness structure to eliminate hazards created by conflicts in circulation use patterns or close proximity of adjacent components, or both.

9.5 In settings where periodic overcrowding is likely, a supplemental circulation area beyond the clearance space is recommended. Provision of such a supplemental circulation area shall be contingent upon the professional judgment of the designer or owner/operator.

9.6 Outdoor fitness equipment shall not be placed within defined children’s playground areas. Outdoor fitness equipment shall be separated from the use zones for playground equipment by fencing, mounds, pathways, landscaping or other barriers.

9.7 Outdoor fitness equipment placement and installation shall meet the DOJ 2010 Standard for Accessible Design requirements for accessible routes, passage/turning areas and surfacing or applicable standards in the country of installation.

## 10. Installation

### 10.1 *Manufacturer’s Responsibilities:*

10.1.1 The manufacturer shall provide clear and concise instructions and procedures for the assembly, installation, operation and maintenance of each piece of outdoor fitness equipment provided as set forth in Section 11.

10.1.2 Installation instructions shall include detailed requirements for mounting the equipment to the ground including recommended fasteners and their minimum pullout strength and/or torquing requirements.

10.1.3 Installation instructions shall include detailed descriptions of the intended exercises to be performed on the equipment and their respective training envelopes and clearance spaces.

### 10.2 *Owner’s/Operator’s Responsibilities:*

10.2.1 The owner/operator shall follow the manufacturer’s instructions and procedures when installing all outdoor fitness equipment.

10.2.2 The owner/operator shall install protective surfacing accordance with Specifications **F1292** and **F1951**, as applicable.

10.2.3 Once the equipment has been installed, the installation inspection should be carried out by a qualified inspector to assess conformity with the requirements given in this standard and adherence to the recommendations set forth by the manufacturer.

## 11. Maintenance

11.1 The manufacturer of outdoor fitness equipment shall provide inspection, maintenance, and repair instructions, including, but not limited to, what, when, and how to inspect, maintain, and repair. Attention shall be called to using only manufacturer supplied or recommended parts when servicing the equipment. Alterations or changes to the components are not allowed. The requirements for these instructions are set forth in Section 14.

11.1.1 The manufacturer shall give guidance as when to replace components that are difficult to determine the appropriate service life. Special attention shall be given to plastics, rubber and synthetics that may become brittle or degrade from environmental exposure.

### 11.2 *Protective Surfacing:*

11.2.1 The owner/operator shall maintain the protective surfacing within the clearance space of the outdoor fitness equipment in accordance with Specifications **F1292** and **F1951** where applicable.



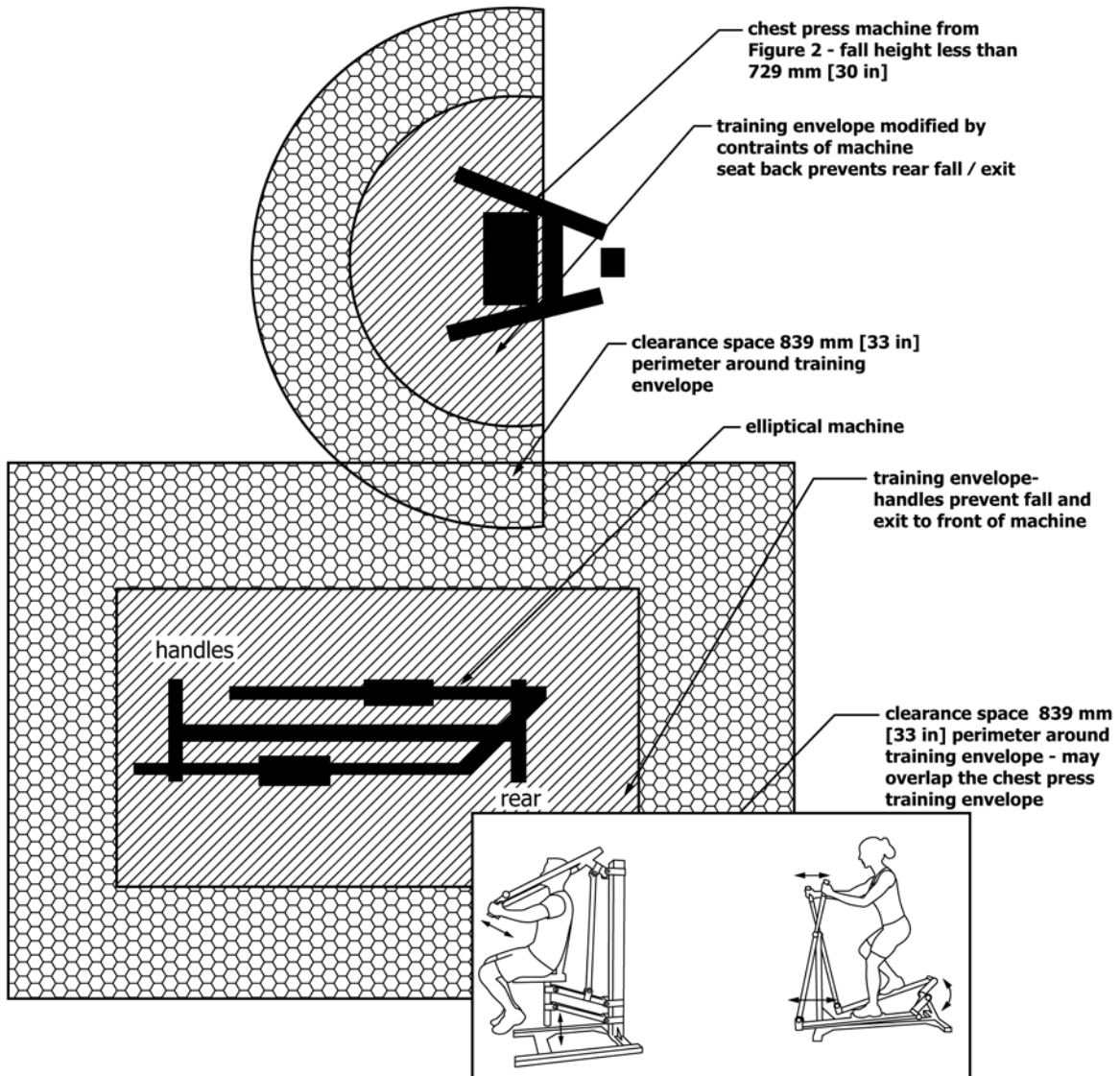

FIG. 6 Machine Layout

11.2.2 The owner/operator shall keep the training envelope and clearance space of the outdoor fitness equipment free from extraneous materials that could cause injury, infection, or disease.

11.3 *Records*—The owner/operator shall establish and maintain detailed installation, inspection, maintenance, and repair records for each piece of outdoor fitness equipment.

**12. Manufacturer Identification**

12.1 All outdoor fitness equipment shall have identification affixed to the product indicating the following:

12.1.1 The manufacturer’s or distributor’s, or both, contact information.

12.1.2 Serial and model numbers.

12.1.3 Date of manufacture or code number, which includes the date and manufacture.

12.1.4 User weight restrictions if the equipment is designed for a maximum user weight of less than 136 kg (300 lb).

12.2 The manufacturer’s identification shall conform to the durability requirements of UL 969, and shall be placed in a readily accessible location on the outdoor fitness equipment.

**13. Signage and Labeling**

13.1 Signage for outdoor fitness equipment shall meet the parameters set forth in Specification F1749 and ASNI Z535.1, Z535.2 and ANSI Z535.4. Signage and labels shall meet the durability requirements of UL 969. Manufacturers shall provide listing of the labels and signs used with their products and how to obtain them in the documentation provided with the outdoor fitness equipment.

13.1.1 Signage and labeling for outdoor fitness equipment shall include warnings, the contact information for the owner



and/or maintainer of the outdoor fitness equipment and shall be installed on the outdoor fitness equipment or be free standing signage installed in proximity to the outdoor fitness equipment.

13.2 Posting of freestanding signs and/or labels shall be the responsibility of the owner/operator of the equipment and shall be done in accordance with recommendations and / or instructions provided by the manufacturer.

13.2.1 Freestanding signs and labels, when used, shall be located outside of the equipment training envelope and shall be permanently anchored.

13.3 *Placement*—Signs and labels shall be placed so that they:

13.3.1 Are readily visible to the intended viewer, and

13.3.2 Alert the viewer to the potential hazard in time to take appropriate action.

13.4 Information communicated on signs and labels shall address but not be limited to the following messages:

13.4.1 Warning message communicating age appropriateness and to keep children under the age of 13 off of the equipment and outside the equipment training envelopes because of hazardous conditions children cannot appreciate. (See Fig. 7.)

13.4.2 Information message communicating the intended exercises to be performed on each machine or station. Ideally this information should be accompanied by illustrations showing the exercise and user placement on the machine.

13.4.2.1 ISO graphic symbols following ISO 22727 guidelines should be considered to depict proper intended use and to convey safety precautions and warnings.

13.5 *Warnings*—Warning messages shall be present and affixed onto outdoor fitness equipment and shall:

13.5.1 Warn to keep children under the age of 13 away from and off of this equipment. (See Fig. 7.)

13.5.2 Warn to remove helmets, drawstrings or accessories around the neck.

13.5.3 Warn of the possibility of hot surfaces and/or surfacing, when applicable.

13.5.4 Warn of the potential fall hazard(s) associated with use of the equipment.

13.5.5 Warn to use the equipment for the intended exercise.

13.5.6 Warn to not climb or allow climbing on the equipment or structures unless the intended use involves climbing on the equipment.

13.5.7 Warn to be aware of physical or medical limitations and to seek medical guidance prior to beginning any exercise program.

13.5.8 Warn to inspect and not use any equipment that appears damaged, inoperable or is missing components.

13.5.9 Warn to keep clear of moving parts and to be aware of the presence of other while using the equipment.

13.5.10 Warn to not attach straps, bands or similar items to the equipment unless the intended use specifically allows it.

13.5.11 Additional hazard warnings shall be provided in the form of site specific labels at locations where other hazards are present.

13.6 It is the responsibility of the owner/operator to replace signs and labels should they become illegible, destroyed, or removed. Maintenance instructions shall call the reader's attention to this.

**14. Documentation**

14.1 *Discussion*—Assembly, installation, maintenance and operation instructions and warnings shall be provided in an owner's manual. The first topic of the manual shall be a comprehensive listing of the warnings applicable to the product. It shall also include a review of the warnings placed on the equipment and the placement locations. If warnings are to be installed with the equipment on additional signage then these shall be reviewed as well. This document shall comply with ANSI Z535-6.

14.1.1 *Assembly Instructions*—An owner's manual or assembly manual shall be supplied that gives clear detailed assembly and installation instructions for the equipment.

14.1.1.1 The manual shall include a listing of the tools required for assembly and installation even if the manufacturer supplies the tools.

14.1.1.2 Installation instructions shall include detailed requirements for mounting the equipment to the ground including recommended foundations.



**NO CHILDREN UNDER AGE 13**

**FIG. 7 Example of No Children Allowed Signage**

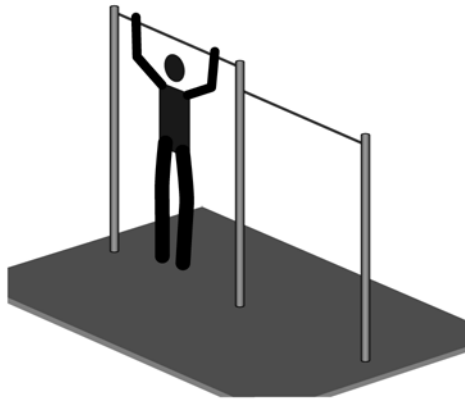

FIG. 8 ISO 22727 Graphical Representation for Chin Up Exercise

14.1.1.3 Installation instructions shall include dimensions for the training envelope, clearance space and fall height for the equipment.

14.1.2 *Equipment Parts List*—The assembly manual shall include an exploded view of the equipment and a parts list that provides part names, and part numbers or reference numbers.

14.2 *Operational Instructions*—Each intended use of the machine shall be explained in the owner’s manual or the operating instructions.

14.2.1 Operational instructions shall include the maximum user(s) weight for the equipment.

14.2.2 Operational instructions in the manual shall include the instructions and diagrams found/installed on the product. Ideally this information should be accompanied by illustrations showing the exercise and user placement on the machine.

14.2.2.1 ISO graphic symbols following ISO 22727 guidelines should be considered to depict proper intended use and to convey safety precautions and warnings.

14.3 *Maintenance Instructions*—Maintenance advice shall be provided by the manufacturer/distributor of the outdoor fitness equipment.

14.3.1 The manufacturer/supplier shall provide drawings and diagrams necessary for maintenance, inspection and repair of the equipment.

14.3.2 The instructions shall specify at a minimum:

14.3.2.1 The servicing points and method of servicing, e.g., lubrication, bolt re-tightening.

14.3.2.2 Only manufacturer supplied or authorized replacement parts shall be used.

14.3.2.3 Precautions to be used in the disposal of replaced components.

14.3.2.4 Run-in or break-in periods and what to do/inspect after those periods have elapsed.

14.3.2.5 Listing of recommended spare parts.

14.3.2.6 Minimum required inspection and maintenance schedules and that records that shall be maintained.

(1) Inspection may be divided into visual, operational weekly and monthly inspections and more thorough annual evaluations.

14.3.2.7 Required replacement schedules due to expected deterioration (e.g., environmental aging).

14.4 *Inspection Instructions*—Inspection advice shall be provided by the manufacturer/distributor of the outdoor fitness equipment. If any condition is found that compromises the intended safety of the equipment the equipment must be removed from service until repairs are made. All inspection records shall be maintained and retained by the owner of the equipment or the facility operator. At a minimum the inspection instructions shall contain the following guidelines:

14.4.1 *Routine Visual Inspection*—Procedures intended to identify obvious hazards that can result from normal use, vandalism or weather conditions.

14.4.1.1 The manufacturer shall recommend the minimum inspection frequency but the operator or facility owner should use professional judgment and base the inspection frequency on the amount of use that the facility is subjected to, the history or frequency of vandalism and recent weather or environmental conditions. Further, the operator or facility owner shall report systematic problems (issues requiring too frequent repair) to the manufacturer for review and action in design and manufacture.

14.4.1.2 Visual inspection shall concentrate on all cosmetic and mechanical components of the machine, the installation and the clearance space around the equipment. At a minimum the condition and security of all hardware, corrosion, sharp edges, missing components, wear of components, structural integrity, weld integrity, exposed foundations and degradation of surfacing around the equipment shall be noted. Inspectors shall check for the presence and condition of all warnings and signage and replace all warnings and signage that are damaged.

14.4.2 *Operational Inspection*—Operational inspection is to include functional inspection procedures that are more detailed than routine visual inspection procedures. Inspectors are required to validate, through use of the equipment, the function and integrity of the equipment. The manufacturer shall detail what is required in this inspection and the frequency at which it is to occur. At a minimum, operational inspection shall occur every 3 months.

14.4.3 *Annual Inspection*—Annual inspection shall include routine visual inspection requirements, and operational inspection requirements indicated above and any additional inspection recommended by the manufacturer. The manufacturer may

require at annual inspection that components of the outdoor fitness equipment be disassembled in order that it can be inspected adequately. If disassembly and reassembly is required then detailed instructions shall be provided by the manufacturer.

**15. Testing**

15.1 Outdoor fitness equipment shall be tested and evaluated in accordance with the above sections and applicable sections of Test Methods F2571. Test Methods F2571 details the documentation that shall be maintained. The test methods detailed for entrapment, entanglement, protrusions, crush and shear take precedence over those defined in Test Methods F2571.

15.1.1 Structural testing to the requirements set forth in this specification will require that the structure not be evaluated “on-site”. The very nature of these tests will render the structure unfit to be placed into service after the testing is complete.

15.1.2 Testing of the protective surfacing shall be in accordance with the appropriate sections of Specification F1292.

**16. Keywords**

16.1 outdoor fitness equipment; public use

**ANNEX**

(Mandatory Information)

**A1. FIGURES**

A1.1 See Figs. A1.1-A1.18.

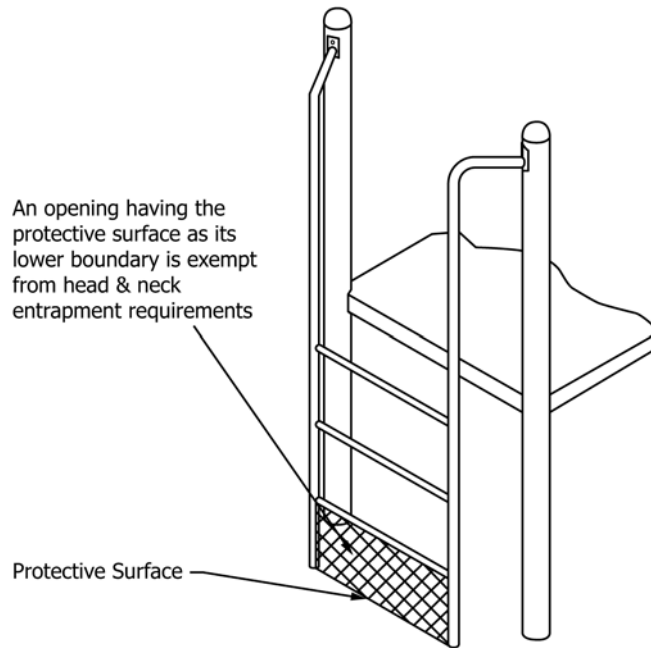

**FIG. A1.1 Exemption from Head and Neck Entrapment Requirements—Reference 7.8.6.1**

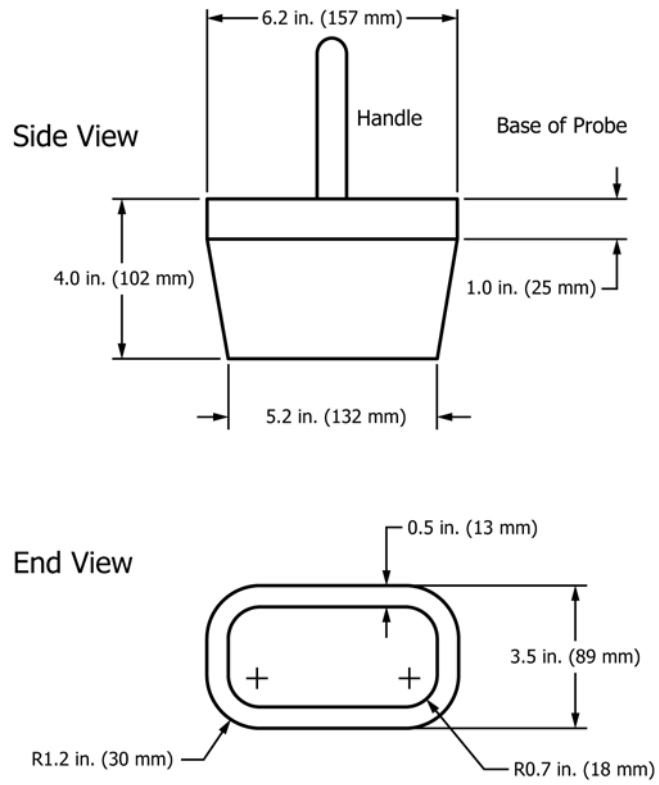

Material: Any Rigid Material

FIG. A1.2 Torso Probe—Reference 7.8.6.1(2)



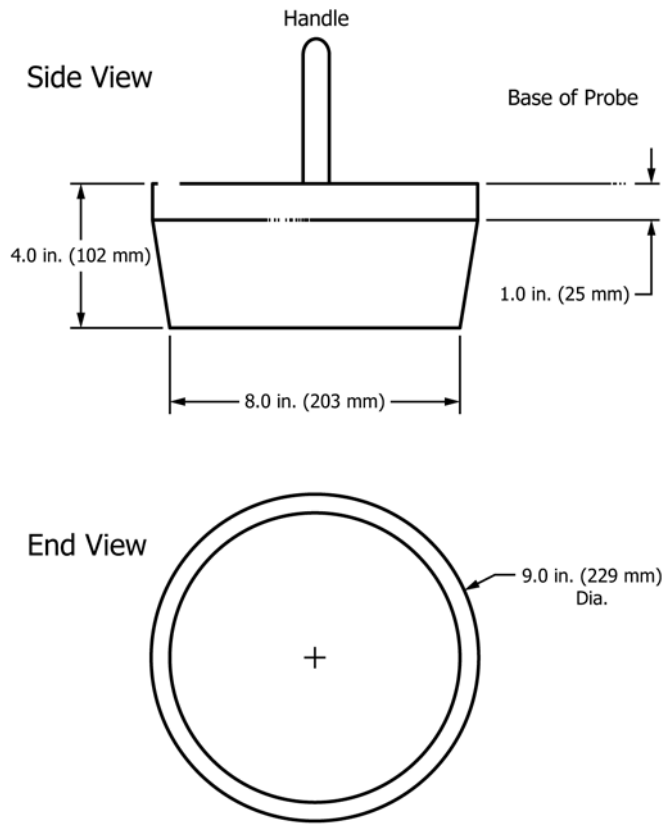

Material: Any Rigid Material

FIG. A1.3 Head Probe—Reference 7.8.6.2 and 7.8.6.3

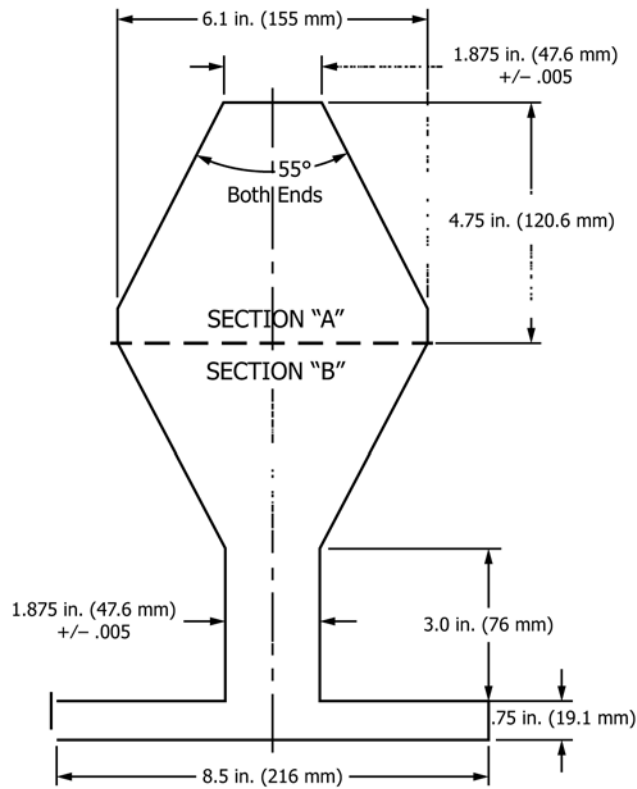

Note: Template to be constructed of any rigid material 0.75 in. (19.1 mm) thick.

FIG. A1.4 Test Template for Partially Bounded Openings—Reference 7.8.6.3

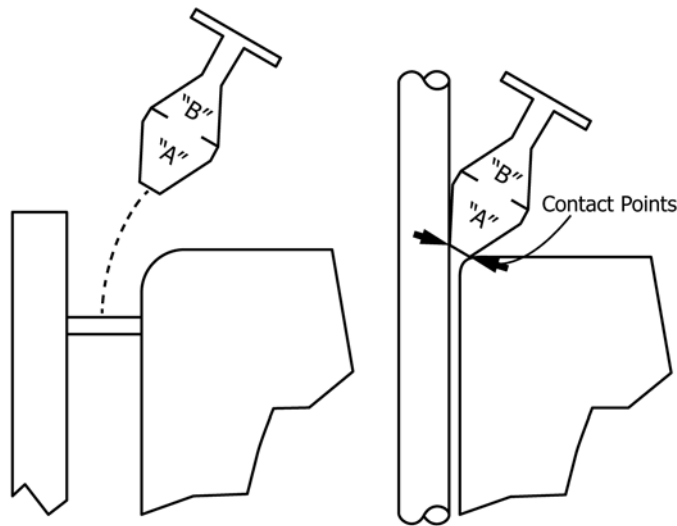

Inserting the 'A' portion of the test template into the opening following the centerline of the opening.

Upon inserting the 'A' portion of the test template into the opening, and if there is simultaneous contact between the two corners of the 'A' portion of the test template and the sides making up the boundary of the opening, the opening is considered to PASS the test.

FIG. A1.5 Inserting the Template into the Opening—Reference 7.8.6.3(3)

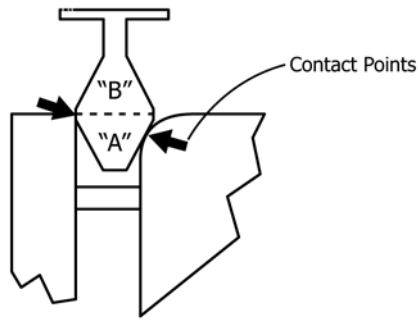

Fail - There is simultaneous contact between the two sides of the 'A' portion of the template and the sides making up the boundary of the opening. The opening should be tested further using the 'B' portion of the template.

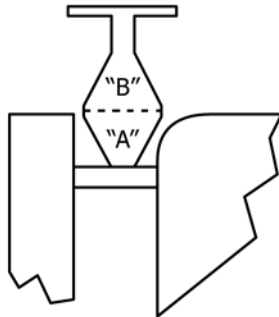

Pass - The bottom of the 'A' template is resting on the lower boundary of the opening and there is not simultaneous contact between the two sides of the template and the sides making up the boundary of the opening. Part 'B' test is not required.

FIG. A1.6 Test Template for Partially Bounded Openings—Reference 7.8.6.3(3)

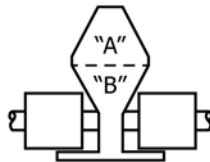

Fail - The size of the components forming the opening allows the 'B' portion of the template to pass into the opening to depth greater than 0.75 in (19.1 mm).

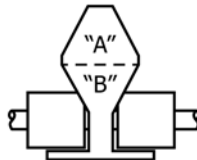

Pass - The size of the components forming the opening does not allow the 'B' portion of the template to fit within the boundaries of the opening.

FIG. A1.7 Exemption for a Thick Surface Condition Using the "B" Portion of the Test Template—Reference 7.8.6.3(4)

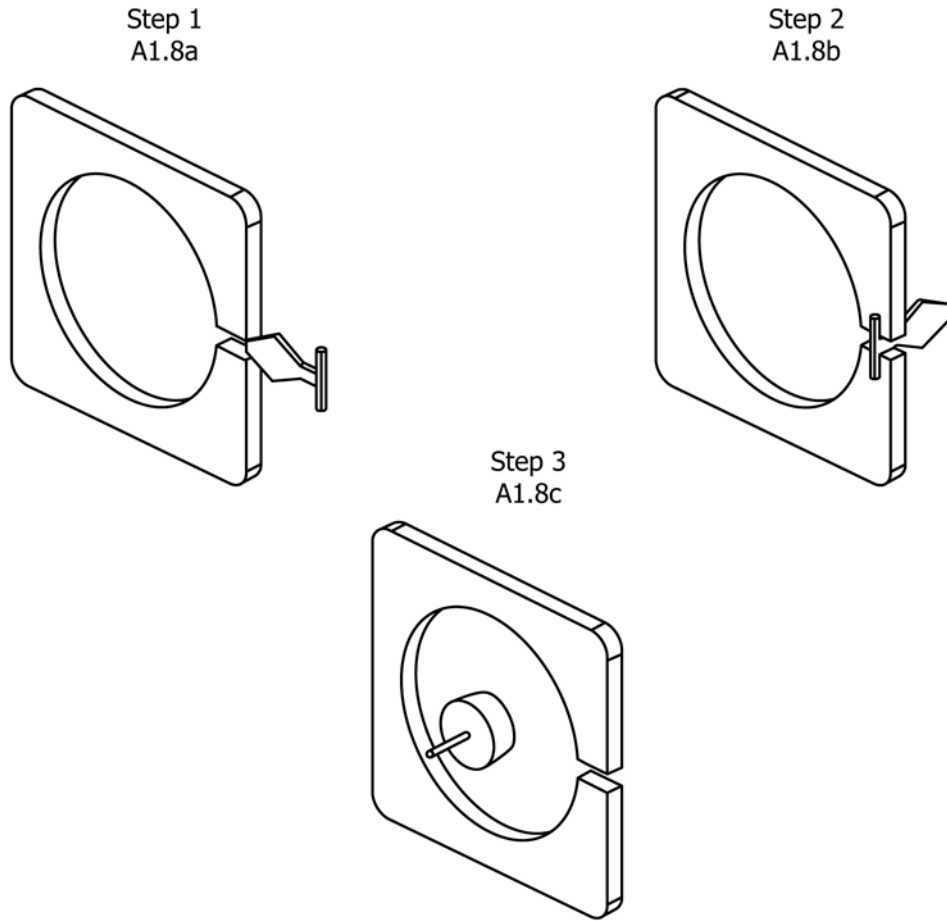

FIG. A1.8 Fig. A1.8a through Fig. A1.8c show an opening that fails the first two steps of the test method but ultimately passes because the head probe (Step 3) passes freely through the boundaries of the interior opening—Reference 7.8.6.3(4)

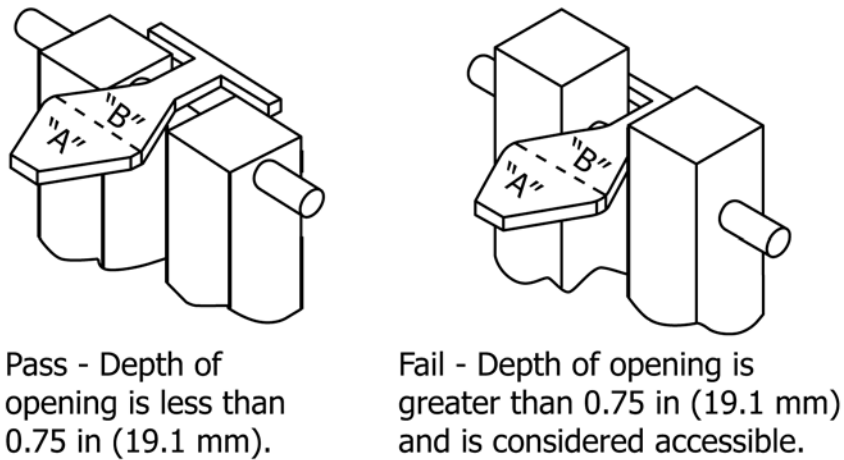

FIG. A1.9 A Partially Bounded Opening Is Not Considered Accessible if the Template Cannot Penetrate the Opening to a Depth Greater than 0.75 in. (19.1 mm) Thickness of the Test Template—Reference 7.8.6.3(4)



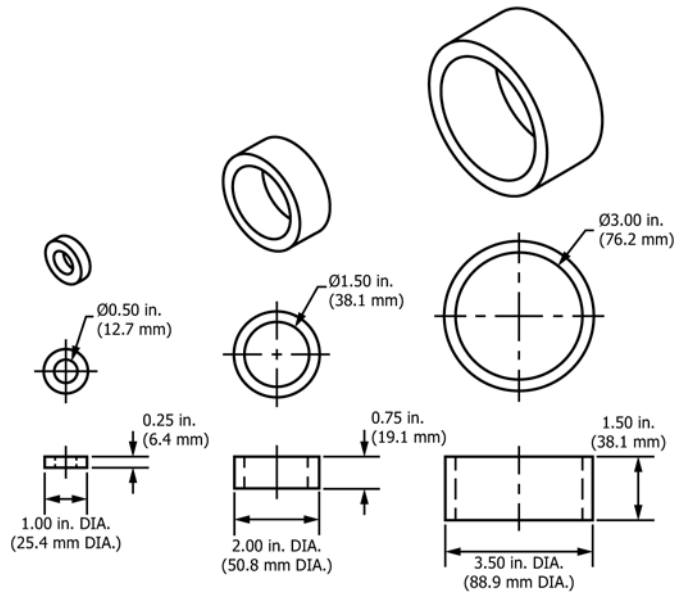
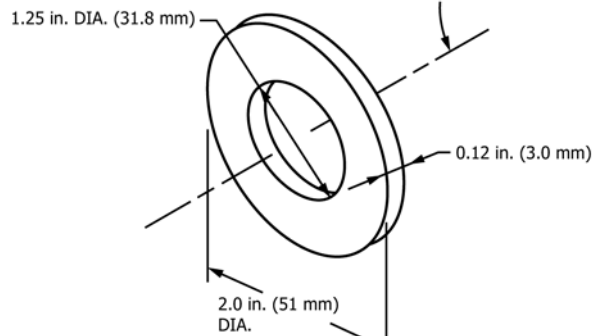

FIG. A1.10 Projection Test Gauges—Reference 7.6

Keep the face of the gauge vertical and its axis parallel to the plane of intended travel of the suspended member during the test.



NOTE: Gauge made of any rigid material.

FIG. A1.11 Projection Test Gauge—Reference 7.7.1.1

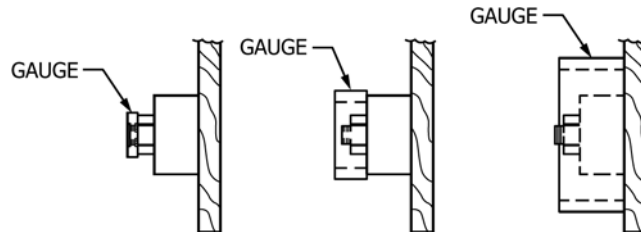

FIG. A1.12 Compound Projection Test—Reference 7.6.3

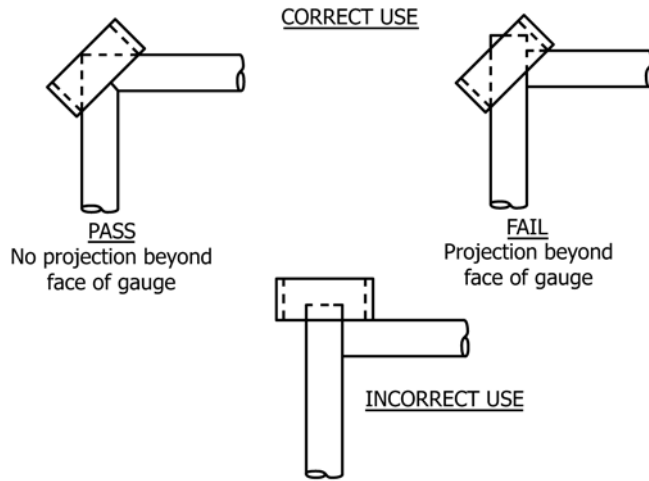

FIG. A1.13 Use of Projection Gauges—Reference 7.6.3

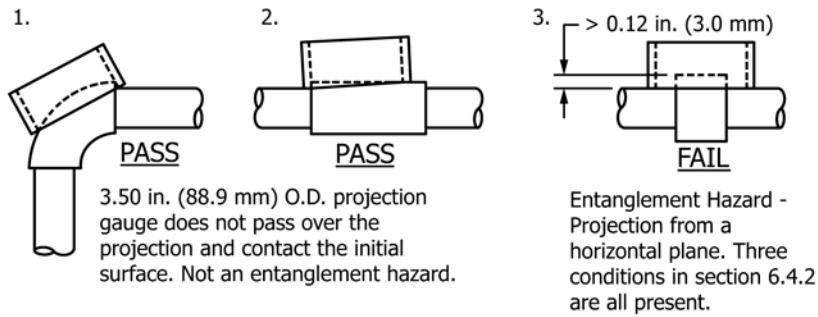

FIG. A1.14 Entanglement Test Requirement Examples—Reference 7.7.2

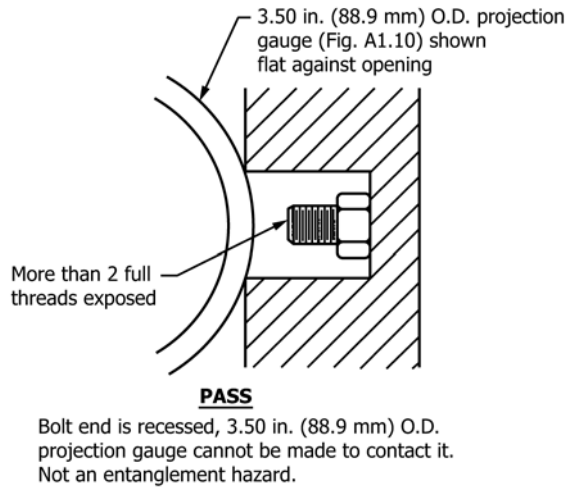

FIG. A1.15 Entanglement Test Requirement Examples—Reference 7.7.3

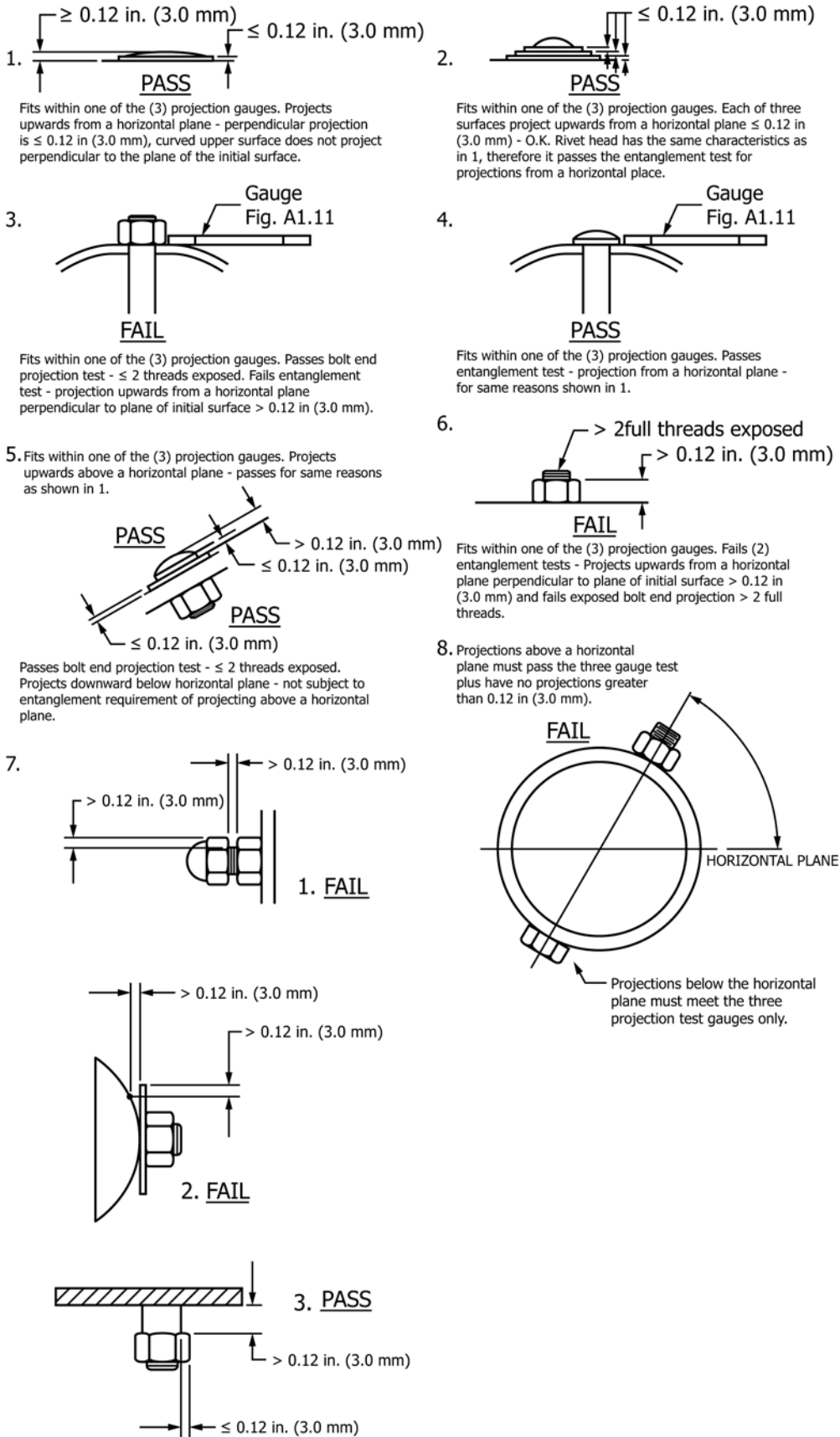

FIG. A1.16 Entanglement Test Requirement Examples—Reference 7.7.3

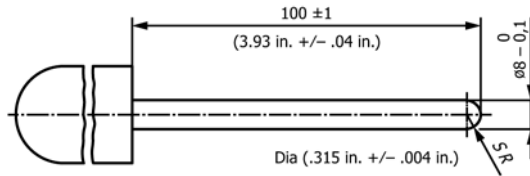

FIG. A1.17 Finger Probe—Reference 7.8.2.1

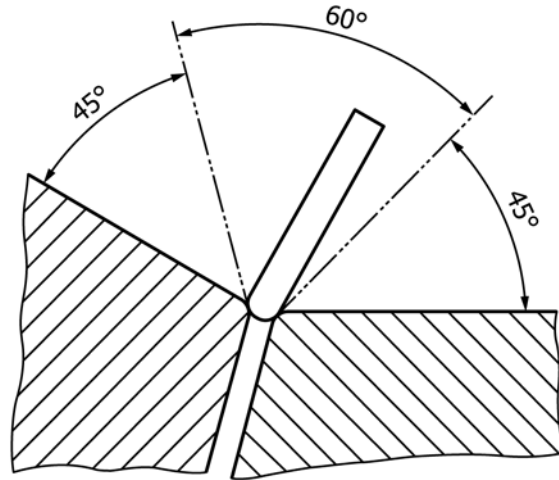

FIG. A1.18 Movement of Finger Probe—Reference 7.8.2.1

## APPENDIX

(Nonmandatory Information)

### X1. ADDITIONAL READING

#### X1.1. Other Documents

X1.1.1 *ASTM Standards*.<sup>8</sup>

D2240 Test Method for Rubber Property—Durometer Hardness

F698 Specification for Physical Information to be Provided for Amusement Rides and Devices (Withdrawn 2009)<sup>8</sup>

F846 Guide for Testing Performance of Amusement Rides and Devices (Withdrawn 2013)<sup>8</sup>

F853 Practice for Maintenance Procedures for Amusement Rides and Devices (Withdrawn 2014)<sup>8</sup>

F893 Guide for Auditing Amusement Rides and Devices (Withdrawn 2013)<sup>8</sup>

F963 Consumer Safety Specification for Toy Safety  
F1004 Consumer Safety Specification for Expansion Gates and Expandable Enclosures

F1159 Practice for Design of Amusement Rides and Devices that are Outside the Purview of Other F24 Design Standards

F1918 Safety Performance Specification for Soft Contained Play Equipment

X1.1.2 *ISO Standard*.<sup>9</sup>

ISO 22727 Graphical Symbols—Creation and Design of Public Information Symbols—Requirements

<sup>8</sup> For referenced ASTM standards, visit the ASTM website, [www.astm.org](http://www.astm.org), or contact ASTM Customer Service at [service@astm.org](mailto:service@astm.org). For *Annual Book of ASTM Standards* volume information, refer to the standard's Document Summary page on the ASTM website.

<sup>9</sup> Available from American National Standards Institute (ANSI), 25 W. 43rd St., 4th Floor, New York, NY 10036, <http://www.ansi.org>.



*ASTM International takes no position respecting the validity of any patent rights asserted in connection with any item mentioned in this standard. Users of this standard are expressly advised that determination of the validity of any such patent rights, and the risk of infringement of such rights, are entirely their own responsibility.*

*This standard is subject to revision at any time by the responsible technical committee and must be reviewed every five years and if not revised, either reapproved or withdrawn. Your comments are invited either for revision of this standard or for additional standards and should be addressed to ASTM International Headquarters. Your comments will receive careful consideration at a meeting of the responsible technical committee, which you may attend. If you feel that your comments have not received a fair hearing you should make your views known to the ASTM Committee on Standards, at the address shown below.*

*This standard is copyrighted by ASTM International, 100 Barr Harbor Drive, PO Box C700, West Conshohocken, PA 19428-2959, United States. Individual reprints (single or multiple copies) of this standard may be obtained by contacting ASTM at the above address or at 610-832-9585 (phone), 610-832-9555 (fax), or [service@astm.org](mailto:service@astm.org) (e-mail); or through the ASTM website ([www.astm.org](http://www.astm.org)). Permission rights to photocopy the standard may also be secured from the Copyright Clearance Center, 222 Rosewood Drive, Danvers, MA 01923, Tel: (978) 646-2600; <http://www.copyright.com/>*