



Standard Test Method for Surrogate Testing of Vehicle Impact Protective Devices at Low Speeds¹

This standard is issued under the fixed designation F3016/F3016M; the number immediately following the designation indicates the year of original adoption or, in the case of revision, the year of last revision. A number in parentheses indicates the year of last approval. A superscript epsilon (ϵ) indicates an editorial change since the last revision or reapproval.

INTRODUCTION

City and county governments are beginning to adopt legislation intended to reduce the increasing number of vehicle-into-building impacts. Typically, these ordinances are enforced as part of zoning laws, which require a protective device to be installed to protect pedestrians and storefront property where nose-in or head-in parking is present. For instance, in July 2012, The County of Miami Dade Florida adopted a zoning amendment requiring protective devices be installed to protect pedestrian traffic on sidewalks and inside storefronts for all new commercial construction. Examples of ways these protective devices might be deployed otherwise include the protection of patrons at bus stops; storefronts of commercial entities where parking or the direction of traffic flow are perpendicular to the building; restaurant patios bordering the street or on a sidewalk; and these protective devices could be used to protect propane tanks, gas pumps, and other hazardous materials to promote public safety.

As the demand for vehicle impact protection devices increases, the ability to evaluate whether each protective device performs as intended to protect the people, area, or asset is required. Guidelines have been developed previously to test vehicle protective devices by applying a static load at a particular location on the protective device. For instance, the State Fire Marshal Division of the Minnesota State Department of Public Safety has issued an “Aboveground Storage Tank Plan” that discusses how to install above ground storage tanks. Section 3.8.1 states if a physical barrier is to be used to protect the storage tank, it “shall be a minimum of 36 inches in height and shall resist a force of 12 000 pounds applied 36 inches above the adjacent ground surface.” While such static test methods are beneficial in certain instances, the performance of a protective device when impacted dynamically cannot be conclusively predicted using such a test method.

Test Methods have been developed previously that provide for a range of impact conditions, designations, and penetration performance ratings for vehicles traveling at high speeds. Test Method [F2656](#) provides for high speed impact speeds of 65, 80, and 100 km/h [40, 50, and 60 mph]. However, no ASTM test method has been formally developed to quantify the dynamic performance of a vehicle protective device at speeds of 50 km/h [30 mph] and lower.

1. Scope

1.1 This test method provides a range of impact speeds to be used with a 22 250-N [5000 lb] surrogate test vehicle. This test method establishes a range for penetration performance ratings. End users will be responsible for identifying the appropriate vehicle impact speed and penetration performance ratings in this test method to satisfy their specific needs.

1.1.1 In addition, end users may assign certification ratings for vehicle protective devices based on the test methodologies

described herein. Test parameters are standardized to arrive at a common vehicle weight, enhance test realism and replication, and produce uniform rating designations.

1.2 *Units*—The values stated in either SI units or inch-pound units are to be regarded separately as standard. The values stated in each system may not be exact equivalents; therefore, each system shall be used independently of the other. Combining values from the two systems may result in nonconformance with the standard.

1.3 *This standard does not purport to address all of the safety concerns, if any, associated with its use. It is the responsibility of the user of this standard to establish appropriate safety and health practices and determine the applicability of regulatory limitations prior to use.*

¹ This test method is under the jurisdiction of ASTM Committee [F12](#) on Security Systems and Equipment and is the direct responsibility of Subcommittee [F12.10](#) on Systems Products and Services.

Current edition approved Nov. 1, 2014. Published December 2014. DOI: 10.1520/F3016_F3016M-14.

2. Referenced Documents

2.1 ASTM Standards:²

C31/C31M Practice for Making and Curing Concrete Test Specimens in the Field

C39/C39M Test Method for Compressive Strength of Cylindrical Concrete Specimens

C136 Test Method for Sieve Analysis of Fine and Coarse Aggregates

D2487 Practice for Classification of Soils for Engineering Purposes (Unified Soil Classification System)

F2656 Test Method for Vehicle Crash Testing of Perimeter Barriers

2.2 AASHTO Standard:³

MASH Manual for Assessing and Safety Hardware

T099 Standard Method of Test for Moisture-Density Relations of Soils Using a 2.5-kg [5.5-lb] Rammer and a 305-mm [12-in.] Drop

2.3 ISO Standard:⁴

ISO/IEC 17025 General Requirements for the Competence of Testing and Calibration Laboratories

2.4 SAE Standards:⁵

J211–1 Instrumentation for Impact Test—Part 1: Electronic Instrumentation

J211–2 Instrumentation for Impact Test—Part 2: Photographic Instrumentation

3. Terminology

3.1 Definitions:

3.1.1 *accredited independent testing laboratory, n*—testing laboratory accredited to perform the referenced testing procedures by a nationally recognized accrediting agency in accordance with ISO/IEC 17025 and led by a test director.

3.1.1.1 *Discussion*—Accredited independent testing laboratories may have no financial interest in or otherwise be affiliated with companies or individuals for which they perform accreditation testing. Hereinafter, accredited independent testing laboratories are referred to as either accredited facilities or testing laboratories. Independent testing laboratories whose testing protocols follow this test method may also conduct tests, provided they are actively seeking ISO/IEC 17025.

3.1.2 *acceleration, v*—the change of velocity with respect to time by the sign convention established by SAE J211 Section 7.

3.1.3 *agency, n*—specifier, responsible party, or owner.

3.1.4 *bollard, n*—vertical posts or series of posts, usually steel, concrete, wood, or combinations of same used to channel

or restrict vehicular traffic, which includes fixed, removable, and operable/retractable posts.

3.1.5 *channel amplitude class, n*—numerically equal to the upper limit of the measurement range.

3.1.6 *continuous barrier, n*—any protective device that relies on a continuous foundation or a continuous structural element to resist penetration by vehicles.

3.1.7 *debris, n*—post-impact protective impact device and surrogate test vehicle components dispersed as a result of impact.

3.1.8 *ditch, n*—excavation into existing grade with varying cross sections such as “V” or “U” shaped.

3.1.9 *durometer, n*—a measure of the indentation hardness of a material.

3.1.10 *dynamic penetration distance, n*—during the crash event, the greater of the maximum dynamic displacement of any portion of the protective device into the protected area or maximum dynamic intrusion of the surrogate test vehicle into the protected area or maximum dynamic displacement of any portion of the protective device.

3.1.10.1 *Discussion*—See Fig. A1.1 for location of protected area and protective device reference location.

3.1.11 *final resting point, n*—distance from the pre-impact reference location on a protective device to the farthest portion of the protective device or surrogate test vehicle.

3.1.11.1 *Discussion*—Additionally, if the surrogate vehicle does not pass the reference location, the final resting location shall be a negative distance as measured from the location on the surrogate test vehicle that is closest to the reference location.

3.1.12 *impact location, n*—specific location on the protective device where the surrogate test vehicle will initially contact the protective device.

3.1.12.1 *Discussion*—The impact location is centered on the protective device for a bollard, concrete shape, or discrete device (bench, planter, and so forth). The impact location is at the mid-span of a fence, gate, post, and beam or upside down “U.” For a continuous wall, the impact location is at an expansion joint. If there is no expansion joint, then the continuous wall shall have an impact location at mid-span. If any other protective device is to be tested, the location of impact shall be determined as the consensus among the manufacturer, testing laboratory, and end user (when applicable) for the impact location. The impact location shall be chosen as a point which will exploit the weakest point of the system.

3.1.13 *penetration rating, n*—rating achieved by a protective device based on dynamic penetration distance.

3.1.14 *protected area, n*—area, as defined by the governing agency or end user, behind the furthest lateral point of the protective device as referenced by the data, shown in Fig. A1.1.

3.1.15 *protective device, n*—bollard, wall, fence, planter, gate, bench, or other structure that provides protection against a vehicle entering a protected area.

² For referenced ASTM standards, visit the ASTM website, www.astm.org, or contact ASTM Customer Service at service@astm.org. For *Annual Book of ASTM Standards* volume information, refer to the standard’s Document Summary page on the ASTM website.

³ Available from American Association of State Highway and Transportation Officials (AASHTO), 444 N. Capitol St., NW, Suite 249, Washington, DC 20001, <http://www.transportation.org>.

⁴ Available from International Organization for Standardization (ISO), 1, ch. de la Voie-Creuse, CP 56, CH-1211 Geneva 20, Switzerland, <http://www.iso.org>.

⁵ Available from SAE International (SAE), 400 Commonwealth Dr., Warrendale, PA 15096-0001, <http://www.sae.org>.

3.1.16 *rated ASTM protective device, n*—tested protective device that achieves a given penetration rating based on the surrogate test vehicle traveling perpendicular to the protective device at the defined impact location for that particular device.

3.1.17 *shallow mount platform, n*—plate, pad, or structural foundation resting on the surface or embedded no more than 305 mm [12 in.] below the surface to which one or more protective devices are rigidly fixed.

3.1.18 *supplier, n*—manufacturer, distributor, designer, or constructor of the protective device that is to be tested and can include contractors, engineers, and architects.

3.1.19 *surrogate test vehicle, n*—a 22 250-N [5000 lb] surrogate test vehicle that is designed to replicate a common vehicle type and weight. See **Annex A2** for required specifications for surrogate test vehicle.

3.1.19.1 *Discussion*—See **Figs. A2.1 and A2.2**.

3.1.20 *test director, n*—employee of the testing laboratory responsible for all aspects of a test.

3.2 Acronyms:

3.2.1 *AASHTO*—American Association of State Highway Transportation Officials.

3.2.2 *ISO*—International Organization for Standardization.

3.2.3 *MASH*—Manual for Assessing Safety Hardware.

3.2.4 *SAE*—Society of Automotive Engineers.

3.2.5 *SUV*—Sport Utility Vehicle.

3.3 Abbreviations:

3.3.1 *fps*—frames per second.

3.3.2 *ft*—feet.

3.3.3 *g*—measure of acceleration referenced to gravity.

3.3.4 *in.*—inches.

3.3.5 *km/h*—kilometres per hour.

3.3.6 *kPa*—kiloPascal.

3.3.7 *lb*—pounds.

3.3.8 *m*—metres.

3.3.9 *m/s*—metres per second.

3.3.10 *mph*—miles per hour.

3.3.11 *ms*—milliseconds.

3.3.12 *N*—newtons.

3.3.13 *psi*—pounds per square inch.

3.3.14 *s*—second.

4. Summary of Test Method

4.1 The set of complete fabrication drawings and specifications for a protective device that will be tested shall be submitted by the supplier to the testing laboratory at least 14 days before testing. These documents shall become part of the permanent test record.

4.2 Before testing, an approved surrogate test vehicle speed and penetration rating is selected by the supplier in coordination with the test director and other stakeholders. Additionally, if the protective device does not have an identified impact location as stated above, then the supplier, testing laboratory,

and user agency or end user (when applicable) shall come to a consensus and identify the impact location as stated in **3.1.12**.

4.3 There will be a minimum of one test conducted. The first test article shall be the as-built test article if not specified; test the proposed design in washed sand. If the foundation displaces 25 mm [1 in.] or less in any direction from the initial footing location, the system is considered rigid and no other testing is required. If the foundation displaces greater than 25 mm [1 in.] in any direction from the initial foundation location, a second test is required with the foundation encased in a concrete slab. For protective devices on shallow mount foundations, only a single test is required, provided the platform is set in accordance with supplier's instruction.

4.4 The test director shall determine the validity of the test and, if found valid, shall assign a speed and a penetration rating for the protective device.

5. Significance and Use

5.1 This test method provides a procedure to establish a penetration rating for vehicle protective devices subjected to low-speed vehicle impact. Knowing the penetration rating provides the end user with the ability to select an appropriate protective device for site-specific conditions.

5.2 The protective device penetration rating does not imply that a device will perform as rated in all site conditions, approach routes, and topography. Also, this test method requires that the specimen only be tested at a specific impact location and, therefore, not all locations of impact can be tested and validated for a penetration rating. Other impact locations may provide different penetration ratings.

6. Apparatus

6.1 **Appendix X1** provides recommendations on methods of data acquisition that are required by this test method. **Appendix X2** provides an example form that may be used for surrogate test vehicle parameters to be measured before testing.

6.2 Pre-test data acquisition shall document the as-built, untested protective device and surrogate test vehicle configuration. Documentation includes as-built specifications and fabrication drawings for the protective device, measurements, and photography. Survey locations for evaluation of any base slab, columns, bollards, protective device, or protective device support elements that may define deformation, translation, rotation, and uplift should be recorded in pre-test and post-test states.

6.3 During the test, surrogate test vehicle impact speed and impact angle shall be measured. Video documentation, with perpendicular (profile), overhead, and downstream aligned with the centerline of the protective device (on surrogate test vehicle) shall be provided. Oblique views are recommended. Photographic instrumentation specifications shall be in accordance with SAE Standard J211–2. Minimum high-speed film or video shall be 400 fps or greater. Determination of impact time equals 0 s shall be established by the use of a contact ribbon switch mounted to the front face of the protective device or surrogate test vehicle bumper triggering a strobe flash that

can be recorded on the video documentation for cross referencing between video sources. In addition, the maximum dynamic penetration of any portion of the protective device or the surrogate test vehicle shall be measured from the initial reference location. In [Fig. A1.1](#), the reference location is illustrated.

6.4 Surrogate test vehicle acceleration shall be measured beginning 500 ms before impact and ending after the vehicle has come to rest. The primary accelerometer shall be located within 305 mm [12 in.] of the x-axis, y-axis, and 50 mm [2 in.] of the z-axis of the center of gravity of the surrogate test vehicle and set to measure longitudinal and lateral acceleration. The secondary accelerometer shall be located within 305 mm [12 in.] directly above the rear axle and centered along the x-axis of the surrogate test vehicle and set to measure longitudinal and lateral acceleration. Electronic instrumentation specifications shall be in accordance with SAE Standard J211–1. Additionally, all accelerometers must have a minimum channel amplitude class of 75 g.

6.4.1 Collecting acceleration data 500 ms before impact provides data to determine the stability of the surrogate test vehicle before impact.

6.5 After the test, protective device deformation, movement of the protective device foundation, surrogate test vehicle penetration, and damage of both test article and surrogate test vehicle, if any, shall be documented with measurements, data recordings, and photography. See [6.2](#) for suggested data collection locations. Greatest displacement of any debris from the test article and any debris from the test article over 50 N [10 lb] shall be measured in a straight line from impact location. Measure the general extents of the debris field. Other parameters peculiar to a protective device may entail additional documentation. For instance, a gate may be shown to be operational after the collision, even though this is not a requirement of this test method.

7. Testing

7.1 *Impact Performance*—The impact speed that the protective device is to withstand shall be established by the supplier in consultation with the test director and others who might be involved. Actual impact speed shall be within the permissible speed range for the test to be deemed acceptable. During the test, the greater of the maximum dynamic intrusion of the surrogate test vehicle or the maximum dynamic displacement of any portion of the protective device into the protected area at the impact speed determines the dynamic penetration rating for that specific speed. Surrogate test vehicle dynamic penetration shall be referenced to the leading edge of the surrogate test vehicle. There are three nominal test speeds in this test method: 20, 35, and 50 km/h [10, 20 and 30 mph] ([Table 1](#)).

7.2 Test Site:

7.2.1 Tests shall be conducted at an accredited facility. These accredited facilities shall have adequate space to accelerate the surrogate test vehicle to the desired impact speed and have a 2-m [6.56-ft] minimum distance behind the protective device reference location, as shown in [Fig. A1.1](#) and in

TABLE 1 Impact Condition Designations

Surrogate Test Vehicle Weight, N [lb]	Nominal Minimum Test Speed, km/h [mph]	Permissible Speed Range, km/h [mph]	Impact Speed Rating
22 250 ± 490 [5000 ± 110]	20 [10]	19 – 33.9 [9 – 18.9]	S10
	35 [20]	34 – 47.4 [19 – 27.4]	S20
	50 [30]	47.5 – 52.5 [27.5 – 32.5]	S30

accordance with [Table 1](#). In general, the space in front of and behind the test article needs to be level and clear unless part of the test installation.

7.2.2 Tests shall be conducted on flat, level ground where the grade change is less than 2 %. Protective devices can then be installed on curbs/sidewalks if the impact side face of the protective device is installed within 0.41 m [1.35 ft] of the face of the curb/sidewalk. However, if the protective device’s impact side face is to be installed greater than 0.41 m [1.35 ft] away from the face of the curb/sidewalk, see [7.3](#).

7.2.3 For the first test, the test article will be embedded in washed sand. The washed sand will have a depth and width 1.5 times the foundation depth or 0.6 m [2 ft], whichever is greater up to a maximum of 1.8 m [6 ft] and extend 0.3 m [1 ft] below bottom of device. The washed sand shall be analyzed in accordance with Test Method [C136](#) and classified in accordance with Practice [D2487](#). The washed sand shall be classified as SP – poorly graded sand and be compacted to a density of not less than 90 % maximum dry density in accordance with AASHTO Method of Test T099.

7.2.4 If a second test is necessary, the test article foundation shall be installed in a concrete slab. The concrete slab shall be formed out of 25 000-kPa [3600-psi] concrete and tested in accordance with both Practice [C31/C31M](#) and Test Method [C39/C39M](#). For the foundation to be considered rigid, the embedded foundation shall be in excess of three times the weight of the surrogate test vehicle or 66 800 N [15 000 lb].

7.3 *Test Article*—The protective device shall be constructed in a manner representative of the proposed actual service installation and conform to the supplier specifications and fabrication drawings. Any deviations from fabrication, specification, or erection details shall be noted in the test report. For instance, when the test article is to be installed greater than 0.41 m [1.35 ft] away from the curb, it shall be tested as such.

7.4 *Surrogate Test Vehicle*—The surrogate test vehicle shall be 22 2500 ± 490 N [5000 ± 110 lb] consisting of an impactor nose with the impact height at 710 ± 30 mm [28 ± 1 in.]. [Table 2](#) provides the required dimensions and specifications for

TABLE 2 Surrogate Test Vehicle Properties

Property	Specification
Wheel Base	2540 ± 125 mm [100 ± 5 in.]
Track Width	1805 ± 50 mm [71 ± 2 in.]
Tire Size	225/75/R15
Tire Inflation Pressure (minimum)	450 kPa [65 psi]
Gross Static Weight	22 250 ± 490 N [5000 ± 110 lb]
Center of Gravity	710 ± 30 mm [28 ± 1 in.]

surrogate test vehicle properties.

7.4.1 The surrogate test vehicle is modeled after an American Association of State Highway and Transportation Officials (AASHTO) Manual for Assessing Safety and Hardware (MASH) 2270P Pickup Truck. This vehicle represents the 94th percentile in terms of vehicle weight for all passenger vehicles sold in 2002 and have similar weights and center of gravity as large SUV. The surrogate test vehicle stiffness represents a MASH 2270P test vehicle impacting a rigid 10 in. nominal diameter bollard at 48 km [30 mph]. A method shall be used to replicate the measured MASH 2270P test vehicle crush as the impactor nose displaces. The required stiffness rate is provided in **Table 3**. Common methods to replicate vehicle crush, while not exclusive, are the use of crushable aluminum honeycomb or linear-elastic springs. The impactor nose shall have zero stored energy before impact and no elastic rebound after the impact.

7.4.2 Ballasts shall be used to increase weight if needed. The vertical center of gravity shall be at 710 ± 30 mm [28 ± 1 in.]. Load applied by the surrogate test vehicle shall align through the center of gravity of the surrogate test vehicle. The lateral center of gravity shall be within 50 mm [2 in.] of the surrogate test vehicle geometric center. The impactor nose shall be built in accordance with provided fabrication drawings in **Annex A2**. The surrogate test vehicle shall have proper wheel alignment and steering according to the criteria set forth in **Table 4**.

7.5 Penetration Limitation:

7.5.1 A penetration rating can be given for each of the two tests in washed sand and a concrete slab. However, if the foundation's horizontal displacement at ground level is 25 mm [1 in.] or less when the protective device is tested in the washed sand, then the system is considered rigid and no other test is needed. Review **7.3** for article to be installed as service application.

7.5.2 *Penetration Ratings*—In **Table 5**, penetration ratings for the predetermined limits are assigned as P1, P2, and failure. The dynamic penetration distance shall be reported and assigned a penetration rating.

8. Preparation of Apparatus

8.1 Test Article:

8.1.1 Each device, assembly, or structure used in a protective device shall be identified and documented by fabrication drawings and specifications.

8.1.2 All proprietary information shall be clearly indicated in the documents. All such information provided to the test director shall be safeguarded and shall not be disclosed to unauthorized personnel.

TABLE 3 Impactor Nose Stiffness

	<0.5 m [<19 in.]	0.5 – 0.78 mm [19 – 31 in.]	>0.78 mm [>31 in.]
Rate	110 N/mm [620 lb/in.] ± 10 %	1425 N/mm [8125 lb/in.] ± 10 %	490 300 N [110 000 lb] ± 10 % (constant)

TABLE 4 Steering and Wheel Alignment Properties for Surrogate Test Vehicle

Property	Left Wheel	Right Wheel
Caster	(+) 3.0° – (+) 5.0°	(+) 3.0° – (+) 5.0°
Camber	Neutral	Neutral
Toe	(+) 1.5 – (+) 3.0 mm [(+) 1/16 – (+) 1/8 in.]	

TABLE 5 Penetration Ratings

Penetration Rating Designation	Dynamic Penetration Distance, m [ft]
P1	≤0.30 [<1]
P2	0.31 – 1.22 [1 – 4]
Failure	≥1.23 [≥4]

8.1.3 Each drawing shall include the protective device title/description, drawing number, and date and shall be submitted in legible and recognized electronic format. Such formats include, but are not limited to cine, avi, or tiff files. Each drawing shall identify the protective device in exact detail. Fabrication drawings shall show the arrangement, locations, and dimensions of all components.

8.1.4 Specifications for materials used, location and type of all welds, and size and spacing of all reinforcing bars shall be included in the documents.

8.1.5 Standard commercial materials used in construction shall conform to configuration and performance standards established for the material by appropriate industrial specifications and shall be cited in the specifications.

8.1.6 Nonstandard materials or devices used in configurations not otherwise controlled by recognized industrial or supplier specifications shall be accompanied by full-disclosure drawings and specifications.

8.1.7 *Test Article Installation*—All test articles shall be installed according to specification. The construction process shall be documented with photographs. When being installed for the first test, the protective device shall be constructed and then embedded in the washed sand to the specified depth it would be installed in the field. Similarly, for the second test, the protective device shall be constructed as specified and then embedded in a concrete slab to create a rigid environment.

9. Procedure

9.1 *Compliance*—Once a test article is committed to testing for the purpose of obtaining a rating, a report of all testing conducted on the device or assembly shall be developed by the test director of the test laboratory regardless of the test outcome. Test documentation indicating compliance with the surrogate test vehicle impact resistance requirements and test results may be submitted to other interested agencies or end users by the test laboratory of the tested system with the permission of the supplier.

9.2 *Pre-test Submissions*—The supplier shall provide a test plan consisting of fabrication drawings and specifications of the device, assembly, or structure to be tested; configuration disclosure documentation; and proposed impact conditions to the test director at least 14 days in advance of testing. The supplier may provide the same information to the technical representative of any other interested agency or end user.

9.3 Impact Condition:

9.3.1 The method of surrogate test vehicle guidance before impact is optional providing the guidance system or its components do not cause significant changes in the surrogate test vehicle dynamics before, during, and immediately after impact. The surrogate test vehicle may be pushed, towed, or self-powered to the specified speed. If pushed or towed, the prime mover and guidance system shall be disengaged a minimum of 3 m [10 ft] before impact.

9.3.2 The surrogate test vehicle shall approach and impact the test article at $90 \pm 1.5^\circ$. Surrogate test vehicle impact, if not specified in **Annex A1**, shall be centered on the most vulnerable section or part of the protective device as determined by the test director and any other interested user agency or end user (see impact location in Section 3). Actual impact location shall be within ± 100 mm [4.0 in.] horizontally and vertically of this target.

9.3.3 Actual surrogate test vehicle impact speed shall be within the permissible range shown in **Table 5** to receive the penetration rating for the intended nominal impact speed. Tests with an impact speed outside of this the acceptable range may still receive a penetration rating if the test director determines that the test is within the permissible impact speeds of another speed category and the test director concludes that the test was conducted in accordance with the rest of the specifications provided in this test method.

9.4 Evaluation of Performance Rating:

9.4.1 Measurement of any piece of the protective device or surrogate test vehicle that penetrates past the initial reference line on the protective device shall be recorded. See **3.1.10** for a description of dynamic penetration distance.

9.4.2 The penetration ratings designated in **Table 5** shall be applied to all test types at all three speed levels.

9.5 *Rating Assignment and Certification*—If the tests are conducted in accordance with this test method, the test protective device shall be assigned a rating based on speed and dynamic penetration distance for each test. For example, the device rating would be S10/P2 for a test with an impact speed of 20 km/h [10 mph] and dynamic penetration distance of 0.31 to 1.22 m [1 to 4 ft].

10. Report

10.1 The test report, prepared by the test director of an accredited facility, shall include, but not be limited to, the following sections:

10.1.1 *Identification*—Name, address, and contact data of testing organization, responsible personnel, test facility location, and test date.

10.1.2 *Protective Device Description*—Describe as-built test article, including photographs, fabrication drawings, material specifications, and reference to design revisions from any earlier tests. Describe special fabrication and installation procedures (such as heat treatment, weldments, bolt tension, galvanizing in critical stressed areas, concrete unconfined compression strength on day of test, and so forth) that may influence structural behavior. Include fabrication drawings and specifications for recommended design changes.

10.1.3 *Surrogate Test Vehicle Description*—Describe surrogate test vehicle as per **Fig. X2.1** in **Appendix X2**. Provide measurements and pictures.

10.1.4 *Test Procedure*—Describe the test facility and associated equipment, data acquisition systems, and procedures used in calibrating and processing data. Include all conditions applicable to protective device performance.

10.1.5 *Findings*—Use the format shown in **Table 6**. Include time-stamped video with before-and-after documentary coverage of the test article and surrogate test vehicle, high-speed data views of the impact (perpendicular (profile), overhead, and oblique (if obtained)), and title block for each identifying test and test conditions.

10.1.6 *Evaluation*—Discuss the dynamic performance of the test article (structural adequacy, vehicle trajectory, and penetration). Maximum extents of the debris field shall be documented. Provide conclusions regarding acceptability of dynamic performance and assign a rating.

11. Retest and Design Modifications

11.1 *Retesting*—Failure of any assembly or protective device to achieve the desired penetration rating when tested in

TABLE 6 Report Format

Item	Description	Format
Damage estimate	barrier length, elements, or components required to restore installation; rotation, translation, and uplift reported	text, drawings, or photos, or a combination thereof (same formats as above)
Debris field	maximum extents of post-test vehicle and test article components	text (MS Word) and photographs (jpeg, tiff, or bitmap)
Dynamic penetration rating	maximum dynamic deformation of test article as measured from high-speed video or film	test (MS Word)
Dynamic strain	strain gauge data from critical barrier/gate locations (when obtained)	plots (ordinate 100 microstrain greater than highest recorded; abscissa 100 ms) (Dplot or ASCII)
Final resting point	distance from the pre-impact, inside edge of a barrier to the defined vehicle location at final rest	test (MS Word)
Movie during test	sequence (four to eight frames minimum) during impact (perpendicular (profile), overhead, and oblique (if obtained))	video (VHS)/CD/photographs
Still photography	vehicle and barrier installation before and after test	photographs (jpeg, tiff, or bitmap)
Strain gauges	drawing showing strain gauge locations (when obtained)	drawing (PDF or MS Word)
Vehicle accelerations	lateral and longitudinal; filtered (SAE J211, Class 60 and 180)	plots (ordinate 10 g's greater than highest recorded; abscissa 300 ms) (Dplot or ASCII)
Speed at impact	speed of the test vehicle measured at a maximum of 4.6 m from location of impact	text (MS Word)

accordance with this test method does not preclude the modification and resubmission of that assembly design for retesting. Any retesting shall be conducted in accordance with all requirements in this test method.

11.2 Design Modifications:

11.2.1 All modified protective devices shall bear an addendum to the model number that clearly identifies it as a revised configuration differing from previous models and shall be provided by the supplier.

11.2.2 Once the desired penetration rating has been demonstrated, no design or material change shall be made unless retested.

12. Precision and Bias

12.1 *Precision and Bias*—No statement is made concerning either the precision or bias of this test method since the single test result merely states what penetration rating a protective device can receive for a given impact condition.

13. Keywords

13.1 barrier; bench; bollard; curb; fence; impact speed; low speed; pedestrian protection; penetration rating; protective device; shallow mount; surrogate test vehicle; wall

ANNEXES

(Mandatory Information)

A1. PROTECTIVE DEVICE REFERENCE LOCATIONS

A1.1 See **Fig. A1.1**.

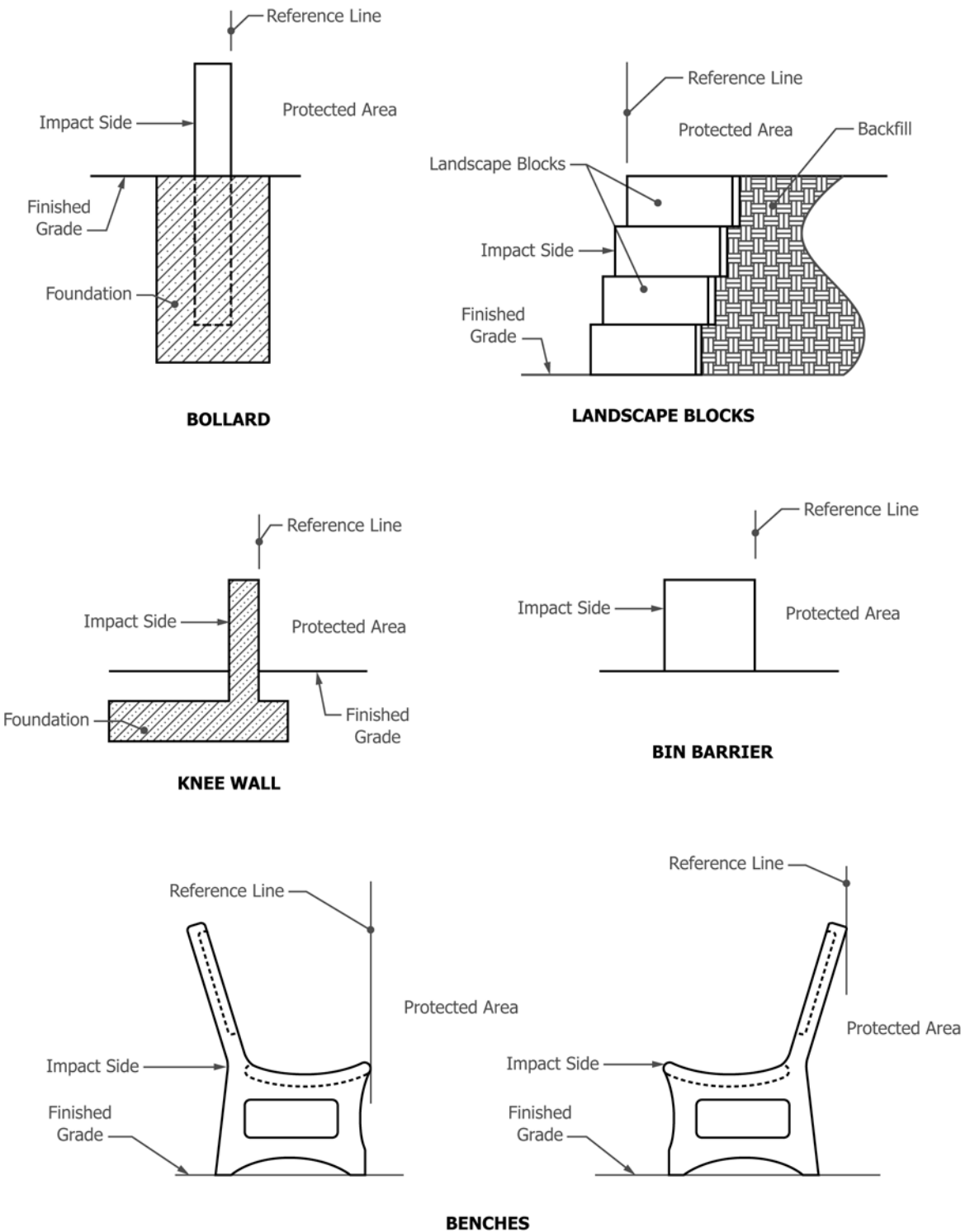

FIG. A1.1 Protective Devices Reference Locations

A2. SURROGATE TEST VEHICLE DIMENSIONS AND SPECIFICATIONS

A2.1 See Figs. A2.1 and A2.2.

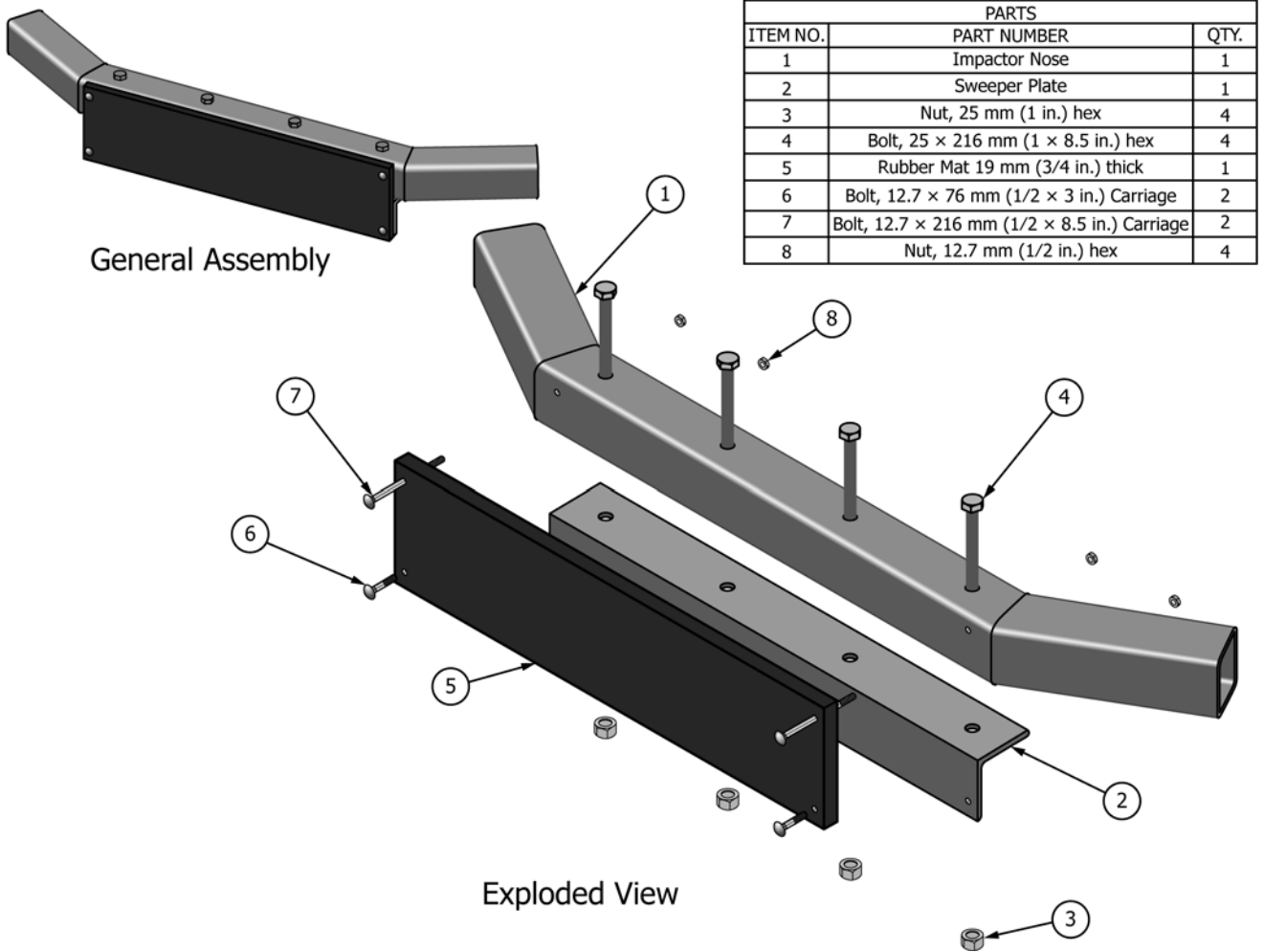
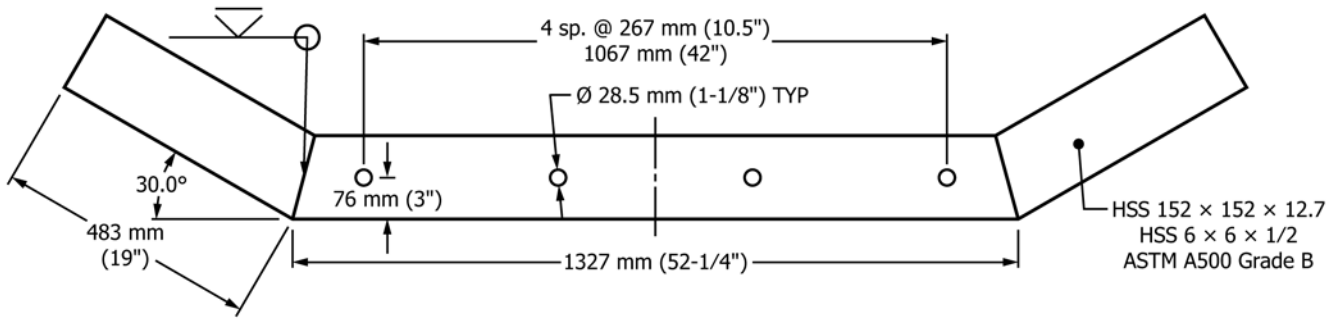

FIG. A2.1 Surrogate Test Vehicle Impactor Nose

1 IMPACTOR NOSE
Plan View



2 SWEEPER PLATE
Plan View

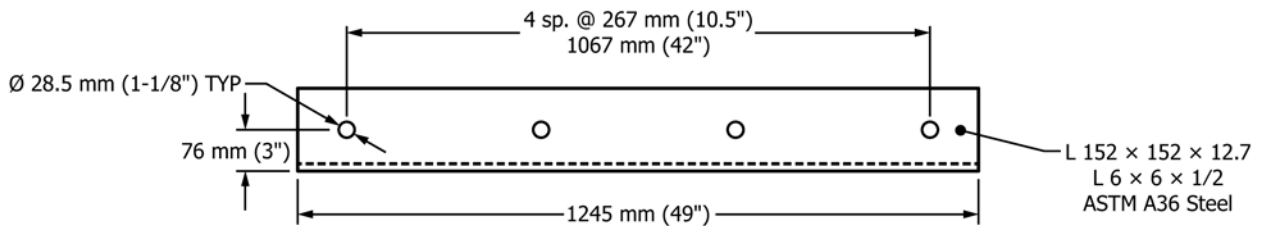

FIG. A2.2 Details for Surrogate Test Vehicle Impactor Nose

APPENDIXES

(Nonmandatory Information)

X1. DATA ACQUISITION METHODS

X1.1 See [Table X1.1](#) for data acquisition methods.

TABLE X1.1 Data Acquisition Methods

Phase	Parameter	Measurement Tolerances	Acceptable Techniques	Remarks
Pre-test	Test Article installation	±6 mm [0.25 in.]	General surveying equipment, photography	Post spacing, rail heights, alignment, orientation, and so forth are critical items. Survey locations for elevation of any base slab, columns, bollards, protective device, or protective device support elements that may define deformation, translation, rotation, and uplift should be recorded in pre-test and post-test states.
	Weight of surrogate test vehicle and onboard elements	±2 % of items but not more than ±880 N [198 lb]	commercial scales	Weight distribution of vehicle as tested.
	Geometry of surrogate test vehicle	±6 mm [0.236 in.]	common scales	See Appendix X2 for critical items.
	Protective device/surrogate test vehicle initial position	(not applicable)	Photography	Photos of protective device and surrogate test vehicle.
Test	Impact speed	±0.25 km/h (±0.07 m/s) [±1.86 mph (±2.72 ft/s)]	(a) overhead high-speed camera (b) perpendicular high-speed camera (c) speed trap	Minimum film speed of 400 fps. Speed measured during vehicle approach at a maximum 4.6 m from location of impact.
			(a) accelerometers designed for high g service	Lateral and longitudinal (and preferably vertical) accelerometers attached to a common mounting block and the block attached to the surrogate test vehicle structure on surrogate test vehicle centerline at center of surrogate test vehicle gross weight distribution (longitudinal). A second set of accelerometers is desired. Complete data system response from 0 to 500-Hz signal. Raw data recorded and maintained as permanent record. Data may be filtered for visual presentation.
	Vehicle accelerations	±1 g	(b) high-speed cameras (to be used three dimensional only as backup or secondary system as a result of uncertainty in data processing attributed to a double differentiation calculation).	Minimum film speed of 400 fps. Internal or external timing device: stationary references located in field of view of at least two cameras positioned 90° apart. Layout and coordinates of references, camera positions, and impact location should be reported. Two vehicle references are to be located on the top of the surrogate test vehicle, one position as close to the center of gravity as possible and the second 1.0 m [3.28 ft] to the rear. Instant of impact should be denoted by a flash unit placed in view of data camera. The instant of impact should also be recorded on magnetic tape.
Post-test	Impact angle	±1.5°	overhead high-speed cameras	Minimum film speed of 400 fps.
	Dynamic Penetration	±6 mm [0.236 in.]	(a) overhead high-speed camera (b) perpendicular high-speed camera	Minimum film speed of 400 fps. Dynamic penetration measured from the reference location on the outermost edge of the protective device in its original position to the furthest to the part of the surrogate test vehicle or protective device that moved the furthest towards the protective area. See Fig. A1.1 .
	Protective device permanent deformation/final position	6 mm [0.236 in.]	General surveying equipment	Greatest displacement of any debris measured from center of impact (linear distance) and greatest distance of any debris over 45 N [9.92 lb] (linear distance). Displacement of the foundation and protective device is to be determined.
	Protective device/surrogate test vehicle final position	(not applicable)	Photography	Photos of protective device and surrogate test vehicle.

X2. SURROGATE TEST VEHICLE WITH DIMENSIONS AND PROPERTIES TO BE MEASURED AND RECORDED

X2.1 See [Fig. X2.1](#) for surrogate test vehicle dimensions and properties to be measured and recorded.

Date: _____ Test No.: _____ Model: _____

Tire Inflation Pressure: _____ Tire Size: _____

Describe any damage to the surrogate test vehicle prior to test: _____

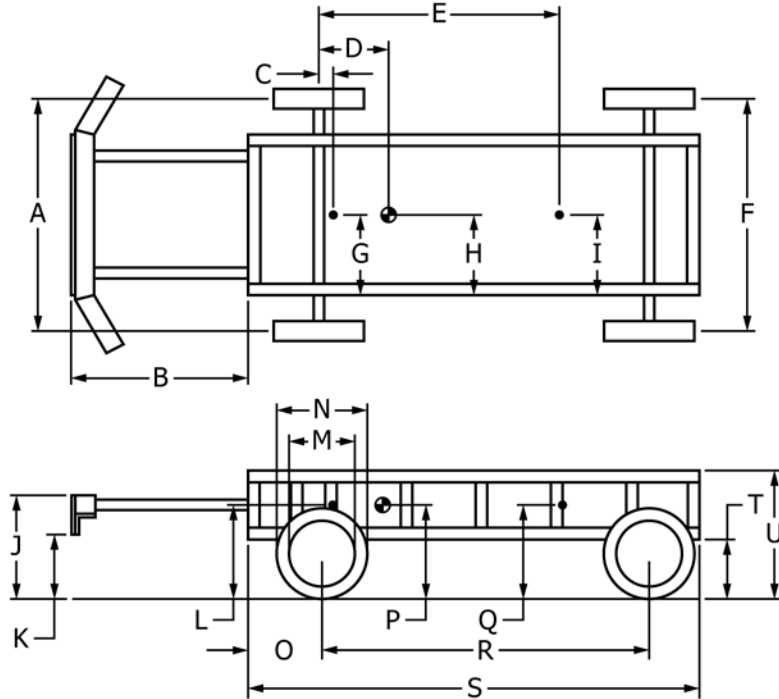

● Center of Gravity

• Accelerometer

Geometry: millimetre inches

A _____	F _____	K _____	P _____	U _____
B _____	G _____	L _____	Q _____	
C _____	H _____	M _____	R _____	
D _____	I _____	N _____	S _____	
E _____	J _____	O _____	T _____	

Weight Distribution: N lbs LF: _____ RF: _____ LR: _____ RR: _____

Weight:

N lbs	<u>Gross Static</u>
W_{front}	_____
W_{rear}	_____
W_{Total}	_____

FIG. X2.1 Vehicle Measurements for Surrogate Test Vehicle

ASTM International takes no position respecting the validity of any patent rights asserted in connection with any item mentioned in this standard. Users of this standard are expressly advised that determination of the validity of any such patent rights, and the risk of infringement of such rights, are entirely their own responsibility.

This standard is subject to revision at any time by the responsible technical committee and must be reviewed every five years and if not revised, either reapproved or withdrawn. Your comments are invited either for revision of this standard or for additional standards and should be addressed to ASTM International Headquarters. Your comments will receive careful consideration at a meeting of the responsible technical committee, which you may attend. If you feel that your comments have not received a fair hearing you should make your views known to the ASTM Committee on Standards, at the address shown below.

This standard is copyrighted by ASTM International, 100 Barr Harbor Drive, PO Box C700, West Conshohocken, PA 19428-2959, United States. Individual reprints (single or multiple copies) of this standard may be obtained by contacting ASTM at the above address or at 610-832-9585 (phone), 610-832-9555 (fax), or service@astm.org (e-mail); or through the ASTM website (www.astm.org). Permission rights to photocopy the standard may also be secured from the Copyright Clearance Center, 222 Rosewood Drive, Danvers, MA 01923, Tel: (978) 646-2600; <http://www.copyright.com/>