



# Standard Specification for 225/75R16C 116/114S M+S Radial Light Truck Standard Reference Test Tire<sup>1</sup>

This standard is issued under the fixed designation F2872; the number immediately following the designation indicates the year of original adoption or, in the case of revision, the year of last revision. A number in parentheses indicates the year of last reapproval. A superscript epsilon ( $\epsilon$ ) indicates an editorial change since the last revision or reapproval.

## 1. Scope

1.1 This specification covers the general requirements for the 225/75R16C 116/114S radial light truck (or European light duty vehicle) standard reference test tire. The tire covered by this specification is primarily for use as a reference tire for braking traction, snow traction, and wear performance evaluations, but may also be used for other evaluations, such as pavement roughness, noise, or other tests that require a reference tire.

1.1.1 Other standard reference test tires are also used for these purposes and are referenced in Section 2.

1.2 This specification provides a 16.0 rim diameter code standard tire design and construction, standard dimensions, and specifies the conditions of storage.

1.3 The values stated in SI units are to be regarded as standard. The values given in parentheses are mathematical conversions to inch-pound units that are provided for information only and are not considered standard.

1.4 *This standard does not purport to address all of the safety concerns, if any, associated with its use. It is the responsibility of the user of this standard to establish appropriate safety and health practices and determine the applicability of regulatory limitations prior to use.*

## 2. Referenced Documents

### 2.1 ASTM Standards:<sup>2</sup>

[D412 Test Methods for Vulcanized Rubber and Thermoplastic Elastomers—Tension](#)

[D3182 Practice for Rubber—Materials, Equipment, and Procedures for Mixing Standard Compounds and Preparing Standard Vulcanized Sheets](#)

[E867 Terminology Relating to Vehicle-Pavement Systems](#)

[E1136 Specification for P195/75R14 Radial Standard Reference Test Tire](#)

[F538 Terminology Relating to the Characteristics and Performance of Tires](#)

[F2493 Specification for P225/60R16 97S Radial Standard Reference Test Tire](#)

[F2870 Specification for 315/70R22.5 154/150L Radial Truck Standard Reference Test Tire](#)

[F2871 Specification for 245/70R19.5 136/134M Radial Truck Standard Reference Test Tire](#)

### 2.2 ISO Standards:<sup>3</sup>

[ISO 868 Plastics and ebonite – Determination of indentation hardness by means of a durometer \(Shore hardness\)](#)

[ISO 21509 Plastics and Ebonite – Verification of Shore durometers](#)

## 3. Terminology

### 3.1 Definitions:

3.1.1 For definitions of terms used in this specification, refer to Terminology [F538](#).

3.1.2 *pavement characteristic, n*—physical feature or property of a pavement surface such as type, roughness, texture, and skid resistance. **E867**

3.1.3 *pitch, n*—unit of tread pattern elements used in various combinations to obtain optimum noise levels. **F538**

3.1.4 *standard reference test tire, SRTT, n*—tire that is used as a control tire or surface-monitoring tire (for example, Specifications [E1136](#), [F2493](#), [F2870](#), [F2871](#), and [F2872](#) tires). **F538**

## 4. Design and Construction

4.1 The 225/75R16C 116/114S standard reference test tire shall feature the steel-belted radial technology, see [Fig. 1](#) and [Fig. 2](#), with technology as described in Sections 5 – 7.

4.2 The tire shall be designed to conform to the European Tyre and Rim Technical Organisation (ETRTO) dimensions

<sup>1</sup> This specification is under the jurisdiction of ASTM Committee [F09](#) on Tires and is the direct responsibility of Subcommittee [F09.20](#) on Vehicular Testing.

Current edition approved Nov. 1, 2016. Published November 2016. Originally approved in 2011. Last previous edition approved in 2011 as F2872 – 11. DOI: 10.1520/F2872-16.

<sup>2</sup> For referenced ASTM standards, visit the ASTM website, [www.astm.org](http://www.astm.org), or contact ASTM Customer Service at [service@astm.org](mailto:service@astm.org). For *Annual Book of ASTM Standards* volume information, refer to the standard's Document Summary page on the ASTM website.

<sup>3</sup> Available from International Organization for Standardization (ISO), ISO Central Secretariat, BIBC II, Chemin de Blandonnet 8, CP 401, 1214 Vernier, Geneva, Switzerland, <http://www.iso.org>.



FIG. 1 Front View of the 225/75R16C 116/114S Radial Light Truck Standard Reference Test Tire



FIG. 2 Side View of the 225/75R16C 116/114S Radial Light Truck Standard Reference Test Tire

and tolerances for cross section and overall diameter found in the current ETRTO Standards Manual.<sup>4</sup>

4.3 The tire used for this specification is produced by Manufacture Francaise des Pneumatiques Michelin.<sup>5</sup> The tire is stamped on the sidewall with the words: “Standard Reference Test Tire” and “F2872”.

**5. Materials and Manufacture**

5.1 The individual standard reference test tires shall conform to the manufacturer’s design standards.

5.2 Tread compound, fabric processing, and all the steps in tire manufacturing shall be controlled to ensure minimum variability between tires.

5.3 The standard reference test tire shall be as originally molded without any tread grinding or repairs.

<sup>4</sup> Available from the European Tyre and Rim Technical Organisation 78/80, rue Defacqz – B-1060 Brussels Belgium.

<sup>5</sup> The sole source of supply of the apparatus known to the committee at this time is Manufacture Francaise des Pneumatiques Michelin CERL Ladoux, 23 place des Carnes Dechaux, 6304 Clermont-Ferrand Cedex 09, France (attn. F43 Magasin – specify 225/75R16C 116/114S Michelin light truck SRTT). If you are aware of alternative suppliers, please provide this information to ASTM International Headquarters. Your comments will receive careful consideration at a meeting of the responsible technical committee,<sup>1</sup> which you may attend.

5.4 Since the formulation for tread compounds are proprietary, they shall be controlled by means of their physical properties given in Table 1.

5.5 Dimensions, weights, and permissible variations are given in Section 7.

5.6 The tire shall be of the following construction:

5.6.1 Two-ply sidewall construction (polyester).

5.6.2 A five-ply tread construction (two-ply polyester and three steel belts).

5.6.3 Black sidewall.

**6. Physical Properties**

6.1 The physical properties of the tread compound are listed in Table 1.

**7. Dimensions, Weights, and Permissible Variations**

7.1 Details of dimensions are listed as follows and are shown in Fig. 3. When tolerances are not specified, tire dimensions are subject to manufacturer’s normal tolerances.

7.2 *Inflated Dimensions and Cured Cord Angles (at 475 kPa (69 psi)):*

7.2.1 The tread width shall be 175.6 mm (6.91 in.), and the cross-sectional tread radius shall be 700 ± 50.8 mm (27.56 ± 2.0 in.).

7.2.2 The tread radius is measured using a reference radius template as shown in Fig. 4.

7.2.3 The tire shall have an overall section width of 223 mm (8.78 in.), and an outside diameter of 750.9 mm (29.56 in.) when mounted on a measuring rim (16 by 6.00 rim).

7.2.4 The cured cord angles shall be 90 ± 2° for the carcass and 22 ± 2° for the 3 belts.

7.3 *Ribs*—The tire shall have four ribs.

7.4 *Grooves*—The tire shall have three circumferential grooves having a minimum tread depth of 8.6 mm (0.339 in.).

7.5 *Tread Design:*

7.5.1 *Groove (Void) Area Fraction*—30 % in surface, 22.5 % in volume.

7.5.2 *Number of Pitches*—72.

7.5.3 *Footprint Size*—168.1 mm wide by 188.4 mm long (6.62 by 7.42 in.) at 1250 kg (2756 lb) at 475 kPa (69 psi).

7.6 *Tread Wear Indicators*—The tire shall have indicators in each groove, laterally across the tread width, in at least six locations spaced uniformly around the tire circumference. The height of the wear indicators in the grooves shall be 1.6 mm (0.0625 in.), – 0.00 mm, + 0.60 mm.

NOTE 1—Tread depth is not to be measured at these wear indicators.

**TABLE 1 Physical Properties of Tread Compound**

Tensile sheet cure, min at 160°C (320°F)	15.0 min
Stress at 300 % elongation, Mpa (psi)	11.0 ± 2.0 MPa (1595 ± 290 psi)
Tensile strength, min MPa (psi)	15.5 MPa (2250 psi) min
Elongation, min %	450 % min
Durometer hardness <sup>A</sup>	64 ± 2 Type A

<sup>A</sup> Measured on tire tread.

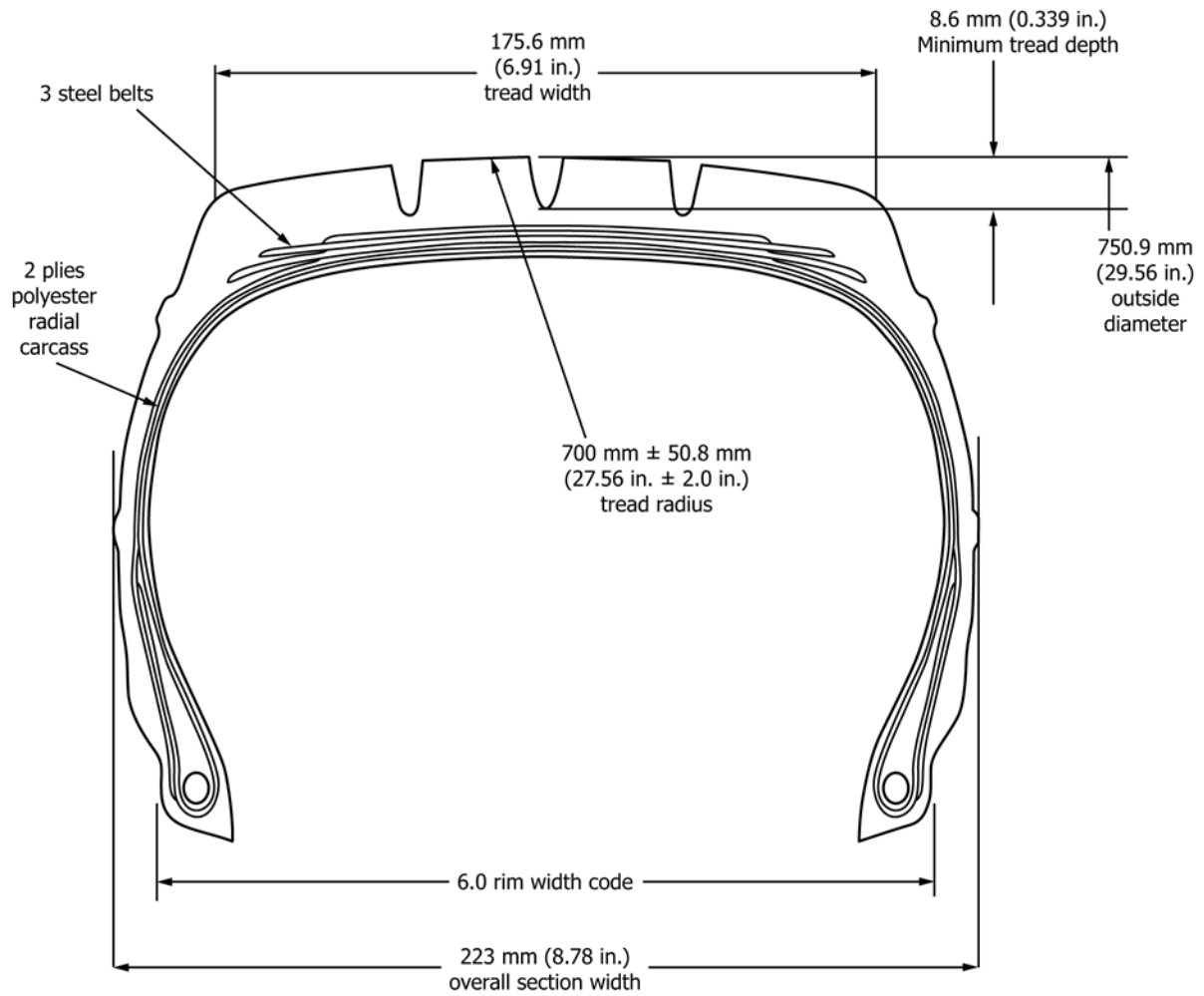

FIG. 3 Tire Cross Section – 225/75R16C 116/114S M+S Radial Light Truck



FIG. 4 Measuring a Tread Radius using a Reference Radius Template

## 8. Workmanship

8.1 Tires shall be free of defects in workmanship and material.

## 9. Test Methods

9.1 Preparation of tensile sheet cure shall be in accordance with Practice [D3182](#).

9.2 Stress at 300 % elongation shall be in accordance with Test Methods **D412**.

9.3 Tensile strength shall be in accordance with Test Methods **D412**.

9.4 Elongation shall be in accordance with Test Methods **D412**.

9.5 Tire tread hardness shall be in accordance with ISO 21509 and ISO 868 in addition to the following:

9.5.1 Use a Type A durometer that has the center of the presser foot at a minimum of 6.0 mm (0.24 in.) from any edge of the foot.

9.5.2 Check the durometer operation and the state of calibration of the durometer with the rubber reference block(s) or do the calibration of the durometer before and after the measurement of the SRTT.

9.5.3 Condition the tire and the durometer to an equilibrium of  $23 \pm 2^\circ\text{C}$  ( $73.4 \pm 3.6^\circ\text{F}$ ) before determining the tread hardness.

9.5.4 Determine the tire tread hardness by averaging at least four readings. Take these readings in the center of each rib, excluding the center rib. It is recommended that additional sets of readings be taken around the tread circumference.

9.5.5 Apply the presser foot to the tire tread, as rapidly as possible without shock, keeping the foot parallel to the tread surface. Apply just enough pressure to obtain firm contact between the presser foot and the tread surface. Read the durometer scale as soon as a stabilized value is obtained (see durometer manufacturer recommendations) after the presser foot has made contact with the tread, but after the initial maximum transient needle deflection that may occur immediately after contact is made.

## 10. Certification

10.1 Upon request, the manufacturer shall furnish to the purchaser certification that the test tire meets this specification.

10.2 All tires under certification shall be subject to the manufacturer's normal variation.

## 11. Storage and Preservation

11.1 The tires shall be stored under constant relative humidity conditions at a temperature not to exceed  $21^\circ\text{C}$  ( $70^\circ\text{F}$ ) and above freezing. The ozone level in the storage area shall not exceed 5 parts/ $10^8$  (or 5 mPa partial pressure), and no tires shall be stored within 9.1 m (30 ft) of electrical motors or other ozone-generating equipment. Storage of the tires shall be in subdued light, with the tires stacked unbundled, no more than eight tires high on a pallet.

## 12. Recommendations for Tire Use and Operational Requirements

12.1 It is recommended that the tire be used as a reference for braking traction, snow traction, and wear performance evaluations, and for other evaluations where a standard reference test tire is determined to be required.

12.2 The tire shall be mounted on an ETRTO measuring rim width code of 6.00 (for example, 16 by 6.00 J rim).

12.3 When irregular wear or damage results from tests, or when wear influences the test results, the use of the tire shall be discontinued.

12.4 Test results, such as measured friction force, may be influenced by tire tread depth or tread hardness or both. The magnitude of this dependence is a function of the water depth, pavement characteristics, test speed, tire aging effects, and break-in.

## 13. Keywords

13.1 braking; F09; light truck; SRTT; standard reference test tire; tire pavement friction; wet braking

## APPENDIX

### (Nonmandatory Information)

#### X1. RATIONALE

X1.1 This specification covers the general requirements for the 225/75R16C (LT) light truck radial standard reference test tire. The tire covered by this specification is primarily for use as a reference tire for braking traction, snow traction, and wear performance evaluations, but may also be used for other evaluations such as pavement roughness, noise, or other tests that require a reference tire.

X1.2 International standards and regulatory initiatives on wet grip braking performance for commercial vehicle tires (or as known in Europe, Class C2 and C3 tires) have required the development of this commercial vehicle standard reference test tire. The use of the standard reference test tire is necessary to limit the variability of the testing method procedures.

*ASTM International takes no position respecting the validity of any patent rights asserted in connection with any item mentioned in this standard. Users of this standard are expressly advised that determination of the validity of any such patent rights, and the risk of infringement of such rights, are entirely their own responsibility.*

*This standard is subject to revision at any time by the responsible technical committee and must be reviewed every five years and if not revised, either reapproved or withdrawn. Your comments are invited either for revision of this standard or for additional standards and should be addressed to ASTM International Headquarters. Your comments will receive careful consideration at a meeting of the responsible technical committee, which you may attend. If you feel that your comments have not received a fair hearing you should make your views known to the ASTM Committee on Standards, at the address shown below.*

*This standard is copyrighted by ASTM International, 100 Barr Harbor Drive, PO Box C700, West Conshohocken, PA 19428-2959, United States. Individual reprints (single or multiple copies) of this standard may be obtained by contacting ASTM at the above address or at 610-832-9585 (phone), 610-832-9555 (fax), or [service@astm.org](mailto:service@astm.org) (e-mail); or through the ASTM website ([www.astm.org](http://www.astm.org)). Permission rights to photocopy the standard may also be secured from the Copyright Clearance Center, 222 Rosewood Drive, Danvers, MA 01923, Tel: (978) 646-2600; <http://www.copyright.com/>*