



Standard Test Method for Assessing Carpet Cleaning Effectiveness in Terms of Visual Appearance Change When Cleaned with a Wet Extraction Cleaning System¹

This standard is issued under the fixed designation F2828; the number immediately following the designation indicates the year of original adoption or, in the case of revision, the year of last revision. A number in parentheses indicates the year of last reapproval. A superscript epsilon (ϵ) indicates an editorial change since the last revision or reapproval.

1. Scope

1.1 This test method provides only a laboratory test for visually determining the relative carpet cleaning effectiveness of a wet extraction cleaning system when tested under standard conditions.

1.2 This test method is applicable to types of upright, canister, and combination wet extraction cleaners and their recommended chemical cleaning formulas intended for cleaning carpets as a primary or secondary function. This test method excludes pre-spray systems or pre-spray treatments.

1.3 This test method is not applicable to upholstery cleaning or bare floor cleaning.

1.4 This test method applies only to the cleaning of embedded soil from carpet, not the removal of surface litter and debris.

1.5 This method does not directly quantify the amount of soil removed but is visually assessed by employing colorimetric instrumentation.

1.6 *Units*—The values stated in either SI units or inch-pound units are to be regarded separately as standard. The values stated in each system may not be exact equivalents; therefore, each system shall be used independently of the other. Combining values from the two systems may result in non-conformance with the standard.

1.7 *This standard does not purport to address all of the safety concerns, if any, associated with its use. It is the responsibility of the user of this standard to establish appropriate safety and health practices and determine the applicability of regulatory limitations prior to use.*

¹ This test method is under the jurisdiction of ASTM Committee F11 on Vacuum Cleaners and is the direct responsibility of Subcommittee F11.35 on Extractor Cleaners.

Current edition approved July 1, 2012. Published August 2012. DOI: 10.1520/F2828-12.

2. Referenced Documents

2.1 ASTM Standards:²

D6540 Test Method for Accelerated Soiling of Pile Yarn Floor Covering

E177 Practice for Use of the Terms Precision and Bias in ASTM Test Methods

E691 Practice for Conducting an Interlaboratory Study to Determine the Precision of a Test Method

F608 Test Method for Evaluation of Carpet Embedded Dirt Removal Effectiveness of Household/Commercial Vacuum Cleaners

F655 Specification for Test Carpets and Pads for Vacuum Cleaner Testing

3. Terminology

3.1 Definitions:

3.1.1 *cleaning effectiveness, wet, n*—the potential of a wet extractor cleaner to restore the appearance of a soiled carpet.

3.1.2 *cleaning system, n*—wet extraction appliance coupled with its included or recommended chemical cleaning formula.

3.1.3 *model, n*—the designation of a group of wet extraction cleaners having identical mechanical and electrical construction with only cosmetic or nonfunctional differences.

3.1.4 *population, n*—the total of all units of a particular model wet extraction cleaner being tested.

3.1.5 *sample, n*—a group of extraction cleaners taken from a large collection of extraction cleaners of one particular model which serves to provide information that may be used as a basis for making a decision concerning the larger collection.

3.1.6 *test run, n*—the definitive procedure that produces a singular measured result.

3.1.7 *unit, n*—a single wet extraction cleaner of the model being tested.

² For referenced ASTM standards, visit the ASTM website, www.astm.org, or contact ASTM Customer Service at service@astm.org. For *Annual Book of ASTM Standards* volume information, refer to the standard's Document Summary page on the ASTM website.

3.1.8 *wet stroke, n*—a single pass across the test carpet in one direction with the application of the cleaning solution.

3.1.9 *dry stroke, n*—a single pass across the test carpet in one direction without the application of any cleaning solution.

3.1.10 *Delta-E (ΔE), n*—a single number representing the distance in color space between two colors. Delta-E is derived mathematically and is used in colorimetry to evaluate the extent of color differences and change.

4. Significance and Use

4.1 This test method will provide an indication of the effectiveness of the cleaning system at restoring the appearance of an artificially soiled carpet by wet extraction cleaning. The cleaning effectiveness in the laboratory test may not be the same as in home cleaning due to variations in the homes, carpets, soils, and other factors.

4.2 In order to provide a uniform basis for measuring the performance described in section 1.1, standardized test carpet, test pad, and test soil are employed in this procedure.

5. Apparatus

5.1 *Weighing Scale* (for weighing test materials and carpets)—Accurate to 0.01 g (0.00035 oz) and having a weighing capacity of at least 2.0 kg (4.4 lb).

5.2 *Stroke Speed Regulator(s)*—LED two way timer bar(s) or other type of equipment capable of establishing the specified rate of movement of the agitator vacuum, test cleaner, and carpet rake.

5.3 *Voltmeter*—To measure the input voltage to the cleaner, to provide measurements accurate to within ± 1 %.

5.4 *Voltage-Regulator System*—To control input voltage to the cleaner. The regulator must be capable of maintaining the wet extraction cleaner's rated voltage ± 1 % and rated frequency having a waveform that is essentially sinusoidal with 3 % max harmonic distortion for the duration of the test.

5.5 *Soiling Apparatus:*

5.5.1 *Carpet and Pellet Soiling Cylinder*—Able to be turned freely on a ball mill roller. See [Appendix X1](#).

5.5.2 *Driving System*—Cradles the carpet and pellet soiling cylinder on rollers and keeps the axis of the cylinder level, rotates at 0.58 r/s (35 ± 2 rpm).

5.6 *Color Measurement Equipment*—Colorimeter capable of measuring the color of pile yarn floor covering and expressing the results in L^* , a^* , b^* . The device shall utilize a weight and glass plate to compress the instrument into the fibers to reduce variability inherent in the measurement of textiles with pile such as carpet. The recommended pressure of the glass plate on the carpet surface is to be 70.0 ± 7.0 g/cm² (1.0 ± 0.1 psi).

NOTE 1—All necessary adjustments to the color measurement equipment for using a glass plate must be made prior to taking readings. See the manufacturer's instructions for the specific equipment being used.

5.7 *Colorimeter Weight*—Weight to be added to the colorimeter to ensure that the compressing force defined in section 5.6 is achieved. See [Fig. 1](#). The amount of weight required will

vary depending on the total weight and the measurement head dimensions of the colorimeter employed.

5.8 *Pyrometer*—Or other temperature measurement device capable of measurements up to at least $55 \pm 0.1^\circ\text{C}$ ($131 \pm 0.1^\circ\text{F}$).

5.9 *Carpet Color Measurement Template*—To be the same size as the test carpet with 10 holes of the same dimensions as the measurement head of the color measuring device. See templates in [Appendix X5](#).

5.10 *Vacuum Cleaner(s)*—With a rotating brush having a range of cleaning performance on ASTM Plush carpet between 35 and 45 % when evaluated per the Test Method [F608](#) procedure. Multiple units of identical construction are required for each of the carpet conditions (VIRGIN CARPET, SOILED CARPET, CLEANED CARPET) to avoid cross-contamination.

5.11 *Carpet Support Template*—A template which can receive the test carpet with no gaps or overlapping of material. The material shall be of similar construction to the test carpet and mounted on the carpet pad.

5.12 *Weighted Carpet Grooming Rake*—An 18-in. wide Grandi Groom carpet rake with 3 lb weight added.³ See [Fig. 2](#).

6. Materials

6.1 *Test Carpet*—Cut pile nylon carpet. See [Appendix X2](#).

6.2 *Test Padding*—Standardized carpet pad per Specification [F655](#).

6.3 *Standard Soiling Compound*—AATCC 123 synthetic soiling formula.⁴

6.4 *Polymer Pellets*—Polyamide polymer pellets per Test Method [D6540](#). See example of pellet material in [Appendix X3](#).

6.5 *Chrome Alloy Steel Balls*— 9.5 ± 0.02 mm (0.374 ± 0.01 in.) diameter.

7. Sampling

7.1 A minimum of three units of the same model wet extraction cleaner selected at random in accordance with good statistical practice shall constitute the population sample.

7.2 A minimum of six (6) carpet panels shall be tested per test for each unit. Three (3) panels to be cleaned in the direction of the lay and three (3) to be cleaned AGAINST the lay. See [Fig. 4](#).

8. Conditioning

8.1 *Test Room*—Maintain the test room in which all conditioning and extractor cleaner testing is performed at $21 \pm 3^\circ\text{C}$ ($70 \pm 5^\circ\text{F}$) and 45 to 55 % relative humidity.

8.2 All components involved in the test shall remain and be exposed in the controlled environment for at least 16 h prior to the start of the test.

³ Groom Industries AB24 available at: Groom Industries – Groom Industries, 4282 South 590 West, Salt Lake City, UT 84123, (800) 397-3759

⁴ The prepared soil is available from SDL Atlas USA, 3934 Airway Drive, Rock Hill, SC 29732, (803) 329-2110. The soil identification is Catalog # TA2M/9.

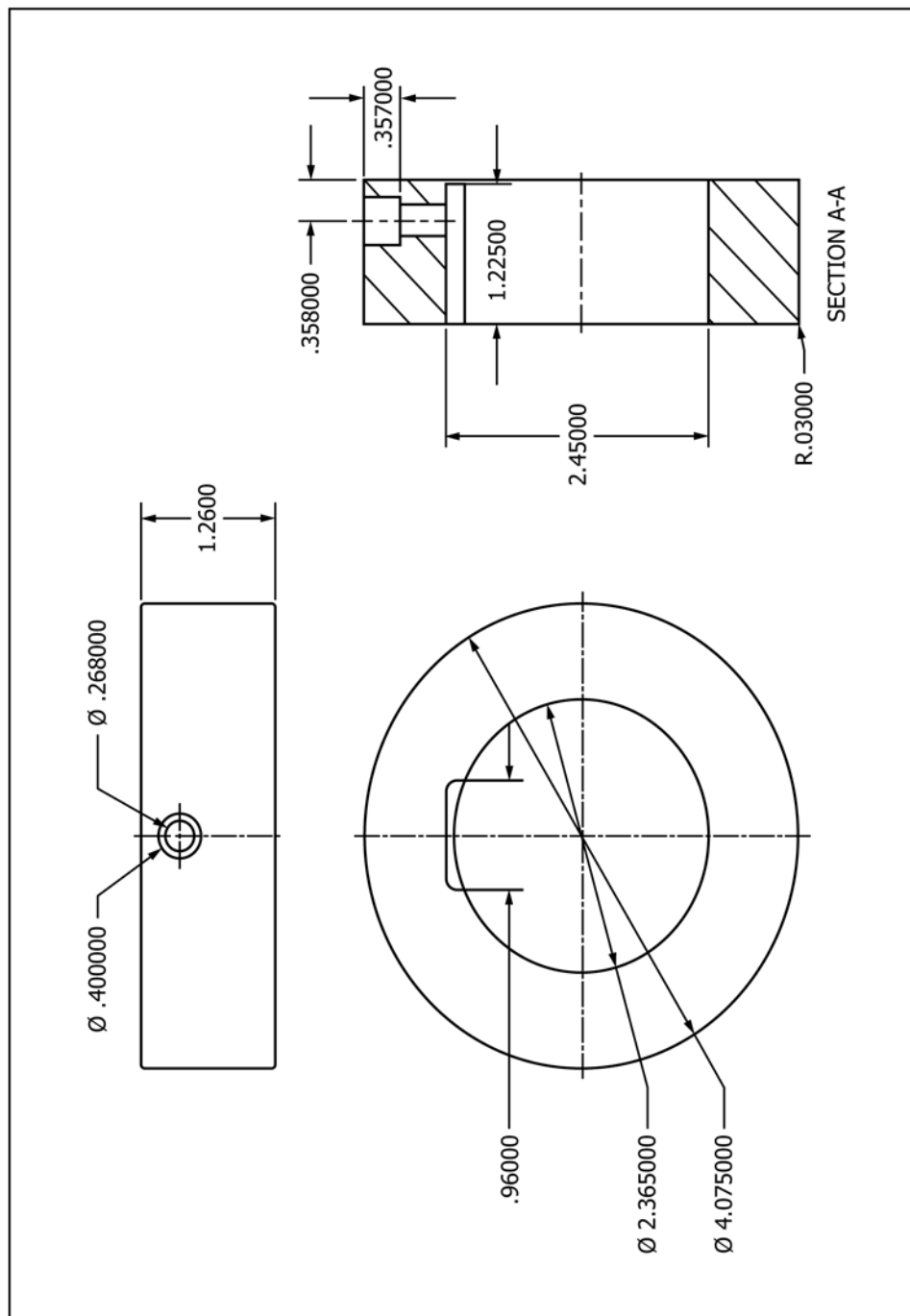

FIG. 1 Colorimeter Weight

NOTE 2—Materials, such as soil, should be stored according to the manufacturer’s instructions and are not required to be exposed to the test room conditions.

9. Procedures

9.1 Polyamide Pellet Preparation:

9.1.1 Place 1000.0 ± 1.0 g (35.3 ± 0.04 oz) of the polyamide polymer pellets into the pellet soiling cylinder.

9.1.2 Add 3.0 ± 0.1 g (0.106 ± 0.004 oz) of the AATCC Standard Soil to the soiling cylinder for each 1000 g (35.3 oz) of polyamide polymer pellets to be soiled.

9.1.3 Secure the lid and place the soiling cylinder on the driving system. Rotate for 10 min at 0.58 r/s (35 rpm).

9.1.4 Reverse direction and continue for an additional 10 min, for a total of 20 min to ensure a homogenous mixture of the soil and polyamide polymer pellets.

9.1.5 Only prepare enough pellets for testing to be conducted within a given work day.

NOTE 3—It is recommended to only prepare enough pellets for testing within a given work day. Any remaining pellets not used within 14 days for testing should be discarded.

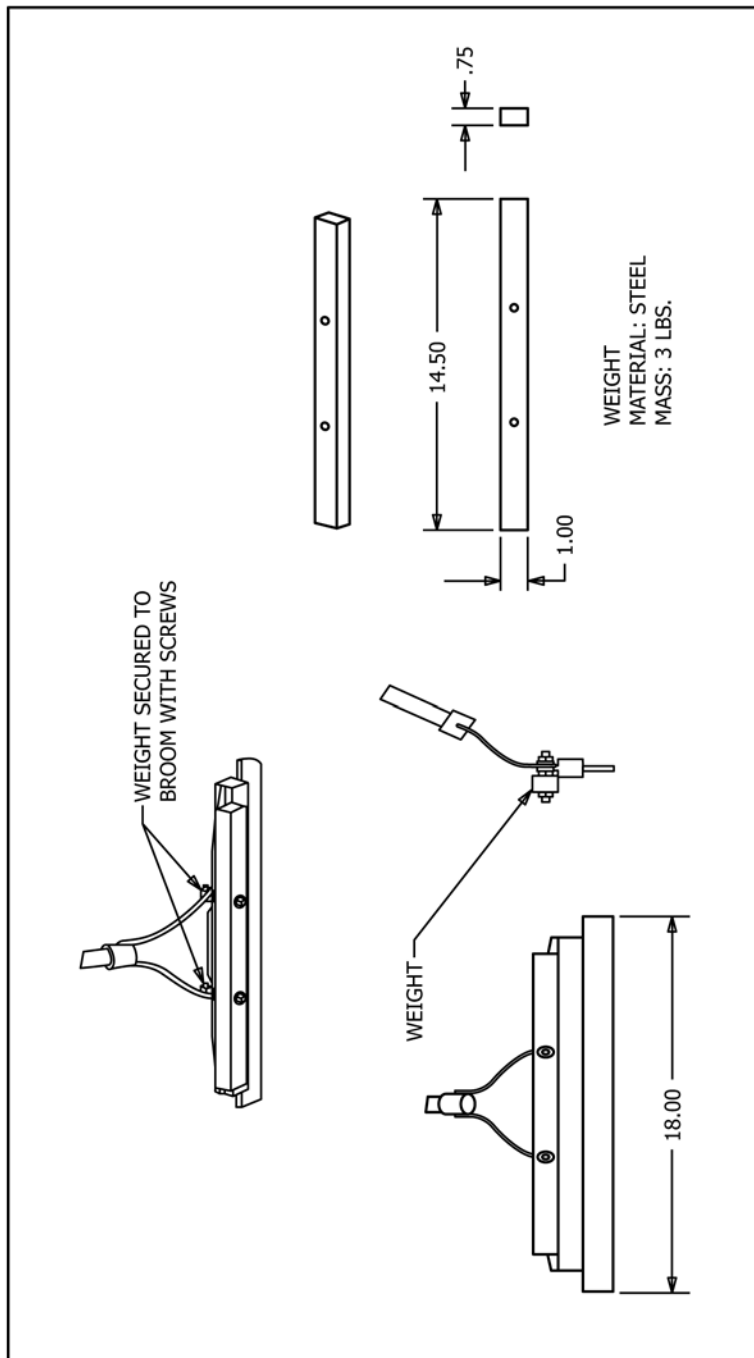

FIG. 2 Grandi Groom Carpet Rake

9.2 Test Carpet Preparation:

9.2.1 Cut the carpet specimen into carpet panels 45.7 cm (18 in.) wide and 91.4 cm (36 in.) long, with the long dimension in the direction of carpet lay. The lay of the carpet must be oriented to result in six (6) panels for each test. Three (3) panels with the “top” marked such that they will be cleaned WITH the lay and the other three (3) panels marked with the “top” such that they will be cleaned AGAINST the lay as shown in Fig. 4. The carpet panels should be numbered for reference.

9.2.2 Prepare the carpet panels for testing by vacuuming each to remove loose fibers with the VIRGIN CARPET rotating agitator vacuum cleaner for 16 strokes at 0.55 m/s (1.8 ft/s). Eight strokes on each side of the carpet starting on the right side and indexing after the eighth stroke to the opposite side. Allowance should be made for the belt guard so that the entire area is cleaned with agitation. The first forward stroke should be AGAINST the lay of the carpet in all cases.

9.2.3 Using the procedure described in 9.3, evaluate the carpet to determine the initial, virgin readings.

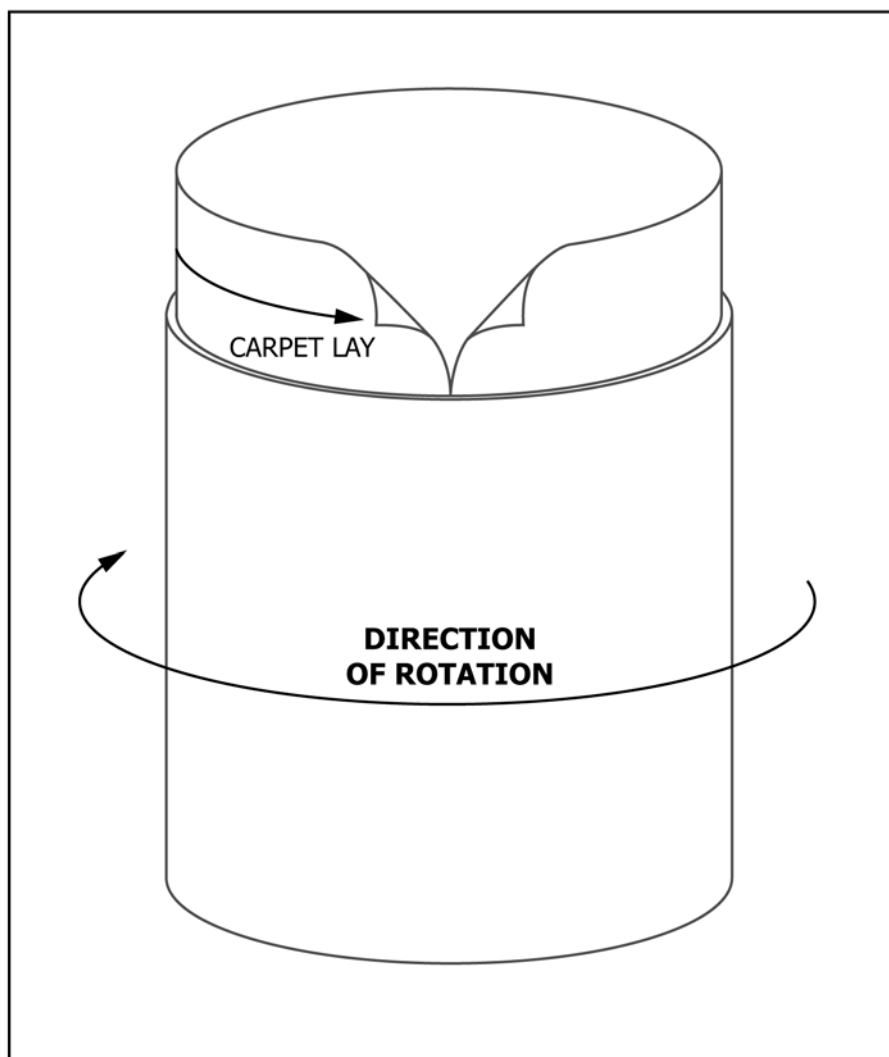

FIG. 3 Orientation of Carpet Panel in the Soiling Cylinder

9.3 Colorimetric Evaluation Procedure:

9.3.1 Carpet Grooming Procedure—Prior to measuring the L^* , a^* , and b^* values for the carpet panels, the fibers shall be groomed using the Weighted Carpet Grooming Rake. Readings shall be made for each carpet in its virgin, soiled, and cleaned state.

9.3.2 Place the rake on the carpet such that the stroke direction is only in the direction WITH the lay in all cases. Pull the rake across the carpet at 0.20 m/s (8.0 in./s) taking care to keep the tines perpendicular to the carpet surface. Repeat this step for a total of 5 strokes with no indexing. Note that all strokes begin at the same end of the carpet.

9.3.3 Using the carpet color measurement template and the colorimetric measuring equipment measure the L^* , a^* , and b^* values of the carpet panel at the same ten (10) measurement locations on each carpet panel. The weight shall be added to the instrument during measurements to provide consistent pressure of the plate on the measurement surface per section 5.6.

NOTE 4—Care should be taken to minimize disturbance of the carpet fibers after grooming if carpet panels are to be transported from the floor

to a bench top to perform color measurements.

9.4 Carpet Soiling Procedure:

9.4.1 Ensure that the carpet soiling cylinders and chrome alloy steel balls are clean and dry.

9.4.2 Each carpet panel is fitted into a soiling cylinder. Care must be taken to orient the panels correctly in the soiling cylinder(s) as shown in Fig. 3 to ensure proper direction of rotation during tumbling.

9.4.3 Spread 2000 ± 2 g (70.6 ± 0.07 oz) clean, chrome alloy steel balls evenly along the seam of the carpet inside the carpet soiling cylinder. Distribute the predetermined amount of soiled polymer pellets on top of the chrome alloy steel balls and secure the lid. Rotate the cylinder in the direction shown in Fig. 3 at 0.58 r/s 35 rpm for 15 min. After 15 min, reverse the direction of the rollers or reverse the orientation of the cylinder in order to rotate in the opposite direction for an additional 15 min.

NOTE 5—The amount of soiled pellets must be predetermined to provide a ΔE of 12.0 ± 1.0 between “virgin” and “soiled” conditions. See section 10.1 for determining ΔE .

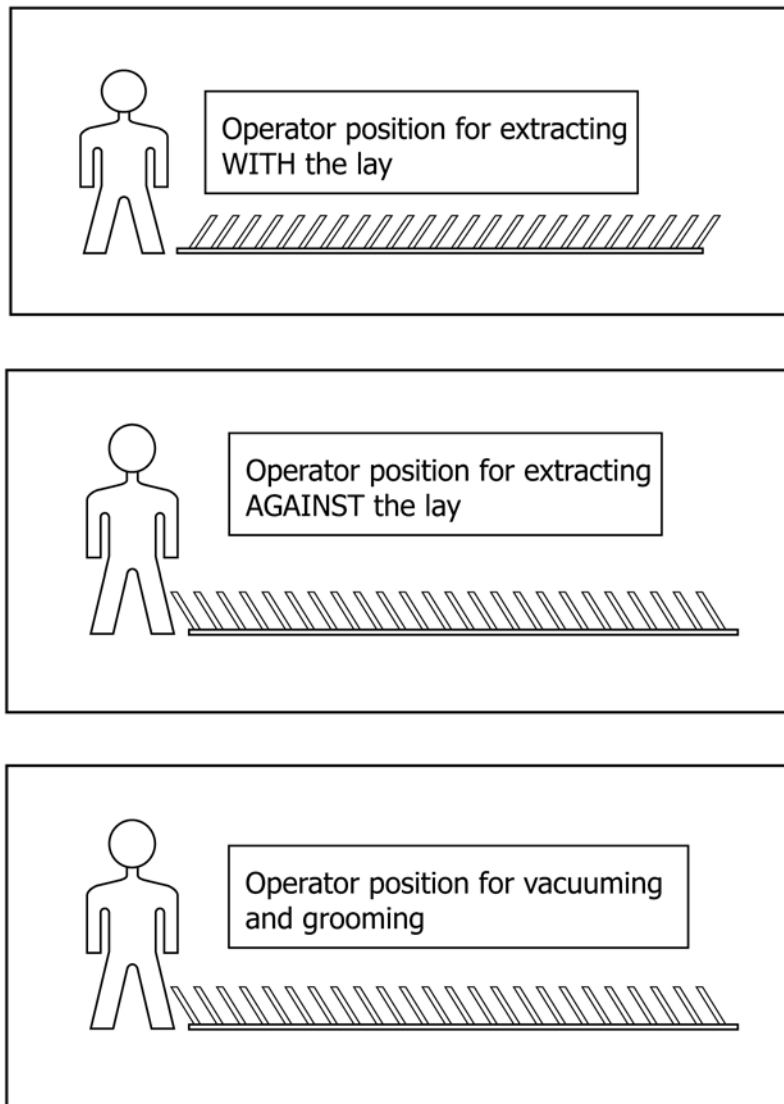

FIG. 4 Carpet Lay Direction and Orientation

9.4.4 Remove the chrome alloy steel balls and pellets from the cylinder. The steel balls may be re-used. The pellets shall not be re-used.

9.4.5 Carefully remove the carpet panel from the soiling cylinder making sure the carpet pile does not come into contact with any other part of the carpet.

9.4.6 Remove any loose pellets from the carpet panel.

9.4.7 Vacuum the carpet panel with the SOILED CARPET rotating agitator vacuum cleaner for 16 strokes at 0.55 m/s (1.8 ft/s). Eight strokes on each side of the carpet starting on the right side and indexing after the eighth stroke to the opposite side. Allowance should be made for the belt guard so that the entire area is cleaned with agitation. The first forward stroke should be AGAINST the lay of the carpet in all cases.

9.4.8 Using the procedure described in 9.3, evaluate the soiled carpet panel to establish the soiled readings.

9.4.9 Calculate the ΔE between the virgin and soiled readings to ensure that the ΔE value of 12.0 ± 1.0 has been achieved. Adjust the amount of soiled polyamide polymer pellets and start over if the ΔE is outside of this range. See section 10.1 to calculate ΔE .

9.4.10 The soiled carpets must be used within 14 days of soiling.

NOTE 6—It is important when performing comparative testing of product models that the carpet and soil be taken from the same lots.

9.5 Cleaning Procedure:

9.5.1 New Wet Extraction Cleaner Preparation:

9.5.1.1 Precondition a new wet extraction cleaner by running the unit for 1 hour at its rated voltage $\pm 1\%$ and rated frequency with tanks and any filters in place. All units should be in a stationary position with a wide-open inlet assuring any

agitator bristles are not engaged on any surface. For units with heaters, the heater should be ON and one tank of solution should be run through the system.

9.5.1.2 Purge the solution lines with clean, hot water $49 \pm 2^\circ\text{C}$ ($120 \pm 3^\circ\text{F}$) by operating the distribution system for a minimum of 2 min. If a separate detergent tank is present, this tank shall be filled with water and purged as well.

9.5.1.3 Empty the solution and recovery tanks and drain any remaining water from the solution/water reservoir.

9.5.2 *Used Wet Extraction Cleaner Reconditioning:*

9.5.2.1 Without using tools for disassembly, clean the entire outer surface, brushes, nozzle, and ductwork. Examine the cleaner for any signs of damage or visible operational defects.

9.5.2.2 Thoroughly rinse the water, detergent, solution, and recovery tanks (if present) to remove any residue from previous cleaning test(s).

9.5.2.3 Fill and clean the solution tank/water reservoir tanks with clean, hot water $49 \pm 2^\circ\text{C}$ ($120 \pm 3^\circ\text{F}$), and activate the solution dispensing system to remove any residual chemicals from the distribution system. Empty any remaining water from the tanks and distribution system.

9.5.2.4 Insert test carpets into the carpet cleaning template. The template and test carpets shall be supported by carpet padding.

9.5.3 *Preparation of Solution Tank/Water Reservoir for Testing:*

9.5.3.1 *Pre-Mix Systems:*

(1) Fill the solution tank with tap water at $49 \pm 2^\circ\text{C}$ ($120 \pm 3^\circ\text{F}$) and the proper amount of cleaning chemicals per the manufacturer's instructions. Contact the manufacturer if no recommended formula is provided or if recommended formula is not commercially available or if the instructions are unclear or inadequate.

NOTE 7—It is permissible to mix the water and formula in a separate container at the specified temperature and then immediately pour the mixture into the solution tank for testing.

9.5.3.2 *Self-Mix / Auto-Mix Systems:*

(1) Fill the water reservoir with tap water at $49 \pm 2^\circ\text{C}$ ($120 \pm 3^\circ\text{F}$).

(2) Fill the cleaning chemical reservoir with the manufacturer's suggested chemical per instructions. If cleaning chemical is packaged with the wet extraction cleaner, only that cleaning chemical is to be used if commercially available at the time of test. Contact the manufacturer if no recommended formula is provided or if the recommended formula is not commercially available.

(3) Set the auto-mix adjustment, if present, for normal cleaning.

9.5.3.3 Energize the wet extraction cleaner for 1 min at the nameplate rated voltage $\pm 1\%$ and frequency immediately before conducting the cleaning test. If the unit has dual nameplate voltages, conduct the test at the highest rated voltage.

9.5.3.4 For units with heaters, consult the manufacturer for instructions for heater preparation.

9.5.3.5 Place the wet extraction cleaner onto a piece of scrap test carpet positioned directly adjacent to the test carpet and run with spray for 10 s and then run without spray for 10 s. Repeat

this cycle twice more for a total of 3 spray and 3 non-spray periods. During the third non-spray period, position the wet extraction cleaner at the start of the test carpet panel and begin the test on the next interval of the stroke timer. Begin cleaning the next test carpet without delay if enough solution remains in the supply tank.

9.5.4 *Cleaning Method:*

9.5.4.1 All strokes should start before and end after the ends of the test carpet.

9.5.4.2 Clean each carpet using two (2) wet strokes and then two (2) dry strokes at a rate of 0.20 m/s (8.0 in./s). Each stroke is to be down the center of the carpet. Care should be taken to ensure there is little to no space between strokes.

9.5.4.3 Three (3) carpets are to be cleaned such that the first (forward) stroke is WITH the lay of the carpet fibers and three (3) carpets are to be cleaned such that the first (forward) stroke is AGAINST the lay of the carpet fibers.

9.5.4.4 For backward only machines, three (3) carpets are to be cleaned such that the backward strokes are WITH the lay of the carpet fibers, and three (3) carpets are to be cleaned such that the backward strokes are AGAINST the lay of the carpet fibers.

9.5.4.5 All 6 carpets (3 WITH the lay + 3 AGAINST the lay) are to be cleaned consecutively without changing the cleaning water/solution if possible. All 6 carpets are also to be cleaned as quickly as possible to minimize hot water/solution temperature losses.

9.5.4.6 After wet extraction, the carpets are to be stored horizontally on a ventilated drying rack to dry at standard environmental conditions.

9.5.4.7 Allow carpets to dry a minimum of 16 h, and when dry, vacuum the test carpets with the CLEANED CARPET rotating agitator vacuum cleaner for 16 strokes at 0.55 m/s (1.8 ft/s). Eight strokes on each side of the carpet starting on the right side and indexing after the eighth stroke to the opposite side. Allowance shall be made for the belt guard so that the entire area is cleaned with agitation. The first forward stroke shall be AGAINST the lay of the carpet in all cases.

NOTE 8—It is permissible to employ a gravimetric method for determination of a dry carpet.

9.5.4.8 Evaluate the color of the cleaned carpet using the procedure of section 9.3. Record these measurements as the cleaned values.

10. Cleaning and Performance Rating

10.1 The average L^* , a^* , and b^* values can be compared by converting them to ΔE values. ΔE values measure the total color and brightness difference between two points.

$$\Delta E = \sqrt{(\Delta L^2 + \Delta a^2 + \Delta b^2)} \quad (1)$$

where:

$$\Delta L = L_2 - L_1$$

$$\Delta a = a_2 - a_1$$

$$\Delta b = b_2 - b_1$$

10.2 Calculate the Percent Cleaned using ΔE between the virgin carpet and cleaned carpet (ΔE_1) and ΔE between the soiled carpet and the virgin carpet (ΔE_2) using the following

formula for each test carpet. For each test carpet, calculate the Percent Cleaned value for each of the 10 measurement locations and then average the 10 Percent Cleaned values for the average Percent Cleaned value for the test carpet. See example in [Appendix X4](#).

$$\text{Percent Cleaned} = \left(1 - \frac{\Delta E_1}{\Delta E_2} \right) \times 100 \quad (2)$$

10.3 The average Percent Cleaned for a given model (the test result) is the average of the results for all carpets cleaned with all of the individual units.

11. Report

11.1 For each wet extraction cleaner sample from the population being tested, report the following information:

11.1.1 Manufacturer’s name and product model name and number.

11.1.2 Cleaning chemical identification and date code used in the testing.

11.1.3 Carpet lot production code.

11.1.4 Soil lot date code.

11.1.5 Type of cleaner; upright, canister, backward only cleaner, nozzle width, etc.

11.1.6 Percent Cleaned values calculated for each individual unit for each carpet.

11.1.7 Average Percent Cleaned value for the sample (from section [10.3](#)).

12. Precision and Bias⁵

12.1 The precision of this test method is based on an interlaboratory study conducted in 2009. A single laboratory participated in this study, reporting a total of five replicate results (each the average of multiple measurements taken WITH and AGAINST the natural lay of the carpet fibers) over a period of five testing days. Every “test result” reported represents the average of two determinations (one “WITH” the lay and the other “AGAINST” the lay that are themselves the average of three determinations). Except for the use of only a single laboratory and material, Practice [E691](#) was followed for the design and analysis of the data.

12.1.1 *Repeatability limit (r)*—Two test results obtained within one laboratory shall be judged not equivalent if they differ by more than the “*r*” value for that test unit; “*r*” is the interval representing the critical difference between two test

results for the same test unit, obtained by the same operator using the same equipment on the same day in the same laboratory.

12.1.1.1 Repeatability limits are listed in [Tables 1-3](#) below.

12.1.2 *Reproducibility limit (R)*—Two test results shall be judged not equivalent if they differ by more than the “*R*” value for that unit; “*R*” is the interval representing the critical difference between two test results for the same unit, obtained by different operators using different equipment in different laboratories.

12.1.2.1 Reproducibility limits cannot be calculated from a single laboratory’s results.

12.1.3 The above terms (repeatability limit and reproducibility limit) are used as specified in Practice [E177](#).

12.1.4 Any judgment in accordance with statements [12.1.1](#) and [12.1.2](#) would normally have an approximate 95 % probability of being correct; however, the precision statistics obtained in this ILS must not be treated as exact mathematical quantities which are applicable to all circumstances and uses. The limited number of units tested and laboratories reporting results guarantees that there will be times when differences greater than predicted by the ILS results will arise, sometimes with considerably greater or smaller frequency than the 95 % probability limit would imply. Consider the repeatability limit as a general guide, and the associated probability of 95 % as only a rough indicator of what can be expected.

12.2 *Bias*—At the time of the study, there was no accepted reference material suitable for determining the bias for this test method, therefore no statement on bias is being made.

12.3 The precision statement for the average Percent Cleaned was determined through statistical examination of five averaged results, from a single laboratory, on a single carpet material. See [Appendix X2](#).

13. Keywords

13.1 carpet cleaning; extraction; formula

TABLE 1 Average Percent Cleaned

Material	Average \bar{x}	Repeatability Standard Deviation	Repeatability Limit
		s_r	r
Extractor	49.77	1.02	2.85

⁵ Supporting data have been filed at ASTM International Headquarters and may be obtained by requesting Research Report RR:F11-1020.

**TABLE 2 Percent Cleaned (WITH the natural lay of the fibers)
(for informational purposes only)**

Material	Average \bar{x}	Repeatability Standard Deviation s_r	Repeatability Limit r
Extractor	44.08	1.75	4.91

**TABLE 3 Percent Cleaned (AGAINST the natural lay of the fibers)
(for informational purposes only)**

Material	Average \bar{x}	Repeatability Standard Deviation s_r	Repeatability Limit r
Extractor	55.45	0.91	2.54

APPENDIXES

(Nonmandatory Information)

X1. CARPET AND PELLET SOILING CYLINDER

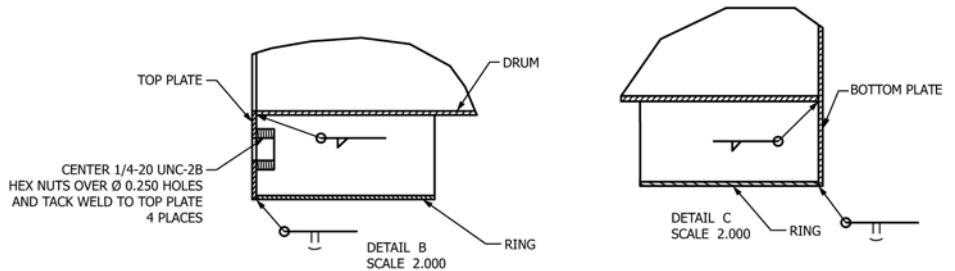
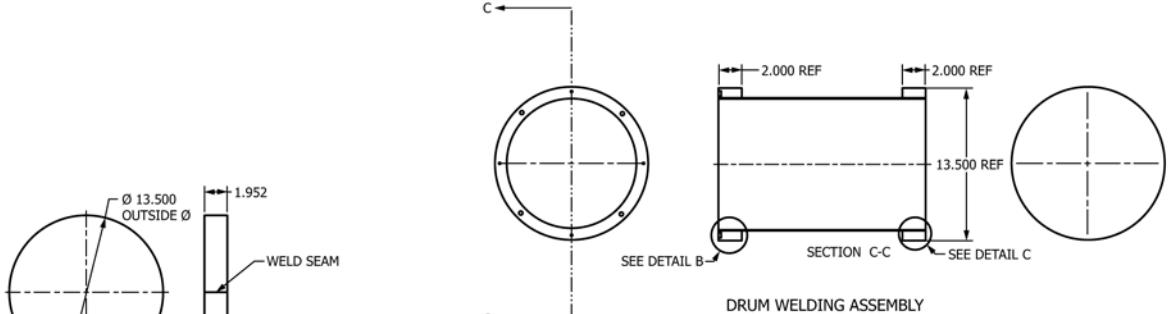
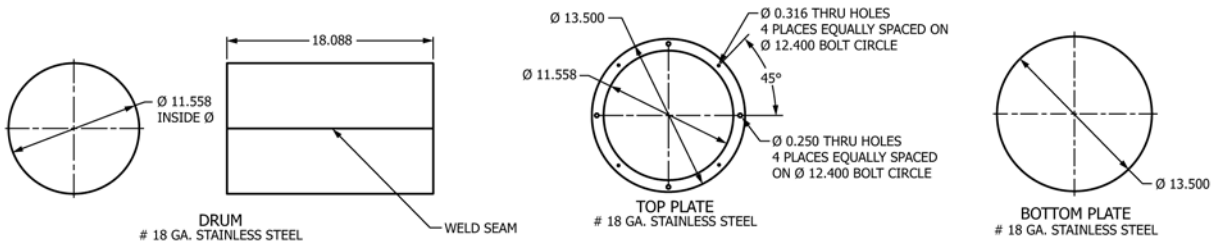
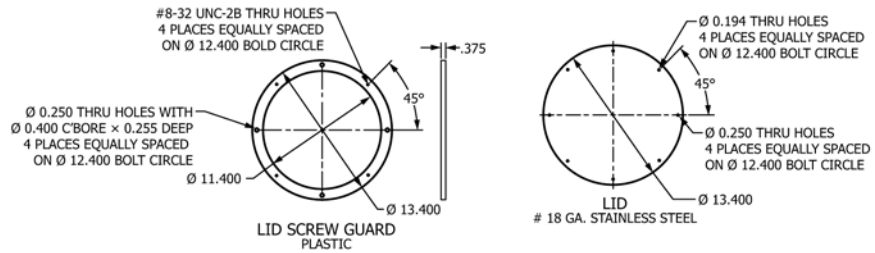
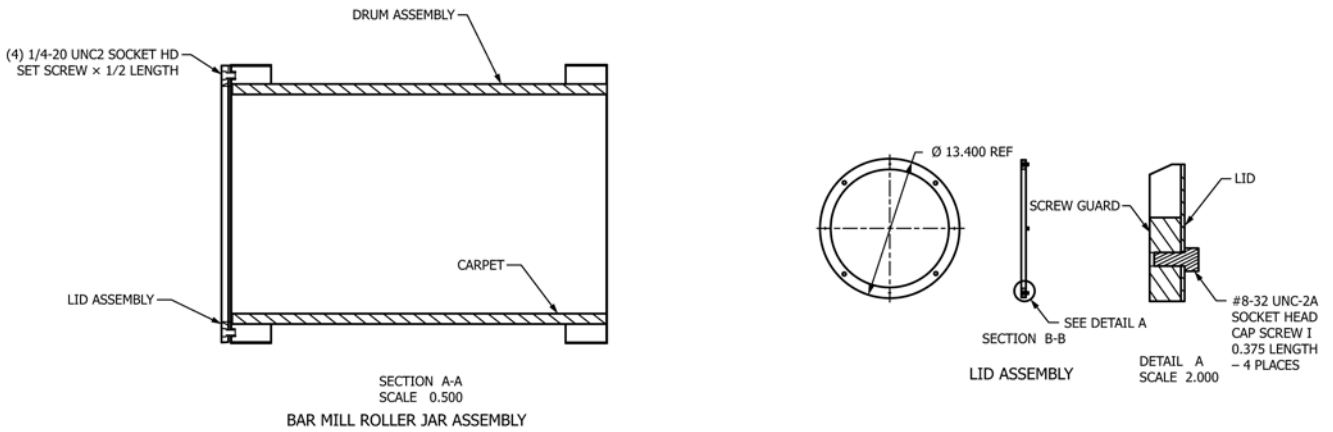

FIG. X1.1 Carpet and Pellet Soiling Cylinder

X2. CARPET SPECIFICATION
X3. PELLET SPECIFICATION (EXAMPLE)
TABLE X2.1 Carpet Specification

Mfg:	Shaw
Style:	Atherton Plus 52A36
Color:	00103 Cashmere
Fiber:	100% BCF Nylon
Width:	12 feet
Treatment:	None

-Product Information

March 2007 ® = registered
trade mark of
BASF Aktiengesellschaft

Ultramid® B27 E

Product description

Ultramid® B27 E is a polyamide 6 grade of low viscosity that is well suited for compounding and the production of monofilaments.

Specification	Test method	Unit	Value
Relative Viscosity (RV) 1% [m/v] in 96% [m/m] sulfuric acid	According to ISO 307 (calculated by Huggins method)		2.62-2.83
Viscosity Number (VN) 0,5% [m/v] in 96% [m/m] sulfuric acid	According to ISO 307	ml/g	142-158
Moisture content	According to ISO 15512	% [m/m]	max. 0.10
Extractables	According to ISO 6427-chips not ground/16h	% [m/m]	max. 0.6
General properties	Test method	Unit	Typical value
Melting point	According to ISO 3146	°C	220
Density	According to ISO 1183	g/cm ³	1.12-1.15
Bulk density		kg/m ³ P	780
Pellet size		mm	2 - 2.5
Pellet shape		round	
Water absorption, 23°C/50% rh		%	2.2
Water absorption, saturation in water 23°C		%	8.5

FIG. X3.1 Pellet Specification (Example)

X4. SAMPLE CLEANING PERFORMANCE DATA

ASTM DRAFT CLEANING TEST														
Test Unit	_____						DateCode/Serial #	_____			Test #	_____		
Formula:	_____						Date Code/Batch#:	_____			Date	_____		
Carpet Type:	Carpet						Procedure:	ASTM Draft			RH	50		
Comments/ Exceptions:	_____										AMB	70		
	_____										Dirty Made	_____		
	_____										Cleaned by	_____		
	_____										Mix Type:	_____		
	_____										Carpet Roll	_____		
Carpet #:	1112						Project:	_____						
Cleaning Direction	Wlay													
Averaged Cleaning Performance Data														
	Virgin Carpet			Soiled			Extracted			Delta E Values			% Clean	
	L	a	b	L	a	b	L	a	b	v-e	v-s	s-e		1-[DE(v-e)/DE(v-s)]
1112-1	75.26	0.90	12.92	64.20	1.95	10.09	66.76	1.29	10.82	8.77	11.47	2.74	23.50%	
1112-2	75.32	0.90	12.94	64.52	1.95	10.28	67.23	1.28	10.92	8.35	11.17	2.86	25.26%	
1112-3	75.18	0.92	12.96	64.42	1.94	10.29	67.01	1.28	10.99	8.41	11.13	2.76	24.44%	
Average	75.25	0.91	12.94	64.38	1.95	10.22	67.00	1.28	10.91	8.51	11.26	2.79	24.40%	
Std Dev	0.07	0.01	0.02	0.16	0.01	0.11	0.24	0.01	0.08	0.23	0.18	0.06	0.88%	
Range	0.14	0.02	0.04	0.32	0.01	0.20	0.47	0.01	0.17	0.42	0.34	0.12	1.75%	
Detailed Cleaning Performance Data														
Carpet ID	Reading	Virgin			Soiled			Extracted			Delta E Values			% Clean
1112-1		L	a	b	L	a	b	L	a	b	v-e	v-s	s-e	
	1	75.32	0.90	12.91	64.12	1.97	10.13	67.13	1.26	10.92	8.44	11.59	3.19	27.20%
	2	75.13	0.92	12.99	64.56	1.93	10.17	66.77	1.28	11.02	8.60	10.99	2.46	21.80%
	3	75.35	0.92	13.00	63.77	1.96	10.03	66.45	1.29	10.76	9.18	11.99	2.85	23.43%
	4	75.10	0.90	13.00	64.32	1.94	10.02	66.67	1.27	10.74	8.73	11.23	2.55	22.27%
	5	75.36	0.90	12.95	64.28	2.00	10.23	66.35	1.38	10.96	9.24	11.46	2.28	19.36%
	6	75.56	0.88	12.88	64.30	1.94	10.04	67.36	1.24	10.79	8.46	11.66	3.23	27.40%
	7	75.17	0.91	12.94	63.87	1.96	10.00	66.36	1.31	10.73	9.09	11.72	2.67	22.42%
	8	75.19	0.91	12.87	64.26	1.94	10.03	67.14	1.25	10.66	8.36	11.35	3.03	26.33%
	9	75.29	0.87	12.78	64.36	1.93	10.04	66.63	1.33	10.79	8.90	11.32	2.46	21.31%
	10	75.18	0.89	12.83	64.18	1.98	10.23	66.71	1.31	10.83	8.71	11.36	2.69	23.29%
	Average	75.26	0.90	12.92	64.20	1.95	10.09	66.76	1.29	10.82	8.77	11.47	2.74	23.48%
	Std Dev	0.14	0.02	0.07	0.23	0.03	0.09	0.35	0.04	0.11	0.32	0.28	0.33	2.68%
	Range	0.46	0.05	0.22	0.78	0.08	0.23	1.02	0.14	0.36	0.89	1.00	0.95	8.04%
Carpet ID	Reading	Virgin			Soiled			Extracted			Delta E Values			% Clean
1112-2		L	a	b	L	a	b	L	a	b	v-e	v-s	s-e	
	1	75.37	0.90	12.95	64.74	1.94	10.25	67.49	1.26	10.90	8.14	11.02	2.91	26.09%
	2	75.38	0.89	12.92	64.70	1.93	10.22	67.52	1.26	11.04	8.09	11.06	3.01	26.86%
	3	75.11	0.93	13.01	64.35	1.95	10.24	67.13	1.27	10.96	8.24	11.15	2.95	26.07%
	4	75.31	0.92	13.06	64.57	1.94	10.33	67.09	1.29	10.98	8.49	11.13	2.68	23.70%
	5	75.51	0.90	12.93	64.45	1.99	10.24	67.05	1.31	10.90	8.71	11.43	2.77	23.82%
	6	75.56	0.87	12.93	64.99	1.91	10.34	67.72	1.23	10.94	8.10	10.94	2.88	25.93%
	7	75.39	0.88	12.84	64.95	1.91	10.23	67.41	1.26	10.90	8.22	10.81	2.63	23.98%
	8	75.23	0.91	13.01	64.05	1.96	10.40	67.56	1.25	10.92	7.96	11.53	3.62	30.99%
	9	75.16	0.91	12.91	64.23	1.96	10.31	66.41	1.36	10.86	9.00	11.28	2.32	20.24%
	10	75.18	0.87	12.86	64.17	1.95	10.26	66.89	1.31	10.80	8.55	11.36	2.85	24.78%
	Average	75.32	0.90	12.94	64.52	1.95	10.28	67.23	1.28	10.92	8.35	11.17	2.86	25.25%
	Std Dev	0.15	0.02	0.07	0.32	0.02	0.06	0.39	0.04	0.07	0.33	0.23	0.33	2.76%
	Range	0.46	0.05	0.22	0.94	0.08	0.18	1.31	0.13	0.24	1.04	0.73	1.30	10.76%
Carpet ID	Reading	Virgin			Soiled			Extracted			Delta E Values			% Clean
1112-3		L	a	b	L	a	b	L	a	b	v-e	v-s	s-e	
	1	75.35	0.90	12.90	64.14	1.94	10.09	67.04	1.27	10.83	8.58	11.61	3.07	26.13%
	2	75.11	0.91	12.99	64.27	1.96	10.25	66.68	1.28	11.11	8.65	11.24	2.66	23.07%
	3	75.23	0.91	12.96	64.26	1.95	10.15	65.99	1.35	11.04	9.44	11.37	2.04	16.94%
	4	75.15	0.94	12.99	64.55	1.92	10.27	67.71	1.21	10.90	7.73	10.98	3.29	29.58%
	5	75.29	0.93	12.99	64.53	1.96	10.37	66.85	1.31	11.16	8.65	11.13	2.54	22.29%
	6	75.21	0.90	12.94	64.21	1.93	10.10	67.30	1.25	10.79	8.21	11.42	3.24	28.06%
	7	75.18	0.90	12.90	64.39	1.92	10.16	66.57	1.29	10.83	8.86	11.18	2.37	20.73%
	8	75.11	0.93	12.97	64.40	1.95	10.33	67.59	1.24	10.95	7.79	11.07	3.32	29.63%
	9	75.16	0.93	12.95	64.73	1.96	10.55	67.42	1.27	11.15	7.95	10.75	2.85	26.07%
	10	74.99	0.94	12.98	64.77	1.94	10.60	66.97	1.31	11.15	8.24	10.55	2.35	21.84%
	Average	75.18	0.92	12.96	64.42	1.94	10.29	67.01	1.28	10.99	8.41	11.13	2.77	24.43%
	Std Dev	0.10	0.02	0.04	0.22	0.02	0.18	0.52	0.04	0.15	0.53	0.32	0.45	4.15%
	Range	0.36	0.04	0.09	0.63	0.04	0.51	1.71	0.14	0.38	1.71	1.06	1.28	12.69%

FIG. X4.1 Sample Cleaning Performance Data

X5. CARPET COLOR MEASUREMENT TEMPLATES (VARIOUS SIZES)

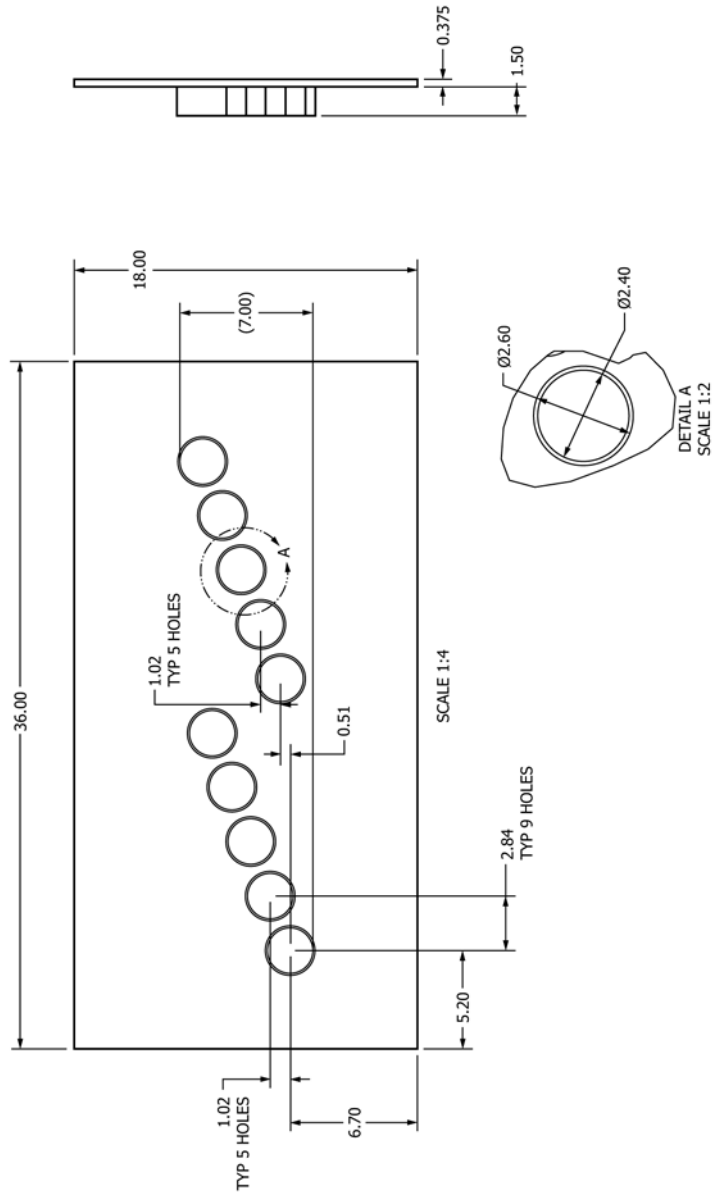

FIG. X5.1 9-in. Template (for Nozzles 9.00 to 9.99 in.)

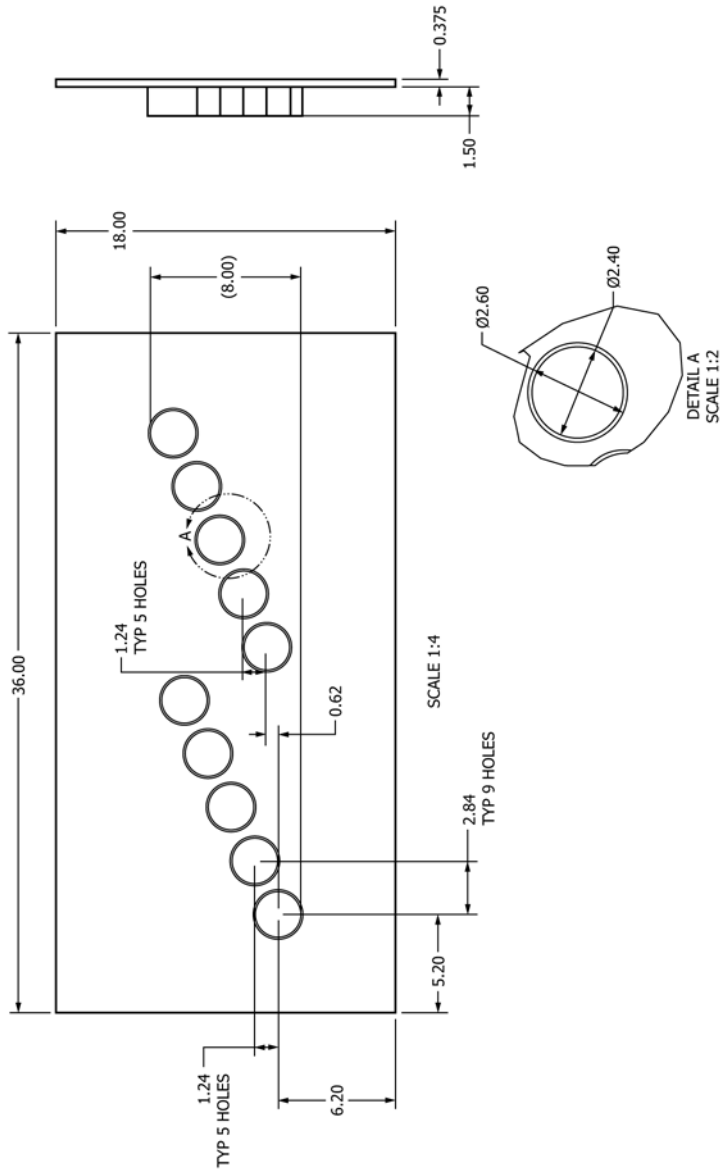

FIG. X5.2 10-in. Template (for Nozzles 10.00 to 10.99 in.)

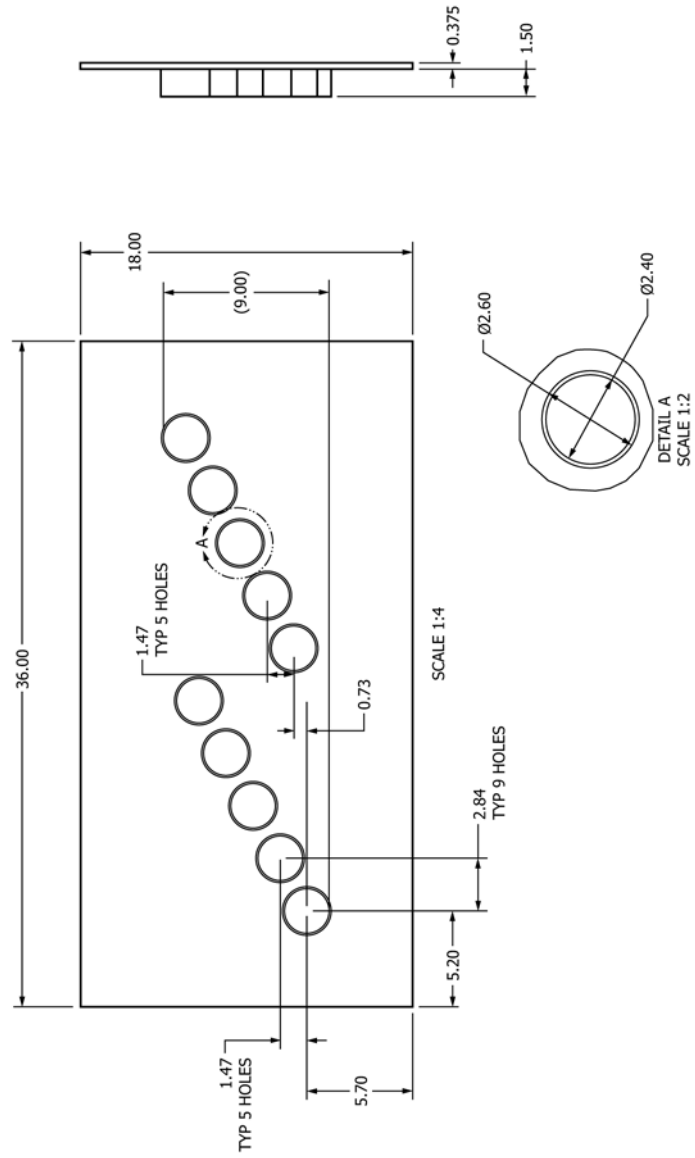

FIG. X5.3 11-in. Template (for Nozzles 11.00 to 11.99 in.)

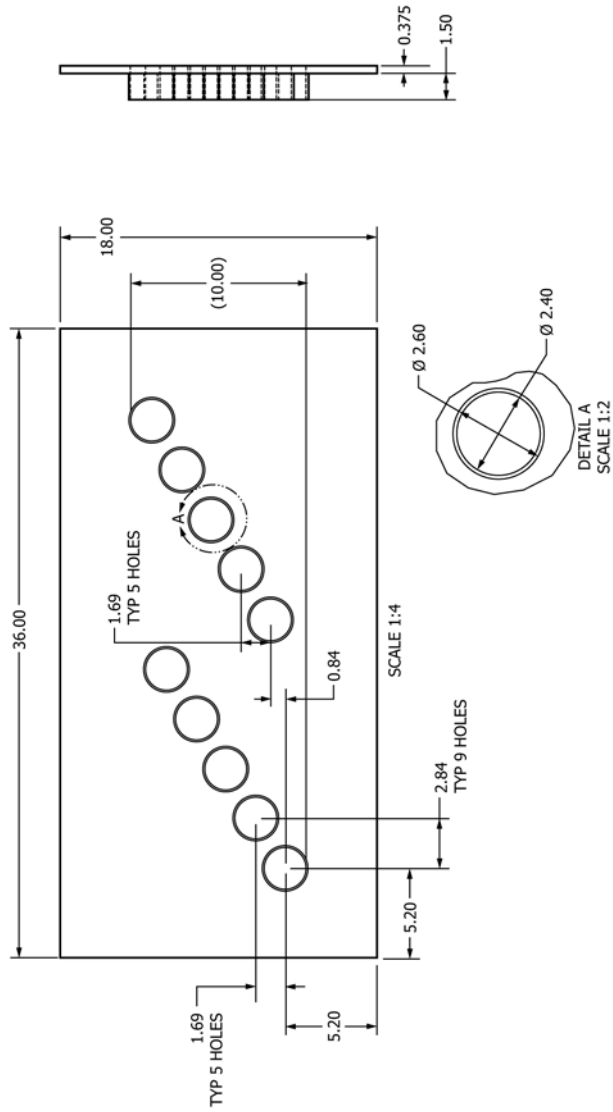

FIG. X5.4 12-in. Template (for Nozzles 12.00 to 12.99 in.)

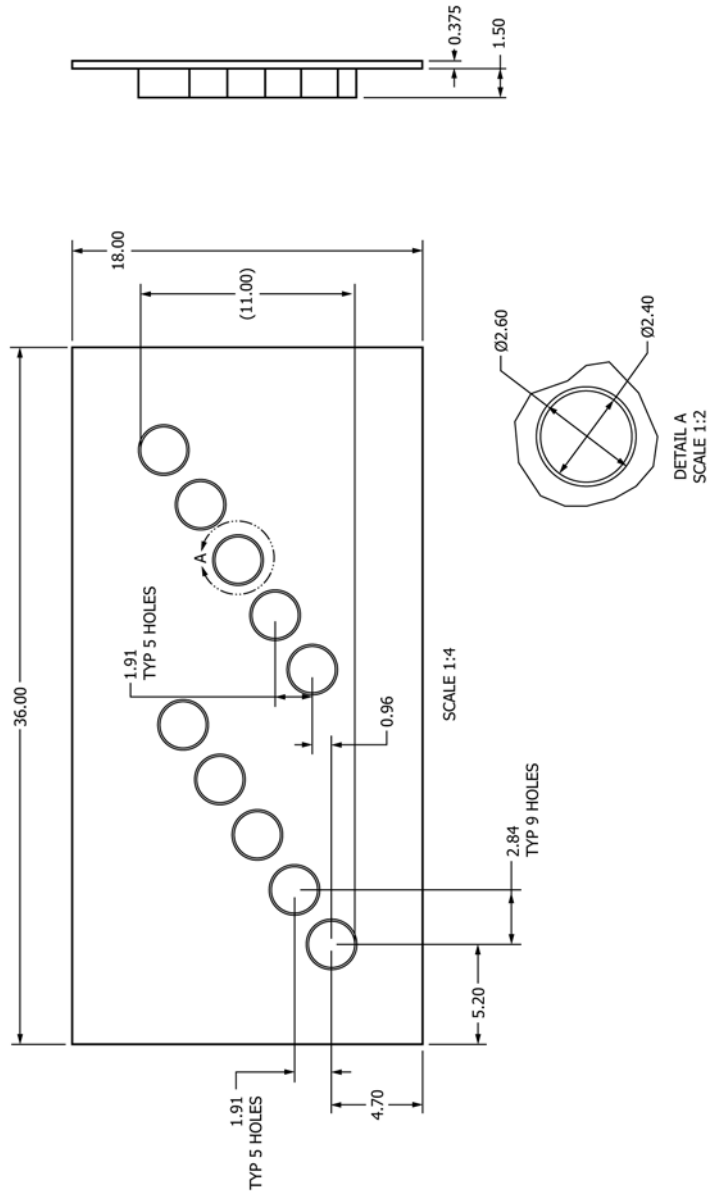

FIG. X5.5 13-in. Template (for Nozzles 13.00 to 13.99 in.)

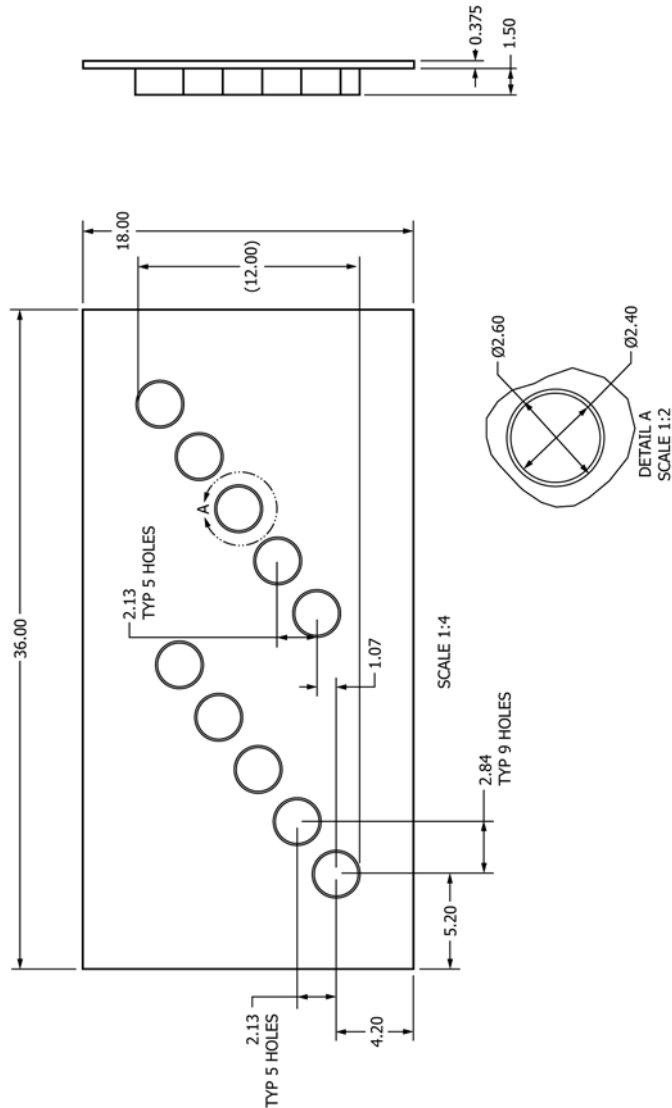

FIG. X5.6 14-in. Template (for Nozzles 14.00 to 14.99 in.)

ASTM International takes no position respecting the validity of any patent rights asserted in connection with any item mentioned in this standard. Users of this standard are expressly advised that determination of the validity of any such patent rights, and the risk of infringement of such rights, are entirely their own responsibility.

This standard is subject to revision at any time by the responsible technical committee and must be reviewed every five years and if not revised, either reapproved or withdrawn. Your comments are invited either for revision of this standard or for additional standards and should be addressed to ASTM International Headquarters. Your comments will receive careful consideration at a meeting of the responsible technical committee, which you may attend. If you feel that your comments have not received a fair hearing you should make your views known to the ASTM Committee on Standards, at the address shown below.

This standard is copyrighted by ASTM International, 100 Barr Harbor Drive, PO Box C700, West Conshohocken, PA 19428-2959, United States. Individual reprints (single or multiple copies) of this standard may be obtained by contacting ASTM at the above address or at 610-832-9585 (phone), 610-832-9555 (fax), or service@astm.org (e-mail); or through the ASTM website (www.astm.org). Permission rights to photocopy the standard may also be secured from the Copyright Clearance Center, 222 Rosewood Drive, Danvers, MA 01923, Tel: (978) 646-2600; http://www.copyright.com/