



Standard Test Methods for Evaluating Design and Performance Characteristics of Elliptical Trainers¹

This standard is issued under the fixed designation F2811; the number immediately following the designation indicates the year of original adoption or, in the case of revision, the year of last revision. A number in parentheses indicates the year of last reapproval. A superscript epsilon (ϵ) indicates an editorial change since the last revision or reapproval.

INTRODUCTION

The goal of these test methods is to provide reliable and repeatable methods for the evaluation of elliptical trainers. The equipment user must recognize, however, that a standard alone will not necessarily prevent injuries. Like other physical activities, exercise involving fitness equipment involves the risk of injury, particularly if the equipment is used improperly or not properly maintained. In addition, users with physical limitations should seek medical advice or instruction from the fitness facility, or both, prior to using this equipment. Certain physical conditions or limitations may preclude some persons from using this equipment properly and without increasing the risk of serious injury.

1. Scope

1.1 These test methods specify procedures and equipment used for testing and evaluating elliptical trainers for compliance to Specification **F2810**. Both design and operational parameters will be evaluated. Where possible and applicable, accepted test methods from other recognized bodies will be used and referenced. In case of a conflict between this document and Specification **F2810**, Specification **F2810** takes precedence.

1.2 *Requirements*—An elliptical trainer is to be tested for all of the following parameters:

- 1.2.1 Endurance,
- 1.2.2 Static loading,
 - 1.2.2.1 Handlebars
 - 1.2.2.2 Foot supports
- 1.2.3 Adjustable guide systems,
- 1.2.4 Control panel,
- 1.2.5 Warnings, and
- 1.2.6 Documentation.

1.3 This test method² contains additional requirements to address the accessibility of the equipment for persons with disabilities.

1.4 The values stated in SI units are to be regarded as the standard. The values in parenthesis are for information only.

1.5 *This standard does not purport to address all of the safety concerns, if any, associated with its use. It is the responsibility of the user of this standard to establish appropriate safety and health practices and determine the applicability of regulatory limitations prior to use.*

2. Referenced Documents

2.1 *ASTM Standards*:³

- F1749** Specification for Fitness Equipment and Fitness Facility Safety Signage and Labels
- F2276** Specification for Fitness Equipment
- F2571** Test Methods for Evaluating Design and Performance Characteristics of Fitness Equipment
- F2810** Specification for Elliptical Trainers
- F3021** Specification for Universal Design of Fitness Equipment for Inclusive Use by Persons with Functional Limitations and Impairments
- F3022** Test Method for Evaluating the Universal Design of Fitness Equipment for Inclusive Use by Persons with Functional Limitations and Impairments

3. Terminology

3.1 *Definitions*—For definitions applicable to this standard, see Specifications **F2810** and **F3021**.

³ For referenced ASTM standards, visit the ASTM website, www.astm.org, or contact ASTM Customer Service at service@astm.org. For *Annual Book of ASTM Standards* volume information, refer to the standard's Document Summary page on the ASTM website.

¹ These test methods are under the jurisdiction of ASTM Committee **F08** on Sports Equipment, Playing Surfaces, and Facilities and is the direct responsibility of Subcommittee **F08.30** on Fitness Products.

Current edition approved Dec. 1, 2015. Published February 2016. Originally approved in 2010. Last previous edition approved in 2010 as F2811 – 10. DOI: 10.1520/F2811-15.

² This work was funded, in part, by the Rehabilitation Engineering Research Center on RecTech through the National Institute on Disability and Rehabilitation Research under the US Department of Education grant #H133E070029 and H133E120005.

4. Significance and Use

4.1 The purpose of these test methods is to provide reliable and repeatable test methods for the evaluation of elliptical trainers assembled and maintained according to the manufacturer's specifications. Use of these test methods, in conjunction with Specification F2810, is intended to ensure appropriate performance and reliability of an elliptical trainer and reduce the risk of serious injury from design deficiencies.

5. Sample Preparations

5.1 Assemble and adjust the elliptical trainer on a horizontal surface according to the manufacturer's instructions. On trainers that are fully assembled, verify according to the manufacturer's instructions that all components are functioning and that they have been adjusted and aligned properly. Unless otherwise stated, the trainer must pass the following tests without adjustment from this initial condition. Apply power to, if required, or use the trainer and verify that the unit functions properly. If the unit is equipped with a guide system, operate it through its full range.

5.2 The individual test methods will describe any variations or modifications that are required to the test sample.

5.3 Upon completion of the tests the equipment shall function as intended by the manufacturer.

6. Test Methods and Procedures

6.1 In addition to the tests specified in Test Methods F2571, elliptical trainers shall be evaluated as follows:

6.2 Exterior Design:

6.2.1 *Foot Supports*—The purpose of this test is to evaluate the dimensions of the foot supports used on the sample.

6.2.1.1 *Apparatus and Set Up*—The sample shall be set up as described in 5.1.

6.2.1.2 *Calibration*—Verify that the measurement device is properly calibrated and has a resolution of 1 mm (0.04 in.).

6.2.1.3 *Procedure*—Measure the dimensions of the slip resistant area of the pedal. Measure the guard heights of the pedal at the front and inside edges. Check for pinch or shear points along the outer edge of the footplate per Specification F2276 and Test Methods F2571. If pinch or shear points exist, measure the guard height of the pedal at the outside edge.

6.2.1.4 *Pass/Fail Criteria*—The dimensions of the slip resistant surface of each pedal shall conform to dimensional requirements of subsection 5.1 of Specification F2810.

6.2.1.5 *Precision and Bias:*

(1) *Precision*—The precision of this test method has not been determined.

(2) *Bias*—The bias of this test method includes quantitative estimates of the uncertainties of the measuring devices, the calibrations of testing equipment and the skill of the operators. At this time, the statements on bias should be limited to documented performance of particular laboratories.

6.2.2 *Handlebars*—The purpose of this test is to verify the existence of the handlebar.

6.2.2.1 *Apparatus and Set Up*—The sample shall be set up as described in 5.1.

6.2.2.2 *Calibration*—No calibration required.

6.2.2.3 *Procedure*—Visually verify the presence of a handlebar.

6.2.2.4 *Pass/Fail Criteria*—The handlebar must be present and conform to the requirements of subsection 5.2 of Specification F2810.

6.2.2.5 *Precision and Bias*—No information is presented about either the precision or bias of this test since the test result is non-quantitative.

6.2.3 *Movable Handlebar Design*—The purpose of this test is to evaluate the dimensions of the movable handlebars used on the sample.

6.2.3.1 *Apparatus and Set Up*—The sample shall be set up as described in 5.1.

6.2.3.2 *Calibration*—Verify that the measurement device is properly calibrated and has a resolution of 1 mm (0.04 in.).

6.2.3.3 *Procedure*—Measure the dimensions of the end portion of the movable handlebar. The evaluator shall also use the elliptical trainer per the manufacturer's instructions and observe the orientation of the end portion of the movable handlebars with respect to the head of the evaluator throughout the range of travel of the movable handlebars.

6.2.3.4 *Pass/Fail Criteria*—The dimension of the end portion of the movable handlebar shall conform to dimensional requirements of subsection 5.2 of Specification F2810. Alternately, if the end portion of the movable handlebars is always angled away from the user during operation of the elliptical trainer then it shall be concluded that the movable handlebars meet the requirements of the specifications.

6.2.3.5 *Precision and Bias:*

(1) *Precision*—The precision of this test method has not been determined.

(2) *Bias*—The bias of this test method includes quantitative estimates of the uncertainties of the measuring devices, the calibrations of testing equipment and the skill of the operators. At this time, the statements on bias should be limited to documented performance of particular laboratories.

6.3 *Endurance*—The purpose of this test is to confirm the endurance of the main components of the elliptical trainer. Load input to the elliptical trainer can be accomplished by securing weight to the foot pedals and lifting the weight using pneumatic cylinders, or by pushing down with pneumatic cylinders (with or without weight). Regardless of how the load is input to the elliptical trainer under test, careful consideration shall be given by the testing facility as to how the test apparatus is constructed. The testing facility shall communicate with the manufacturer prior to commencing the test and verify that the apparatus functions and loads the elliptical trainer in a manner similar to how a user would actually use and interface with the elliptical trainer. Figs. 1 and 2 illustrate pneumatic apparatuses that have been used successfully to conduct endurance testing. The elliptical trainer shown in Fig. 2 is driven by the two pneumatic cylinders which are attached to the footplates of the device under test. The cylinders can be pivoted or mounted to linear bearings on the test apparatus frame so that the cylinders are able to follow the horizontal motions of the elliptical pedals. The timing of the cylinder actuations can be such that the pistons are pushing downward generally synchronous to the downward motion of the footplate as it follows the elliptical

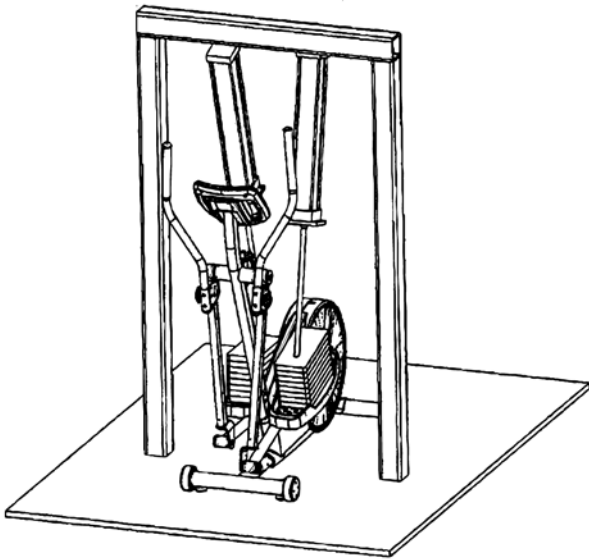

FIG. 1 Isometric View of a Pivoting Test Apparatus

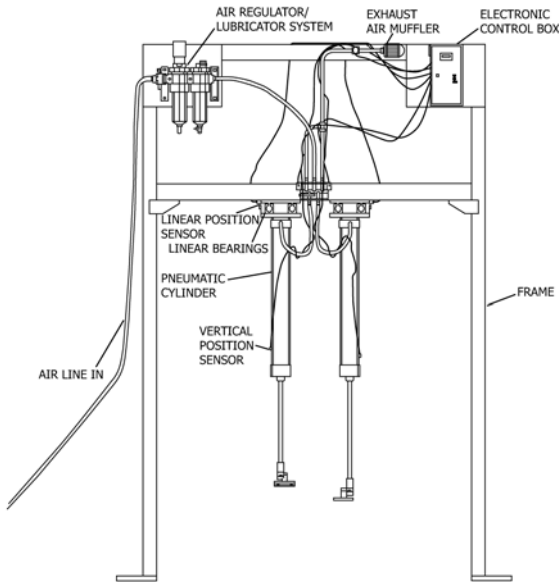

FIG. 2 View of a Test Apparatus With Linear Bearings

path. By timing the firing of the cylinders correctly, along with varying the braking resistance, this setup will drive the elliptical trainer. Horizontal loading of the moveable handlebars (if equipped) can be accomplished by connecting the handlebars to hanging weights using a cable over a pulley. Other methods include but are not limited to un-powered air cylinders with controlled venting, connection to elastic materials, a clamped weight positioned so that the peak load in the dynamic direction is 5 % of the maximum specified user weight or a pneumatic cylinder applying a reversed cyclic load of 5 % of the maximum specified user weight to handlebars that are held static in a test fixture.

6.3.1 *Apparatus and Set Up*—The sample shall be set up as described in 5.1. Obtain instruction or a descriptive explanation of the function of the sample equipment from the manufacturer. A method of recording the number of cycles shall be provided.

6.3.2 *Calibration*—Verify that the load application system is calibrated and is accurate to within 5 % of the applied load. Verify that the counting device changes the displayed counts by 1 for each full revolution of one foot pedal for at least 100 cycles.

6.3.3 *Procedure*—Construct and attach the resistance and cycling means to the elliptical trainer and verify that it functions as intended by the manufacturer. The testing apparatus shall move the foot supports through their complete cycle in the same manner that the user does. Apply the test load to the pedals. Set the braking resistance to 80 % of the possible resistance capable by the brake or 300 watts, whichever is less. The speed of the test is dependant on the pedal loading and the brake resistance setting. Therefore, there will not be a stringent requirement for the speed of this test. It is recommended that speed end up between 30 and 60 cycles per minute, (one cycle = one full revolution of the pedal) once the pedal loading and the brake resistance have been set. The duty cycle of the test shall be a minimum of 50 % on and 50 % off, with a minimum on time of 30 min.

6.3.3.1 Verify that the counter cycles for each repetition of the elliptical trainer and then periodically throughout the duration of the test. If the test apparatus is to run unattended, then it shall be outfitted with a means of stopping if failure occurs on the sample. Begin the test. Periodically make and record observations during the test.

6.3.4 *Pass/Fail Criteria*—Upon completion of the cycles specified in Specification F2810, the trainer shall function as per the operation instructions provided by the manufacturer and conform to the requirements of subsection 5.3 of Specification F2810.

6.3.5 *Precision and Bias:*

6.3.5.1 *Precision*—The precision of this test method has not been determined.

6.3.5.2 *Bias*—The bias of this test method includes quantitative estimates of the uncertainties of the measuring devices, the calibrations of testing equipment and the skill of the operators. At this time, the statements on bias should be limited to documented performance of particular laboratories.

6.4 *Static Loading of Structures*—The purpose of this test is to evaluate the static structural integrity of the foot supports, any frame structure and user supports (moveable and static handlebars), as applicable to user safety.

6.4.1 *Handlebars*—The purpose of this test is to confirm structural integrity of handlebars in the vertical and horizontally loaded conditions.

6.4.1.1 *Apparatus and Set Up*—The sample shall be set up as described in 5.1. Supply a means of applying a steady state load in both the vertical and horizontal directions. Possible methods of providing that force include, but are not limited to, pneumatic cylinder(s), or dead weights. If necessary, the elliptical trainer may be restrained from movement as long as that restraint does not aid the structure of the user support means. Determine which direction in the horizontal direction would be structurally the weakest.

6.4.1.2 *Calibration*—Verify the load application system is calibrated and is accurate to within ± 5 % of applied load.

6.4.1.3 *Procedure*—Apply a concentrated or point static load to the weakest structural point on the handlebar in the vertical direction. Visually inspect for indications of breakage. Repeat the test applying the load specified in Specification **F2810** in the weakest horizontal direction. Maintain the load for 5 min. Visually inspect the handlebars for indications of breakage.

6.4.1.4 *Pass/Fail Criteria*—The handlebar shall conform to the requirements of subsection 5.2.2 of Specification **F2810** and not break.

6.4.1.5 *Precision and Bias*:

(1) *Precision*—The precision of this test method has not been determined.

(2) *Bias*—The bias of this test method includes quantitative estimates of the uncertainties of the measuring devices, the calibrations of testing equipment and the skill of the operators. At this time, the statements on bias should be limited to documented performance of particular laboratories.

6.4.2 *Foot Support*—The purpose of this test is to evaluate the static structural integrity of the foot supports that are designed for the user to step or stand on.

6.4.2.1 *Apparatus and Set Up*—The sample shall be setup as described in **5.1**. Supply a means of providing a steady state load (pneumatic cylinder(s) weights, etc.) on foot pedals or other foot support locations, capable of adjustment to apply vertical load to the test member at minimum, mid-range and maximum incline for elliptical trainers with incline adjustment. Load is to be applied on a 100 by 100 mm (3.9 by 3.9 in.) square area located at the most onerous location of each part to be evaluated.

6.4.2.2 *Calibration*—Verify the load application system is calibrated and is accurate to within $\pm 5\%$ of the applied load.

6.4.2.3 *Procedure*—With the foot pedal positioned in the most onerous position and the mechanism of the elliptical trainer fixed to prevent movement, apply the intrinsic test load in accordance with Specification **F2276** for 5 min, then remove the test load and inspect for indications of breakage.

6.4.2.4 *Pass/Fail Criteria*—Pedals and supporting structures shall conform to the requirements of subsection 5.1.1 of Specification **F2810** and not break.

6.4.2.5 *Precision and Bias*:

(1) *Precision*—The precision of this test method has not been determined.

(2) *Bias*—The bias of this test method includes quantitative estimates of the uncertainties of the measuring devices, the calibrations of testing equipment and the skill of the operators. At this time, the statements on bias should be limited to documented performance of particular laboratories.

6.4.3 *Adjustable Guide System Function*—Elliptical trainers that use a mechanical guide position system such as a ratchet, pin or other means to provide limited fixed positions, and that do not actually provide the energy to adjust the incline, are excluded from this test.

6.4.3.1 *Apparatus and Set Up*—The sample shall be set up as described in **5.1**. A combination of vertical displacement and time measuring instruments which yield a combined accuracy of 2.5 mm/s (0.1 in./s) may be used for the velocity measurements. The velocity will be determined by dividing the

displacement by the time required for movement. As an alternate, an instrument that directly measures vertical velocity having the accuracy stated above may be used. The instrumentation is to be fixtured to measure the relative velocity of any entrapment point(s) that occur during actuation of the incline system. A method of applying maximum specified user weight that is independent of angle of inclination must be provided.

6.4.3.2 *Calibration*—Verify that the instrumentation is properly calibrated and yields an accuracy within 2.5 mm/s (0.1 in./s).

6.4.3.3 *Procedure*—Adjust the elliptical trainer to its minimum incline position with no load applied. Operate the incline system to move to the maximum elevation at the fastest rate possible. Once the incline system has reached full inclination, operate the incline control to return the trainer to its minimum inclination at the fastest rate possible. Move one pedal (A) of the elliptical trainer to the most onerous position that could force the incline system to decline. Fix the foot support mechanism of the elliptical trainer to prevent movement, apply a maximum user weight to pedal A, and operate the guide control to return the trainer from its maximum to minimum inclination at the fastest rate possible.

6.4.3.4 *Pass/Fail Criteria*—The maximum measured speed shall not exceed limits set in Specification **F2810**.

6.4.3.5 *Precision and Bias*:

(1) *Precision*—The precision of this test method has not been determined.

(2) *Bias*—The bias of this test method includes quantitative estimates of the uncertainties of the measuring devices, the calibrations of testing equipment and the skill of the operators. At this time, the statements on bias should be limited to documented performance of particular laboratories.

7. Additional Universal Design and Construction Requirements to Test Method **F3022**

7.1 If a conflict exists with the test methods listed in Test Method **F3022**, then the specific requirements listed in 7.17 take precedence over the test methods listed in Test Method **F3022**.

7.2 *Handlebar Height*—This test is a visual and dimensional inspection of the sample to ensure the dimensional compliance of the handlebar height.

7.2.1 *Apparatus and Set Up*—The sample shall be set up as described in **5.1**.

7.2.2 *Calibration*—Verify that the distance measuring equipment is calibrated and accurate to within 1 mm (0.04 in.).

7.2.3 *Procedure*—Measure the height of each handlebar from the floor to the top usable portion of the handlebar. Measure the height of each handlebar from the floor to the lowest usable portion of the handlebar. Verify that the handlebar is available within the specified range.

7.2.4 *Pass/Fail Criteria*—The dimensions of the handlebar height shall conform to dimensional requirements of Section 6.1.1 of Specification **F2810**.

7.2.5 *Precision and Bias*:

7.2.5.1 *Precision*—The precision of this test method has not been determined.

7.2.5.2 *Bias*—The bias of this test method includes quantitative estimates of the uncertainties of the measuring devices, the calibrations of testing equipment, and the skill of the operators. At this time, the statements on bias should be limited to documented performance of particular laboratories.

7.3 *Handlebar Shape*—This test is a visual inspection of the sample to ensure the compliance of the handlebar shape.

7.3.1 *Apparatus and Set Up*—The sample shall be set up as described in 5.1.

7.3.2 *Calibration*—No calibration required. Visual test only.

7.3.3 *Procedure*—Inspect each handlebar to verify that there is a mechanism intended to prevent the hand from slipping off the end.

7.3.4 *Pass/Fail Criteria*—The handlebar shape shall conform to requirements of subsection 6.1.2 of Specification F2810.

7.3.5 *Precision and Bias*:

7.3.5.1 *Precision*—The precision of this test method has not been determined.

7.3.5.2 *Bias*—The bias of this test method includes quantitative estimates of the uncertainties of the measuring devices, the calibrations of testing equipment, and the skill of the operators. At this time, the statements on bias should be limited to documented performance of particular laboratories.

8. Documentation

8.1 *Documentation*—This test is a confirmation that the documentation accompanying the unit meets requirements and the marking on the unit meets the requirements of Specifications F2810 and F2276.

8.1.1 *Apparatus and Set Up*—The sample shall be set up as described in 5.1.

8.1.2 *Calibration*—No calibrations required.

8.1.3 *Procedure*—Examine the documentation provided with the unit. Verify that the documentation is legible. Examine the marking on the elliptical trainers and verify it conforms to the requirements of Specifications F2810 and F2276.

8.1.4 *Pass/Fail Criteria*—Documentation must conform to requirements of Specifications F2810 and F2276.

8.1.5 *Precision and Bias*—No information is presented about either the precision or bias of this test for documentation compliance since the test is non-quantitative.

9. Marking

9.1 Elliptical trainers shall have manufacturer identification affixed to the product in accordance with Specification F2810.

10. Warnings

10.1 *Warning Label Compliance*—This test is a visual confirmation that the test unit is properly labeled.

10.1.1 *Apparatus and Set Up*—The sample shall be set up as described in 5.1.

10.1.2 *Calibration*—No calibration required.

10.1.3 *Procedure*—Inspect the unit for warning labels and tags. Ensure that the labels are firmly affixed to the unit and cannot be readily removed.

10.1.4 *Pass/Fail Criteria*—Labeling must conform to requirements of Specification F2810 and Specification F1749.

10.1.5 *Precision and Bias*—No information is presented about either the precision or bias of the test for warning label compliance since the test result is non-quantitative.

10.2 *Documentation*—This test is a confirmation that the documentation accompanying the unit meets requirements and the marking on the trainer meets the requirements of Specification F2810 and Specification F2276.

10.2.1 *Apparatus and Set Up*—The sample shall be set up as described in 5.1.

10.2.2 *Calibration*—No calibration required.

10.2.3 *Procedure*—Examine the documentation provided with the unit. Verify that the documentation is legible. Examine the marking on the elliptical trainer and verify it conforms to the requirements of Specification F2810 and Specification F2276.

10.2.4 *Pass/Fail Criteria*—Documentation must conform to requirements of Specification F2810 and Specification F2276.

10.2.5 *Precision and Bias*—No information is presented about either the precision or bias of this test for documentation compliance since the test is non-quantitative.

11. Certification

11.1 These test methods permit self-certification. It is recommended that each manufacturer employ an independent laboratory to evaluate and validate that their test procedures and methodologies conform and comply with these test methods and Specification F2810.

12. Report

12.1 *Record of Tests*—Maintain complete test records and test summary reports for all testing, whether performed by the manufacturer or an independent laboratory. The records can be stored on paper, electronically, and/or on photographs. A copy of the test summary must be kept by the laboratory that performed the test for a minimum of five years from the date of the test and by the manufacturer for a minimum of five years past the end of the production of the model tested. The summary shall include the signature of the technician(s) performing the tests and a management representative of the laboratory performing the test. The test summary shall include the following information:

12.1.1 Manufacturer's name and location,

12.1.2 Information provided by the manufacturer to accurately identify the configuration of, and specific unit provided to, the testing agency,

12.1.3 Dates over which the tests were conducted,

12.1.4 Name and location of the testing laboratory, if different from the manufacturer, and

12.1.5 Summary and results of each test performed including method and apparatus used. This shall include what the desired requirement was and whether the test sample met that parameter or failed. If the test requires a specific number of cycles to be met, then the report must include the number of cycles actually conducted. If the trainer fails to meet a parameter, then that failure must be noted in clear and accurate terms to enable a reader of the report to understand at a later date what transpired.

13. Keywords

13.1 elliptical trainer; fitness equipment; foot support; handlebar

APPENDIX

(Nonmandatory Information)

X1. ADDITIONAL READING

X1.1 *European Standards*: EN 957-1 Stationary Training Equipment—Part 1: General Safety Requirements and Test Methods

EN 957-9 Stationary Training Equipment—Part 9: Elliptical Trainers, Additional Specific Safety Requirements and Test Methods

ASTM International takes no position respecting the validity of any patent rights asserted in connection with any item mentioned in this standard. Users of this standard are expressly advised that determination of the validity of any such patent rights, and the risk of infringement of such rights, are entirely their own responsibility.

This standard is subject to revision at any time by the responsible technical committee and must be reviewed every five years and if not revised, either reapproved or withdrawn. Your comments are invited either for revision of this standard or for additional standards and should be addressed to ASTM International Headquarters. Your comments will receive careful consideration at a meeting of the responsible technical committee, which you may attend. If you feel that your comments have not received a fair hearing you should make your views known to the ASTM Committee on Standards, at the address shown below.

This standard is copyrighted by ASTM International, 100 Barr Harbor Drive, PO Box C700, West Conshohocken, PA 19428-2959, United States. Individual reprints (single or multiple copies) of this standard may be obtained by contacting ASTM at the above address or at 610-832-9585 (phone), 610-832-9555 (fax), or service@astm.org (e-mail); or through the ASTM website (www.astm.org). Permission rights to photocopy the standard may also be secured from the Copyright Clearance Center, 222 Rosewood Drive, Danvers, MA 01923, Tel: (978) 646-2600; <http://www.copyright.com/>