



Standard Specification for Bicycle Grips¹

This standard is issued under the fixed designation F2793; the number immediately following the designation indicates the year of original adoption or, in the case of revision, the year of last revision. A number in parentheses indicates the year of last reapproval. A superscript epsilon (ϵ) indicates an editorial change since the last revision or reapproval.

INTRODUCTION

This specification defines a set of physical characteristics for Bicycle Grips and End Closures. One intent of this specification is to define certain dimensions of Bicycle Grips and End Closures applied to tubular handlebars mounted on bicycles designed for cyclists who are 12 years of age or younger. The second intent of this specification is to test the durability of the ends of the Bicycle Grips and End Closures for all bicycles where the tubular handlebar end axes are oriented within 60° of parallel to the axle axis of the steering wheel. This second intent would apply to the “BMX” and “Mountain” style tubular handlebar examples illustrated in Fig. 1, and does not apply to the “Drop” (also known as road race) style shown in the same figure.

1. Scope

1.1 This specification establishes a minimum outer diameter for the Bicycle Grip or End Closure, and the method for determining if the grip or End Closure meets the diameter.

1.2 This specification checks the following characteristics:

- 1.2.1 Bicycle Grip outer diameter,
- 1.2.2 Bicycle Grip or End Closure diameter or both, and
- 1.2.3 Bicycle Grip or End Closure retention or both.

1.3 This specification establishes testing requirements for the durability of Bicycle Grips and End Closures. It represents a performance standard and is not intended to dictate the design, materials, or construction of those closures.

1.4 *Units*—The values stated in SI units are to be regarded as the standard. The values in parentheses are for information only.

1.5 *This standard does not purport to address all of the safety concerns, if any, associated with its use. It is the responsibility of the user of this standard to establish appropriate safety and health practices and determine the applicability of regulatory limitations prior to use.*

2. Referenced Documents

- 2.1 *ASTM Standards*:²
[F2043 Classification for Bicycle Usage](#)

¹ This test method is under the jurisdiction of ASTM Committee F08 on Sports Equipment, Playing Surfaces, and Facilities and is the direct responsibility of Subcommittee F08.10 on Bicycles.

Current edition approved Sept. 1, 2014. Published September 2014. DOI: 10.1520/F2793-14.

² For referenced ASTM standards, visit the ASTM website, www.astm.org, or contact ASTM Customer Service at service@astm.org. For *Annual Book of ASTM Standards* volume information, refer to the standard's Document Summary page on the ASTM website.

- 2.2 *Other Standards*:³
[SAE J526:2000 Welded Low-Carbon Steel Tubing](#)

3. Terminology

3.1 The term *bicycle* is defined in Classification [F2043](#).

3.2 *Definitions of Terms Specific to This Standard*:

3.2.1 *bicycle grip, n*—parts on the handlebar that are meant to be grasped to allow for control and comfort while steering and operating the bicycle.

3.2.1.1 *Discussion*—The Bicycle Grip may or may not include a portion or all of the End Closure (see **end closure**).

3.2.2 *bicycle leg maximum, n*—a distance measured from crank rotation axis to the top center of the seat, with the seat positioned at the bicycle manufacturer's maximum allowed seat adjustment away from the crank axis, [Fig. 2](#).

3.2.3 *end closure, n*—end cap, fitting, grip, device, or combination of parts intended to close the end of a tubular bicycle handlebar, [Fig. 3](#).

3.2.4 *grip diameter, n*—diameter of the Bicycle Grip where the hand is placed for normal riding.

3.2.5 *grip end diameter, n*—diameter of the Bicycle Grip end (largest diameter within 40 mm of the handlebar end).

3.2.6 *handlebar coupon, n*—welded cold-drawn SAE 1018 steel tube with deburred edges, used to imitate a handlebar in the End Closure punch-out test, [Fig. 4](#). Material shall meet SAE J526 specifications.

³ Available from SAE International (SAE), 400 Commonwealth Dr., Warrendale, PA 15096-0001, <http://aerospace.sae.org>.

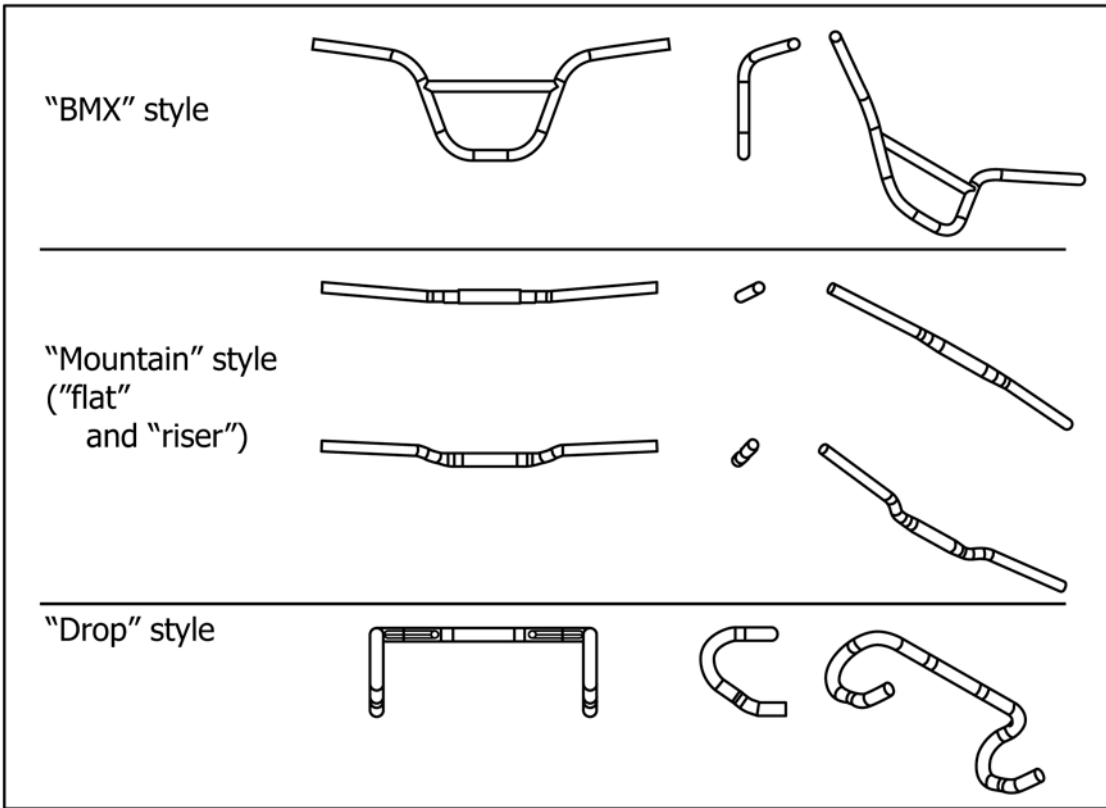

FIG. 1 Some Examples of Tubular Handlebar Styles

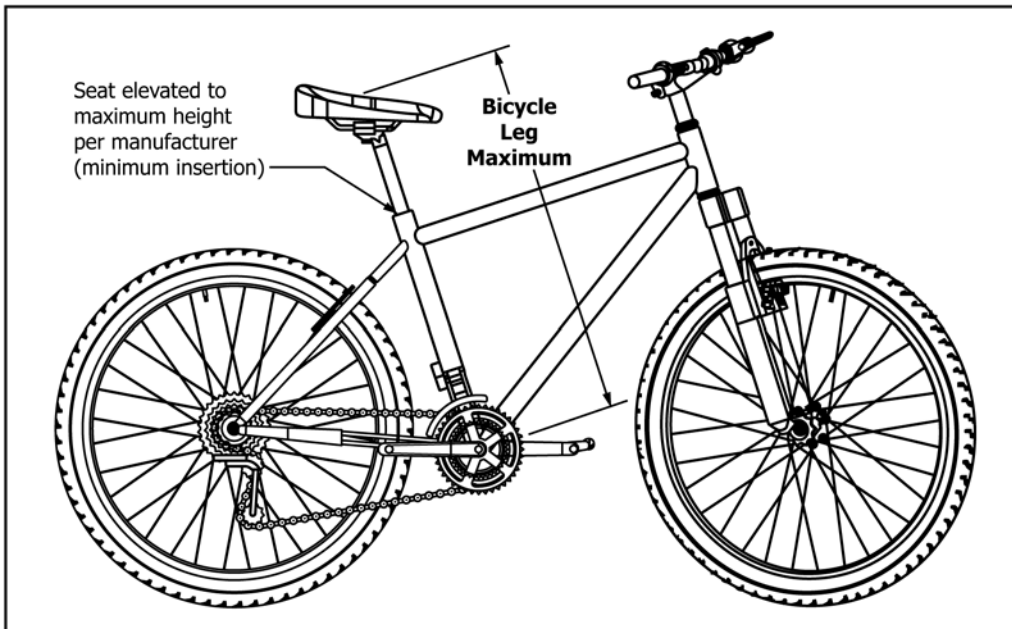

FIG. 2 Bicycle Leg Maximum

3.2.7 *OEM bar, n*—the original equipment manufacturer (OEM) handlebar as supplied, or as specified, with a complete bicycle intended to be used with the Bicycle Grip or End Closure, or both.

3.2.8 *punch out, v*—when a handlebar penetrates the End Closure exposing the end of a tubular bicycle handlebar.

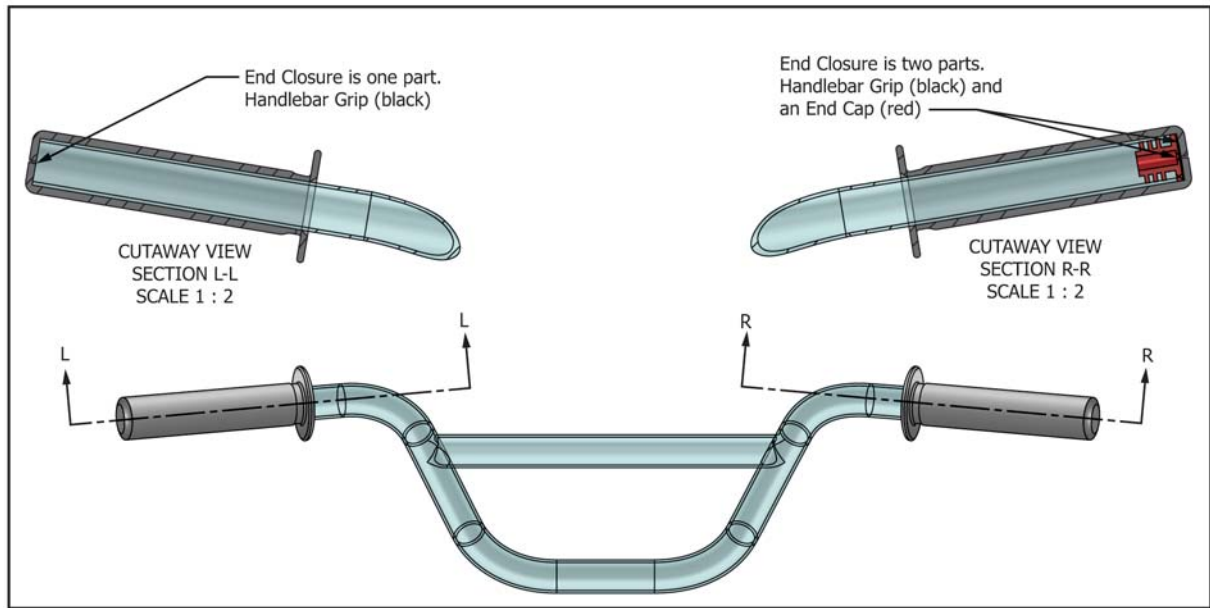

FIG. 3 Some Examples of End Closure

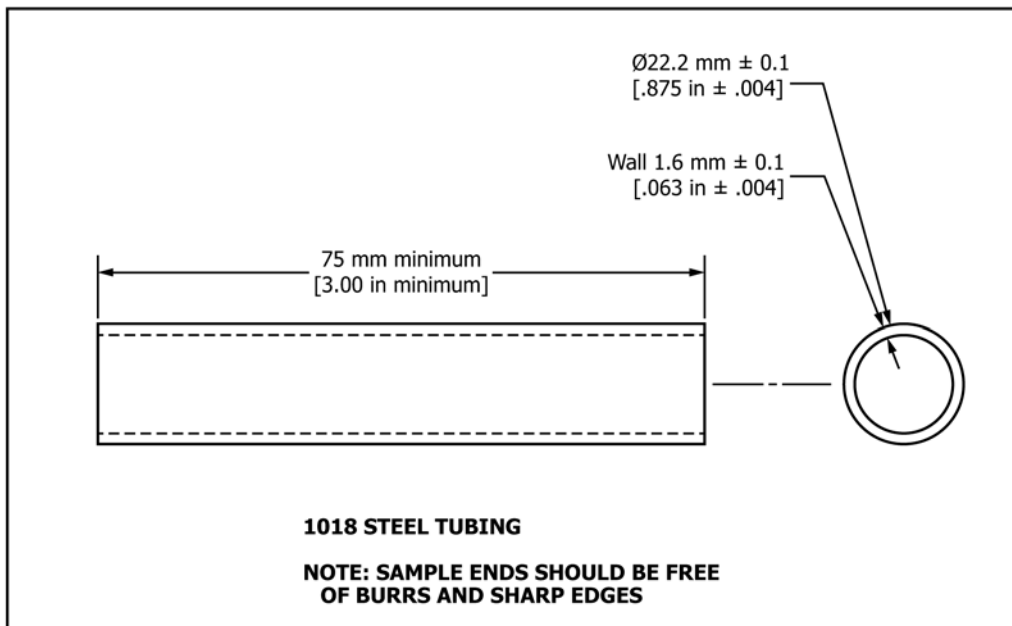

FIG. 4 Handlebar Coupon

3.2.9 *side extending handlebar, n*—a tubular handlebar frame whose tube axis at the location of the Bicycle Grip or End Closure, is oriented within a conical region, 60° of parallel to the direction defined by the axle axis of the steering wheel, when properly mounted on the bicycle.

3.2.10 *smooth, adj*—free from burrs, abrupt indentations, or sharp edges.

4. Performance Requirements

4.1 The following performance requirements are for Bicycle Grips and End Closures to be installed on a Side Extending Handlebar.

4.1.1 *Retention*—The Bicycle Grips and End Closures shall be secure against a removal force of no less than 66.8 N (15 lbf). (Refer to test method 9.1.)

4.1.2 *Punch-Out*—The End Closure shall withstand a drop of 100 mm (3.94 in.) ten times loaded with a mass of 10 kg (22 lb) without having more than 270° of End Closure punched out by the OEM bar or Handlebar Coupon. (Refer to the test method described in 9.2.)

4.1.3 *Dimensions*—For bicycles with a Bicycle Leg Maximum distance less than or equal to 500 mm (19.7 in.), the appropriate dimensions of the Bicycle Grip and End Closure shall be determined by use of the go/no-go gauge as described in Section 9.

TEST METHODS

5. Summary of Test Method

5.1 *End Closure Retention Test*—Retention test shall be performed to guarantee a minimal removal force required for End Closure.

5.2 *Impact Testing of Handlebar End Closures*—Impact testing shall be performed to identify the possibility of Punch Out of the End Closure.

5.3 *Measuring Grip Diameter*—The Bicycle Grip shall be measured for outer diameter where the hand is placed for normal riding/steering.

5.4 *Measuring Grip End Diameter*—The Bicycle Grip end shall be measured for overall diameter.

6. Significance and Use

6.1 These tests are intended to address the Bicycle Grip with regard to steering control, durability and potential reduction in injury during an accident.

7. Apparatus

7.1 *Requirements for Punch-Out Test (See Fig. 4 and Fig. 7):*

7.1.1 The Punch-Out test is to be performed on an End Closure mounted on the OEM bar. If an OEM bar is not specified by the manufacturer use a Handlebar Coupon.

7.1.1.1 If the OEM bar is being tested, remove all attachments to the handlebar that are not Bicycle Grip or End Closure

components. The OEM bar shall be cut to utilize one complete end, including grip. The OEM bar shall be discarded after ten (10) drops.

7.1.1.2 If the Handlebar Coupon is being used for the test, the end of the Handlebar Coupon inserted into the grip should be smooth. After ten (10) drops are completed, the used Handlebar Coupon shall be discarded.

7.1.2 The punch-out test fixture is a free-falling mass guided, as with the use of a slide rail or rails, to maintain orientation during the drop; and, with the ability to be raised and dropped from 100 mm (3.94 in.) onto a defined surface with a Bicycle Grip vertically attached. Upon drop, the End Closure will contact the defined surface first.

7.1.3 Smooth contact surface should be made of 1018 steel with a minimum thickness of 6 mm (0.24 in.).

7.2 *Requirements for Measuring Grip Diameter and Grip End Diameter*—The grip shall be measured using a go/no-go gauge (see Fig. 5) to determine acceptability of Grip Diameter and Grip End Diameter.

7.2.1 A = 35 mm (1.38 in.).

8. Materials and Conditioning

8.1 Tests are to be performed at room temperature between 18 to 35°C (64.4 to 95°F).

8.2 All tests shall be performed on production-ready parts and installed as normal for production.

9. Procedure

9.1 *End Closure Retention:*

9.1.1 The End Closure shall be installed on the OEM bar in a fashion representative of the state of production.

9.1.2 Apply a force of 67 N (15 lbf) to the End Closure in the direction of removal. Maintain the force for one minute.

9.1.3 The End Closure shall not be removed from the handlebar.

9.2 *End Closure Punch-Out Test:*

9.2.1 Install End Closure onto OEM bar or Handlebar Coupon to form the test sample. The OEM bar may be cut to utilize no less than 75 mm of the straight outboard end of the handlebar tube. The Bicycle Grip may be cut to utilize no less

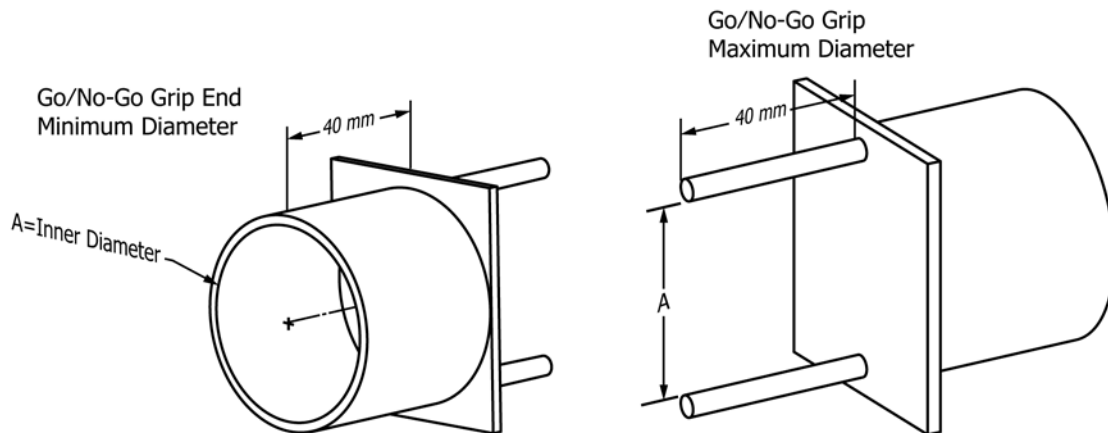

FIG. 5 Design for Go/No-Go Gauge

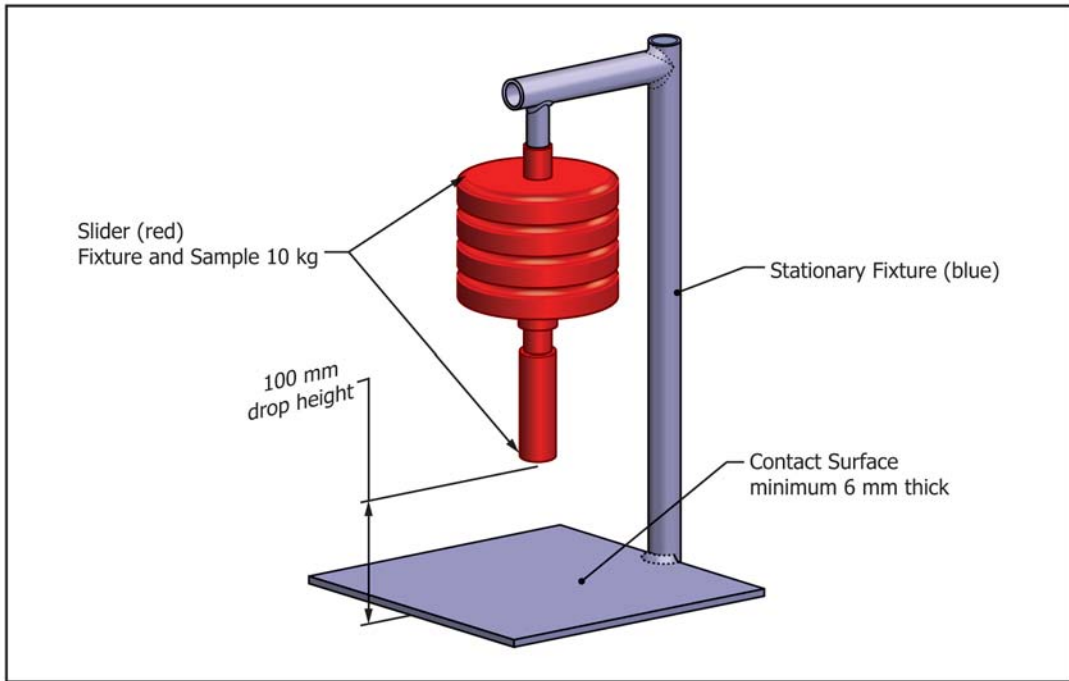

FIG. 6 Example Punch-Out Test Fixture

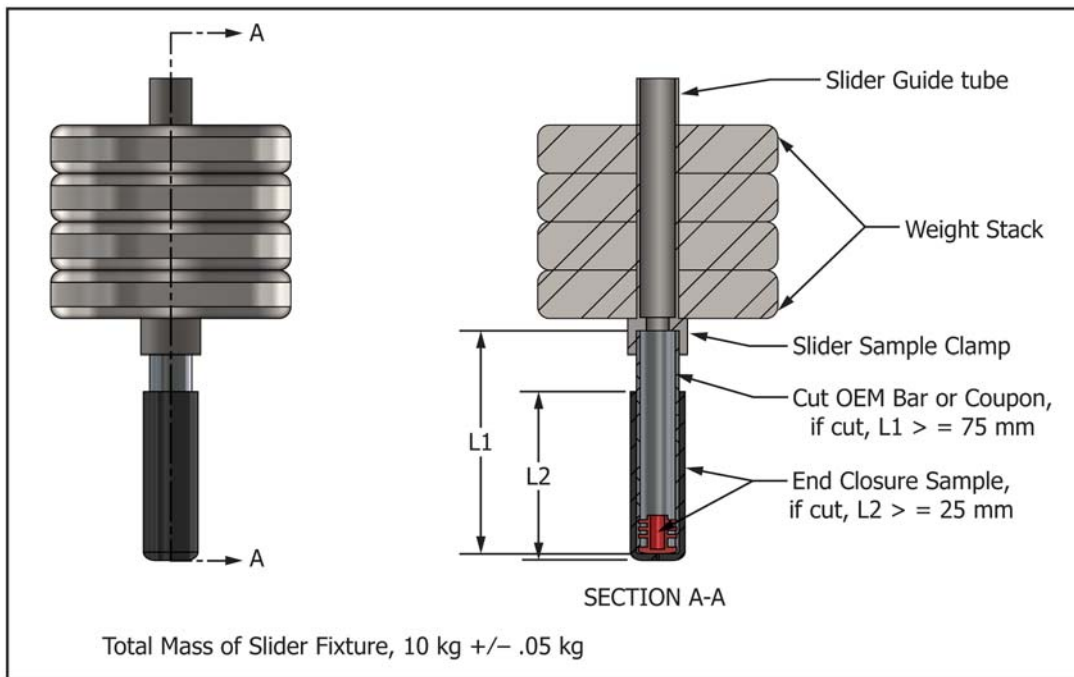

FIG. 7 Example Punch-Out Test Fixture

than 25 mm of the outboard end, see the example shown in Fig. 7. The total weight of the test sample shall be no more than 180 g (0.4 lb).

9.2.2 Verify contact plate is smooth.

9.2.3 Attach the OEM bar, or Handlebar Coupon, and End Closure to the test fixture with a combined weight of 10 kg (22 lb) \pm 50 g. The longitudinal axis of the Handlebar Coupon or OEM bar must be perpendicular to the contact plate.

9.2.4 Raise the test fixture so that the lowest point of the End Closure sample is 100 mm above the contact plate. Release the test fixture allowing it to freefall until the end of the End Closure sample strikes the contact plate. Verify the velocity at moment of contact is a minimum of 1.33 m/s, or 95 % of 1.40 m/s (100 mm free fall).

9.2.4.1 Repeat 9.2.4 nine times, for a total of ten impacts.

9.2.5 Examine the end of the End Closure.

9.2.5.1 If the End Closure has more than 270° of handlebar exposed, as determined by an unaided eye, the End Closure has failed the test. Otherwise the test is passed.

9.3 *Grip Diameter:*

9.3.1 The Bicycle Grip shall be installed on the OEM bar in a fashion representative of a production state.

9.3.2 Using the two-pronged end of the go/no-go gauge, straddle the prongs over the midpoint of the Bicycle Grip (that is, at the point one-half along the length of the grip) making note if any resistance is encountered. If the Bicycle Grip fits between the prongs with no resistance, the Bicycle Grip diameter is acceptable. If the Bicycle Grip fails to fit between the prongs or requires any applied force to fit, rotate the gauge around the Bicycle Grip in either direction until the Bicycle Grip presents the smallest dimension to the prongs. If the Bicycle Grip still does not fit or resistance is encountered, the Bicycle Grip diameter is unacceptable (see Fig. 8).

9.4 *Grip End Diameter:*

9.4.1 The grip shall be installed on the OEM bar in a fashion representative of the state of production.

9.4.2 Using the cylindrical end of the go/no-go gauge, verify that the cylinder does not fit over the end of the Bicycle Grip. If the cylinder does not completely fit (to the full depth of go/no-go gauge) over the Bicycle Grip without the use of force, the Bicycle Grip end diameter is acceptable. If the

cylinder fits completely over the end of the grip with no resistance, the Bicycle Grip end diameter is unacceptable (see Fig. 9).

10. Report

- 10.1 A test report shall be prepared with the following:
 - 10.1.1 Applicable test method specification.
 - 10.1.2 The date and location of the test.
 - 10.1.3 The name of the test facility conducting the test.
 - 10.1.4 Photographs of test setup.
 - 10.1.5 Photographs or description, or both, of all parts tested; OEM bar or Handlebar Coupon, Bicycle Grip, or End Closure, or a combination thereof. These should include Manufacturer name and Part number.
 - 10.1.6 Results of all testing within this specification.

11. Precision and Bias

11.1 *Precision and Bias*—The test methods in this standard establish minimum consumer performance requirements for an unlimited variety of material and design approaches. These are pass or fail tests for which numerical result variations are not significant.

12. Keywords

- 12.1 bicycle; end closure; grip diameter; grip end diameter; grips; handlebar

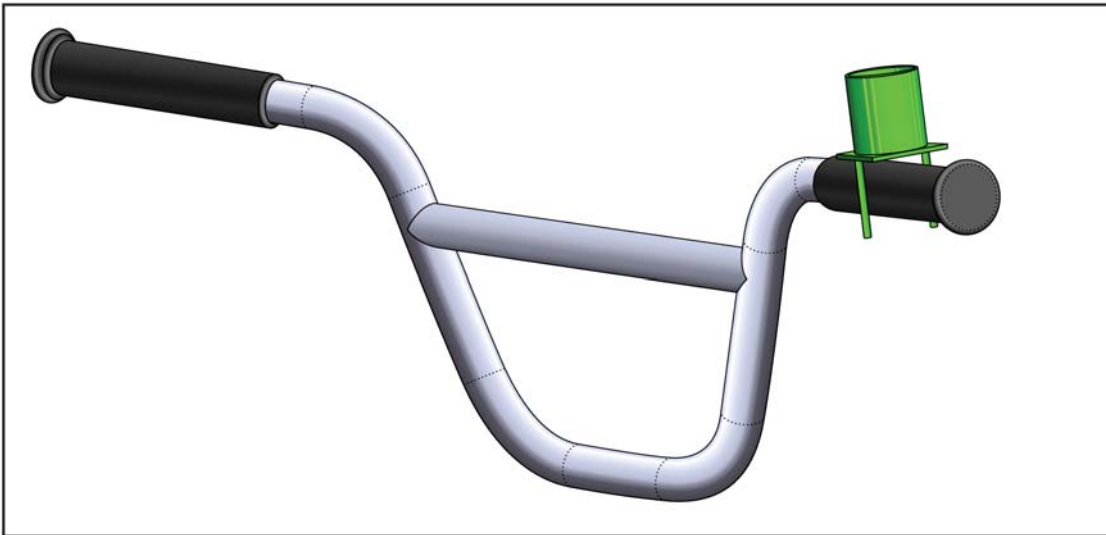

FIG. 8 Grip Diameter

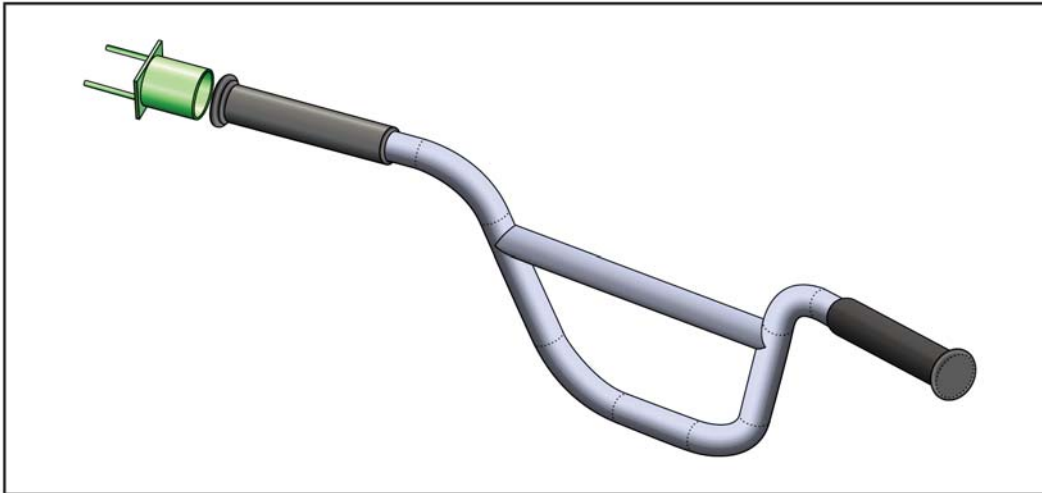

FIG. 9 Grip End Diameter

ASTM International takes no position respecting the validity of any patent rights asserted in connection with any item mentioned in this standard. Users of this standard are expressly advised that determination of the validity of any such patent rights, and the risk of infringement of such rights, are entirely their own responsibility.

This standard is subject to revision at any time by the responsible technical committee and must be reviewed every five years and if not revised, either reapproved or withdrawn. Your comments are invited either for revision of this standard or for additional standards and should be addressed to ASTM International Headquarters. Your comments will receive careful consideration at a meeting of the responsible technical committee, which you may attend. If you feel that your comments have not received a fair hearing you should make your views known to the ASTM Committee on Standards, at the address shown below.

This standard is copyrighted by ASTM International, 100 Barr Harbor Drive, PO Box C700, West Conshohocken, PA 19428-2959, United States. Individual reprints (single or multiple copies) of this standard may be obtained by contacting ASTM at the above address or at 610-832-9585 (phone), 610-832-9555 (fax), or service@astm.org (e-mail); or through the ASTM website (www.astm.org). Permission rights to photocopy the standard may also be secured from the Copyright Clearance Center, 222 Rosewood Drive, Danvers, MA 01923, Tel: (978) 646-2600; http://www.copyright.com/