



Standard Consumer Safety Specification for Constant Air Inflatable Play Devices for Home Use¹

This standard is issued under the fixed designation F2729; the number immediately following the designation indicates the year of original adoption or, in the case of revision, the year of last revision. A number in parentheses indicates the year of last reapproval. A superscript epsilon (ϵ) indicates an editorial change since the last revision or reapproval.

1. Scope

1.1 This consumer safety specification establishes performance requirements, test methods, and labeling requirements to promote the safe use of constant air inflatable play devices for private home use. Constant air inflatable play devices for home use that incorporate water play features and do not retain water are not considered as portable pools. Constant air inflatable play devices for home use that incorporate water play features and are intended to hold water for wading or water recreational purposes are applicable to the marking and labeling section of this specification. This specification does not apply to stored air inflatable swimming pools or sealed inflatable devices whether or not they retain water.

1.2 This consumer safety specification provides safety requirements for various types of constant air inflatable play devices for home use intended for children aged from two (2) years through twelve (12) years.

1.3 This consumer safety specification is intended to reduce the risk of death and minimize serious injury to children resulting from use of constant air inflatable play devices for home use.

1.4 No constant air inflatable play devices for home use produced after the approval date of this consumer safety specification shall, either by label or other means, indicate compliance with this specification unless it conforms to all requirements contained herein. The following statement is suggested for use in identifying a product that conforms to all requirements in this specification:

1.4.1 “This product conforms to ASTM F2729, Standard Consumer Safety Specification for Constant Air Inflatable Play Device for Home Use.”

1.5 The test values and dimensions stated in SI units are to be regarded as standard. The inch-pound values in parenthesis, when given, are for information only.

1.6 *General Measures, Tolerances, and Conversions:*

1.6.1 The general tolerances for this specification (unless otherwise specified) are as follows:

¹ This specification is under the jurisdiction of ASTM Committee F15 on Consumer Products and is the direct responsibility of Subcommittee F15.61 on Constant Air Inflatable Play Devices for Home Use.

Current edition approved Sept. 1, 2012. Published November 2012. DOI: 10.1520/F2729-12.

Dimension Tolerance

$X \pm 12.7$ mm ($X \pm 0.5$ in.)

$X.X \pm 1.27$ mm ($X.X \pm 0.05$ in.)

$X.XX \pm 0.127$ mm ($X.XX \pm 0.005$ in.)

These tolerances still apply to a dimension even when terms like greater than, less than, minimum, or maximum are used.

1.6.2 The values stated in SI units are to be regarded as standard. The values given in parentheses are mathematical conversions to inch-pound units that are provided for information only.

1.6.3 The conversion factor from SI to inch-pound units is 25.4 mm = 1 in., and 0.45359 kg = 1 lb.

1.7 The following precautionary caveat pertains only to the test methods portion of this consumer safety specification: *This standard does not purport to address all of the safety concerns, if any, associated with its use. It is the responsibility of the user of this standard to establish appropriate safety and health practices and determine the applicability of regulatory limitations prior to use.*

2. Referenced Documents

2.1 *ASTM Standards:*²

[D1683 Test Method for Failure in Sewn Seams of Woven Apparel Fabrics](#)

[D2240 Test Method for Rubber Property—Durometer Hardness](#)

[D5034 Test Method for Breaking Strength and Elongation of Textile Fabrics \(Grab Test\)](#)

[F963 Consumer Safety Specification for Toy Safety](#)

2.2 *Federal Regulations:*³

[16 CFR 1303 Ban of Lead-Containing Paint and Certain Consumer Products Bearing Lead Containing Paint](#)

[16 CFR 1500 Federal Hazardous Substances Act regulations, including sections:](#)

[1500.44 Method for Determining Extremely Flammable and Flammable Solids](#)

² For referenced ASTM standards, visit the ASTM website, www.astm.org, or contact ASTM Customer Service at service@astm.org. For *Annual Book of ASTM Standards* volume information, refer to the standard's Document Summary page on the ASTM website.

³ Available from U.S. Government Printing Office Superintendent of Documents, 732 N. Capitol St., NW, Mail Stop: SDE, Washington, DC 20401, <http://www.access.gpo.gov>.

- 1500.48 Technical Requirements for Determining a Sharp Point in Toys and Other Articles Intended for Use by Children Under 8 Years of Age
- 1500.49 Technical requirements for Determining a Sharp Metal or Glass Edge in Toys or in Other Articles Intended for Use by Children Under 8 Years of Age
- 1500.50 Test Methods for Simulating Use and Abuse of Toys and Other Articles Intended for Use by Children
- 1500.52 Test Methods for Simulating Use and Abuse of Toys and Other Articles Intended for Use Over 18 But Not Over 36 Months of Age
- 1500.53 Test Methods for Simulating Use and Abuse of Toys and Other Articles Intended for Over 36 But Not Over 96 Months of Age
- 1500.87 Children’s Products Containing Lead: Inaccessible Component Parts
- 1500.88 Exemptions from Lead Limits Under Section 101 of the Consumer Product Safety Improvement Act for Certain Electronic Devices
- 1500.91 Determinations Regarding Lead Content for Certain Materials or Products Under Section 101 of the Consumer Product Safety Improvement Act
- 16 CFR 1501 Method for Identifying Toys and Other Articles Intended for Use by Children Under 3 Years of Age Which Present Choking, Aspiration, or Ingestion Hazards Because of Small Parts
- 16 CFR 1505 Requirements for Electrically Operated Toys or Other Electrically Operated Articles Intended for Use By Children
- 2.3 *Other:*
- ANSI Z535.4 Product safety signs and labels⁴
- Beaufort Wind Force Scale
- CPAI 84 A Specification for Flame-Resistant Materials used in Camping Tentage
- UL 507 UL Standard for Safety Electric Fans⁵

3. Terminology

3.1 Definitions of Terms Specific to This Standard:

- 3.1.1 *blower*, *n*—a powered fan used to inflate the inflatable device.
- 3.1.2 *blower tube*, *n*—the part of the inflatable device to which the blower is connected to the inflatable device for the purpose of inflation.
- 3.1.3 *constant air inflatable play device*, *n*—a structure relying on a continuous supply of air pressure to maintain its shape, on or in which users play.
 - 3.1.3.1 *Discussion*—This term constant air inflatable play device refers to the simplified term “inflatable device” throughout the remainder of the document.
- 3.1.4 *critical fall height*, *n*—the upper limit of all free heights of fall, for which the surface provides adequate levels of impact attenuation.

3.1.5 *flaming debris*, *n*—material that becomes detached from the sample during the test procedure and continues to flame as it falls.

3.1.6 *free height of fall*, *n*—the greatest distance from the clearly intended body support to the fall zone below.

3.1.7 *grounding*, *n*—contact with the underlying surface on which the inflatable device sits.

3.1.8 *load bearing components*, *n*—those components intended to bear the mass of the users. Examples of these include but are not limited to: surfaces intended to be bounced on, slides, steps, ladders, footholds, gripping and grasping devices, climbing devices, transition platforms, containment walls that enclose a surface intended to be bounced on, ramps, tunnels, pools, and anchoring devices.

3.1.9 *molten drips*, *n*—falling droplets of molten material.

3.1.10 *non-climbable net or mesh*, *n*—a fabric or synthetic material that is not intended to be climbed.

3.1.11 *non-load bearing components*, *n*—those components not intended to bear the mass of the users. Examples of these include but are not limited to: decorative items such as flags, areas under bouncing surfaces, air baffles, blower tubes, roof, and un-inflated areas.

3.1.12 *non-rigid*, *n*—any material having hardness below 70 Shore A scale durometer, as measured by the latest revision of Test Method D2240.

3.1.13 *open side*, *n*—any external side of an inflatable device with no containment wall.

3.1.14 *platform*, *n*—any surface on which users stand, sit or traverse.

3.1.15 *playing area*, *n*—any part or area of the inflatable device that is intended solely for the purpose of taking part in the activity for which the inflatable device is designed.

3.1.16 *ramp*, *n*—an inclined section aiding the access and egress of users into and out of the playing area.

3.1.17 *rigid*, *n*—any material having hardness above or equal to 70 Shore A scale durometer, as measured by the latest revision of Test Method D2240.

3.1.18 *run-out section*, *n*—intended deceleration zone at the bottom of a slide.

3.1.19 *sealed inflatable device*, *n*—a structure or device on or in which users play that is inflated by means of air and, having achieved the design pressure, is sealed and does not require additional continuous inflation.

3.1.20 *toy accessory*, *n*—an article that provides certain play value separate from, but attached to or sold with, the inflatable device intended for playtime use by a child.

3.1.21 *use zone*, *n*—an area beneath and immediately adjacent to the inflatable device that is designed for unrestricted circulation around the inflatable device.

4. Calibration and Standardization

4.1 Unless otherwise noted, the inflatable device shall be completely assembled in accordance with the manufacturer’s instructions.

⁴ Available from American National Standards Institute (ANSI), 25 W. 43rd St., 4th Floor, New York, NY 10036, <http://www.ansi.org>.

⁵ Available from Underwriters Laboratories (UL), 333 Pfingsten Rd., Northbrook, IL 60062-2096, <http://www.ul.com>.

4.2 The inflatable device to be tested shall be inflated at an ambient temperature of $23 \pm 5^\circ\text{C}$ ($73 \pm 9^\circ\text{F}$) for at least one hour prior to testing. Testing shall be conducted within this temperature range.

4.3 All structural testing required by this specification shall be conducted on the same unit.

5. General Requirements

5.1 There shall be no hazardous sharp points or edges as defined in 16 CFR 1500.48 and 16 CFR 1500.49, before or after the inflatable device has been tested to this consumer safety specification.

5.2 There shall be no small parts as defined in 16 CFR 1501 before testing or liberated as a result of testing to this specification for inflatable devices intended for children under 36 months.

5.3 All surface coatings on the inflatable device shall comply with the requirements of 16 CFR 1303 and the Heavy Metals requirements of Consumer Safety Specification F963.

5.4 Accessible component parts (before and after Use-and-Abuse testing described at 16 CFR 1500.50–53 and 16 CFR 1500.87(h)) shall not contain lead or lead compounds in which the lead content (calculated as lead metal [Pb]) is in excess of 100 ppm.

5.5 The inflatable device shall be designed to allow natural air circulation and lines of visibility between users and persons supervising when evaluated according to 5.5.1.

5.5.1 Each 0.057 m^3 (2 ft^3) section of the playing area must be visible from the outer perimeter, in a minimum of two locations that are spaced at least 2.75 m (9 ft) apart measured at 1.5 m (5 ft) above the ground level.

5.6 *Fabric Strength*—Fabrics shall be of adequate tear and tensile strength for the weight of the intended users and have sufficient air retention abilities to enable the inflatable device, when pressurized utilizing the manufacturer’s blower, to resume its intended shape after distortion under load. Fabrics used in those areas of the inflatable device that are load-bearing shall have the following as a minimum:

5.6.1 Minimum tear strength of 80% of its original tear strength when tested in accordance with Test Method D5034 after being subjected to 100 h of conditioning set forth in CPAI 84, Section 4.2.2.3.

5.6.2 Minimum fabric tensile strength of 535 N (120 lb) when tested in accordance with Test Method D5034.

5.6.3 Minimum seam strength of 380 N (85 lb) when tested in accordance with Test Method D1683.

5.6.4 Non-load bearing components are exempt from these requirements.

5.7 *Flamability*—Flexible fabric-like materials used in the inflatable device shall be tested according to a modified version of the flammability of solids test method in 16 CFR 1500.44, as follows:

5.7.1 Cut test samples with dimensions of at least 610 by 100 mm (24 by 4 in.) from each accessible material available on the inflatable device. Each test sample shall be made of one material. Where possible, ensure that the sample does not include seamed edges. As seams modify the rate of spread of flame, they shall be placed in the upper part of the sample holder. If there is insufficient material to make a full sample as described above, it is acceptable to use two equal pieces of the same material with dimensions of 305 by 100 mm (12 by 4 in.) so that when they overlap, a full sample of at least 610 by 100 mm (24 by 4 in.) is obtained. In order to ensure that there is no gap at the overlap, it is acceptable to use staples to secure the joint.

5.7.2 As the rate of flame spread can be different with the direction of the fabric-like material, where there is enough material, cut the test sample with the length corresponding to the vertical direction of the inflatable when in use.

5.7.3 Place the sample in an appropriate sample holder, slightly tensioned to avoid creases, waving or curling. Both surfaces of the same material shall be tested separately.

5.7.4 Position the sample holder at a 45° (0.785 rad) angle.

5.7.5 Apply the test candle flame to the bottom edge of the test sample.

5.7.6 The rate of flame spread shall not exceed 25.4 mm/s (1.0 in./s) or shall self-extinguish. There shall be no flaming debris or molten drips.

5.8 *Solids Flammability*—Solid materials used in the inflatable device shall be tested according to the flammability of solids test method in 16 CFR 1500.44.

5.9 *Non-Climbable Netting or Mesh*—Where used for containment or retention, the netting or mesh shall meet the strength requirements described in 5.6. The mesh size shall be small enough to prevent the 12 mm (0.5 in.) rod from passing through when tested as follows:

5.9.1 *Test Procedure for Non-Climbable Net or Mesh*—Align the probe (see Fig. 1) perpendicular to the net or mesh. Push the probe, with a 4.45 N (1.0 lbf), round end first, into the net or mesh. A net or mesh is non-climbable if the probe enters equal to or less than 12 mm (0.5 in.) deep.

5.10 *Rope Climber Nets*—Rope climber nets shall be securely attached at both ends to the inflatable device to prevent

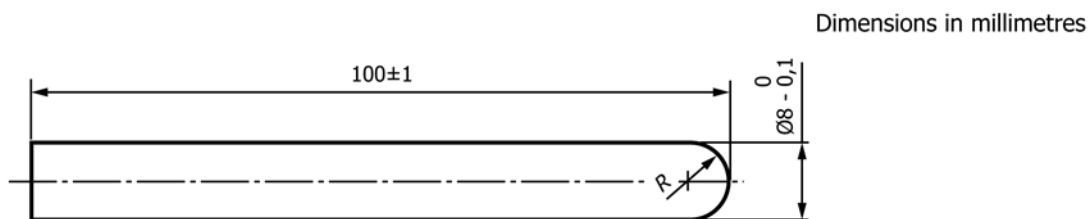

FIG. 1 Non-Climbable Net or Mesh Probe

lifting by users. The rope shall be a minimum of 12 mm (0.5 in.) in diameter and securely knotted at intersections so that the knots do not slip when subjected to a 140 kg (308 lb) load or three times the manufacturer’s maximum intended weight of the user, whichever is greater.

5.11 Climber nets shall comply with head and neck entrapment requirements in section 6.4.

5.12 *Climbing Ropes*—Climbing ropes shall be anchored at both ends and not be capable of being looped back on itself, creating an inside loop perimeter greater than 125 mm (5 in.).

5.13 *Zippers*—Zippers shall withstand the air pressure generated within the inflatable device. If zippers are used, they shall be easy to use from both sides. Zippers used for deflation purposes shall have the zipper pull covered from view (for example, by a flap or pocket).

6. Performance Requirements

6.1 Anchoring:

6.1.1 Sufficient anchor points shall be provided and located under the load and wind velocities described below to enable stability and restraint to be maintained under the manufacturer’s recommended maximum loading condition and wind velocity. Anchoring for inflatable devices for outdoor use shall be designed to withstand a minimum Beaufort scale 6 wind speed (11.1 m/s).

6.1.2 The number of anchor points required shall be calculated, independently for each side, using the following formula and values below. In all cases, there shall be a minimum of two anchor points per side. First calculate the force on each side using:

$$F = C_w \frac{\rho}{2} V^2 A \quad (1)$$

where:

- F = force on the side,
- C_w = wind coefficient,
- ρ = density of air,
- V = maximum wind speed, and
- A = area of exposed surface.

Using the following values:

- C_w = 1.5
- ρ = 1.24 kg/m³
- V = calculation wind velocity in m/s (Beaufort scale 6 = 11.1 m/s)
- A = area of exposed surface (to be determined by measurement and calculation)

The number of anchor points required on this side shall be calculated by dividing the force, F , by the force each anchor system shall be engineered to withstand, 1600 N (360 lbf), and multiplying by a safety factor of 1.5. The value shall be rounded up to the next integer. The calculation shall be repeated for each side.

The number of anchor-points required on each side is:

$$N = \frac{F}{1600N} \times 1.5 \text{ rounded up where } 1.5 \text{ is a safety factor.}$$

This calculation shall be repeated for each side.

NOTE 1—Corner anchors count as one half of an anchor on each side towards the total.

6.1.3 Stakes that are used as an anchor system shall be designed and installed so that top of the stake is flush to or below the ground, if accessible to a user falling onto the stake.

6.1.4 Where the inflatable device is not secured with ground anchor stakes (such as a ballast bag, sandbox, or other means), the total anchor system shall be designed and detailed to withstand the same forces as though it was secured with ground anchor stakes.

6.1.5 Each anchor rope or strap and associated fittings shall have a minimum breaking load of 8 kN (1800 lbf) at the juncture of the strap and the inflatable device.

6.1.6 The anchor system shall be designed so that the anchor ropes or straps are secured in a manner that prevents the inflatable device lifting completely off the ground.

6.1.7 Anchor systems shall be consistent throughout.

6.2 Structural Integrity:

6.2.1 Air Pressure:

6.2.1.1 The minimum air pressure inside the inflatable device delivered by the blower shall in all cases be sufficient to give a firm and reliable footing and adequately support the structure. The maximum individual weight specified by the manufacturer shall be placed on each structural unit without grounding.

6.2.1.2 Horizontal surfaces shall support the load specified in Table 1, without grounding. When tested in accordance with the structural integrity test method 6.2.1.3 and 6.2.1.4, the appropriate load shall remain supported by the inflatable device at each test point.

6.2.1.3 *Structural Integrity Test Method*—For platforms with an area greater than 0.93 m² (10 ft²), the load, as defined in Table 1, shall be applied vertically, without shock, and the total load shall remain for 5 minutes. For the purpose of applying the load, the platform shall be divided into four equal area quadrants. The total load shall be located in equal portions, in the center of each quadrant and at the center point of the platform, for a total of 5 points. For platforms with an area less than 0.93 m² (10 ft²), apply the load over a 305 mm (1 ft) diameter area.

(1) Platforms with an area less than 0.93 m² (10 ft²) intended for access and egress that rest on the ground with a height of 305 mm (12 in.) or less are exempt from this requirement.

(2) Platforms with an area less than 0.93 m² (10 ft²) intended for lounging are exempt from this requirement.

(3) The exit area of a slide, for the last 460 mm (18 in.), with a height of 305 mm (12 in.) or less, is exempt from this requirement.

TABLE 1 Area and Load on Platform

Area m ² (ft ²)	Load kg (lb)
<0.92 (<10)	85 (190)
0.92-1.85 (10-20)	127 (280)
1.85-2.80 (20-30)	170 (375)
2.80-3.70 (30-40)	204 (450)
>3.70 (>40)	250 (550)

6.2.1.4 *Structural Integrity Test Procedure*—The loading procedure shall be as follows:

- (1) Ensure the inflatable device is inflated to its specified minimum air pressure or to the pressure of the supplied blower.
- (2) Select the appropriate load to be applied from Table 1.
- (3) Place the individual loads indicated in Table 1 onto each individual test position selected in accordance with Fig. 2, example of test position grid, until the loads occupy all five test positions.

6.3 *Deflation:*

6.3.1 The design of an inflatable device shall ensure that, upon loss of air pressure, the inflatable device remains supported with sufficient clearances for the oldest (tallest) user and adequate time for the youngest user to evacuate.

6.3.2 It is acceptable to use an independent support system.

6.3.3 Inflatable devices shall be designed to ensure adults are able to gain access in order to assist users during evacuation.

6.3.4 The inflatable device cannot tip over and create a hazardous situation while deflating.

6.3.5 If a tunnel is under the highest platform, the opening of the tunnel cannot decrease by half the initial height before the 30 second mark.

6.3.6 *Deflation Test Method:*

6.3.6.1 Ensure the inflatable device is inflated to its specified minimum air pressure or to the pressure of the supplied blower.

6.3.6.2 Apply the appropriate test load based on the height of the highest platform as specified in Table 2.

6.3.6.3 The size of the test load shall be a 40.0 cm (16 in.) diameter sand bag.

TABLE 2 Deflation Load and Time

Height of Highest Platform, mm (ft)	Total Load, kg (lb)	Minimum Deflation Time
<610 mm (2)	20 (44)	10 s
610–1525 mm (2–5)	20 (44)	20 s
>1525–2134 mm (5–7)	34 (75)	30 s
>2134 mm (7)	34 (75)	40 s

6.3.6.4 Place the load on the geometric center of the highest platform or playing surface.

6.3.6.5 Timing begins when the blower motor is stopped.

6.3.6.6 Timing is stopped when the test load contacts the ground.

6.4 *Head and Neck Entrapment:*

6.4.1 Inflatable devices shall be designed and constructed or assembled so that any openings that are accessible to users shall meet the following performance requirements to reduce the risk of accidental head or neck entrapment by either a head-first or feet-first entry into the opening.

6.4.2 *Accessible Openings*—A completely bounded rigid opening is accessible when a torso test probe (see Fig. 3) can be inserted into the opening to a depth of 102 mm (4.0 in.) or more.

6.4.2.1 *Test Procedure for Completely Bounded Rigid Openings:*

(1) An opening fails the test if the opening admits the torso probe, but does not admit the head probe.

(2) Place the torso probe in the opening with the plane of the base of the probe parallel to the plane of the opening; rotate the probe to its most adverse orientation (that is, major axis of the base of the probe parallel to the major axis of opening).

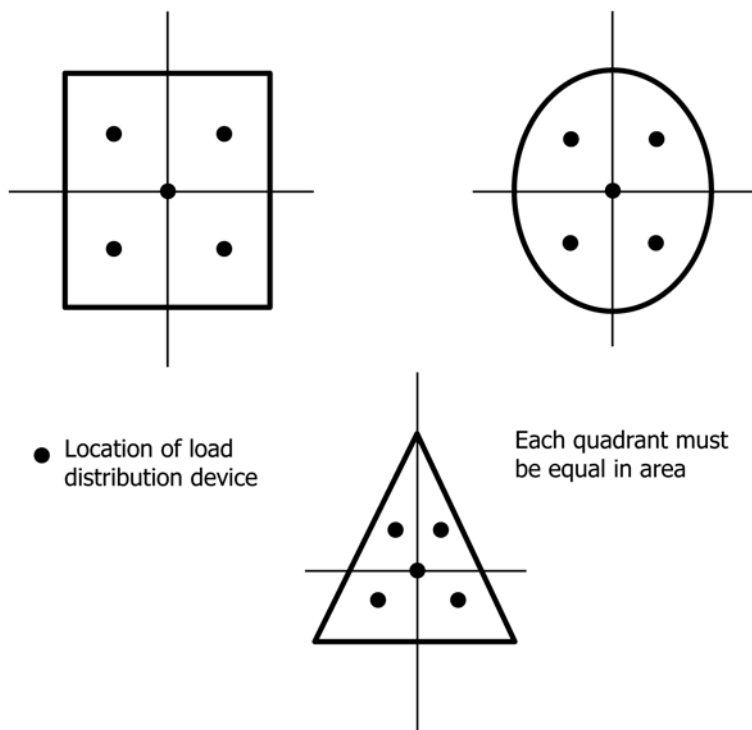
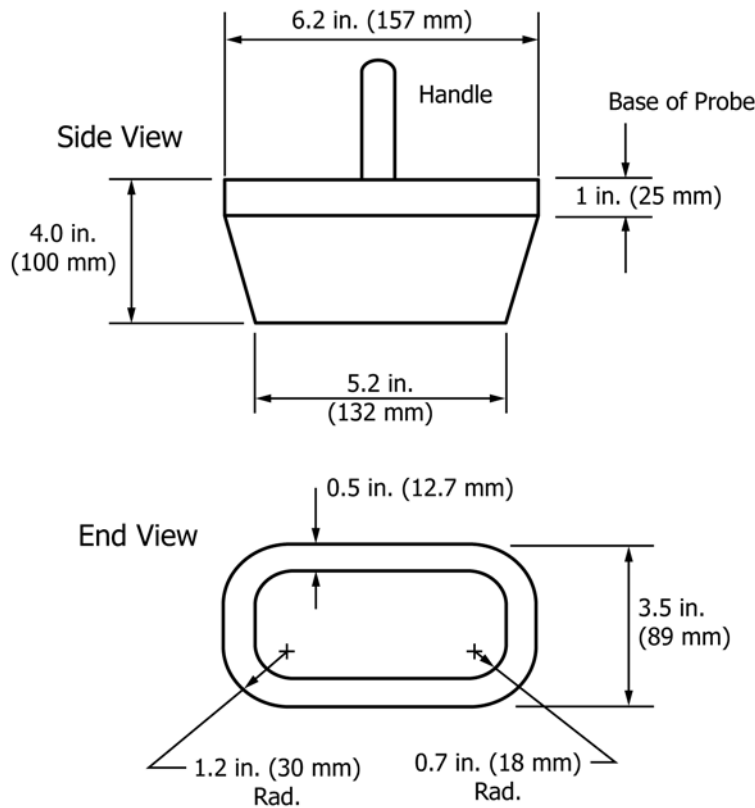

FIG. 2 Example of Test Position Grid



Torso Probe
(Material: Any rigid material)

FIG. 3 Torso Probe

6.4.2.2 If the torso probe can be inserted into the opening to a depth of 102 mm (4.0 in.) or more, place the head probe (see Fig. 4) in the opening with the plane of the base of the probe parallel to the plane of the opening.

6.4.2.3 An opening passes this test if (1) the opening does not admit the torso probe when it is rotated to any orientation about its own axis, or (2) the opening admits the torso probe and also admits the head probe.

6.4.3 *Non-Rigid Completely Bounded Openings*—A non-rigid opening such as, but not limited to flexible nets, water tubing, tarps, and plastic enclosures is considered accessible if a torso probe will penetrate the opening to a depth of 102 mm (4.0 in.) or more when tested in accordance with the test procedure outlined in 6.4.3.2.

6.4.3.1 If the non-rigid opening consists of a material that can be manipulated to create a larger opening under a force of no greater than 22.2 N (5 lb) in any orientation or plane, conduct the test with the opening in its worst-case orientation under the applied force.

6.4.3.2 *Test Procedure for Completely Bounded Non-Rigid Openings:*

(1) Place the torso probe in the opening, tapered-end first, with the plane of its base parallel to the plane of the opening; rotate the probe to its most adverse orientation (that is, the major axis of the base of the probe parallel to the major axis of the opening); apply a force of 222 N (50 lb) to the probe to attempt to pass it through the opening.

(2) If the base of the probe passes through the opening, place the large head probe in the opening, tapered end first, with the plane of its base parallel to the plane of the opening. Attempt to pass it through the opening freely.

(3) A non-rigid opening passes the test if: (a) the opening does not allow the torso probe to be inserted so deep that the opening admits the base of the probe when it is rotated to any orientation about its own axis, or (b) the opening allows full passage of the torso probe and also allows the large head probe to pass completely through.

(4) A non-rigid opening fails the test if the opening allows full passage of the torso probe but does not admit the large head probe.

6.5 *Angles:*

6.5.1 The angle of any vertex formed by adjacent components shall be greater than 55° (0.96 rad), unless the lower leg is horizontal or projects downwards, refer to Fig. 5, recommended angle measurements.

6.5.2 An exception to this recommendation can be made if an in-filled shield is attached to the vertex between adjacent components and the shield is of sufficient size to prevent a 229 mm (9 in.) diameter circular template from simultaneously touching components on either side of the vertex, see Fig. 6, in-fill shield for angles.

6.6 *Entrapment of Body:*

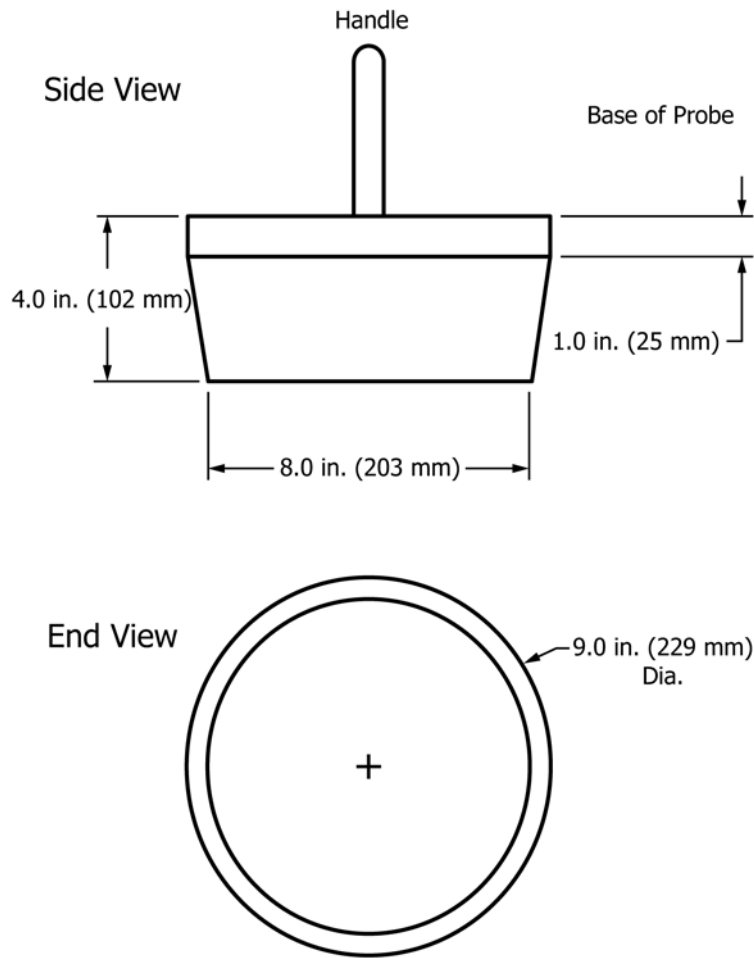

Material: Any Rigid Material

FIG. 4 Head Probe

6.6.1 Adjacent inflated surfaces shall be more than 120 mm (4.75 in.) apart if the aperture formed is more than 200 mm (7.9 in.) deep. See Fig. 7 for body entrapment examples.

6.6.2 Inflatable device tunnels shall comply with the following requirements:

6.6.2.1 Tunnels of 750 mm (29.5 in.) or less in length shall: (1) Have an initial opening diameter of at least 400 mm (15.75 in.);

(2) Comply with head and neck entrapment requirements for non-rigid completely bounded openings; and

(3) Be capable of expansion to at least 400 mm (15.75 in.) diameter for the entire length of the inner panel under a force of no more than 222 N (50 lb).

6.6.2.2 Tunnels over 750 mm (29.5 in.) and up to 2 m (6.6 ft) in length shall be of at least 500 mm (19.7 in.) internal diameter.

6.6.2.3 Tunnels of over 2 m (6.6 ft) in length shall be at least 750 mm (29.5 in.) internal diameter and have access gaps or open branches at least every 2 m (6.6 ft).

6.7 Protrusions:

6.7.1 When tested, no protrusion shall extend beyond the face of the appropriate test gauge as shown in Figs. 8 and 9.

6.7.2 Protrusions that are non-rigid and moveable are exempt from the requirements of 6.7.

6.7.3 Perform protrusion tests by successively placing each test gauge shown in Fig. 8 to determine if the protrusion extends beyond the face of the smallest gauge that can be successfully placed over the protrusion (for example of test gauge use, see Fig. 10).

6.7.4 Upright Protrusions—Protrusions that fit within any of the gauges and that project upwards from a horizontal plane shall have no projection extending more than 3 mm (0.125 in.) perpendicular to the plane of the initial surface (see Fig. 11).

6.7.5 Forced Motion—Protrusions shall not extend beyond the face of the test gauge shown in Fig. 9. Place the gauge shown in Fig. 9 over any protrusions such that the axis of the hole is parallel to both the intended path of the travel and a horizontal plane.

6.7.6 Slides—Slides, including protective barriers and their method of attachment and transition areas, pose a greater risk of entanglement than other areas, therefore, the following requirements apply to slides and sliding devices:

6.7.6.1 Any accessible protrusion that allows the 76 mm (3.0 in.) protrusion gauge to pass over it shall have no

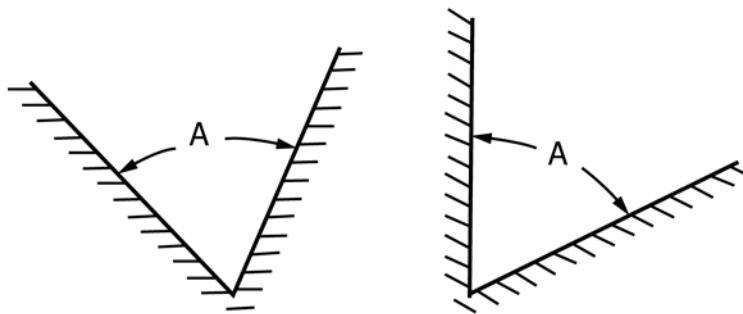

Angle "A" shall exceed 55 degrees

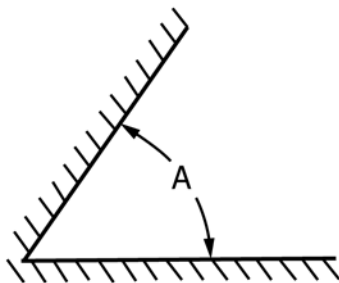

Angle A is exempt if one leg of the "V" is horizontal or slopes downward from the apex

Recommendations for Angles

FIG. 5 Recommended Angle Measurements

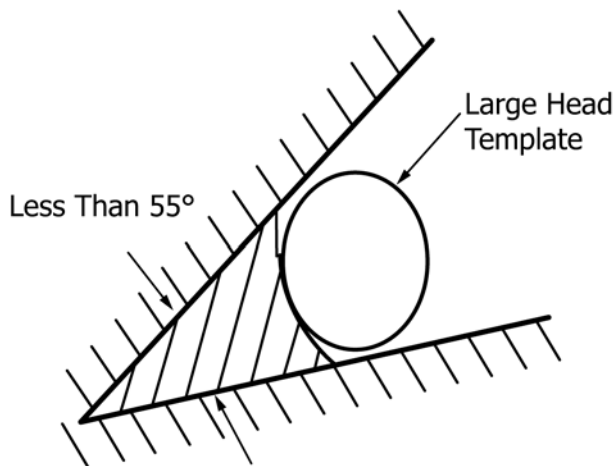

FIG. 6 In-Fill Shield for Angles Less than 55°

projection extending perpendicular from the initial surface more than 3 mm (0.125 in.). The area that is subject to this requirement is outlined in Fig. 12. The outside surfaces of tunnel slides that are completely enclosed are not subject to the requirements of this section.

6.7.6.2 Slides shall be constructed in such a manner as to provide a smooth continuous sliding surface with no gaps or spaces that might create an entanglement hazard such as, but

not limited to, the space created between sidewalls when two single slides are combined to create a double wide slide or the point where a hood attaches to the sidewalls of a slide.

6.7.6.3 No protrusion shall terminate in a dimension greater than that of the base dimension (see Fig. 13). In the case of hardware, the base dimension shall be defined as the major dimension of the attachment nut or bolt head.

6.7.6.4 Exclusions—Protrusions are exempt from the requirements of 6.7 and shall be considered inaccessible if the protrusion cannot be placed within the 76.2 mm (3.0 in.) diameter test gauge.

6.8 Blowers:

6.8.1 Blowers and electrical cords shall be positioned at least 1.3 m (4.3 ft) from a walled side of the inflatable device and 2.5 m (8.2 ft) from an open side. Electrical cords shall not pass under the inflatable device and shall not interfere with its operation.

6.8.2 Blower tubes shall be designed to enable the positioning of the blower away from users.

6.8.3 Blowers shall not be positioned in any of the fall zones.

6.8.4 Blowers should be positioned externally.

6.8.5 If a blower has to be positioned internally, it shall be positioned so that users cannot contact it during use of the inflatable device or during unintended deflation.

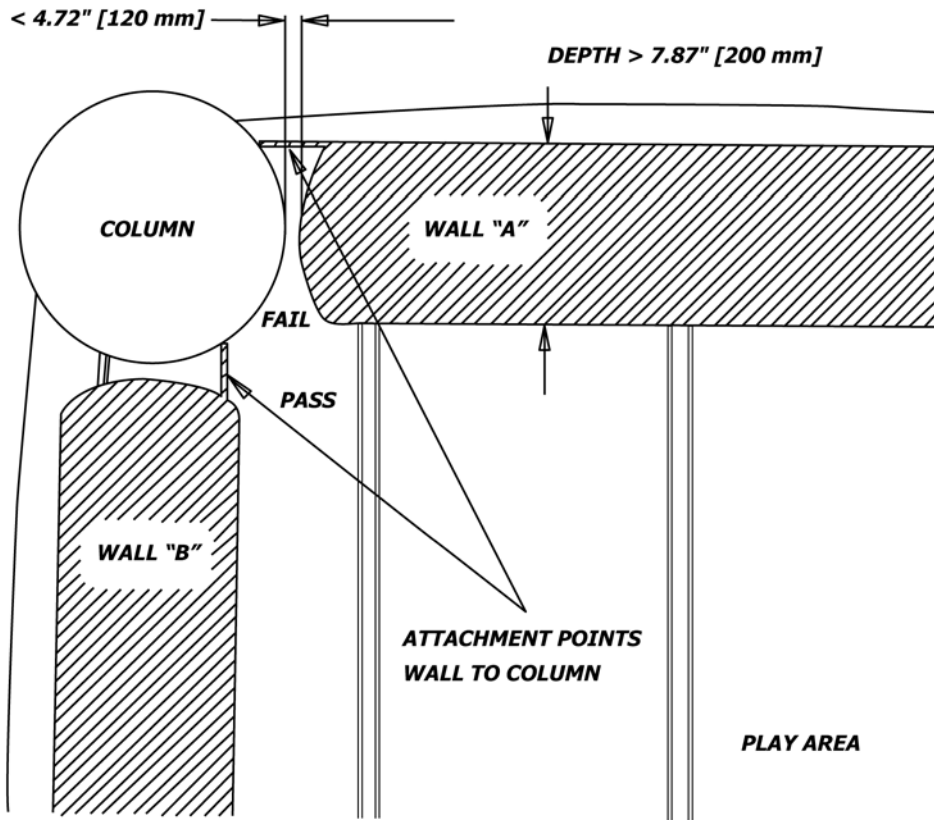
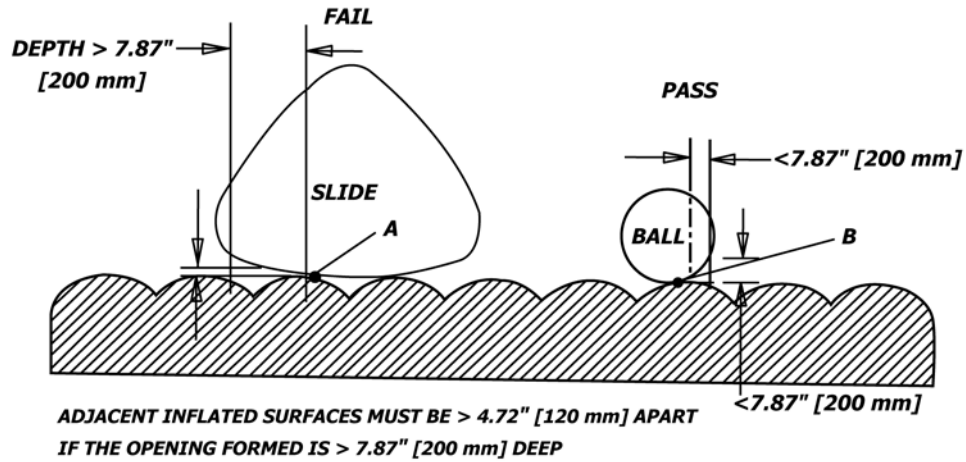

- **ENTRAPMENT IS PRESENT BETWEEN WALL "A" AND COLUMN**
- **NO ENTRAPMENT IS PRESENT BETWEEN WALL "B" AND COLUMN**

FIG. 7 Body Entrapment Points

6.8.6 The blower unit or any other electrical equipment associated with the inflatable device shall meet an appropriate electrical standard for outdoor use products; contain a listed

Ground-Fault Circuit-Interrupter (GFCI), protected power cord, and a warning not to use extension cords.

6.8.7 Gasoline driven blowers shall not be used.

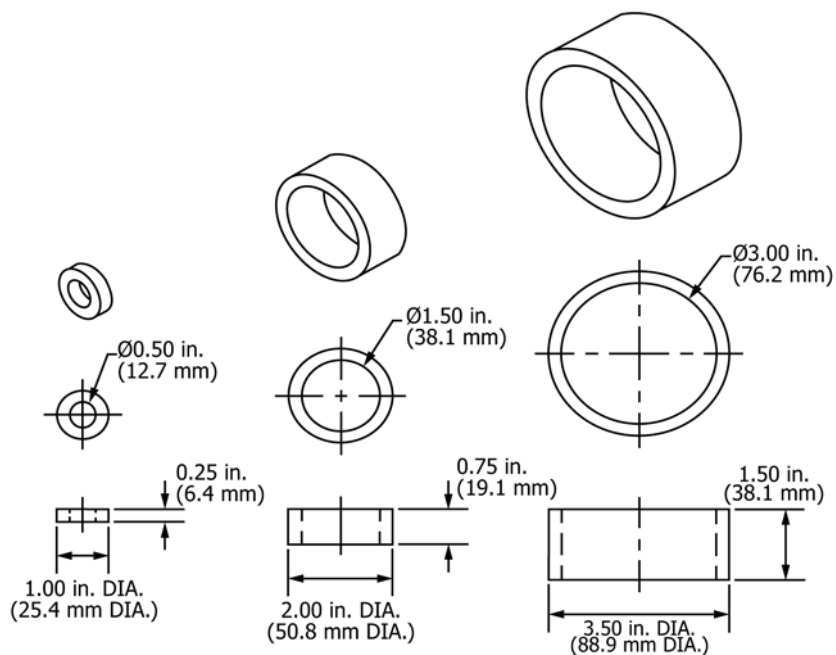

FIG. 8 Protrusion Gauges

Keep the face of the gauge vertical and its axis parallel to the plane of intended travel during the test.

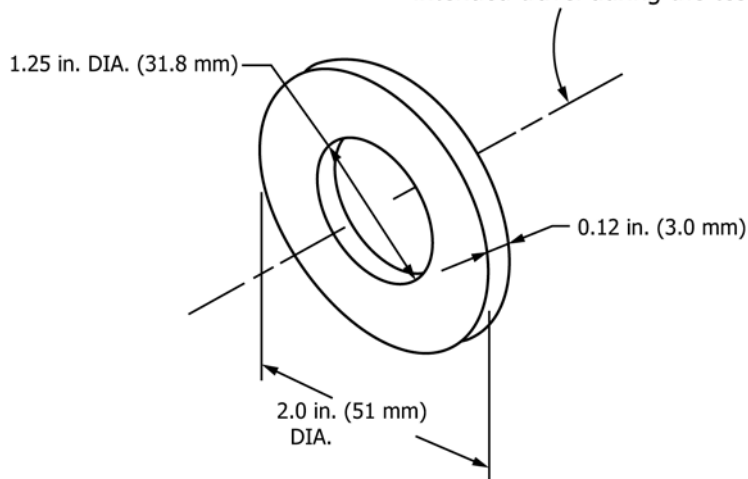

FIG. 9 Additional Protrusion Gauge

6.8.8 Blowers shall meet the applicable requirements of UL 507 and 16 CFR 1505 with the exception of cord length and amperage requirement.

6.8.9 The electrical cord shall be protected and shall be at least a minimum of 7.6 m (25 ft) in length.

6.8.10 The GFCI shall be an integral part of the grounded appliance cord located within 305 mm (12 in.) of the attachment-plug face.

6.8.11 Shielding shall be provided to ensure the air volume to the intake of the blower cannot be affected by foreign debris.

6.8.12 Moving components of the blower should be inaccessible to the finger probe as specified in 16 CFR, Sections 1500.48 and 1500.49 (see Fig. 14).

7. Open Sides, Access and Egress

7.1 On any open side, the free height of fall shall be no greater than 760 mm (30.0 in.) in the unloaded condition. On any open side, the manufacturer shall specify the type of impact absorbing material to be placed on the ground at that

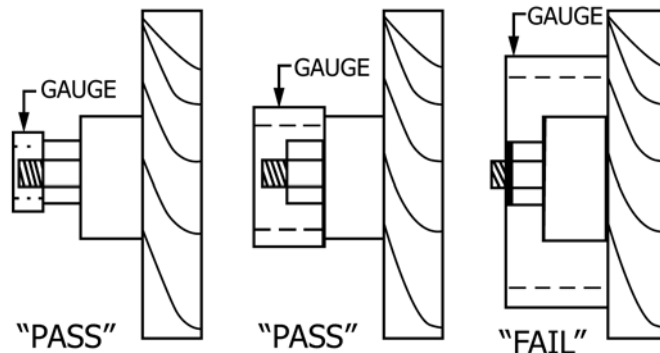

FIG. 10 Compound Projection Test

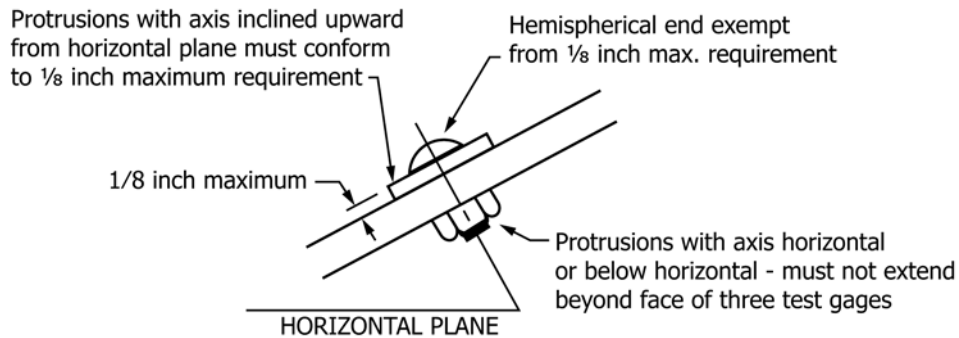

FIG. 11 Upright Protrusion Test

side. The impact absorbing material shall be at least 1.8 m (6 ft) from the opening in all directions away from the inflatable device.

7.2 Information on inflatable device surfacing materials:

7.2.1 The instructions shall include the manufacturer's determination of maximum fall height for the inflatable device.

7.2.2 Maximum fall height for the inflatable device is determined as follows:

Elevated platforms with protective barriers = the height of the platform,

Climbers = top surface of the component

7.2.3 A step or ramp shall be wider than the access/egress opening.

7.2.4 A step or ramp shall have a tread depth of at least 1.5 times the height of the playing area to which it is attached. See Fig. 15.

7.3 Hand Support and Steps:

7.3.1 All rungs and padding used on the inflatable device shall not spin, rotate or roll while in use.

7.3.2 Padded rungs that are used for handgrip shall be at a minimum 24.1 mm (0.95 in.) when compressed in any direction over the full length of the rung with 44.5 N (10 lb) of force but shall be no larger than 39.4 mm (1.55 in.) in diameter when not compressed.

7.3.3 Hard rungs that are used for handgrip shall be between 24.1 mm (0.95 in.) and 39.4 mm (1.55 in.) in diameter.

7.3.4 The center-to-center distance, measured diagonally, between rungs with fixed handholds shall be no greater than 914 ± 50.8 mm (36 ± 2.0 in.). The center of the first hand gripping rung shall be between 559 ± 50.8 mm (22.0 ± 2.0 in.)

and 965 ± 50.8 mm (38.0 ± 2.0 in.) above the level of the platform. (See Fig. 16.)

7.3.5 Rungs shall be evenly spaced within a tolerance of 50.8 mm (2.0 in.) measured vertically.

7.3.6 Rung ladders, stepladders, stairways, and ramps shall meet the requirements below:

7.3.6.1 The tread width shall be ≥ 406 ± 50.8 mm (≥ 16 ± 2.0 in.). Tread width shall be measured from parallel lines drawn from the outermost portion of the designated climbing treads. For climbing surface with two-abreast access, each designated climbing surface shall be evaluated for width requirements. For pocket steps, tread width is measured from the outermost point of the outermost steps.

7.3.6.2 The slope shall be greater than 50° (0.87 rad) and less than 90° (1.57 rad) from horizontal.

7.3.6.3 Vertical rise shall be < 305 + 50.8 mm (< 12 + 2.0 in.). Vertical rise shall be measured from the bottom surface of each step to the bottom surface of the next step. If the next step is diagonal to the first, the measurement shall be taken from a line drawn parallel to the bottom of the next step. The first step shall be measured from the top surface of the take-off platform.

7.3.6.4 Pocket step tread depth shall be designed to have a minimum depth of 50.8 + 24.5 mm (2.0 + 1.0 in.) when measured at rest and have a maximum depth of 139.7 + 25.4 mm (5.5 + 1.0 in.) when measured with a 66.7 N (15 lb) force applied in all directions through a 25.4 mm (1.0 in.) diameter rod with a full radius at the tip.

7.3.6.5 Bump steps shall be designed to have a minimum depth of 94.0 + 24.5 mm (3.7 + 1.0 in.) and a maximum depth of 165.1 + 24.5 mm (6.5 + 1.0 in.) when measured at rest.

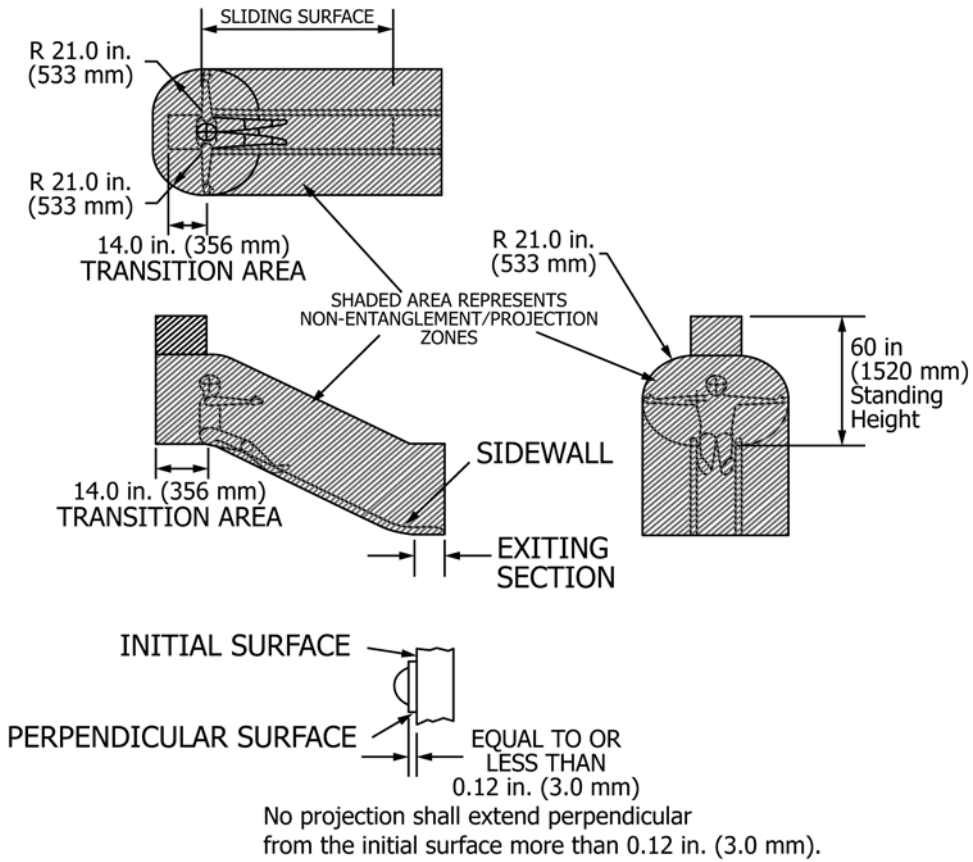

FIG. 12 Areas Subjected to 6.7.6.1

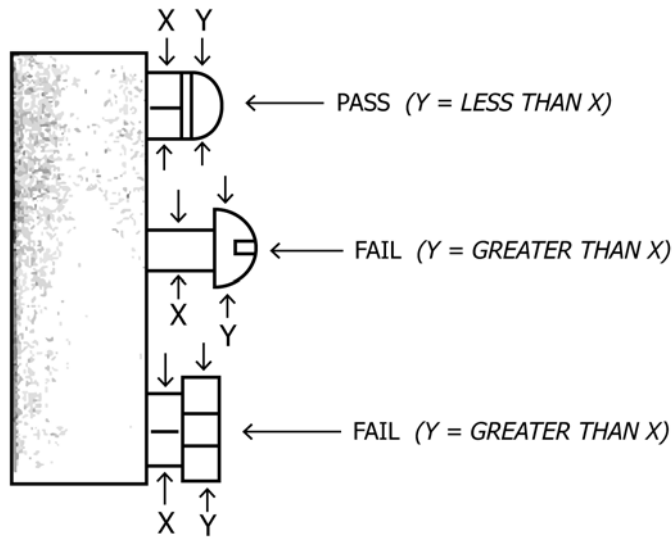

FIG. 13 Examples of Protrusion Configuration

7.3.6.6 All steps shall be evenly spaced within a tolerance of 50.8 mm (2.0 in.) measured vertically.

7.3.6.7 Shall not trap water and shall not allow the accumulation of debris or, if they contain pocket steps, instructions for cleaning the pockets and removing debris after each play cycle shall be supplied.

8. Containment

8.1 Means to contain users shall be provided where the level platform height is greater than 700 mm (27.5 in.).

8.2 On inflatable devices with a level platform height of greater than 700 mm (27.5 in.) up to and including 3 m (10 ft),

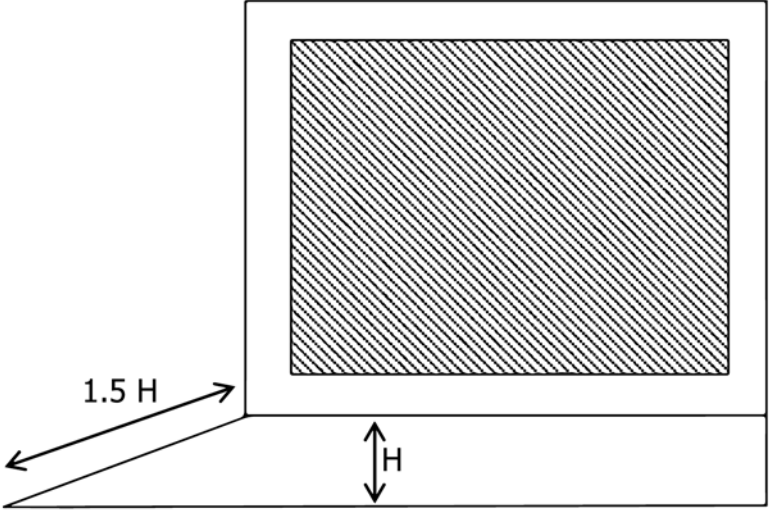
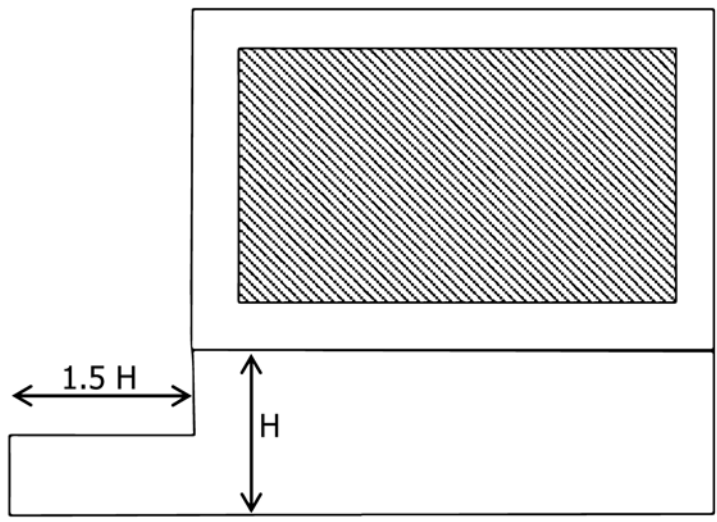

FIG. 15 Tread Depth of Step and Ramp

9.4.2.1 For slides over 0.91 m (3 ft) in height that are intended to be used when wet, the length of the run-out section shall be twice the distance as specified above.

9.4.2.2 Pooled water shall not be considered part of the run-out section.

9.5 Slide Exit Clearance Zone:

9.5.1 A clear zone shall extend from the end of the slide.

9.5.2 Slide exit clearance zones for two or more slides are allowed to overlap, if their sliding paths are parallel.

9.5.3 Merging slides with converging paths of travel shall not overlap at the exits.

10. Marking and Labeling

10.1 General Inflation Device Information:

10.1.1 General inflatable device information shall be provided by the manufacturer and shall:

10.1.1.1 Be printed legibly in English and in simple form; and

10.1.1.2 Use illustrations wherever possible.

10.2 Each inflatable device shall be permanently marked in a conspicuous location with the name and one of the following: address (city, state, and zip code), toll free telephone number or Internet web address of the manufacturer, distributor, or seller.

10.3 The following information shall be permanently and prominently displayed on the inflatable device:

10.3.1 Age range of the product and a minimum of one of the following:

10.3.1.1 Total weight limit of the product; or

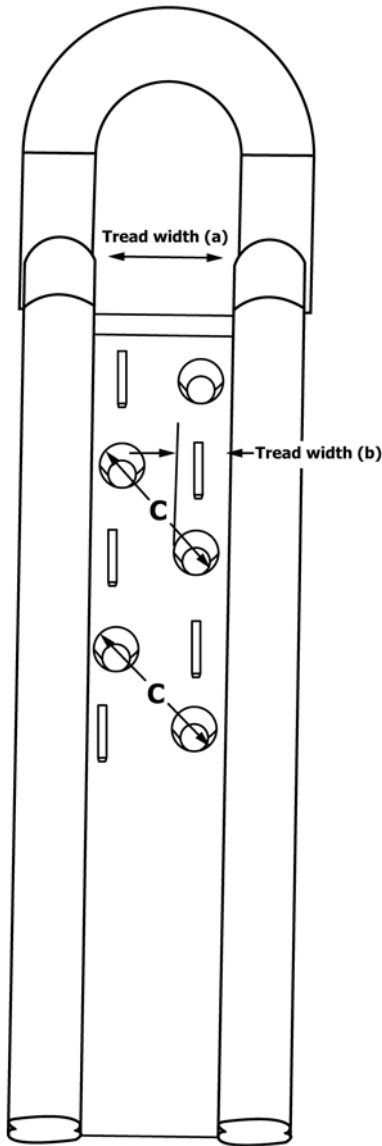

FIG. 16 Rung Distance Measurements

TABLE 3

Lowest Intended Age (years)	2	3	4	5	6
Height mm (in.)	711 (28)	737 (29)	838 (33)	864 (34)	914 (36)

10.3.1.2 Total number of users.

10.4 The following information shall be included on the inflatable device that is permanently marked in a conspicuous location that, as a minimum, details operation, in particular the following:

10.4.1 Any restrictions relating to operating surfaces and anchors.

10.4.2 No shoes or glasses are to be worn on the inflatable device.

10.4.3 Any restrictions related to operating in windy conditions.

10.4.4 Adult supervision recommended.

10.4.5 Any restrictions relating to the blower and electricity, including not using an extension cord.

10.4.6 The following or equivalent warning, on the motor or on the electrical cord itself in ANSI Z535.4 consistent format, which states:

“WARNING- Electrocutation Hazard
Do not use extension cord with this product.”

10.5 Word message on the warning label—WARNING: Failure to follow the installation and operating instructions present a risk of serious injury or death.

10.6 *Water Safety Labels:*

10.6.1 When more than one safety label is required per 10.6.3, they may be grouped in one or more frame(s).

10.6.2 All on-product Inflatable device safety labels required by 10.6.3 shall be permanent, conspicuous, ANSI Z535.4 consistent, and shall be legible from a distance of at least 1 m (3 ft).

10.6.3 Each Inflatable device shall bear a safety label addressing drowning that consists of a safety alert symbol in the signal word panel, includes a pictorial panel, and a message panel. The pictorial shall represent direct supervision of young children. The text of the message panel shall state these or equivalent words:

Children—especially toddlers—are at high risk of drowning.

Closely watch children who are in or near this Constant Air Inflatable.

Empty water from Constant Air Inflatable after use.

10.6.3.1 An example of such a warning can be found in Annex A1. Alternative ANSI consistent warning designs are acceptable as long as they are conspicuous, legible and include a safety alert symbol in the signal word panel, pictorial panel, and message panel that clearly state the hazard and how to avoid it including the need for close supervision.

10.6.3.2 All Inflatable device with a water depth above 305 mm (12 in.) shall bear a safety label warning addressed against diving into shallow water. This warning safety label shall consist of a signal word panel; include a pictorial panel, and a message panel. The pictorial shall represent a dive into shallow water with the prohibition sign. The message panel shall state these or equivalent words:

No Diving.

You can break your neck and be paralyzed!

10.6.3.3 An example of such a warning can be found in Annex A1. Alternative ANSI consistent warning designs are acceptable as long as they are conspicuous, legible and include a safety alert symbol in the signal word panel, pictorial panel, and message panel that clearly state the hazard and how to avoid it.

10.7 Packaging, literature accompanying the inflatable device and point-of-sale presentations shall not use words, statements, or graphics that are inconsistent in any way with the safety labeling instructions for use or assembly.

10.8 *Identification of Conformance to This Standard*—No inflatable device shall indicate, by label or other means, conformance with this specification unless it conforms to all requirements contained herein. The following statement is suggested for use in identifying a inflatable device that

conforms to all requirements in this specification:
 “This inflatable device conforms to ASTM F2729, Standard Consumer Safety Specification for Constant Air Inflatable Play Devices for Home Use.”

11. Instructional Literature

11.1 Instructions shall be provided with the inflatable device and shall be easy to read and understand. These instructions shall include information on assembly, maintenance, cleaning, storage and use.

11.2 The first warning of the instructions shall address: Read all instructions before assembling this inflatable device and keep instructions for future use.

11.3 Instructions shall also contain all other warnings addressed in Section 10.

11.4 The manufacturer shall convey the following installation information:

11.4.1 A parts list shall be provided.

11.4.2 The method used for the anchoring system and the number of anchor points. The manufacturer shall provide information to the consumer on appropriate anchor method for different soil types and that the stakes are installed below ground level.

11.4.3 The maximum safe wind speed while inflated.

11.4.4 Operational space requirement.

11.4.5 The maximum allowable slope of the site.

11.4.6 The product shall be inflated with blower provided or with other manufacturer specified replacement blower.

11.4.7 That a GFCI device needs to be used, not to use an extension cord and to keep the blower and power cord away from water.

11.4.8 Product shall be fully inflated and anchored before use.

11.5 Place the inflatable device on level ground, not less than 1.8 m (6 ft) in any direction from any structure or obstruction such as a fence, garage, house, overhanging branches, laundry lines, or electrical wires.

11.6 Do not install inflatable devices over concrete, asphalt, packed earth, carpet or any other hard surface. A fall onto a hard surface can result in serious injury to the user.

11.7 Areas immediately adjacent to all areas of access/ egress of the inflatable device shall have use zones, which are free of obstacles and covered with impact attenuating surfacing for a minimum distance of at least 1.8 m (6 ft) and shall include the manufacturers’ critical fall height.

11.8 *Maintenance/Hygiene:*

11.8.1 The designer or manufacturer of each inflatable device shall provide maintenance and hygiene instructions.

11.8.1.1 The manufacturer’s maintenance instructions shall include recommendations for non-flammable, non-toxic cleaning and sanitizing solutions known to be compatible with materials used in the construction of the inflatable device.

11.9 *Manufacturer’s Maintenance Instructions:*

11.9.1 Manufacturer’s maintenance instructions shall include but not be limited to the following:

11.9.1.1 Description of recommended assembly and disassembly techniques and procedures as deemed necessary by the manufacturer to accomplish repairs and maintenance.

11.9.1.2 Parts and components shall be described and numbered for ordering purposes.

11.9.1.3 Recommended lubrication procedures and frequencies for the inflatable device, if applicable.

11.9.1.4 Manufacturer’s recommendation on identification of wear and deterioration patterns.

11.10 *Operating Information:*

11.10.1 The manufacturer shall provide all necessary operating information and requirements, including but not limited to the following:

11.10.1.1 *Supervision*—Where to be located to ensure observation of all parts of the play area, all activity on the inflatable device and keeping the entrance free from obstruction at all times.

11.10.1.2 *Users Limits*—Restriction of the maximum number of users at one time and restriction of the maximum weight to the inflatable device.

11.10.1.3 *Environmental Conditions*—Affecting the set up of the inflatable device and users on the inflatable device.

11.10.1.4 *Users Dress Code*—Avoid and remove all head gear, loose clothing, hard, sharp, or dangerous objects, such as, but not limited to: jewelry, ponchos, scarves, helmets, etc.

11.10.1.5 *Proper Use of Product:*

(1) Separation of larger children from smaller children.

(2) Prevention of users from climbing or hanging on the containing walls.

(3) Prevention of inappropriate activities (for example, somersaults and rough play).

(4) Restrictions on the consumption of food, drink and gum, and the

(5) Correct use position of inflatable device (for example, on slide, climbing wall).

(6) Keep pets off of the inflatable device.

(7) Do not attach items to the inflatable device that are not specifically designed for use with the inflatable device, such as, but not limited to, jump ropes, clothesline, pet leashes, cables and chain as they have the potential to cause a strangulation hazard.

11.11 Inflatable device that utilize containment walls that are intended to pool or hold water:

11.11.1 The instructions for inflatable device with a depth of water greater than 460 mm (18 in.) shall direct consumers to the barrier recommendations as described in CPSC Pub. No. 362 Safety Barrier Guidelines for pools found at www.pool-safety.gov.

11.11.2 Safety information included in the printed instructions for inflatable device that utilize containment walls that are intended to pool or hold water:

11.11.2.1 Safety information and warnings relating to drowning shall be presented at the beginning of page one of the instruction booklet. The first item mentioned under Inflatable device safety shall be a drowning warning in the format of an ANSI Z535.4 consistent safety label. The label shall consist of a signal word panel, include a pictorial panel, and a message panel that clearly states the hazard and how to avoid it. The

warning shall be offset from other text through the use of borders. For instruction manuals that are printed exclusively in black and white or are monochromatic, the warning label may be printed in black and white. The pictorial shall represent direct supervision of young children. An example of such a pictorial can be found in **Annex A1**. The text of the message panel shall state these or equivalent words:

Children—especially toddlers—are at high risk of drowning.

Closely watch children who are in or near this Constant Air Inflatable.

Empty water from Constant Air Inflatable after use.

11.11.2.2 In addition to the drowning warning label, the instruction manual shall list the following drowning-related safety information (or equivalent), if applicable:

(1) Prevent Young Children from Drowning:

(a) Install fencing or other approved barrier around all sides of the Constant Air Inflatable.

(b) State or local laws or codes may require fencing or other approved barriers. Check state or local laws and codes before setting up the Constant Air Inflatable.

(c) Drowning occurs silently and quickly. Assign an adult to supervise the Constant Air Inflatable.

(d) Keep children in your direct sight when they are in or near the Constant Air Inflatable and when you are filling and emptying the Constant Air Inflatable.

(e) When searching for a missing child, check the pool first, even if you think your child is in the house.

(2) Be Prepared to Respond to an Emergency:

(a) Keep a working phone and list of emergency numbers near the Constant Air Inflatable.

(b) Become certified in cardiopulmonary resuscitation (CPR) so you can respond to an emergency.

11.11.3 Safety information included in printed instructions for inflatable device with a water depth above 305 mm (12 in.):

11.11.3.1 Instructions for inflatable device with a water depth above 305 mm (12 in.) shall bear an ANSI Z535.4 consistent safety label warning against diving into shallow water. This warning shall consist of a safety alert symbol in the signal word panel, a pictorial panel, and a message panel. The warning shall be offset from other text through the use of a border and may be rendered in the Pantone equivalent safety color. For instruction manuals that are printed exclusively in black and white or are monochromatic, the warning may be printed in black and white. The pictorial shall represent a dive into shallow water with the prohibition sign. An example of such a warning can be found in **Annex A1**. The message panel shall state these or equivalent words:

No Diving.

You can break your neck and be paralyzed!

11.11.4 Safety information included in printed instructions for inflatable device with electrical components:

11.11.4.1 An ANSI Z535.4 consistent warning about electrocution risks shall be placed at the beginning of the instructions pertaining to the Inflatable device setup. This warning shall consist of a safety alert symbol in the signal word panel, a pictorial panel, and a message panel. The warning shall be offset from other text through the use of a border and may be rendered in the Pantone equivalent safety color. For instruction manuals that are printed exclusively in black and white or are monochromatic, the warning may be printed in black and white. The text of the message panel shall state these or equivalent words:

(1) Electrocution Risk:

(a) Keep all electrical lines, radios, speakers and other electrical devices away from the Constant Air Inflatable.

(b) Do not place the Constant Air Inflatable near or under overhead electrical lines.

ANNEX

(Mandatory Information)

A1. WARNING LABELS



FIG. A1.1 Drowning Label for Type A Pools

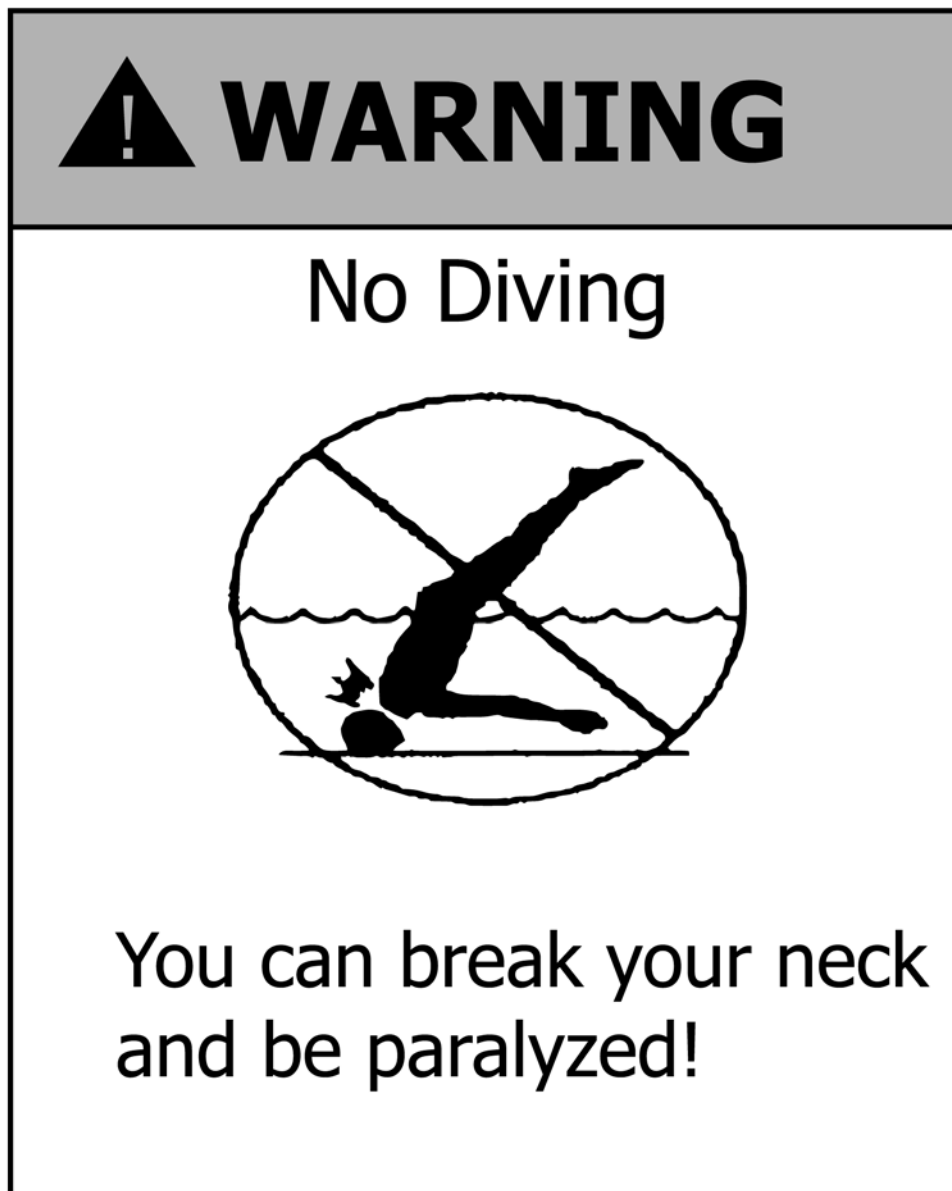

FIG. A1.2 No Diving Label

ASTM International takes no position respecting the validity of any patent rights asserted in connection with any item mentioned in this standard. Users of this standard are expressly advised that determination of the validity of any such patent rights, and the risk of infringement of such rights, are entirely their own responsibility.

This standard is subject to revision at any time by the responsible technical committee and must be reviewed every five years and if not revised, either reapproved or withdrawn. Your comments are invited either for revision of this standard or for additional standards and should be addressed to ASTM International Headquarters. Your comments will receive careful consideration at a meeting of the responsible technical committee, which you may attend. If you feel that your comments have not received a fair hearing you should make your views known to the ASTM Committee on Standards, at the address shown below.

This standard is copyrighted by ASTM International, 100 Barr Harbor Drive, PO Box C700, West Conshohocken, PA 19428-2959, United States. Individual reprints (single or multiple copies) of this standard may be obtained by contacting ASTM at the above address or at 610-832-9585 (phone), 610-832-9555 (fax), or service@astm.org (e-mail); or through the ASTM website (www.astm.org). Permission rights to photocopy the standard may also be secured from the Copyright Clearance Center, 222 Rosewood Drive, Danvers, MA 01923, Tel: (978) 646-2600; http://www.copyright.com/