



# Standard Safety Specification for Special Tip-Resistant Movable Soccer Goals<sup>1</sup>

This standard is issued under the fixed designation F2673; the number immediately following the designation indicates the year of original adoption or, in the case of revision, the year of last revision. A number in parentheses indicates the year of last reapproval. A superscript epsilon ( $\epsilon$ ) indicates an editorial change since the last revision or reapproval.

## 1. Scope

1.1 This specification covers safety requirements aimed at providing for safer use of soccer goals and reducing injuries and fatalities.

1.2 This specification addresses the risk of accidental tip over or pull over of soccer goals.

1.3 This specification applies only to movable goals whose inside measurements are 6½ to 8 ft (2 to 2.4 m) high and 18 to 24 ft (5.5 to 7.3 m) wide.

1.4 This specification applies only to movable goals meeting all criteria in Guide F1938 and Safety and Performance Specification F2056 and, in addition, meets criteria for tip resistance before installation.

1.5 This specification covers special tip-resistant goals that are intended to complement standard goals meeting Guide F1938 and Safety and Performance Specification F2056. These goals are designed to provide some additional degree of safety if, by accident, they are not tied down or tied down incorrectly.

1.6 This specification simulates two boys up to twelve years of age swinging together from the X-bar.

NOTE 1—Injury data supplied to the committee indicates that approximately 75 % (74 %) of the fatalities (1979-2003) were three to twelve years of age.

1.7 The values stated in inch-pound units are to be regarded as standard. The values given in parentheses are mathematical conversions to SI units that are provided for information only and are not considered standard.

1.8 *This standard does not purport to address all of the safety concerns, if any, associated with its use. It is the responsibility of the user of this standard to establish appropriate safety and health practices and determine the applicability of regulatory limitations prior to use.*

<sup>1</sup> This specification is under the jurisdiction of ASTM Committee F15 on Consumer Products and is the direct responsibility of Subcommittee F15.43 on Soccer Goal Safety.

Current edition approved Feb. 1, 2008. Published February 2008. DOI: 10.1520/F2673-08.

## 2. Referenced Documents

2.1 *ASTM Standards*:<sup>2</sup>

F1938 Guide for Safer Use of Movable Soccer Goals

F2056 Safety and Performance Specification for Soccer Goals

## 3. Terminology

3.1 *Definitions*—See Guide F1938 and Safety and Performance Specification F2056 for definitions.

## 4. Safety Requirements

4.1 Soccer goals shall be subjected to the test outline in Section 5 and shall neither tilt over nor refuse to return to its original vertical position.

4.2 Tests shall be applied to soccer goals in their original unrestrained (no tie-down) condition.

4.3 Tests shall be repeated three times.

4.4 Tests shall be applied only to movable goals.

4.5 Soccer goals shall then meet all testing criteria, instructions, and labeling listed in Safety and Performance Specification F2056 including anchoring.

## 5. Stability Test

5.1 Goals shall be set upon a flat, outdoor (earth) surface.

5.2 Two weights shall be placed 1.5 ft (0.46 m) on each side of the center of the X-bar of the goal (Fig. 1).

5.3 The weights shall be composed of bags of sand weighing  $110 \pm 2$  lb ( $50 \pm 1$  kg) each.

NOTE 2—The weights (5.3) are selected to simulate two twelve-year-old boys. (Physical characteristics of children as related to death and injury for consumer product safety design and use, 95th percentile, twelve-year-old male, 109 lb (49 kg).)

5.4 The weighed bags shall be tied firmly to the X-bar with ½-in. (1.3-cm) ropes.

5.5 Weights shall dangle from the rope and each bag spaced (vertically downward) so that the center of the bag is  $12 \pm 1$  in. ( $30.5 \pm 2.5$  cm) from the X-bar.

<sup>2</sup> For referenced ASTM standards, visit the ASTM website, www.astm.org, or contact ASTM Customer Service at service@astm.org. For *Annual Book of ASTM Standards* volume information, refer to the standard's Document Summary page on the ASTM website.

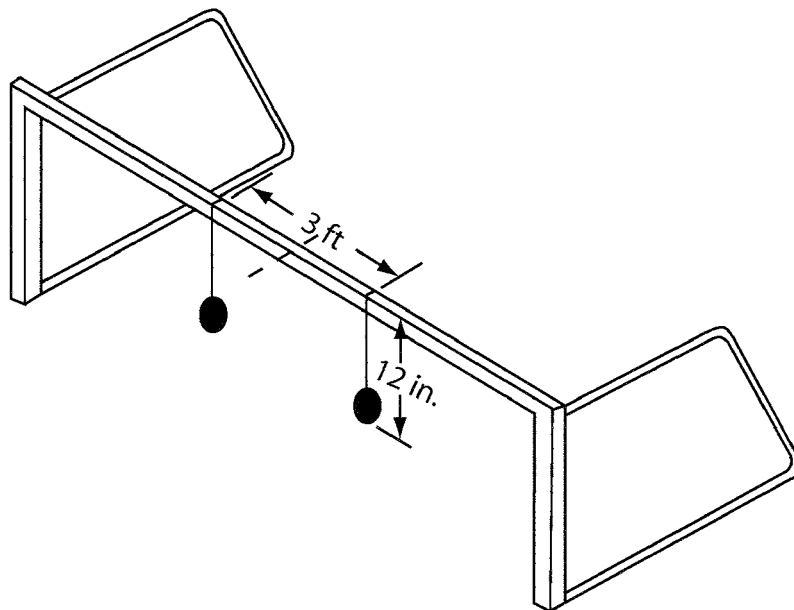

FIG. 1 Two Weights Applied at the Center of the X-Bar of the Goal and Spaced 3 ft (0.9 m) Apart

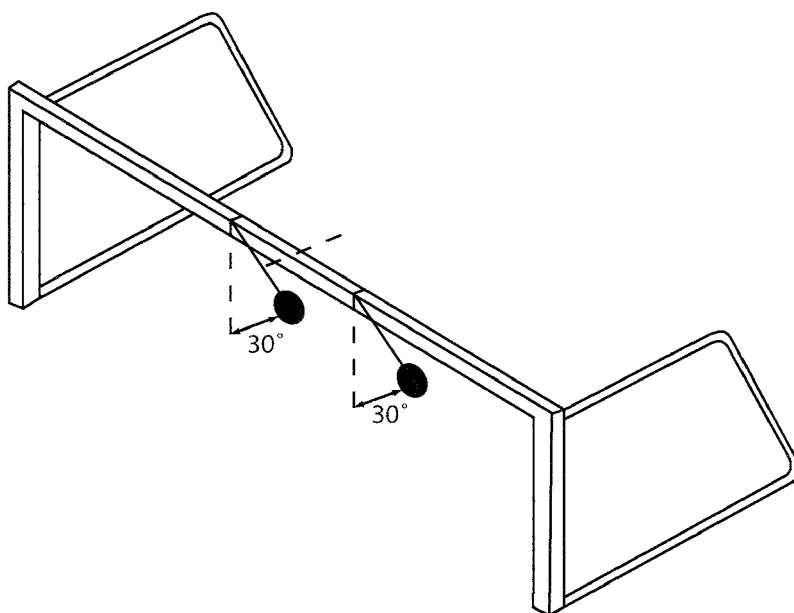

FIG. 2 Weights Simultaneously Displaced at a 30° Angle from the Vertical Position, Held for  $10 \pm 2$  s, Released, and Allowed to Swing Freely

5.6 Weights shall be simultaneously displaced at a 30° angle from the vertical position (perpendicular to the cross-bar) with rope extended, held for  $10 \pm 2$  s, released, and allowed to swing freely (Fig. 2).

5.7 The test shall be repeated with the weights swung from a 30° angle on the opposite side.

**6. Labels**

6.1 No product covered by this specification and produced after the approval date shall, by label, marking, or other means, indicate compliance unless it conforms to all requirements herein.

6.2 Soccer goals meeting this specification shall be labeled “Special Tilt-Resistant Goal Meeting ASTM F2673.”

**7. Keywords**

7.1 soccer goal; tilt-resistant goal

*ASTM International takes no position respecting the validity of any patent rights asserted in connection with any item mentioned in this standard. Users of this standard are expressly advised that determination of the validity of any such patent rights, and the risk of infringement of such rights, are entirely their own responsibility.*

*This standard is subject to revision at any time by the responsible technical committee and must be reviewed every five years and if not revised, either reapproved or withdrawn. Your comments are invited either for revision of this standard or for additional standards and should be addressed to ASTM International Headquarters. Your comments will receive careful consideration at a meeting of the responsible technical committee, which you may attend. If you feel that your comments have not received a fair hearing you should make your views known to the ASTM Committee on Standards, at the address shown below.*

*This standard is copyrighted by ASTM International, 100 Barr Harbor Drive, PO Box C700, West Conshohocken, PA 19428-2959, United States. Individual reprints (single or multiple copies) of this standard may be obtained by contacting ASTM at the above address or at 610-832-9585 (phone), 610-832-9555 (fax), or [service@astm.org](mailto:service@astm.org) (e-mail); or through the ASTM website ([www.astm.org](http://www.astm.org)). Permission rights to photocopy the standard may also be secured from the ASTM website ([www.astm.org/COPYRIGHT/](http://www.astm.org/COPYRIGHT/)).*